

get started

INSTANT POT® **DUO CUISINE**
USER MANUAL

Instant™

Welcome

to your new Instant™ Duo Cuisine!

This Instant Pot® Duo Cuisine can help you cook healthy, delicious meals more easily and in less time. We hope you fall in love with Instant Pot® cooking, and enjoy it in your kitchen for years to come!

Get started with your new Duo Cuisine!



Scan to Get Started!

To make your cooking experience with Instant™ as easy as possible, we have created 4 simple steps with how-to videos to guide you. Scan the QR code and follow the steps to become an Instant™ Chef in no time!

instantbrands.com.au/pages/getting-started



Download the **Instant Brands® Connect app** to access 1000's of recipe ideas.



Visit the **Instant Brands ANZ YouTube channel** for how-to videos and recipe inspiration.

⚠️ WARNING

Before using your new Duo Cuisine, read all instructions, including the Safety and Warranty document. Failure to follow the safeguards and instructions may result in personal injury and/or property damage.

CONTENTS

Important safeguards	2
What's in the box	7
Using your Duo Cuisine	9
Using the lid	12
Initial set up	15
Pressure Cook	19
Slow Cook	21
Steam	22
Sauté	23
Yogurt	25
Keep Warm	26
Cleaning	27
Learn More	28
Warranty	29



IMPORTANT SAFEGUARDS



⚠️ WARNING

Safety Instructions

At Instant™, we want you to feel comfortable using our products. This Instant Pot® Duo Cuisine was designed with you and your safety in mind.

Read all instructions before using and only use this appliance as directed. Failure to follow these Important Safeguards may result in personal injury and/or property damage and will void your warranty.

When using electrical appliances, basic safety precautions should always be followed to reduce the risk of fire, electric shock, personal injury and/or property damage.

Placement

- **DO** place the appliance on a countertop only. Always operate the appliance on a stable, non-combustible, level surface.
- **DO** make sure all parts are dry and free of food debris before placing the cooking pot on the cooker base.
- **DO NOT** place the appliance on or close to a hot gas or electric burner, or a heated oven.
- **DO NOT** use the appliance near water or flame.
- **DO NOT** use outdoors. Keep out of direct sunlight.
- **DO NOT** place on anything that may block the vents on the bottom of the appliance.

General Use

The removable inner cooking pot is extremely hot during use, and can be extremely heavy when full of ingredients.

- **DO** use oven mitts when handling the inner cooking pot and removing accessories.
- **DO** place hot accessories on a heat-resistant surface or cooking plate.
- **DO** use care when lifting the cooking pot from the cooker base to avoid burn injury.
- **DO** use extreme caution when the cooking pot contains hot food, hot oil or other hot liquids.

⚠ WARNING

- **DO** use only the Instant Pot® lid that came with this cooker base. Using any other pressure cooker lids may cause personal injury and/or property damage.
- **DO NOT** use the appliance without the removable inner cooking pot installed.
- **DO NOT** touch the metal portion of the lid, the appliance's hot surfaces, or any accessories during or immediately after cooking because they will be hot. Only use the side handles for carrying or moving.
- **DO NOT** use this appliance for deep frying or pressure frying with oil.
- **DO NOT** move the appliance while it is in use and use extreme caution when disposing of hot grease.
- **DO NOT** allow children or persons with reduced physical, sensory or mental capabilities to operate this appliance. Close supervision is necessary when any appliance is used by or near children and persons with reduced physical, sensory or mental capabilities. Children should not play with this appliance.
- **DO NOT** use the appliance for anything other than household use. It is not intended for commercial use.
- **DO NOT** leave the appliance unattended while in use.

Pressure Cooking

This appliance cooks under pressure. Allow the appliance to depressurise naturally or release all excess pressure before opening. Inappropriate use may result in burns, personal injury and/or property damage.

- **DO** make sure the appliance is properly closed before operating.
- **DO** check that the steam release valve is installed.
- **DO** use the Instant Pot® lid when pressure cooking. For instructions on how to use the lid, see the *User Manual* or *Getting Started Guide*.
- **DO** turn the appliance off if steam escapes from the steam release valve and/or float valve in a steady stream for longer than 3 minutes. If steam escapes from the sides of the lid, turn the appliance off and make sure the sealing ring is properly installed.
- **DO** check the steam release valve, steam release pipe, anti-block shield and float valve for clogging before use.
- **DO NOT** remove the pressure cooking lid with unprotected hands.

⚠ WARNING

- **DO NOT** attempt to force the lid off the Instant Pot® cooker base.
- **DO NOT** move the appliance when it is under pressure.
- **DO NOT** cover or obstruct the steam release valve and/or float valve with cloth or other objects.
- **DO NOT** attempt to open the appliance until it has depressurised, and all internal pressure has been released. Attempting to open the appliance while it is still pressurised may lead to sudden release of hot contents and may cause burns, personal injuries and/or property damage.
- **DO NOT** place your face, hands or exposed skin over the steam release valve or float valve when the appliance is in operation or has residual pressure, and do not lean over the appliance when removing the lid.

Overfill During Pressure Cooking

Overfilling may cause a risk of clogging the steam release pipe and developing excess pressure.

- **DO NOT** fill the inner cooking pot over the line labelled 'PC MAX – 2/3'.
- **DO NOT** fill the inner cooking pot over the line labelled 'PC MAX – 1/2' when cooking foods that expand during cooking such as rice, dried beans or dried vegetables.
- **DO** be aware that certain foods, such as applesauce, cranberries, pearl barley, oatmeal or other cereals, split peas, noodles, macaroni, rhubarb, or spaghetti can foam, froth, sputter, and clog the pressure release device (steam vent).
- **DO NOT** fill the cooking pot higher than the "PC MAX – 1/2" line when cooking these foods.
- **DO NOT** place oversized foods into the inner cooking pot as they may cause risk of fire, personal injury, and property damage.
- **DO** check that the sealing ring is properly installed.

Accessories

- **DO** use only accessories or attachments authorised by Instant Brands. The use of parts, accessories or attachments not recommended by the manufacturer may cause a risk of personal injury, property damage, fire, or electric shock.

⚠ WARNING

- **DO** use only an authorised stainless-steel Instant Pot® inner cooking pot to reduce the risk of pressure leakage.
- **DO** only replace the sealing ring with an authorised Instant Pot® sealing ring to prevent personal injury, property damage and damage to the appliance.
- **DO NOT** use the included accessories in a microwave, toaster oven, convection or conventional oven, or on a ceramic cooktop, electric coil, gas range or outdoor grill.

Care and Storage

- **DO** let the appliance cool to room temperature before cleaning or storage.
- **DO NOT** store any materials, other than the multicooker cooking pot, in the cooker base when not in use.
- **DO NOT** place any combustible materials in the cooker base, such as paper, cardboard, plastic, Styrofoam or wood.

Power Cord

A short power-supply cord is used to reduce the risk resulting from it being grabbed by children, becoming entangled in, or tripping over a longer cord.

WARNING: Spilled food can cause serious burns. Keep appliance and cord away from children. Never drape cord over edge of counter, never use outlet below counter, and never use with an extension cord.

- **DO NOT** let the power cord touch hot surfaces or open flame, including the stovetop.
- **DO NOT** use with power converters or adapters, timer switches or separate remote-control systems.

This appliance has a 3-prong earthed plug. To reduce the risk of electric shock:

- **ONLY** plug the power cord into an earthed electrical outlet.
- **DO NOT** remove earth.

If the unit includes a detachable power cord:

To connect, always attach the power cord to the appliance first, then plug the power cord into the wall outlet.

⚠ WARNING

Electrical Warning

The cooker base contains electrical components that are an electrical shock hazard. Failure to follow these instructions may result in electric shock.

To protect against electrical shock:

To disconnect, select Cancel, then remove plug from power source. Always unplug when not in use, as well as before adding or removing parts or accessories, and before cleaning. To unplug, grasp the plug and pull from the outlet. Never pull from the power cord.

- **DO** regularly inspect the appliance and power cord. **DO NOT** operate the appliance if the power cord or plug is damaged, or after the appliance malfunctions or is dropped or damaged in any manner. For assistance, contact Customer Care by email at support.au@instantbrands.com
- **DO NOT** attempt to repair, replace or modify components of the appliance, as this may cause electric shock, fire, personal injury, and/or property damage and will void the warranty.
- **DO NOT** tamper with any of the safety mechanisms, as this may result in personal injury or property damage.
- **DO NOT** put liquid or food of any kind into cooker base without the inner cooking pot.
- **DO NOT** immerse power cord, plug or the appliance in water or other liquid.
- **DO NOT** use the appliance in electrical systems other than 220-240 V ~, 50-60 Hz for Australia and New Zealand.

**SAVE THESE
INSTRUCTIONS**

WHAT'S IN THE BOX

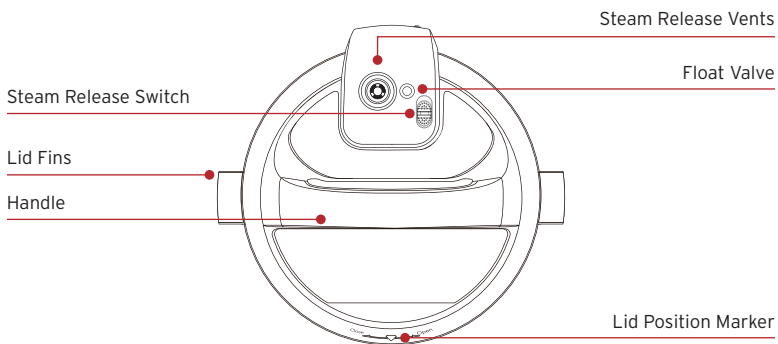

Bottom of Lid

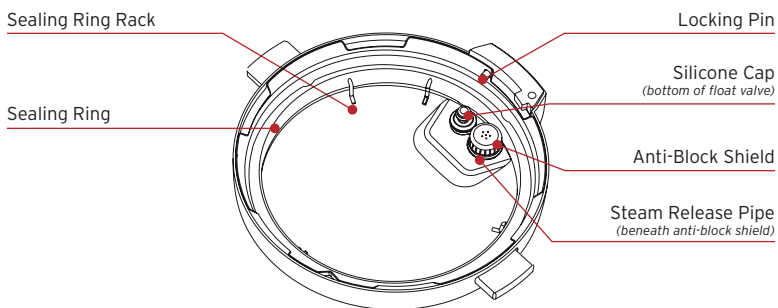

Inner Pot

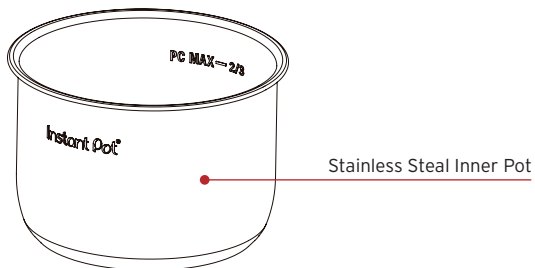

Cooker Base

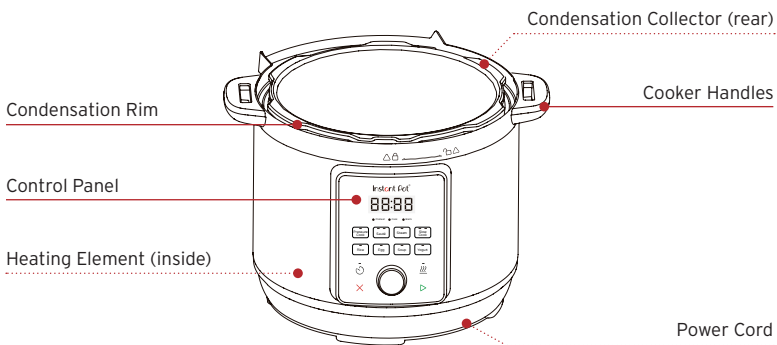

Parts + Accessories

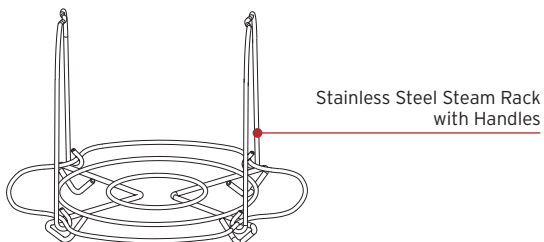

Illustrations are for reference only and may differ from the actual product.

USING YOUR DUO CUISINE

Control Panel

We've designed the control panel to be simple to use and easy to read.

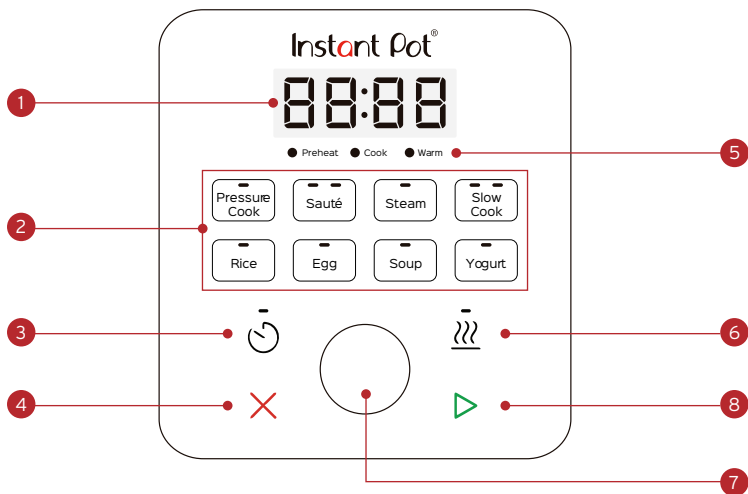

1. Time Display
2. Smart Programs
 - Pressure Cook
 - Sauté
 - Steam
 - Slow Cook
 - Rice
 - Egg
 - Soup
 - Yogurt
3. Delay Start
4. Cancel
5. Status Indicators
6. Keep Warm
7. Control Dial
8. Start

Control Panel Functions

Cancel

Press Cancel to stop a Program at any time. The device returns to functional selection mode.

Delay Start

Postpone cooking up to 24 hours. Select a Program and if desired, adjust the cooking time, then press Delay Start to turn the setting on. Use the dial to adjust the number of hours before cooking will begin. The device makes 3 beeps to confirm the changes.

Adjust Cooking Time on the fly

To change the time during the cooking process, select the program you are using, adjust the time using the dial and press Start to resume cooking.







Keep Warm Setting

Turns on by default for all smart programs except Sauté, Steam and Yogurt. You may turn off Keep Warm setting by pressing the Keep Warm Button.

Memory Function setting

Every program comes with a memory function for every change made to the time. Press and hold Cancel for more than 3 seconds to reset all the functions to their default settings.

Control Panel Status

	PLUG IN MODE All screen elements and LED lights will turn on for 1 second.
	SCREEN OFF If there is no activity for over 2 minutes, it will return to the power saving mode, and the dim light is OFF.
	END Once cooking is completed, it will display End.
 <p>1 2</p>	LOCK THE LID When you select a pressure cook function and the lid is on but not locked the display will alternately show Lid and Err to prompt you to lock the lid.
 <p>1 2</p>	UNLOCK AND OPEN LID When you select the saute function and the lid is on but not locked the display will alternately show OPEN and Lid to prompt you to take off the lid.
	PREHEATING The display will show On until it is in cooking mode.

USING THE LID

You'll use the pressure cooking lid for most cooking programs, and especially for pressure cooking. Always use the pressure cooking lid that came with this Instant Pot® Duo Cuisine base.

How to close and lock the lid

For pressure cooking, the lid must be securely locked into place to prevent steam from escaping. When you place the lid on the cooker base:

1. Line up the line on the lid with the arrow at the side of the control panel. 

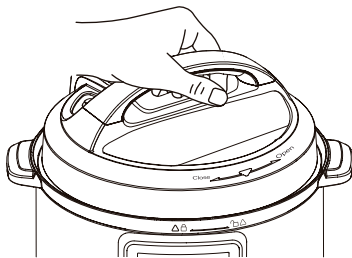

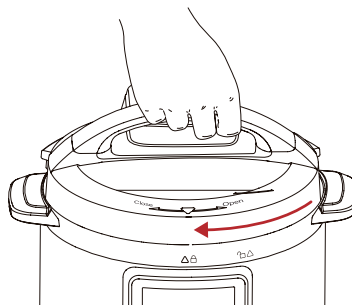

2. Turn the lid clockwise until the line on the lid lines up with the line on the control panel. 



The display will alternately show Lid and Err when the lid has been put on the pot but not in the lock position. This screen will not show up when the lid has been entirely removed or locked properly.

How to unlock and open the lid

Once steam is completely released, you must unlock the lid before opening it:

1. Line up the line on the lid with the arrow at the side of the control panel.  

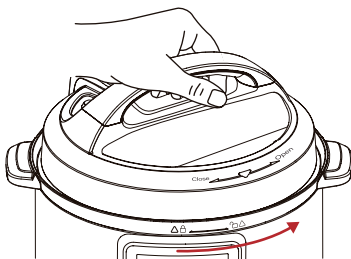

How to release steam

Instant Pot® Duo Cuisine can release steam naturally or quickly. Use the one that best fits the type of food you're cooking.

Natural steam release

1. Ensure that the switch is in sealing position for steam to be naturally released.

Quick steam release

Turn the switch to venting position for quick steam release.

1. After cooking, move the switch to the venting position and wait for all pressure to release.

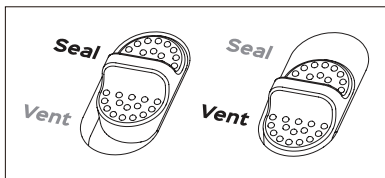

The float valve is a visual indication of whether there is pressure in the cooker (pressurised) or not (depressurised). It appears in 2 positions:

Pressurised

The float valve has visibly popped up above the surface of the lid.

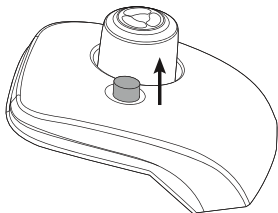

Depressurised

The float valve has descended, and the top is flush with the lid.

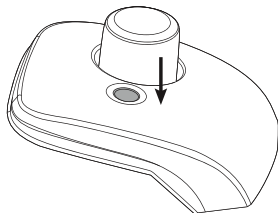

⚠ DANGER

DO NOT attempt to remove the lid while the float valve is up and NEVER attempt to force the lid open. Contents are under extreme pressure. Float valve must be down before attempting to remove the lid. Failure to follow these instructions may result in serious personal injury and/or property damage.

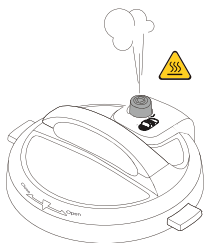

⚠ Pressure Cooking Caution

This appliance uses pressure to cook. Allow the appliance to release all excess pressure and steam before opening the lid. Opening the lid before pressure is released may result in burns, injury and/or property damage. Read more in the Important Safeguards section of this manual.

INITIAL SET UP

Clean before use

1. Wash the inner cooking pot with hot water and soap. Rinse and use a soft cloth to dry the outside. Or you can wash the inner cooking pot in the dishwasher.
2. Wipe the heating element inside the cooker base with a soft cloth to ensure there are no stray packaging particles.

Setting up the condensation collector

The condensation collector sits at the back of the cooker base and accumulates overflow moisture from the condensation rim. It should be installed before cooking, then emptied and rinsed out after each use.

Remove the condensation collector

- Pull the condensation collector away from the cooker base; do not pull down.

Note: the tabs on the cooker base and the grooves on the condensation collector.

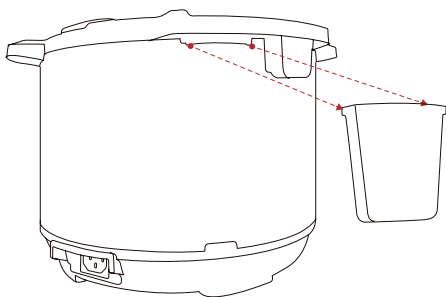

Using the Sealing Ring

When the lid is closed, the sealing ring installed on the underside of the lid creates an air-tight seal between the lid and the cooker base.

- The sealing ring must be installed before using the cooker and should be cleaned after each use.

Note: the tabs on the cooker base and the grooves on the condensation collector.

- Sealing rings stretch over time with normal use. To keep your product safe, replace the sealing ring every 12 to 18 months. Replace sooner if you notice stretching, deformation, or damage.

Install the Sealing Ring

1. Place the sealing ring over the sealing ring rack and press it into place. Press down firmly to ensure there is no puckering.
2. The sealing ring should be snug and should not fall out when the lid is turned over.

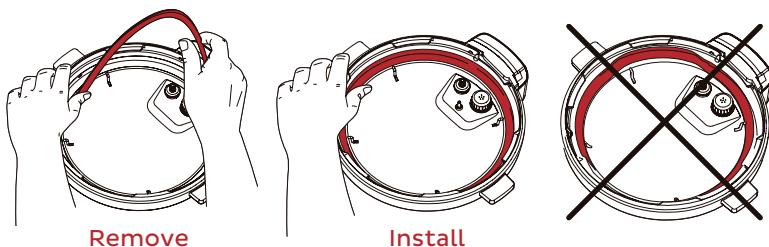

Remove the Sealing Ring

1. Grip the edge of the sealing ring and pull it out from behind the sealing ring rack.
2. Inspect the rack to ensure it is secured, centered, and an even height all the way around the lid. If the sealing ring rack is deformed, do not try to repair it.

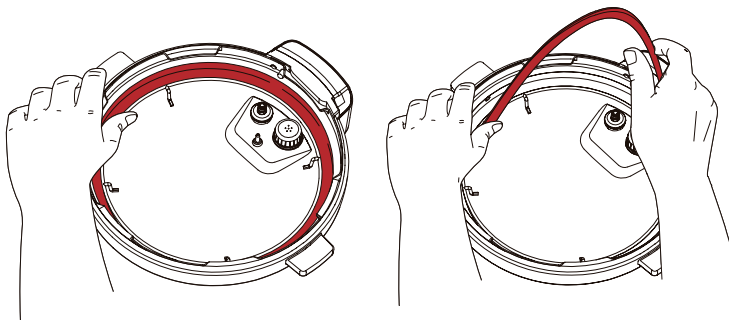

Plug in cord

- When you're ready to use your Instant Pot® Duo Cuisine, plug the electrical cord into the power socket on the back of the unit.

Test run

- Setting up your new Instant Pot® Duo Cuisine for a test run is a great way to familiarise yourself with how the unit works before you actually cook a meal.

To perform a test run:

1. Add minimum water of 375mL to the inner cooking pot and place inner cooking pot into the cooking base.
2. Place the lid on top of the cooker base and lock the lid.
Refer to page 12 How to close and lock the lid.
3. Select Pressure Cook on the control panel.
4. Press Start to begin.
5. During preheating, the screen displays On.
6. Once the unit enter cooking mode the time will appear on the display and start to count down.
7. Press Keep Warm to turn off the Keep Warm setting.
8. When cooking is done, DO NOT OPEN LID IMMEDIATELY.
9. The float valve will descend, once it is depressurised, then it is safe to open lid.
Refer to page 13 How to unlock and open the lid.
10. Release steam by moving to the venting position.
11. Unlock and open the lid.
12. Discard any remaining water, and then wash and dry the inner cooking pot.

Now you're ready to cook a meal in your Instant Pot® Duo Cuisine!

PRESSURE COOK

To get pressure cooking, follow the same basic steps as you did in the initial test run (water test) – but add food and water this time!

Pressure cooking uses pressurised steam to cook foods quickly and evenly. The pressure cook functions are Pressure Cook, Rice, Egg and Soup.

Other settings

- Automatic Keep Warm is set to ON by default for all Pressure Cook programs.
- Delay Start is available for all Pressure Cook programs.

How to pressure cook

Prep

Cut, chop, season or marinate your ingredients according to your recipe.

Preheat

1. Place the inner cooking pot into the cooker base.
2. Add ingredients to the inner cooking pot.
3. Place the lid on top of the inner cooking pot and be sure it is locked.
4. Select a pressure cooking function on the control panel.
5. Turn the dial to adjust the cooking time.
6. The Keep Warm function is on by default. Press Keep Warm to turn it off.
7. Press start to begin.
8. The unit will start to build pressure and the display shows On.

Cook

9. When the unit enters cooking mode, the display will show the time and start to count down.
10. When the timer reaches 00:00, cooking will stop.
11. If Keep Warm has been activated the Keep Warm setting will automatically turn on once cooking is completed. Press Cancel if you want to turn Keep Warm off.

If you want to delay cooking, press Delay Start and select delay time before start cooking.

Release steam

Choose the steam release method that works for your recipe.

See *'How to release steam'* on page 13 for full details.

Using liquid to create steam

Pressure cooking requires liquid in the inner cooking pot to produce the steam needed. Unless your recipe specifies otherwise, you will need a minimum of 375ml of liquid for pressure cooking.

Pressure cooking liquids should be water-based, such as stock, soup or juice. If using canned, condensed, or cream-based soup, add water as directed above.

SLOW COOK

Slow cooking lets you make your favourite simmering and stewing recipes. This program does not use pressure to cook food.

Other settings

- The Keep Warm setting is on by default for the Slow Cook program.
- Delay Start is available for the Slow Cook program.
- The unit does not preheat during Slow Cook. It will rise to the optimum temperature and maintain this temperature during slow cooking.

How to slow cook

Prep

Cut, chop, season or marinate your ingredients according to your recipe.

Cook

1. Place the inner cooking pot into the cooker base.
2. Add ingredients to the inner cooking pot.
3. Place the lid on top of the inner cooking pot and be sure it is locked.
4. Select the Slow Cook function on the control panel.
5. Press the Slow Cook function to select Lo or Hi temperature.
6. Turn the dial to adjust the cooking time.
7. The Keep Warm function is on by default. Press Keep Warm to turn it off.
8. Press start to begin.
9. The unit will enter cooking mode, the display will show the time and start to count down.

Complete

1. The display shows End when the cooking time finishes.
2. If Keep Warm has been activated it will turn on automatically once cooking is completed. Press the Cancel button to turn Keep Warm off.

If you want to delay cooking, press Delay Start and select delay time before you start cooking.

STEAM

The Steam program cooks food using steam but no pressure; it's especially useful for vegetables like broccoli, zucchini, carrots, and others. You can adjust the settings according to your recipe.

Other settings

- The Keep Warm function is not available.
- Preheating time is subjected to the amount of volume in the inner cooking pot.

How to steam

Prep

Cut or chop the ingredients according to your recipe.

Preheat

1. Fill inner cooking pot with 2.5-5 centimetres of water, and place a steamer basket in the cooking pot. Do not fill water above the steamer basket.
2. Once done, place ingredients onto a plate or bowl and put on top of the steamer basket.
3. Place the lid on top of the cooker base and lock the lid.
4. Select the Steam function on the control panel.
5. Turn the dial to adjust the cooking time.
6. Press start to begin.

Cook

7. When the unit enters cooking mode, the display will show the time and start to count down.
8. When the cooking time finishes the display will show End.

SAUTÉ

Use Sauté in place of using a frypan or saucepan. Sautéing can deepen the flavours of your food, or can simmer, thicken or reduce sauces.

Other settings

- The Keep Warm function is not available.
- Delay Start is not available.
- Preheating time is subject to the amount of volume in the inner cooking pot.

How to sauté

Prep

Cut, chop, season or marinate your ingredients according to your recipe.

Preheat

1. Place the empty inner pot into the cooker base. Do not close the lid.
2. Select Saute function on the control panel.
3. Press Saute function to select Lo or Hi temperature.
4. Turn the dial to adjust the cooking time.
5. Press Start to begin.
6. The display will show on.

Cook

7. Add ingredients but do not close the lid. You may add oil into the inner pot as it promotes even cooking of your food and prevents sticking.
8. Once the unit reaches the set temperature the display will show Hot for 3 seconds.
9. The display will then show the time and start counting down.

Complete

10. Once the cooking is completed the display will show End.

Sautéing before Pressure or Slow Cooking

Quite often, you'll want to sauté foods to brown them before further cooking them.

1. Sauté ingredients.
2. Press Cancel.
You can deglaze the inner cooking pot now before switching to Pressure Cook or Slow Cook (see Deglazing below).
3. Select the Smart Program you want to use to finish cooking.

Deglazing

Deglazing is the process of adding a liquid to a hot pan, releasing all of the delicious, caramelised pieces stuck to the bottom..

1. Remove food from inner pot.
2. Add water, stock or wine.
3. Use wooden spoon or silicone spatula to loosen food stuck to bottom of the inner cooking pot.

YOGURT

You can use your Instant Pot® Duo Cuisine to easily make delicious, fermented dairy and non-dairy yogurt.

Other settings

- The Keep Warm function is not available.
- Delay Start is not available.

How to make yogurt

Prep

Only use pasteurised milk to make yogurt in the Duo Cuisine.

Preheat

1. Add pasteurised milk to the inner cooking pot and place the inner cooking pot into the cooker base.
2. Add a starter culture to the milk according to package instructions. *If using plain yogurt as a starter, ensure that it contains an active culture. Mix in 30 mL of yogurt per 3.7 L of milk or follow a trusted recipe.*
3. Place the lid on top of the cooker base and lock the lid.
4. Select the Yogurt function on the control panel.
5. Use the dial to change the cooking time.
6. Press Start to begin.
7. During preheat the display will show on.

Cook

8. When the unit reaches the correct temperature the display will show Hot for 3 seconds.
9. The unit will then enter cooking mode and the timer will start to count down.

Complete

10. Once the cooking time has ended the display will show End.
11. Allow yogurt to cool.
12. Place in the fridge for 12-24 hours to develop flavours.

How much to make?

The minimum volume of milk that can be made in the Duo Cuisine is 1 litre. The maximum volume of milk that you can make is 3.8L.

KEEP WARM

You can choose to have Keep Warm turn on automatically after cooking on the Pressure Cook, Slow Cook, Rice, Egg and Soup functions.

Keep warm after cooking

1. When cooking is finished, automatic warming begins. The timer shows the time passed, up to 10 hours.
2. To turn automatic warming off, press Cancel and the light above the button turns off.

CLEANING

Clean your Instant Pot® Duo Cuisine after each use. Always unplug the unit and let all parts cool to room temperature before cleaning. Before use or storing, make sure all surfaces are dry.

Part	Cleaning instructions
Lid and Parts • Anti-Block Shield • Sealing Ring • Steam Release Vent • Silicone Cap • Steam Release Cover	<ul style="list-style-type: none">• Hand wash with hot water and mild dish soap or wash in dishwasher, top rack.• Remove all small parts from lid before washing.• With steam release valve and anti-block shield removed, clean interior of steam release pipe to prevent clogging.• To drain water from the lid after dishwashing, grasp the lid handle and hold the lid vertically over a sink, then turn it all the way around.• After cleaning, store the lid upside down on the cooker base.• Store sealing rings in a well-ventilated area to disperse odor.• To eliminate odours from sealing ring, add 250 mL water and 250 mL white vinegar to inner cooking pot, and run Pressure Cook for 5-10 minutes, then use Quick Steam Release.
Inner Cooking Pot	<ul style="list-style-type: none">• Wash after each use.• Hand wash with hot water and mild dish soap or wash in dishwasher*• Hard water stains may need a vinegar-dampened sponge and scrubbing to remove.• For tough or burned food residue, soak in hot water for a few hours before cleaning.• Dry all exterior surfaces before placing in cooker base.
Power cord	<ul style="list-style-type: none">• Use a barely-damp cloth to wipe any particles off cord.
Cooker base	<ul style="list-style-type: none">• Wipe the inside of the cooker base as well as the condensation rim with a barely-damp cloth, and allow to air dry.• Clean the outside of the cooker base and the control panel with a soft, barely-damp cloth or sponge.

**Some discoloration may occur after machine washing, but this will not affect the cooker's safety or performance.*

TROUBLESHOOTING

Register your Instant Pot® Duo Cuisine today at <https://instantbrands.com.au/pages/product-registration>.

Get in touch with Customer Care by email at support.au@instantbrands.com or by phone at 1800 251 643 or +61 2 9317 1000.

Problem	Possible reason	Try this
Occasional clicking or light cracking sound.	The sound of power switching and expanding pressure board when changing temperatures.	This is normal; no action needed.
	Bottom of the inner pot is wet.	Wipe exterior surfaces of the inner pot. Make sure the heating element is dry before inserting the inner pot back into the multi-cooker base.
Difficulty closing the lid.	Sealing ring is not properly installed.	Reposition the sealing ring. Make sure it is snug behind the sealing ring rack.
	Float valve is in the popped-up position.	Gently press the float valve downward with a long utensil.
	Contents in multi-cooker are still hot.	Hold the quick release switch in the Vent position as you lower the lid onto the multi-cooker base slowly, allowing heat to dissipate.
Difficulty opening the lid.	⚠ DANGER Contents may be under pressure. To avoid scalding injury, DO NOT attempt to force the lid open.	
	Pressure inside the multi-cooker.	Release pressure according to recipe. Only open the lid after the float valve has dropped down.
	Float valve stuck in the popped-up position due to food debris or residue.	Release pressure completely, then tap the float valve gently with a long utensil. Open the lid cautiously, then thoroughly clean the float valve, surrounding area, and lid before next use.
The inner pot is stuck to the lid when the multi-cooker is opened.	Cooling of the inner pot may create suction, causing the inner pot to adhere to the lid.	To release the vacuum, move the quick release switch to the Vent position.

TROUBLESHOOTING

Problem	Possible reason	Try this
Steam leaks from side of lid.	No sealing ring in the lid.	Install a sealing ring.
	The sealing ring is damaged or not installed properly.	Replace the sealing ring.
	Food debris attached to the sealing ring.	Remove the sealing ring and clean it thoroughly.
	The lid is not closed properly.	Open, then close the lid.
	The sealing ring rack is warped or off-centre.	Remove the sealing ring from the lid, then check the sealing ring rack for bends or warps. Contact Customer Care .
	The inner pot rim may be misshapen.	Check for deformation and contact Customer Care .
The float valve does not rise.	Food debris on the float valve or float valve silicone cap.	Remove the float valve from the lid and clean it thoroughly. Perform the Initial test run to check for function and record your findings. Contact Customer Care .
	Too little liquid in the inner pot.	Check for scorching on the bottom of the inner pot. Add thin, water-based liquid to the inner pot according to its size. 5.7L: 1 ½ cups (375 mL)
	Float valve's silicone cap is damaged or missing.	Install or replace the float valve and/or silicone cap.
	Float valve obstructed by lid-locking mechanism.	Tap the float valve with a long utensil. If the float valve does not drop, turn the multi-cooker off. Contact Customer Care .
	No heat in the inner pot.	Perform the Initial test run to check for function and record your findings. Contact Customer Care .
	Inner pot base may be damaged.	Perform the Initial test run to check for function and record your findings. Contact Customer Care .
Minor steam leaking or hissing from the steam release valve during the cook cycle.	Quick release switch is not in the Seal position.	Move the quick release switch to the Seal position.
	Multi-cooker is regulating excess pressure.	This is normal; no action required.
The display remains blank after connecting the power cord.	Bad power connection or no power.	Ensure power connection to base is tight . Check outlet to make sure it is powered. Inspect power cord for damage. If damage is noticed, contact Customer Care .
	Multi-cooker's electrical fuse has blown.	Contact Customer Care .

TROUBLESHOOTING

Problem	Possible reason		Try this
Steam gushes from the steam release valve when the quick release switch is in the Seal position.	Not enough liquid in the inner pot.		Add thin, water-based liquid to the inner pot according to its size. 5.7L: 1 ½ cups (375 mL)
	Pressure sensor control failure.		Contact Customer Care .
	Steam release valve is not seated properly.		Move the steam release switch to Vent then back to the Seal position.
Error code appears on the display and the multi-cooker beeps continuously.	C1 C2 C6 C6H C6L	Faulty sensor.	Contact Customer Care .
	C5	Temperature is too high because the inner pot is not placed in the multi-cooker base.	Press Cancel and wait for heating element to cool; make sure there are no foreign objects in multi-cooker base; insert or reposition inner pot in multi-cooker base and re-enter commands.
		Temperature is too high.	Check for scorching on bottom of inner pot. Add thin, water-based liquid to the inner pot according to its size. 5.7L: 1 ½ cups (375 mL)
	C7	Heat element has failed.	Contact Customer Care .
		Not enough liquid.	Add thin, water-based liquid to the inner pot according to its size. 5.7L: 1 ½ cups (375 mL)
		Quick release switch is in the Vent position.	Move the quick release switch to the Seal position.
	Lid	Lid is not in the correct position for the selected program.	Open and close the lid.
			Do not use a lid when using Sauté.
Error code appears on the display and the cooker beeps continuously.	Food burn	High temperature detected at bottom of inner pot; the multi-cooker automatically reduces the temperature to avoid overheating.	Starch deposits at the bottom of the inner pot may have blocked heat dissipation. Turn the multi-cooker off, release pressure according to the recipe, and inspect the bottom of the inner pot.
	PrSE	Pressure has accumulated during a non-pressure cooking program.	Move the quick release switch to the Vent position.

Any other servicing must be performed by an authorised representative.

LEARN MORE

There's a whole world of Instant Pot® information and help just waiting for you. Here are some of the most helpful resources.

Register your product

instantbrands.com.au/pages/product-registration

Contact Consumer Care

instantbrands.com.au

support.au@instantbrands.com

1800 251 643 or +61 2 9317 1000

Download the Instant Brands Connect App

- Recipes
- New User Tips
- Getting Started Videos



Join the community

  @Instant.anz

  @Instantanz

Product specifications

Model	Volume	Wattage	Power	Weight	Dimensions
DUPC61-BK	5.7 Litres	1000 W	220-240V~, 50-60Hz	5.2 kg	cm: 31.0 L x 34.0 W x 33.0 H

WARRANTY

Limited Warranty

This Limited Warranty is issued by Instant Brands (Australia) Pty Ltd (Instant Brands Australia) and is effective for one year from the date of original consumer purchase. Proof of original purchase date and return of your appliance is required to obtain service under this Limited. Return of your appliance to us will be done in accordance with our instructions only. Provided that this appliance is operated and maintained in accordance with written operating instructions attached to or furnished with the appliance or published operating instructions on www.instantbrands.com.au, Instant Brands Australia will, in its sole and exclusive discretion, either: (i) repair defects in materials or workmanship; or (ii) replace the appliance. In the event that your appliance is replaced, the Limited Warranty on the replacement appliance will expire 12 months from the date of original consumer purchase.

We remind you the appliance you purchased is for personal use only (not commercial use).

Any modification/alteration or attempted modification/alteration to your appliance will void this Limited Warranty, unless such modification/alteration or attempted modification/alteration was expressly authorised by an Instant Brands Australia Representative in writing.

This Limited Warranty only covers Instant Brands Australia's appliances/products and is not extended to any other appliances, products, equipment, components, or devices that you use or may use in conjunction with the Instant Brands Australia's appliances.

To claim under this Limited Warranty:

1. Contact Instant Brands Australia at:
Sydney Corporate Park
Level 1, 182-184 Bourke Road, Alexandria, NSW 2015
Email: support.au@instantbrands.com
2. Provide a description of the appliance you believe has malfunctioned due to defective parts or workmanship.
3. If it is necessary for the appliance to be sent to Instant Brands Australia for repair or replacement, Instant Brands Australia will send you a pre-paid shipping label and you must send the appliance and your dated sales receipt to Instant Brands Australia along with the appliance. If you do not have your dated sales receipt, please advise Instant Brands Australia in advance, and Instant Brands Australia will attempt to verify your purchase.
4. If Instant Brands Australia determines that the appliance has malfunctioned due to defective parts or workmanship, and is covered under this Limited Warranty, Instant Brands Australia will repair and return the appliance, or send you a replacement appliance, at Instant Brands Australia's cost.
5. Any repaired or replaced appliance will be covered by this Limited Warranty for the remainder of the original warranty period or ninety (90) days following your receipt of the replacement or repaired appliance, whichever is greater.
6. If Instant Brands Australia confirms the appliance has not malfunctioned due to defective parts or workmanship, and/or is in working order, or if proof of purchase is not verified, Instant Brands Australia reserves the right to return the appliance to you at your pre-paid cost. If this cost is not met, Instant Brands Australia reserves the right to dispose of the appliance after 45 days' notice to you.

WARRANTY

Limitation and Exclusions

To the maximum extent permitted by law, the maximum liability of Instant Brands Australia, if any, for any allegedly defective appliance or part shall in no circumstances exceed the purchase price of a comparable replacement appliance or part of the same age.

This Limited Warranty does not cover:

1. Damage resulting from accident, modification/alteration (unless expressly authorised by an Instant Brands Australia Representative in writing), misuse, abuse, neglect, unreasonable use, use contrary to the written operating instructions attached to or furnished with the appliance or published operating instructions on instantbrands.com.au, normal wear and tear, commercial use, improper assembly by you or anyone, disassembly by you or anyone, repair by you or anyone, failure to provide reasonable and necessary maintenance, force majeure event including but not limited to fire, flood, acts of God;
2. Repairs where your appliance is used for other than normal, personal use or when it is used in a manner that is contrary to the written operating instructions attached to or furnished with the appliance or published operating instructions on instantbrands.com.au; or
3. Use of unauthorised parts and accessories, or repairs to parts and systems resulting from unauthorised repairs or modifications/alterations made to your appliance.

The cost of repair or replacement under these excluded circumstances shall be borne by you. Our goods come with guarantees that cannot be excluded under the Australian Consumer Law. You are entitled to a replacement or refund for a major failure and compensation for any other reasonably foreseeable loss or damage. You are also entitled to have the goods repaired or replaced if the goods fail to be of acceptable quality and the failure does not amount to a major failure.

Distributed by Instant Brands (Australia) Pty Ltd.
Sydney Corporate Park
Level 1, 182-184 Bourke Road, Alexandria, NSW 2015.
1800 251 643 or +61 2 9317 1000.
Email: support.au@instantbrands.com

©2024 Instant Brands (Australia) Pty Ltd.

Sydney Corporate Park
Level 1, 182-184 Bourke Road, Alexandria
NSW 2015, Australia.

instantbrands.com.au

© 2024 Instant Brands LLC.

INSTANT and INSTANT BRANDS are registered
trademarks of Instant Brands Holdings Inc.