

WARNING
HARDWARE THREAD GALLING

We provide Fasteners in Stainless Steel to ensure a long life span. Although Stainless Steel has many benefits like extreme corrosion resistance, threads can be sensitive to Nylon Lock Nuts. We recommend installing hardware with an Anti-Seize thread lubricant to prevent thread galling. Slowing down speed of install and keeping bolts stationary while tightening nuts are common practices to prevent thread galling.

INSTALLATION GUIDE:
VW MK7.5 GTI - FRONT SPLITTER (STREET EDITION)

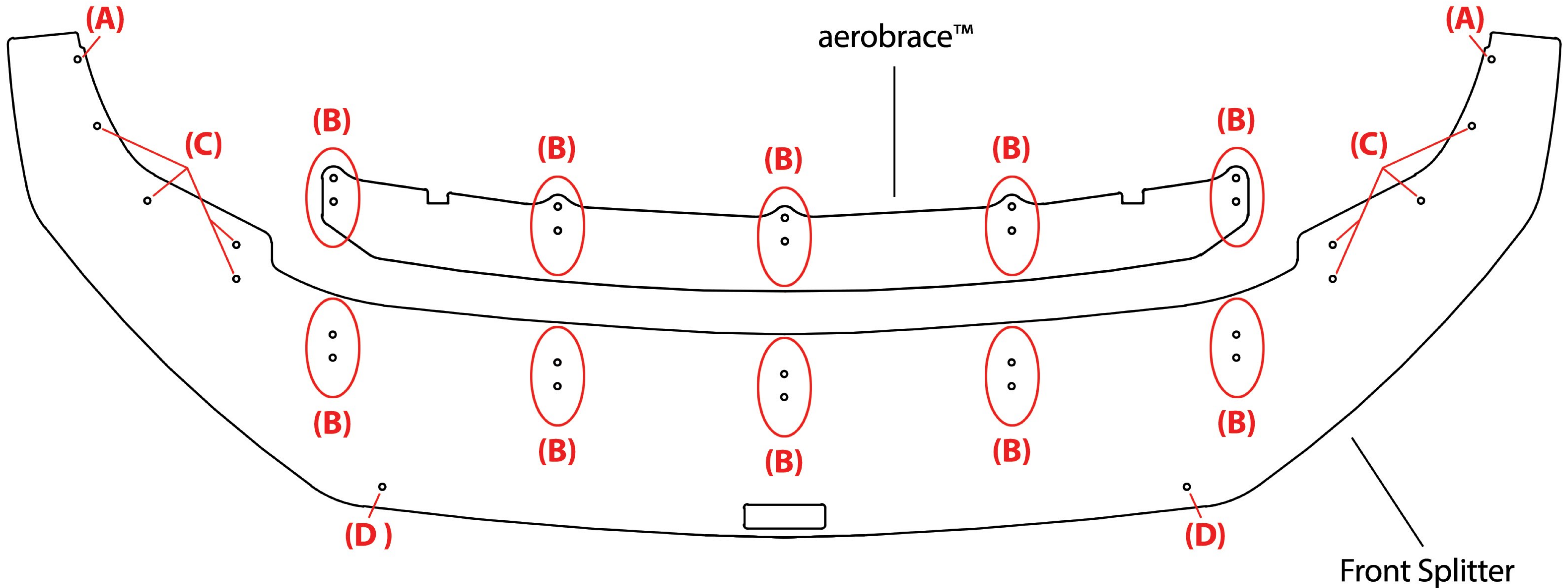

NOTES:
1. IGNORE SUPPORT ROD HOLES (D) IF YOU PURCHASED A V2.
2. Labeled Hardware corresponds to labeled holes shown in diagram.

**INSTALLATION GUIDE:
VW MK7.5 GTI - FRONT SPLITTER (STREET EDITION)**

ALIGNMENT HARDWARE (A)

QTY	DESCRIPTION
2	FACTORY TORX SCREWS

HARDWARE (C)

QTY	DESCRIPTION
8	M6 X 30MM BOLT
16	FENDER WASHER
8	M6 NYLON LOCKNUT

HARDWARE (B)

QTY	DESCRIPTION
10	M6 X 50MM BOLT
30	FENDER WASHER
10	3/4" OD X 1/2" LG SPACER
10	3/4" OD X 3/8" LG SPACER
10	M6 NYLON LOCKNUT

aerofabb, LLC is not responsible for damage to you or your vehicle while following this Install Guide and/or installing aerofabb products. Professional install is recommended. aerofabb also recommends installing hardware with **Anti-Seize (thread lubricant)** and Hand Tools to prevent thread galling.

NOTES:

1. CONFIRM NO HARDWARE IS MISSING BEFORE INSTALL.

MAKE THE FOLLOWING TOOLS READY FOR USE

- Drill
- 1/4" Drill Bit
- 10mm Wrench
- 4mm Hex Wrench
- T-25 Torx
- Anti-Seize (recommended)

1. Using a **T-25 Torx**, remove Front Bumper and place upside down on a non-abrasive surface.
2. Identify and remove the two Factory **T-25 Torx** screws **(A)** on underside of Front Bumper (closest to wheels).
3. Place the aerofabb Front Splitter on underside of Bumper. Reinstall Factory Torx Screws **(A)** passing through both Splitter and Factory Bumper holes **(A)**. Tighten Hardware.
4. With **ALIGNMENT HARDWARE (A)** installed and Splitter secured on both ends, drill through the 18 remaining Splitter holes **(B)** and **(C)**.
5. Pull only the following fasteners/spacers from **HARDWARE (B)** and set aside the remaining for later use in Step 9.
 - (QTY. 10) M6 X 50MM BOLT
 - (QTY. 10) FENDER WASHER
 - (QTY. 10) M6 NYLON LOCKNUT
 - (QTY. 10) 3/4"OD X 1/2"LG SPACER

INSTALLATION GUIDE: VW MK7.5 GTI - FRONT SPLITTER (STREET EDITION)

6. Using the fasteners/spacers pulled from **HARDWARE (B)** in step 5, install through Splitter holes **(B)**. Only tighten locknut by hand.

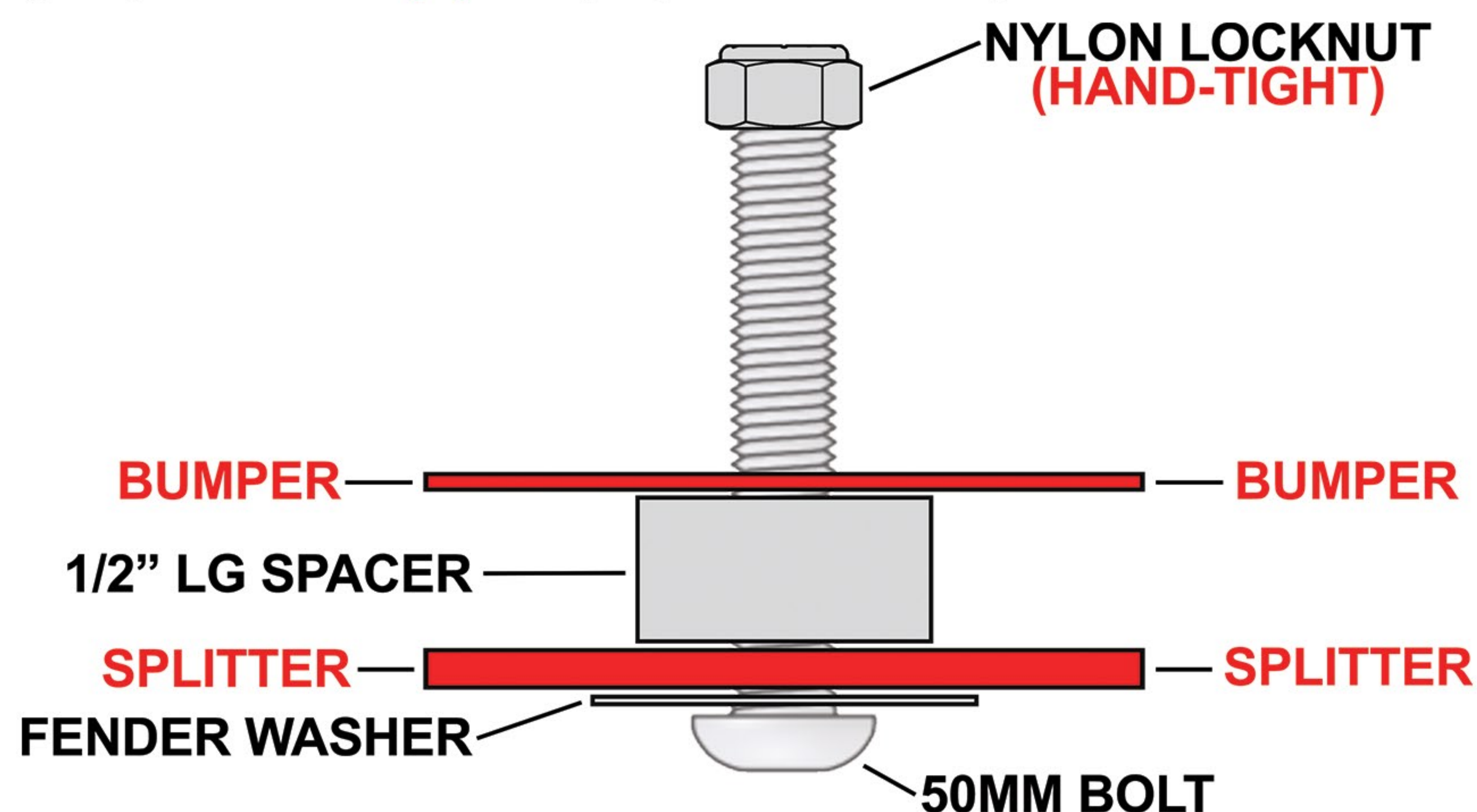

7. Install **HARDWARE (C)** through remaining Splitter holes **(C)** and tighten.

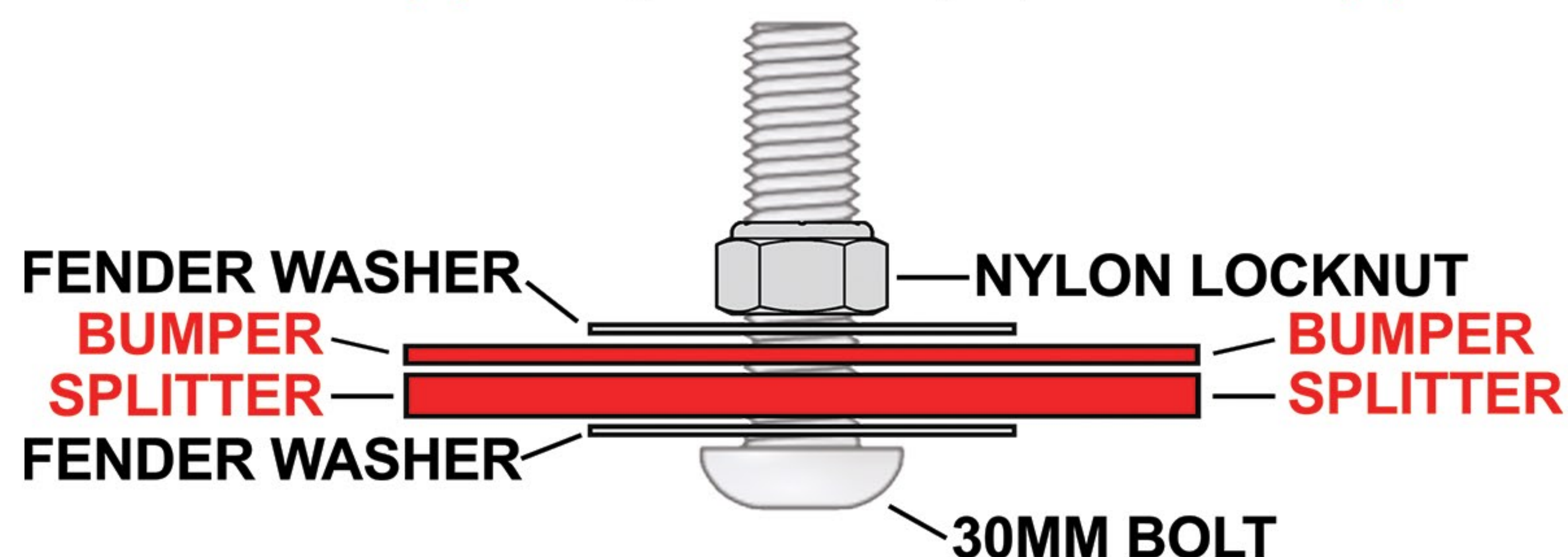

NOTES:

1. In Step 9 turn Bumper back upside down to tighten **HARDWARE (B)**.
- Desaturated Hardware in diagram indicates previously installed.
2. Check bolt threads for plastic debris before threading locknuts.
3. Do not overtighten Hardware..

8. Turn the Bumper right-side up and remove all locknuts from holes **(B)**.

9. Install the aerobraces™ with remaining fasteners from **HARDWARE (B)** and tighten.

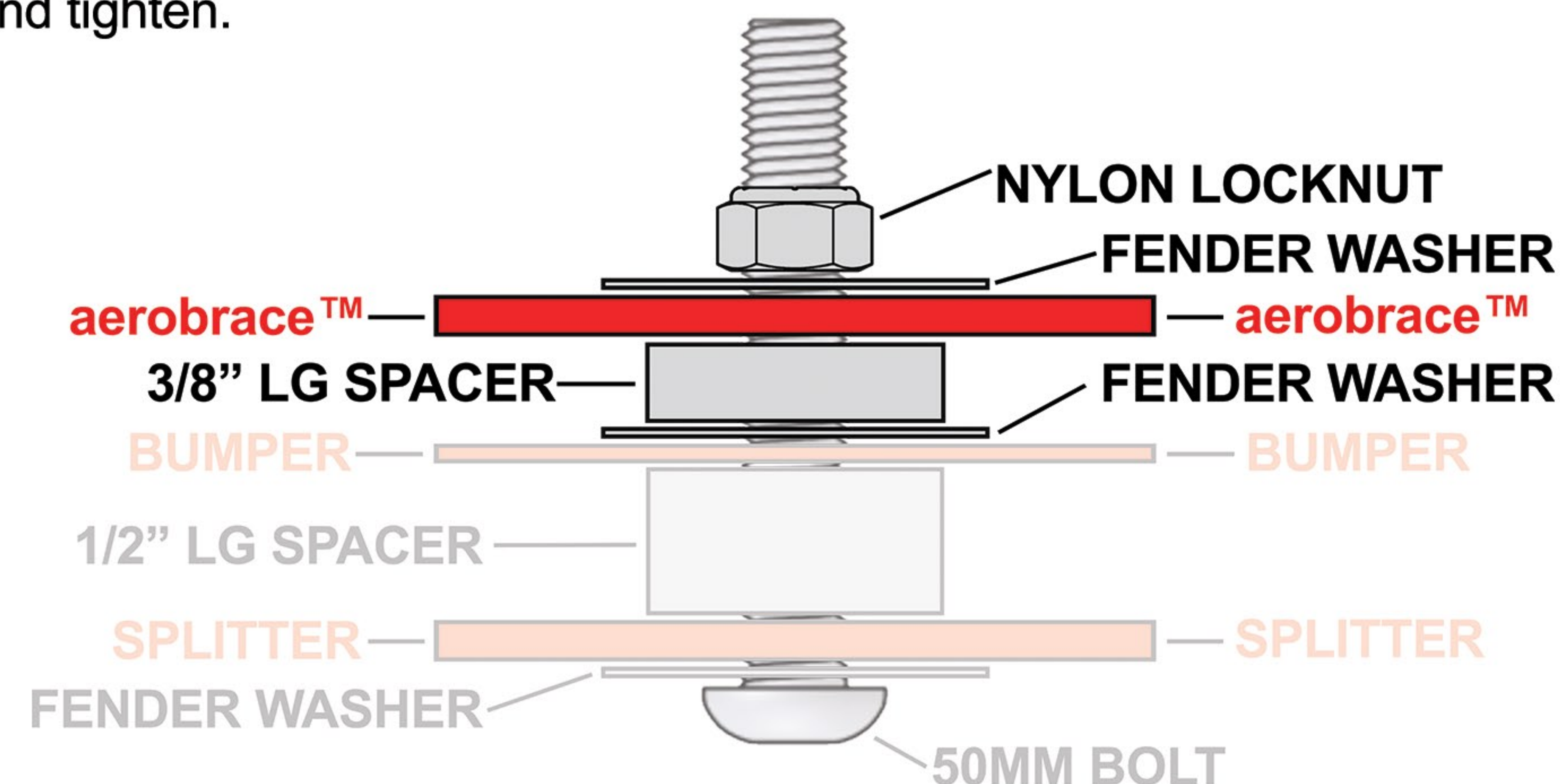

10. Inspect all Hardware for tightness to complete Front Splitter installation.

If you purchased a V1 Street Edition Front Splitter, please refer to the Support Rod Installation Guide to complete your installation.