

**WARNING**  
HARDWARE THREAD GALLING

We provide Fasteners in Stainless Steel to ensure a long life span. Although Stainless Steel has many benefits like extreme corrosion resistance, threads can be sensitive to Nylon Lock Nuts. We recommend installing hardware with an Anti-Seize thread lubricant to prevent thread galling. Slowing down speed of install and keeping bolts stationary while tightening nuts are common practices to prevent thread galling.

**INSTALLATION GUIDE:**  
VW MK7 GTI - FRONT SPLITTER (STREET EDITION)

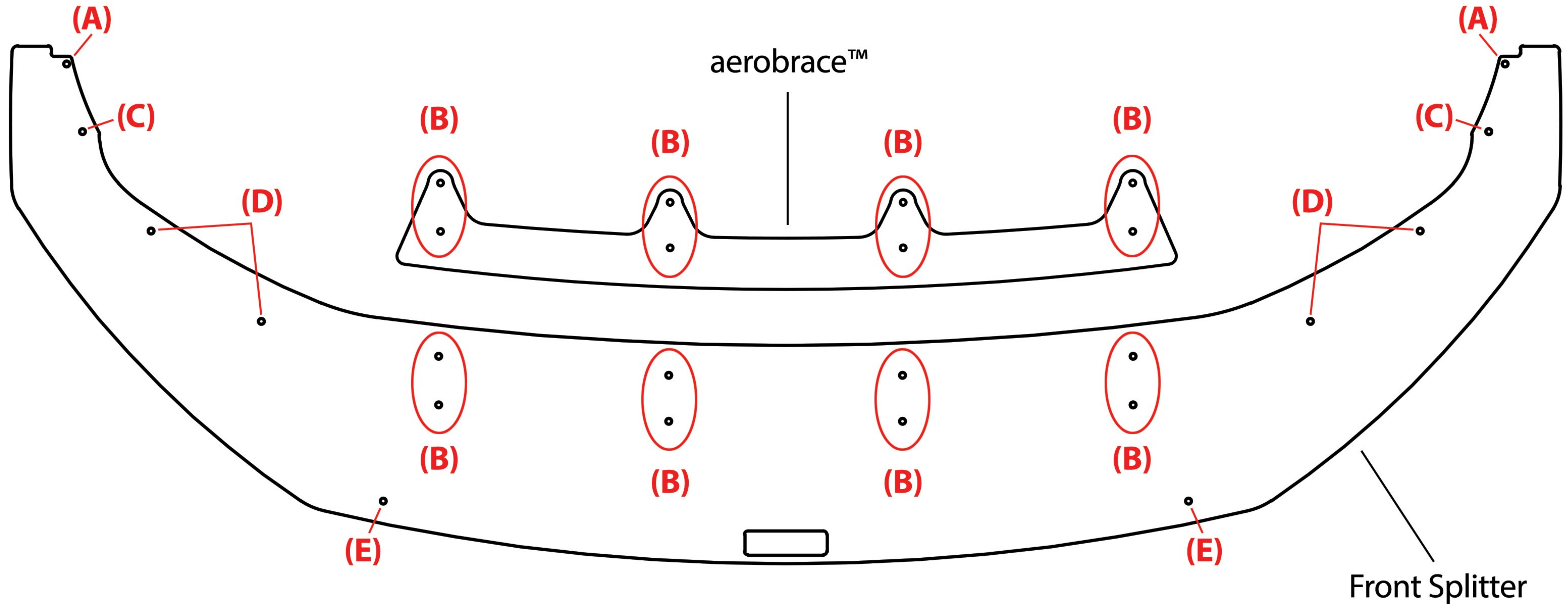

**NOTES:**

- 1. IGNORE SUPPORT ROD HOLES (E) IF YOU PURCHASED A V2.
- 2. Labeled Hardware corresponds to labeled holes shown in diagram.

**INSTALLATION GUIDE:  
 VW MK7 GTI - FRONT SPLITTER (STREET EDITION)**

**ALIGNMENT HARDWARE (A)**

| QTY | DESCRIPTION              |
|-----|--------------------------|
| 2   | M6 X 30MM BOLT           |
| 2   | M6 X 18MM OD WASHER      |
| 2   | 1/2" OD X 1/4" LG SPACER |
| 2   | M6 X 12MM OD WASHER      |
| 2   | M6 NYLON LOCKNUT         |

**HARDWARE (B)**

| QTY | DESCRIPTION              |
|-----|--------------------------|
| 8   | M6 X 50MM BOLT           |
| 24  | FENDER WASHER            |
| 8   | 1/2" OD X 1/4" LG SPACER |
| 8   | 3/4" OD X 5/8" LG SPACER |
| 8   | M6 NYLON LOCKNUT         |

**HARDWARE (C)**

| QTY | DESCRIPTION         |
|-----|---------------------|
| 2   | M6 X 30MM BOLT      |
| 2   | FENDER WASHER       |
| 2   | M6 X 18MM OD WASHER |
| 2   | M6 NYLON LOCKNUT    |

**HARDWARE (D)**

| QTY | DESCRIPTION      |
|-----|------------------|
| 4   | M6 X 30MM BOLT   |
| 8   | FENDER WASHER    |
| 4   | M6 NYLON LOCKNUT |

**NOTES:**

1. CONFIRM NO HARDWARE IS MISSING BEFORE INSTALL.

**MAKE THE FOLLOWING TOOLS READY FOR USE**

- Drill
- 1/4" Drill Bit
- 10mm Wrench
- 4mm Hex Wrench
- T-25 Torx
- Anti-Seize (recommended)

aerofabb, LLC is not responsible for damage to you or your vehicle while following this Install Guide and/or installing aerofabb products. Professional install is recommended. aerofabb also recommends installing hardware with **Anti-Seize (thread lubricant)** and Hand Tools to prevent thread galling.

1. Using a **T-25 Torx**, remove Front Bumper and place upside down on a non-abrasive surface.
2. Identify pre-existing holes **(A)** on underside of Front Bumper (closest to wheels).

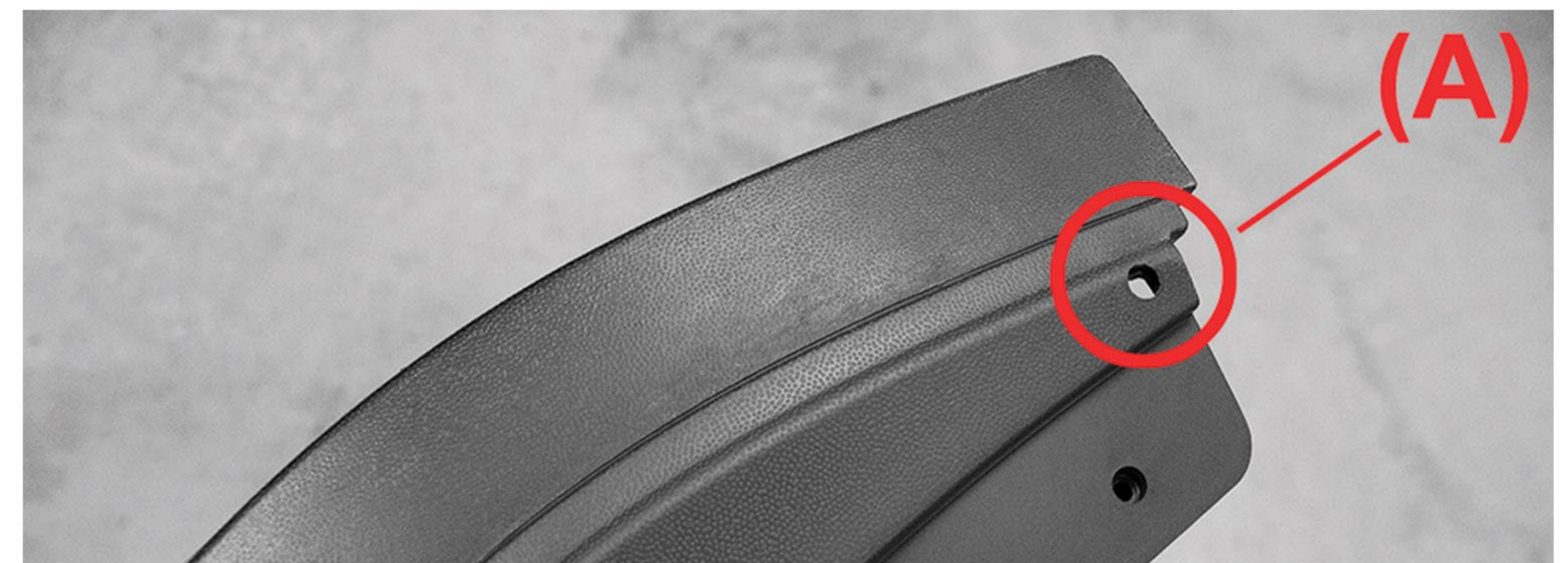

## INSTALLATION GUIDE: VW MK7 GTI - FRONT SPLITTER (STREET EDITION)

3. Using a 1/4" Drill Bit, drill directly through pre-existing Bumper holes (A) widening them to 1/4".

4. Place the aerofabb Front Splitter on underside of Bumper. Using a 4mm Hex and 10mm Wrench, install ALIGNMENT HARDWARE (A) passing through both Splitter and Bumper holes (A). Tighten Hardware.

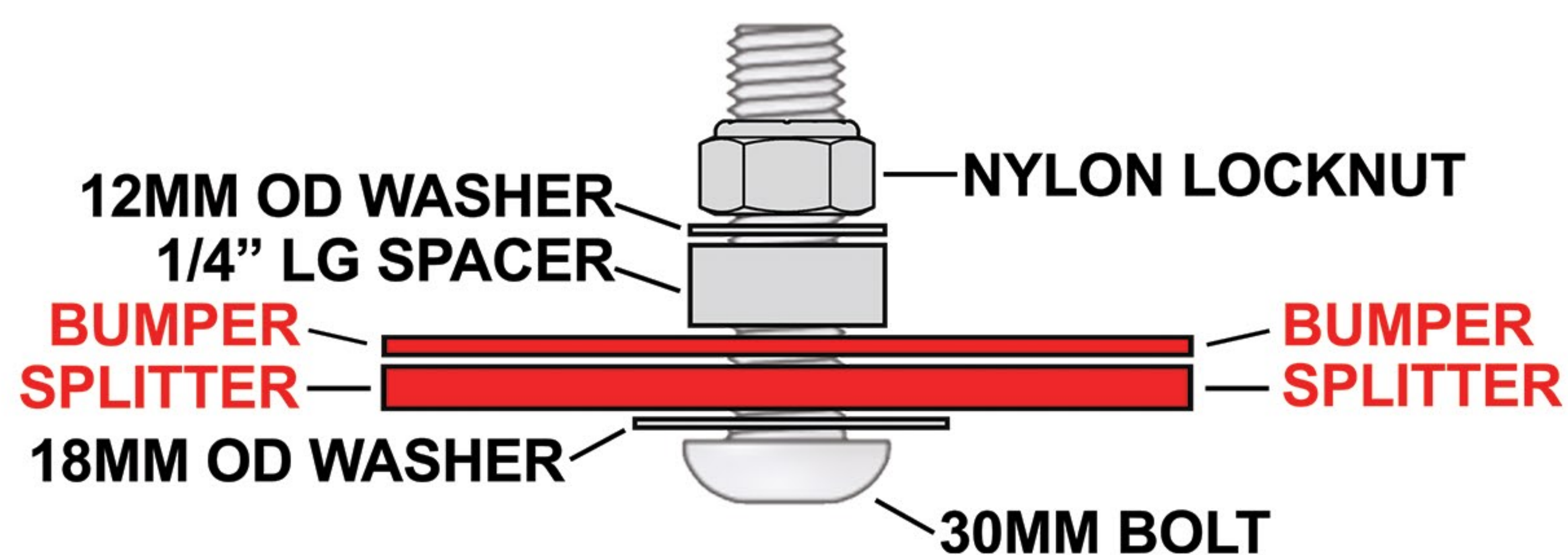

5. With ALIGNMENT HARDWARE (A) installed and Splitter secured on both ends, drill through the 14 remaining Splitter holes (B), (C), and (D).

### NOTES:

1. Run Bit through multiple passes to ensure holes are clear of debris.
2. Check bolt threads for plastic debris before threading locknuts.
3. Do not overtighten Hardware.

6. Pull only the following fasteners from HARDWARE (B) and set aside the remaining for later use in Step 11.

| QTY | DESCRIPTION              |
|-----|--------------------------|
| 8   | M6 X 50MM BOLT           |
| 8   | FENDER WASHER            |
| 8   | 3/4" OD X 5/8" LG SPACER |
| 8   | M6 NYLON LOCKNUT         |

7. Use above quantity to Install HARDWARE (B) through Splitter holes (B). Only tighten locknut by hand.

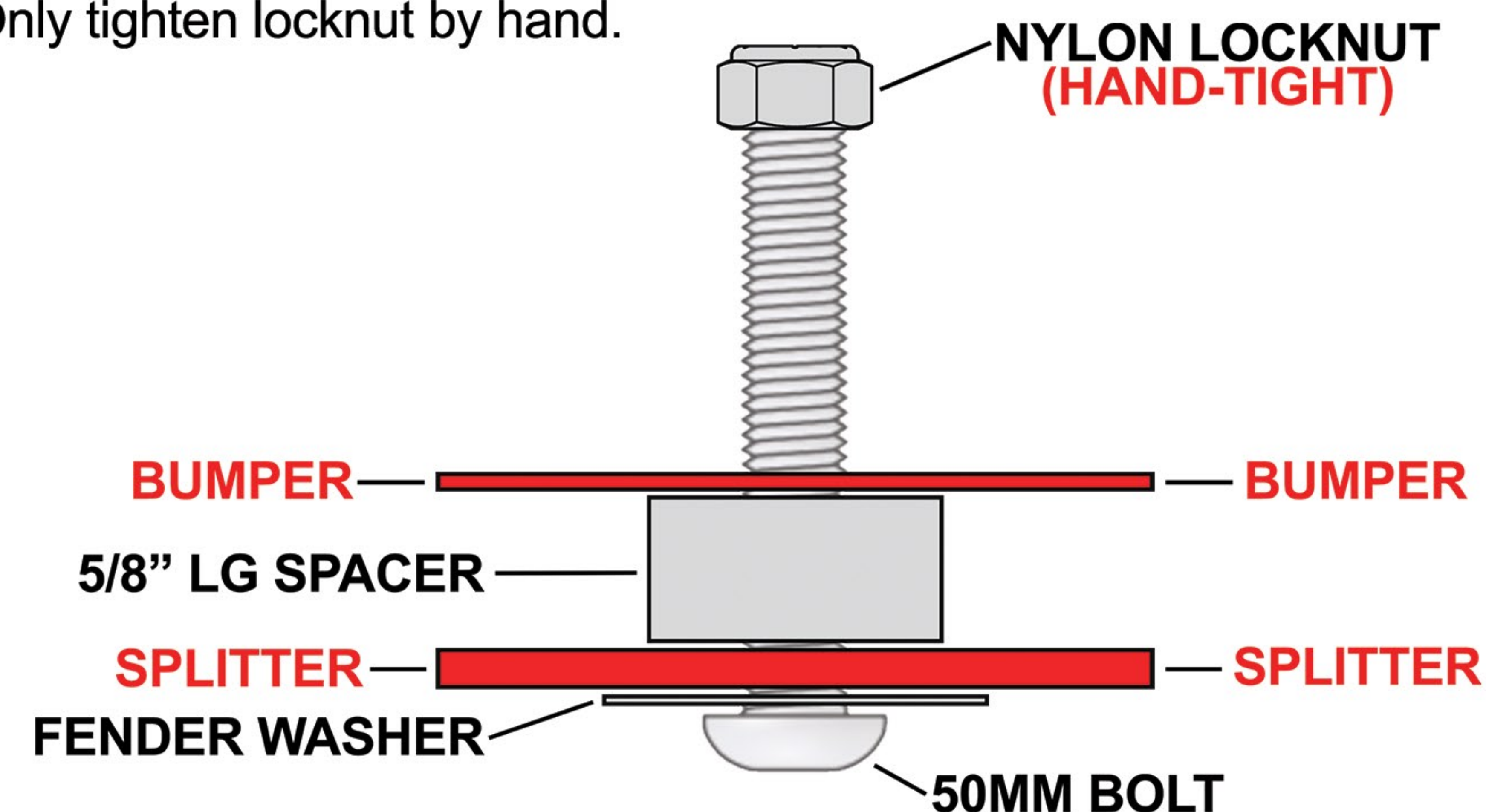

8. Install HARDWARE (C) through Splitter holes (C) and tighten.

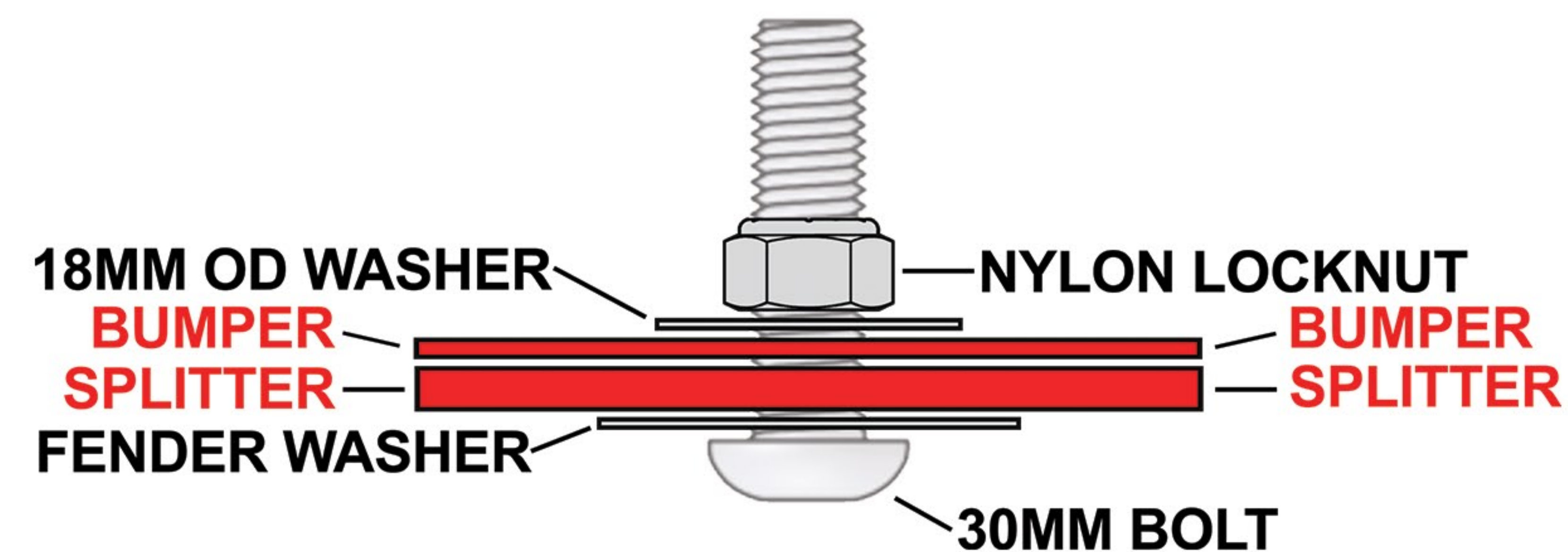

## INSTALLATION GUIDE: VW MK7 GTI - FRONT SPLITTER (STREET EDITION)

9. Install **HARDWARE (D)** through remaining Splitter holes **(D)** and tighten.

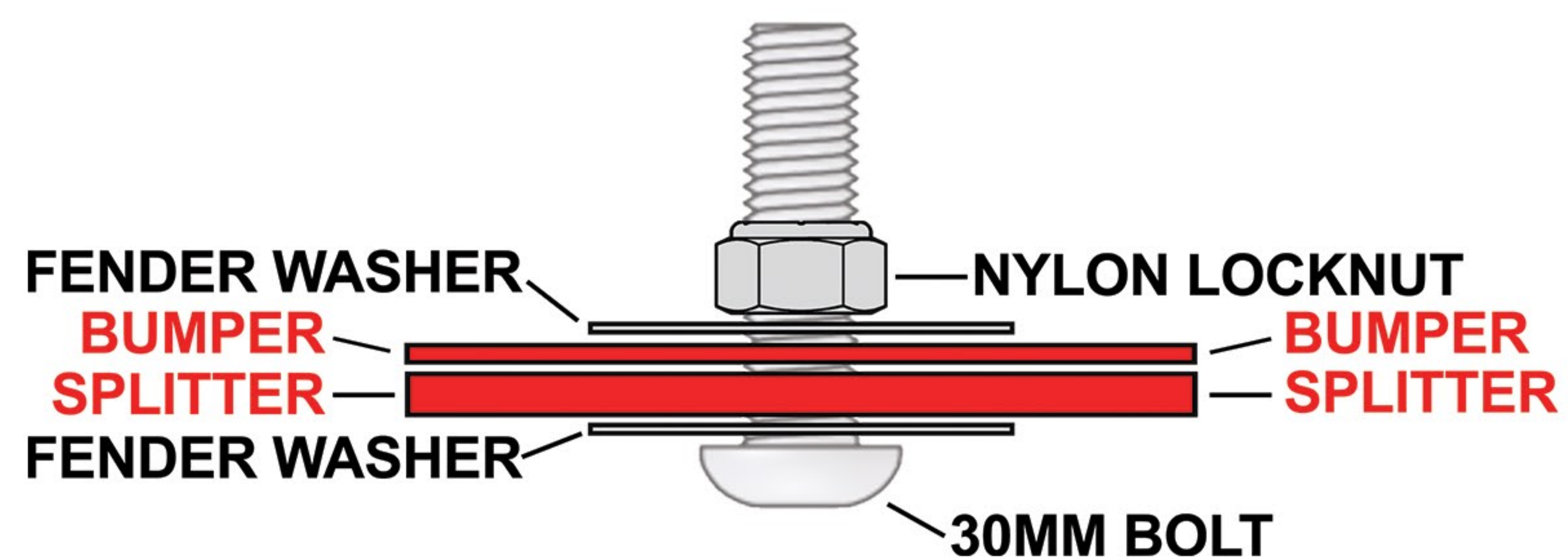

10. Turn the Bumper right-side up and remove all locknuts from holes **(B)**.

11. Install the aerobraces™ with remaining fasteners from **HARDWARE (B)** and tighten.

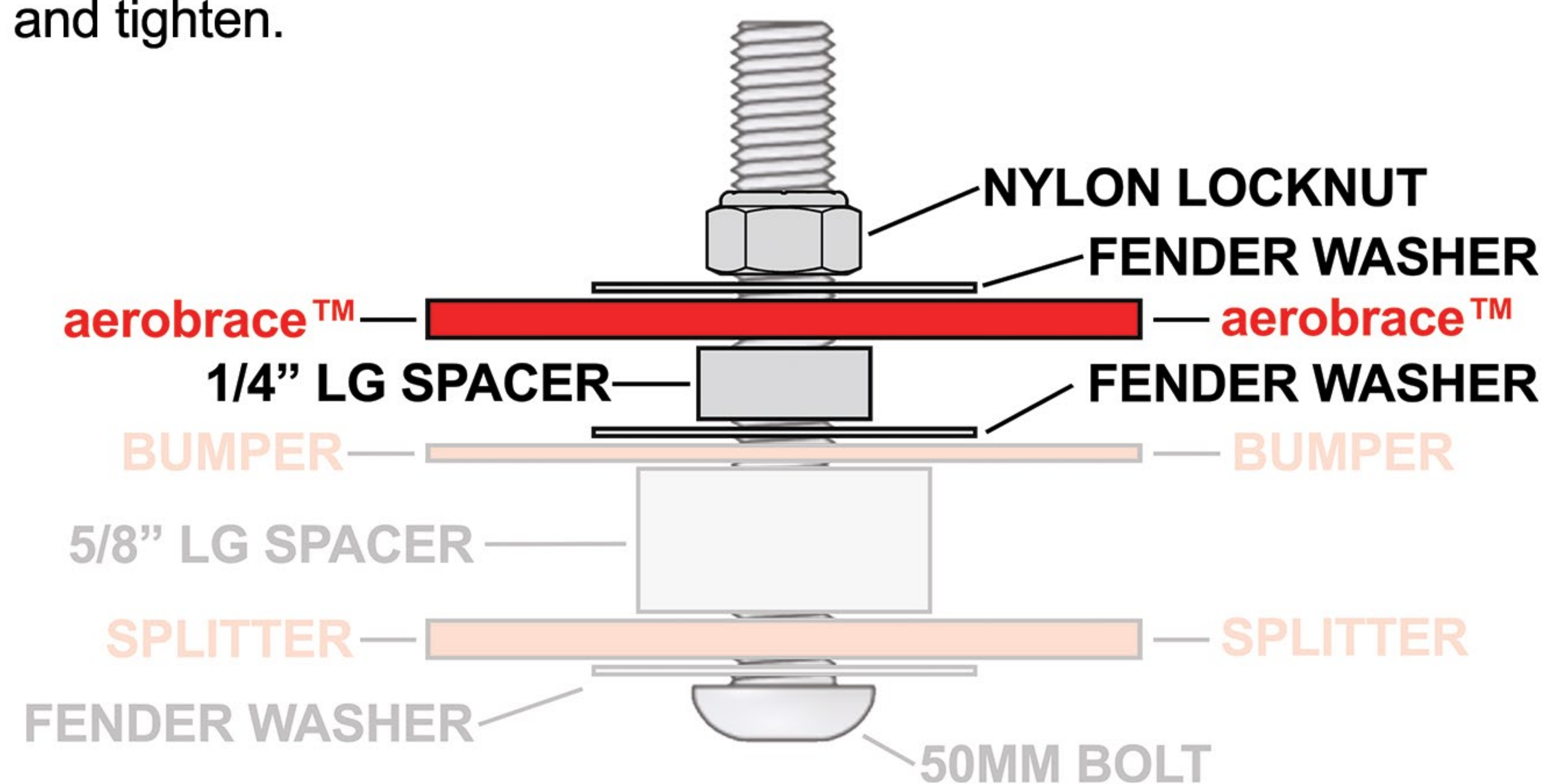

### NOTES:

1. In Step 11 turn Bumper back upside down to tighten **HARDWARE (B)**.  
- Desaturated Hardware in diagram indicates previously installed.
2. Check bolt threads for plastic debris before threading locknuts.
3. Do not overtighten Hardware.

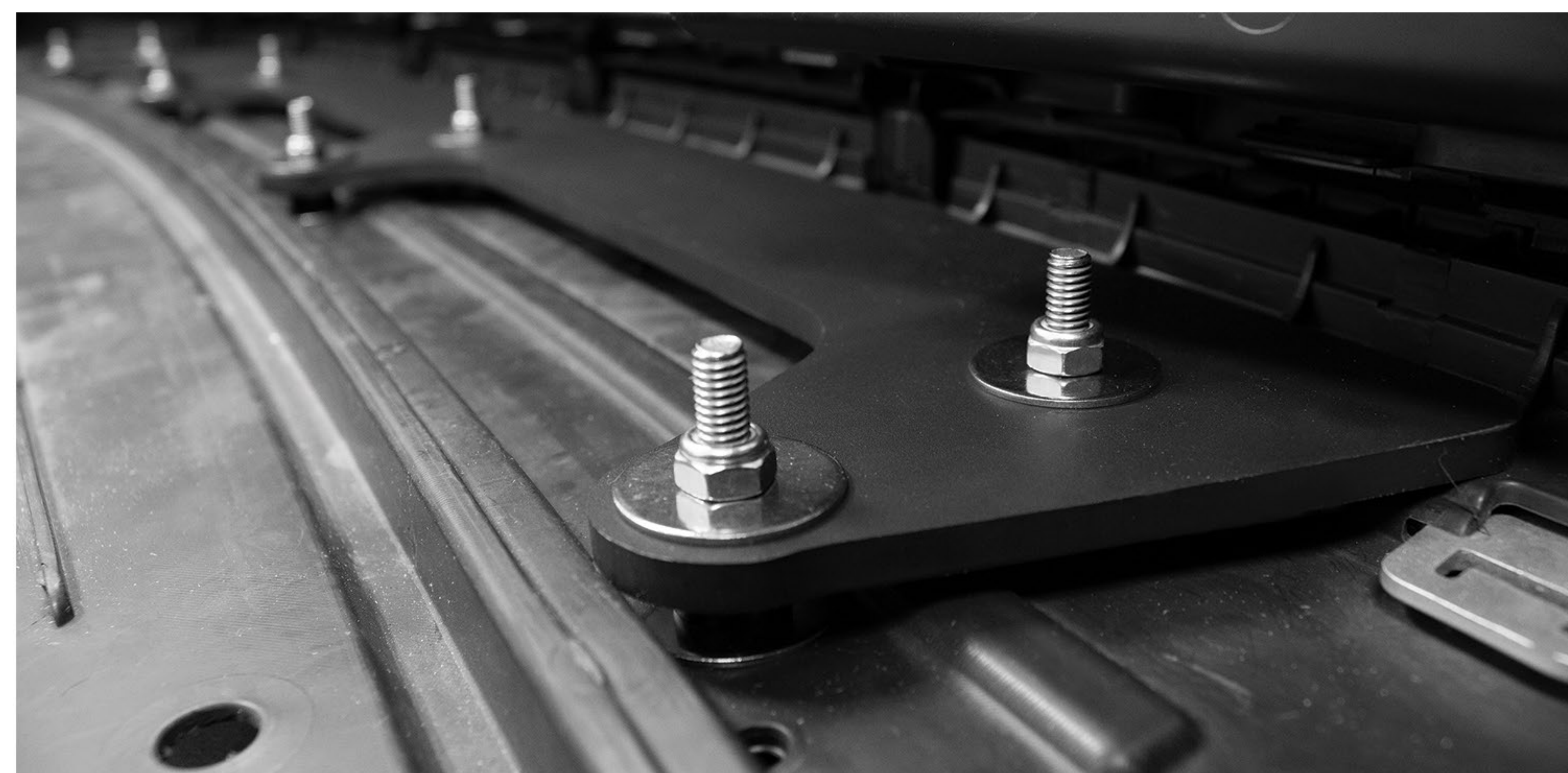

12. Inspect all Hardware for tightness to complete Front Splitter installation.

If you purchased a V1 Street Edition Front Splitter, please refer to the Support Rod Installation Guide to complete your installation.

## INSTALLATION GUIDE: VW MK7 GTI - SUPPORT RODS (V1 STREET EDITION)

### MAKE THE FOLLOWING TOOLS READY FOR USE

- Drill
- 7/32" Drill Bit
- 10mm Wrench
- Marking Tool
- 4mm Hex Wrench
- 3mm Hex Wrench
- Tape Measure
- Medium Thread Lock (recommended)
- T-25 Torx

aerofabb, LLC is not responsible for damage to you or your vehicle while following this Install Guide and/or installing aerofabb products. Professional install is recommended.

1. Measure 1" vertically from the bottom outer edge of factory canard #3 towards top of Bumper and mark.

2. Using a **7/32" Drill Bit**, drill straight through your marking. Repeat these steps on the opposite side.

3. Using the recommended **Thread Lock** and **3mm Hex**, attach Support Rods to Bumper with Hardware in the order as shown in diagram and tighten.

#### NOTES:

1. KEEP ROD HARDWARE LOOSE AND FOLLOW STEP BY STEP.
2. Run Bit through multiple passes to ensure holes are clear of debris.
3. As shown in Hardware diagram, only the Bumper side uses a M5 Washer (Used as spacer due to Bumper thickness).

4. Using a **T-25 Torx**, Reinstall Bumper on vehicle.

5. Evenly adjust Support Rod Length enough to reach Splitter holes **(E)** and attach with Hardware in the order as shown in diagram. Tighten with **Thread Lock**.

6. With Support Rods fastend to both Bumper and Splitter, adjust length untill there is no tension (Rods will have play in them up and down).

7. **LENGTHEN** Support Rods just until they begin to push down on Splitter. **-DO NOT shorten Rods (causing upwards tension)**

8. Using a **4mm Hex** and **10mm Wrench**, tighten all Rod Hinge Hardware.

9. Using a **10mm Wrench**, tighten Rod length adjustment Nuts.

**\*REFER TO PAGE 2 FOR DIAGRAM AND IMAGERY\***

**INSTALLATION GUIDE:**  
VW MK7 GTI - SUPPORT RODS (V1 STREET EDITION)

