



INSTALL GUIDE

VOLKSWAGEN GOLF MK7/MK7.5 GTI-R

COMPETITION SERIES THIRD BRAKE LIGHT

DISCLAIMER

aerofabb, LLC is not responsible for damage to you or your vehicle while following this Install Guide and/or installing aerofabb products. Professional install is recommended. aerofabb also encourages you to read through this Install Guide in its entirety before beginning the actual installation process.



HARDWARE

QTY	DESCRIPTION
2	M5 X 12MM BOLT (DOME HEAD BLK ALUMINUM)

TOOLS NEEDED

QTY	DESCRIPTION
1	3MM HEX WRENCH

ADDITIONAL TOOLS NEEDED (GEN 1 WING OWNERS ONLY)

QTY	DESCRIPTION
1	MARKING TOOL
1	3/32" DRILL BIT
1	1/8" DRILL BIT
1	5/32" DRILL BIT
1	3/16" DRILL BIT
1	7/32" DRILL BIT

IF YOUR GEN 1 OR GEN 2 REAR WING KIT IS ALREADY INSTALLED, YOU WILL NEED TO REMOVE THE UPPER HATCH MOUNT AND FACTORY SPOILER IN ORDER TO DRILL THE UPPER HATCH BRACKET AND/OR SNAKE OUT THE FACTORY BRAKE LIGHT HARNESS.

Please revert back to the Rear Wing Kit Install Guide for steps on how to remove your factory spoiler and upper hatch bracket which can be found on the product page <https://www.aerofabb.com/products/competition-series-rear-wing-kit-mk7-mk7-5-gti-r>.

MARKING YOUR HOLES (GEN 1 ONLY)

With your upper hatch mount removed, line up the two inner holes on the third brake light bracket with the two aerofabb badge rivets on the bottom of the upper hatch mount. The inner holes on the brake light bracket should slide over top of the excess rivet pins locking the brake light into position. Using your **marking tool**, mark through the outer holes on the brake light bracket and onto the bottom of the hatch mount. Verify that your holes are marked correctly.

DRILLING YOUR HOLES (GEN 1 ONLY)

Using a **drill**, start with a **3/32" drill bit** to create pilot holes through your markings on the hatch bracket. Step up in sizes to enlarge your holes by going from **1/8" - 5/32" - 3/16" - a final size of 7/32"**.

FASTEN YOUR THIRD BRAKE LIGHT

(*OPTIONAL: Apply a small amount of medium threadlocker to the two **M5 X 12MM Bolts.***) Fit the inner holes of your brake light bracket back over top of rivet pins which will fix your brake light into position. Using a 3mm Hex Wrench, thread the M5 bolts through the upper hatch mount and into the brake light brackets outer holes and tighten. (DO NOT OVERTIGHTEN)

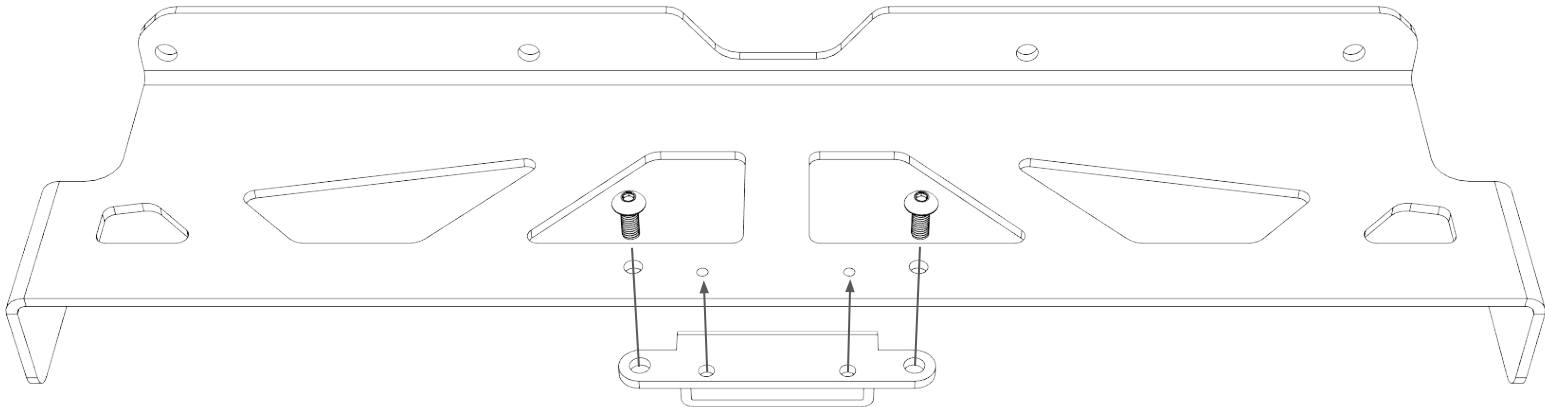

ROUTING YOU CONNECTOR

With your third brake light securely installed onto the upper hatch bracket, loosely fasten your upper hatch bracket back onto your wing uprights. Feed the brake light harness through the left inner cut out as shown in red. Pull the factory harness from the car and through the OEM brake light cut out of your factory spoiler. Connect the brake light and test to ensure it functions properly. *There should be no pulse pattern of flicker when pressure is applied to the brake pedal, this is a steady signal illumination brake light.*

REINSTALL

TUCK ANY EXCESS HARNESS UP INSIDE YOUR FACTORY SPOILER ENSURING NOT TO PINCH BETWEEN THE HATCH BRACKET AND BODY WHEN TIGHTENING Please revert back to the Rear Wing Kit Install Guide for steps on how to reinstall your factory spoiler and upper hatch bracket to complete this installation which can be found on the product page <https://www.aerofabb.com/products/competition-series-rear-wing-kit-mk7-mk7-5-gti-r>.

