

FALCON 352E Specification

3" x 3" Portable Self Priming Centrifugal Pump with Lombardini /Kohler Diesel Engine



Applications

- Water
- Waste water
- General Purpose Pumping
- Chemical Handling

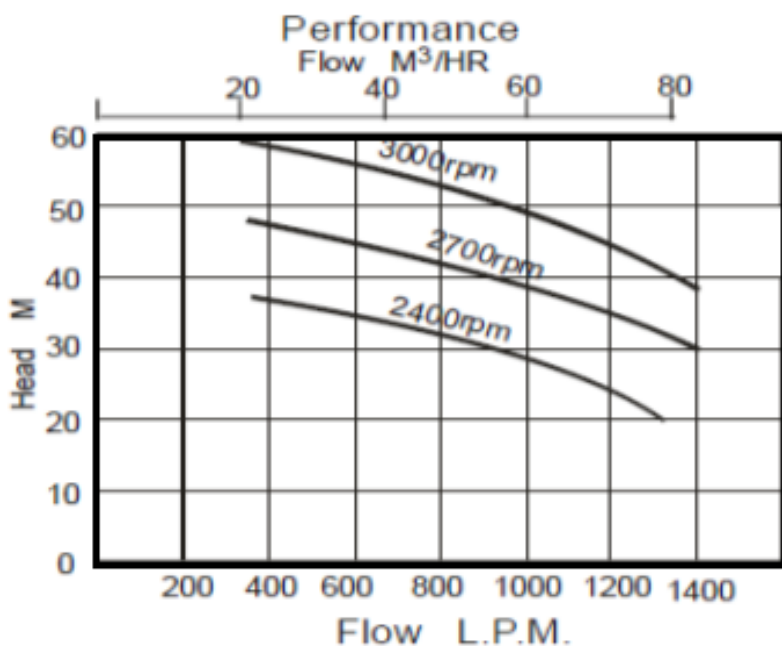

Pump details

- Robust Cast Iron Construction
- Pump and Engine are flexibly coupled for easy maintenance
- Solids Handling up to 35 x 16 mm
- Standard mounting is a fabricated steel baseplate with fixing holes. Other mounting options include a 2 wheel site trolley.
- Self Priming to 5 m
- Integral non return valve
- Renewable wear plate volute
- Carbon/Ceramic mechanical seal
- Steel shaft running in two 'sealed for life' ball bearings
- Screwed BSP connections
- Optional extras available including :
Spares Kits
Hoses
Special Couplings
Remote throttle/stop controls
Case
Packing

Engine details

Powered by a high quality Lombardini / Kohler two cylinder air cooled industrial diesel engine model 9LD625-2 developing 18.8 kw, at a nominal 3000 rpm complete with Electric start, 14 litre 3 hour fuel tank, throttle control, silencer, oil bath air cleaner, replaceable element oil and fuel filters. Set is supplied with Pump and Engine Operating and Instruction Manuals.

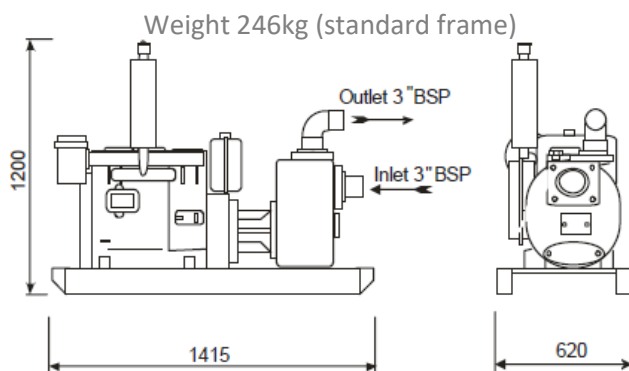

PumpSets Ltd

Unit 2, North Way, Walworth Business Park,
Andover, Hampshire, SP10 5AZ, United Kingdom

tel : +44 (0) 1264 332004
email : enquiries@pumpsets.com
web : www.pumpsets.com