



XR Seatpost Spring Change

This guide demonstrates how to replace the upper and lower springs on the Kinect XR Seatpost. These steps also apply to the Kinect XL2 seatpost model.

XR Spring Selection Guide

Spring Combination		Rider Weight (lbs.)	
Upper	Lower	Road/Gravel	E-bike
Purple	White	80-150	100-150
Black	White	150-180	150-180
Purple	Yellow	180-220	170-210
Black	Yellow	200-240	190-230
Purple	Red	240-280	220-260
Black	Red	270-320	250-320

Required Tools

- 3mm hex key
- 4mm hex key

Lower Spring Removal

1. Remove lower side link screws (A) with a 3mm hex key.
2. Undo preload bolt (B) with a 4mm hex key.

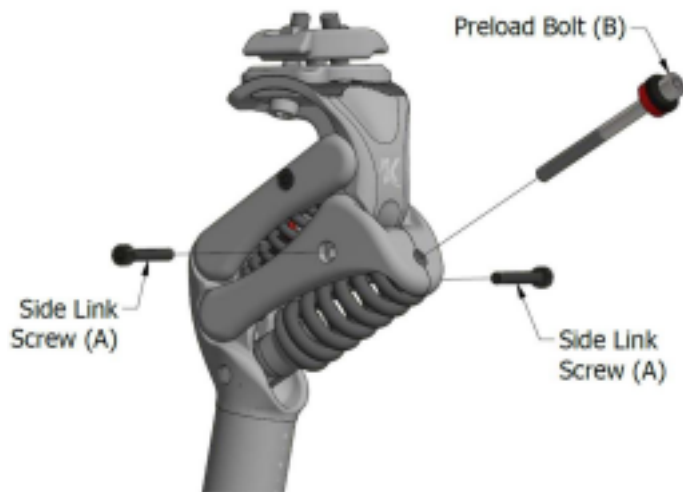

3. Pull the left and right lower side links (C) off one at a time.

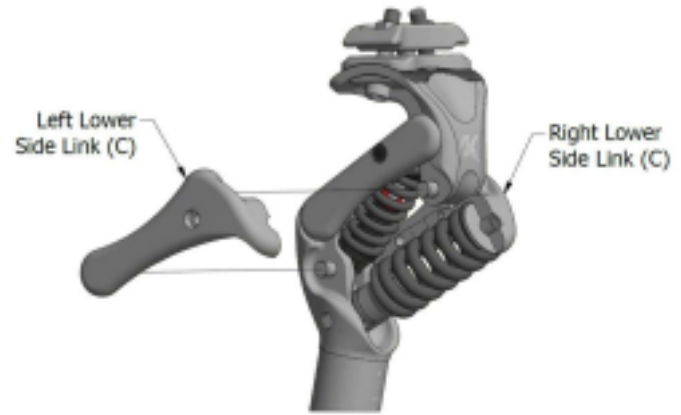

4. Remove lower spring guide bushing (D), 2" lower spring (E), and Lower Spring Adapter (F).

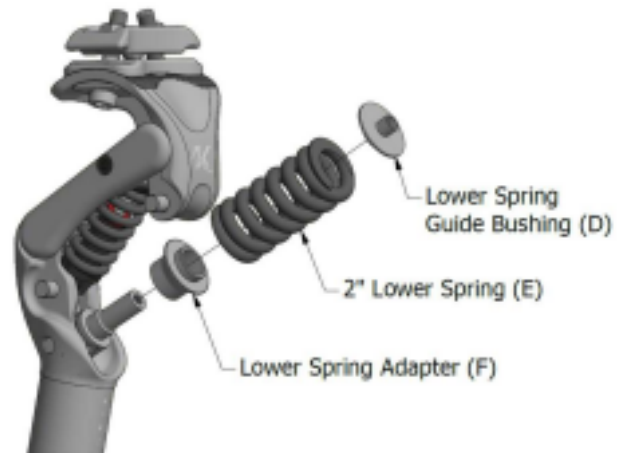

Upper Spring Removal

5. Pivot the upper links and rear link assembly forwards to access the upper spring assembly.

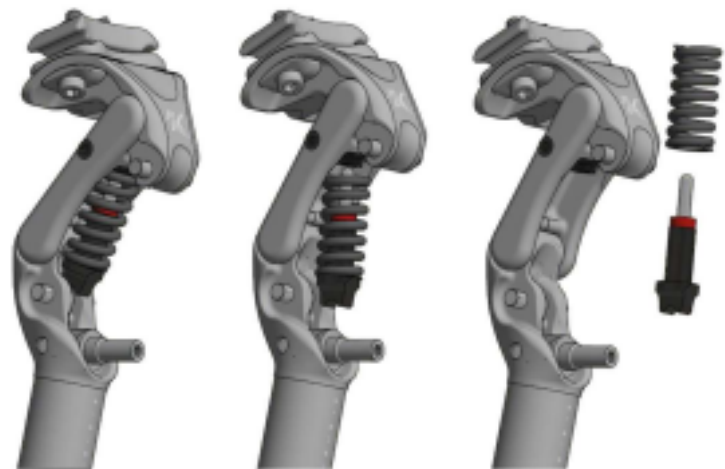

6. Remove the upper spring guide assembly (G) and 1.5" upper spring (H).

Upper Spring Installation

- Ensure that upper spring guide bushing (J) is in place and that the bottom out elastomer (K) is installed on the upper spring guide assembly (G).
- Note: If converting a Large seatpost to an XR, remove white nylon spacer and do not use orange striped upper spring.

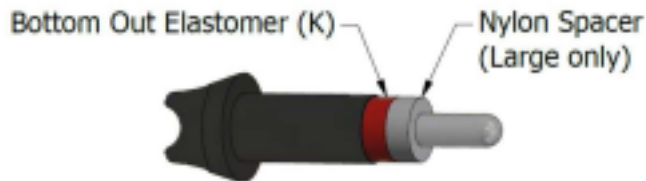

- Place 1.5" upper spring (H) onto the upper spring guide assembly (G).

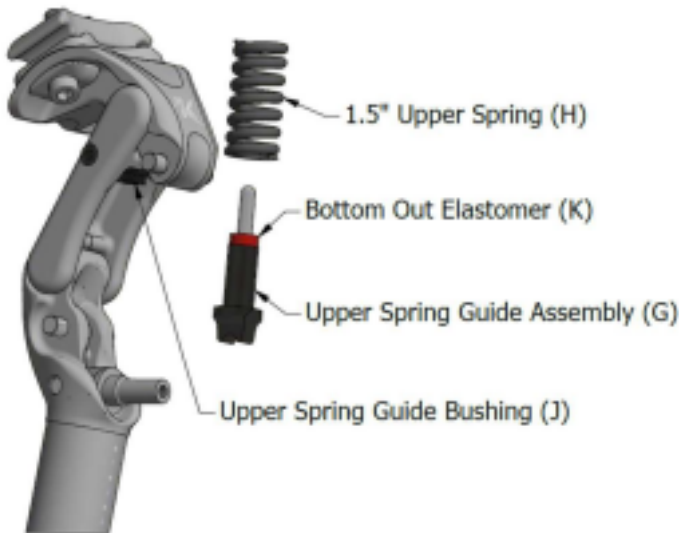

- Install upper spring assembly by inserting the top first into the Upper Spring Guide Bushing (J), and then push the bottom into place over the stainless pivot pin.

Lower Spring Installation

- Install lower spring adapter (F), 2" lower spring (E), and lower spring guide bushing (D).

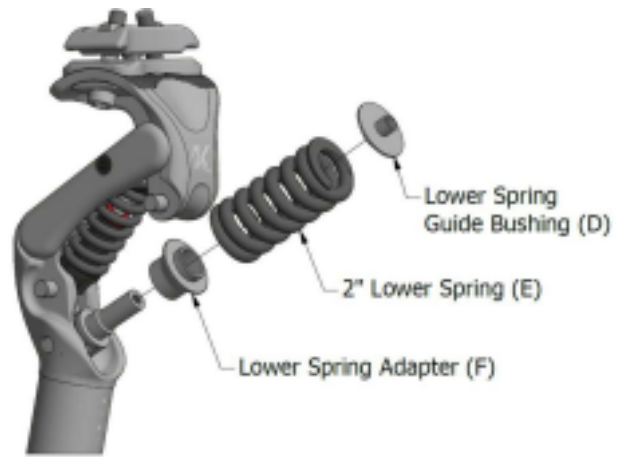

- Install Lower side links (C).

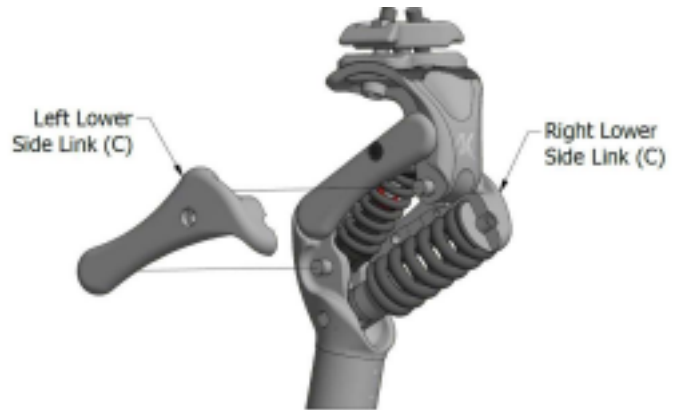

- Lightly thread in side link screws (A) and preload bolt (B).
- Tighten side link screws (A) to 2.4Nm (21in-lbs).



- Set preload to desired value. We recommend starting at setting 1.

Customer Support

For assistance, please contact us via email or