

iQSLIM TREAD

-INSTRUCTION MANUAL-



Read Instructions Before Use
Max Weight 100kgs/220lbs

CONTENTS

1. Product Introduction
2. Startup
3. Installation Instructions
4. User Instruction
6. Emergency Stop Function
7. Error Code and Handling
9. Safety precautions
13. Routine Maintenance
14. Warranty



★ Leaders in Professional Marketing and Demonstrating ★
101-127 Commercial Drive, Calgary, AB, T3Z 2A7
1-877-387-7770 www.redferment.com

1. Product Introduction

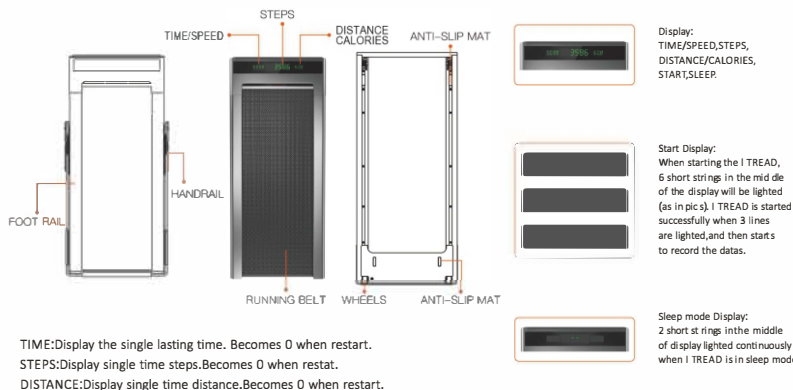

TIME : Shows the duration of a single exercise, and returns to zero after restarting.

STEPS: Displays the cumulative number of steps in a single exercise and returns to zero after restarting.

DISTANCE : Shows the number of accumulated mileage in a single exercise and returns to zero after restarting.

SPEED: Shows the current running speed.

CALORIES: Shows a single exercise accumulating calories, resets to zero.

Display:

The left window shows the SPEED speed / TIME time (switches once every 6 seconds)

Intermediate window shows STEPS

Right window shows DISTANCE miles / CALORIES calories (6 seconds switch)



Startup:

During the start of the iQ Slim Tread, the middle position of the display is three horizontal and six grids. The green prompt line will be displayed in sequence. Successful start is three horizontal and six grids. The green cue line continues to display and begins recording motion data.



Sleep mode :

When the iQ Slim Tread is asleep, two prompt lines will be displayed in the middle of the display and will continue to flash.



Specifications

| | |
|------------------|---|
| Product |  |
| Color | Silver or Pink |
| N.W/G.W | 29kg |
| Size | 145cm*67cm*9cm |
| Running area | 120cm*46cm |
| Ground Clearance | 4.7 cm – 9 cm |
| Max power | 560W |
| Max speed | 8km/h |

Installation Instructions:

iQ SLIM TREAD is completely assembled.

Assembly instruction for users who buy handrail separately only.

Assembly Instruction for the handrail:

- 1.Put iQ SLIM TREAD face down,make sure there are no sharp items and no impurity on the floor, to avoid scratches of the surface of the iQ SLIM TREAD.
- 2.Put handrail face down,overlap both sides of iQ SLIM TREAD. Make sure the holes are aligned.
- 3.Lock support parts in both sides with screws. 8 screws in total.
- 4.Lock support parts in both sides with screws, set it up.
- 5.Overlap the holes of long support part (the part which stretches across the running belt), then lock the screws in the first row and then lock the screws in the last row. Finish assembly.
- 6.Put iQ SLIM TREAD face up,plug in and start to enjoy the iQ SLIM TREAD.

*: - Before first use, treadmill running belt must be lubricated with supplied lubrication oil. Apply 1/4 bottle to each side of the running belt, along the stride path from the speed are to the constant speed area. Keep oil within the stride path area only.

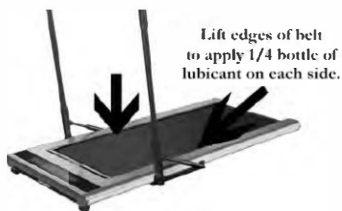

User Instruction

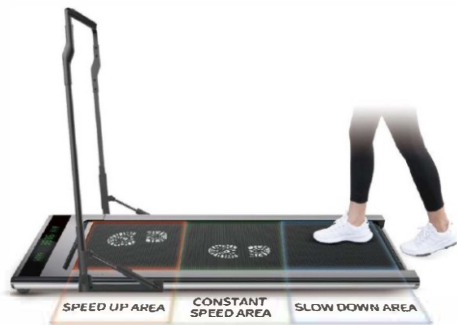

How to Start

1. Put the iQ Slim Tread on a flat open area and ensure a 200cm x 100cm safe area is around it. Do not use mats or carpeting underneath.
2. Plug in unit, display will light up.

3. Take three steps from the front to the back to start up unit. Display will light up accordingly. (As per diagram)



the 1st step



the 2nd step



the 3rd step

Three step start and intelligent remote start, the display will show in the same way, as seen in the diagrams above.

In the standby state, the user stands in the middle of the platform, presses the mode button and the unit starts automatically.

Incorrect way to start up

1. Use one foot to step forward.
2. Distance between two steps is smaller than 5cm or bigger than 10cm
3. Children should not try and start unit. Usually feet are too small to start.
4. To slow to start the iQ Slim Tread at time intervals between 2 steps cannot be longer than 1.5 second can cannot be started if steps not continuous.
5. Unit has not woken up from sleep mode.

How to speed up

The user moves to the acceleration area and speed will increase automatically. When user puts handle down, the maximum speed is 6km/h; when we put handle down, the max speed is 8km/h.

Constant Speed

Walk/run on the middle part of constant speed area, keeps constant.

How to accelerate in human body sensor mode?

The user moves from the acceleration area to constant speed area and walking for 5 seconds, and then it can be decelerated and maintained at a constant speed.

How to slow down in the constant speed area?

The user moves from constant speed area to deceleration area and walks for about 5 seconds and the speed will decelerate. If you continue to move for about 5 seconds in the deceleration area, the machine will gradually stop running. If you do not need to stop, you can keep walking in the constant speed area and the deceleration.

How to stop in human body sensor mode?

A. How to stop in the acceleration area?

The user moves from the acceleration area to constant speed area and walking for 5 seconds; then moves from constant speed area to deceleration area and walks for 5 seconds, the machine will stop automatically.

B. How to stop in the constant speed area.

The user moves from constant speed area to deceleration area and walks for about 5 seconds, the speed will decelerate. If you continue to move for about 5 seconds in the deceleration area, the machine will gradually stop running.

Emergency stop function:

During use, the armrest is pulled back more than 90 degrees vertically to stop the machine.

The display shows OFF (Then it needs user to leave machine and restart the machine when ready)



Error code and handling

| Error code | Reason | Solutions |
|------------|---|---|
| E01 | Communication failure is mainly the fault of the upper control and communication line | Replace the upper control and signal lines |
| E02 | Communication failure, mainly control board Communication failure | Change the control board |
| E03 | Stall protection, motor failure | Change the motor |
| E04 | Over-current protection | The friction between the running belt and the running board is too large. Lubricate running belt. See initial use setup. |

Sleep mode

When finishing exercise on iQ Slim Tread, the system enters the sleep mode after 5 minutes of standby mode. At this time, the display shows two horizontal bars and flashes.

Wake up

In the deceleration area of iQ Slim Tread, the heel does not leave the running belt and evenly raises the foot within 5 seconds to wake up machine. During the wake-up process, the display will light up as below pic 1, pic 2 and pic 3. Now the unit wakes up.



Eight strings two checks



Eight strings four checks



Eight strings six checks

Wake up in the wrong ways includes the following situations.

(1) Wrong area: the wake-up action must be performed in the deceleration area, and cannot be completed in acceleration area and normal speed area.

(2) The action is incoherent: the wake-up action needs to be continuously tapped three times. When the three actions are completed for more than 5 seconds, it fails to wake up, and the display area re-displays the two horizontal lines that flash, and must wake it up again.

Automatic protection

1) iQ Slim Tread will stop automatically and starts self-protection if it runs continuously for 100 minutes or more.

Handrail lift

(1) Handrail Installation Instructions: Refer to II. Installation Instructions

(2) Automatic handrail instructions:

iQ Slim Tread intelligent handrail adopts gravity hydraulic technology, which can realize automatic lifting when it reaches a certain height.

A. Lift the handrail to a certain height and it automatically rise to the appropriate height;

B. Put the handrail down to the corresponding position and the handrail will automatically retract to the original position.

Special note: When the handrail is raised, the max speed of the iQ Slim Tread will be 8KM/h. When the handrail is folded, the max speed is 6km/h.

Storage

The weight of the iQ Slim Tread is only 24kg and the front end of the walking machine has a pair of moving wheels. When moving the unit, user can lift the end of machine and push the machine by moving wheels to any direction

(1) Horizontal storage:

The thinnest part of the iQ Slim Tread is 4.7cm from the ground, and the highest height is 9cm away from the ground. It can be freely accommodated in any space that meets this size, such as under the sofa and under the bed (where space permits);

(2) Wall storage:

iQ Slim Tread walking machine can be put to lean on the wall and needs only 0.06 square meter .You can save much space in the room.

User Safety Instructions

To avoid unnecessary injury, please follow the instructions above and read the following safety instructions before using the iQ Slim Tread. We do not bear the problems or consequences caused by abnormal operation and use.

1. Do not insert any other item in any part of iQ Slim Tread to avoid damage.
2. When starting to use the iQ Slim Tread to exercise, please ensure that your health is in good condition. Physical discomfort (such as dizziness, headache, ligament injury, joint artificial replacement, etc.) or those who have health issues should consult a physician before exercising.
3. Please carry out proper and regular exercise according to your physical condition. Mistakes and excessively high intensity exercises will not benefit your health. Any strenuous exercise is mpt recommended for 40 minutes after meals.
4. This product is not suitable for children and the elderly. Children should be monitored and ensure proper use unless they are effectively monitored or directed.
5. This product is suitable for home use, not suitable for professional training and testing, and can not be used for medical purposes.

6. Please check carefully before use and place the product on a clean, plain open floor to ensure that there are no sharp objects and obstructions nearby.
7. Do not use it near water and heat sources or under strong light.
8. When using, please wear comfortable clothes, avoid wearing any decoration (such as decorative necklaces, decorative hats, etc.) and childrens toys to avoid unnecessary accidents.
9. When using, please do not put your hands, feet, other objects under the body of the walking machine and the gap between the running belt and the side strip.
10. This product is rated for one person use. Multiple people using will void warranty.
11. Please use original accessories, it is forbidden to replace, disassemble and use unsuitable accessories.
12. The maximum load capacity of this product is 100KGS/220 lbs, and it is forbidden to use more than 100KGS/220lbs.
13. This unit should not be used for an extended period of time. It is recommended to rest it for 30 mins after 1 hour use. If used for a long time, it will cause overheating of the treadmill and may cause electrical failure.
14. Unplug the power after using the iQ Slim Tread. If you do not use it for a long time without cutting off the power, it may damage the equipment.
15. When using this product please ensure that the strong magnet of the foot protector and the wall fixing parts are firmly absorbed after the product is used and then should not be moved.
16. Warm-up exercises should be done before using unit otherwise it will easily cause strain on the thighs and calves. Pressing the leg, squatting, stretching the muscles, flexing and stretching the joints can increase the temperature of the muscles.

In addition, the lower walking speed should also gradually slow down until the running of the walking machine stops, so as to avoid vertigo and fall or slip.

17. If there is a problem with the electronic system that causes the iQ Slim Tread to suddenly accelerate or the speed automatically increases, please take the device away from the left or right side of the unit and immediately unplug the power.

18. The power cable of the iQ Slim Tread is a special one. If the power cable is damaged, it must be replaced by a certified technician from Redfern Ent. Please do not add wire in the middle of the power cable, do not extend or replace the power cable, do not stack heavy objects on the power cable or place the cable close to the heat source with high temperature. Do not use the multi-hole socket, otherwise it will cause fire due to poor contact. Or potentially electric shock and injury.

Important

- (1) Please use a qualified power outlet and ensure that the plug is not loose. If the plug and socket are not compatible, please replace the socket of the matching plug in time to avoid the danger.
- (2) Please use 110V-120VAC stable power supply.
- (3) It is forbidden to contact the power cable with the roller, moving wheels, running belt etc. And it is forbidden to use the damaged plug.
- (4) Do not use this product outdoors, in high humidity, strong light or direct sunlight.
- (5) Do not step on the display of this product.
- (6) Do not stack heavy objects on top of this product.
- (7) Do not forcibly disassemble any accessories of this product.
- (8) Do not forcibly cut off the power during the process.
- (9) When cleaning and maintaining this product, please cut off the power supply in advance and ensure that there is no water seepage to avoid electrical failure.
- (10) When not in use please turn off the power and unplug the plug.

Prohibition

1. Do not use in a state where the outer casing is cracked or ruptured (the internal structure is exposed). - Otherwise accidents or injuries may occur.
2. Do not jump up and down during exercise. - may be injured as a result of a fall.
3. Do not use or store in places with heavy humidity and places where water droplets are drenched in the vicinity of the bathroom and near the bathroom.
4. Do not use or store on high-temperature places such as places where there is direct sunlight, around the stove, and heating appliances such as electric carpets. One may cause leakage or fire.
5. Do not use when the power cord or power plug is damaged or the socket of the socket is slack. - otherwise it may cause fire or electric shock.
6. Do not use iQ Slim Tread for 2 or more people at the same time. Be careful not to let the people around you close during use; otherwise, accidents or injuries may occur due to falling.
7. Do not use the device by yourself. - accidents or injuries may occur.
8. Avoid contact with water! Do not expose the main body and the motor core to water or beverage erosion. - may cause electric shock or fire.
9. People who do not exercise regularly should not suddenly do strenuous exercise.
10. Do not use after eating or fatigue, just exercising or physical condition is not normal. - may cause damage to health.
11. This product is suitable for home use and is not suitable for use in unspecified places such as schools and gymnasiums. - risk of injury.
12. Do not use at the same time when eating or doing other activities.
13. Do not use with alcohol.
14. Do not use the product with a hard object in your pocket. One may cause an accident or injury.
15. Please check the power plug for foreign matter such as debris, garbage or moisture before use. - may cause electric shock or injury.
16. Unplug the power cord when not in use. Dust and moisture will deteriorate the insulation, resulting in electric leakage fire.
17. If the product is left unattended or in use, children and pets are prohibited from approaching. - may cause an accident or injury.

Routine maintenance

The iQ Slim Tread fully upgrades the running board and running belt technology, the running plate density and lubrication degree is increased by 10-15 times, the frictional resistance coefficient (C_x) is 50% lower than that of the traditional treadmill, and the walking machine is oiled when it leaves the factory. When it is used for 30 hours or 30 days, the running belt should be checked for lubricant. If you feel the lubricant, you do not need to add lubricant; if you touch the surface, there is a strong dry feeling, as shown in the figure below, evenly lubricate the inside of the machine with the side of the belt.

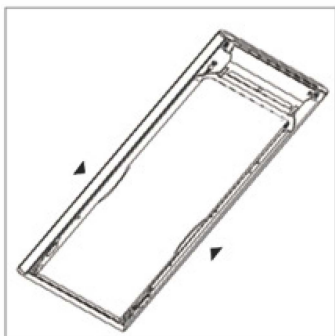

Warning: Before cleaning or maintaining the product, be sure to unplug the power plug of the unit.

Cleaning: Comprehensive cleaning will extend the life of the treadmill. Remove dust regularly to protect parts. . Be careful not to spill water on the electrical components and under the running belt. Be sure to unplug the machine before moving the motor cover. When the machine is not used for a long time, it is necessary to cut off the power supply. When cutting off the power, do not pull on the power cord; you must grab the power plug to remove some of the core wires in the power cord. In order to prolong the service life of the machine motor, this product should not be used for more than 1 hour for a long time. When the walker malfunctions, immediately replace those defective parts or leave the machine idle until repair.

iQ SLIM TREAD WARRANTY

CONGRATULATIONS ON THE PURCHASE OF YOUR IQ SLIMTREAD
PLEASE READ THE FOLLOWING WARRANTY INFORMATION PRIOR TO FIRST USE.
THIS IQ SLIMTREAD COMES WITH A LIMITED 1 YEAR WARRANTY (FROM ORIGINAL DATE OF PURCHASE) AGAINST DEFECTS IN MATERIALS AND WORKMANSHIP. THE WARRANTY IS NOT VALID IF THE PRODUCT HAS BEEN MISUSED OR DAMAGED IN ANY WAY THAT IS BEYOND THE CONTROL OF REDFERN ENTERPRISES. THIS PRODUCT IS FOR HOUSEHOLD USE ONLY.

THE WARRANTY APPLIES ONLY TO THE PRODUCT; REDFERN ENTERPRISES IS NOT RESPONSIBLE IN ANY WAY FOR LOSSES, DAMAGES OR INCONVENIENCE CAUSED BY EQUIPMENT FAILURE. WARRANTY VALID FOR ORIGINAL PURCHASER ONLY.

FIRST 30 DAYS FROM DATE OF PURCHASE

ANY IQ SLIMTREAD RETURNED TO REDFERN ENTERPRISES MUST BE PACKED AND SHIPPED BY A REDFERN ENTERPRISES APPROVED CARRIER TO MAINTAIN THE VALIDITY OF THIS WARRANTY. THE WARRANTY COVERS IN HOME SERVICE (AT REDFERN ENTERPRISES DISCRETION), PACKING AND RETURN SHIPPING TO REDFERN ENTERPRISES, PARTS AND LABOUR FOR THE REPAIR WORK AND RETURN SHIPPING TO THE PURCHASER, WITHIN THE FIRST 30 DAYS FROM ORIGINAL DATE OF PURCHASE. CONTACT REDFERN ENTERPRISES

ALL WARRANTY SERVICES PAST 30 DAYS FROM ORIGINAL DATE OF PURCHASE

THE CONSUMER WILL BE RESPONSIBLE FOR ALL SHIPPING CHARGES TO AND FROM REDFERN ENTERPRISES FOR ALL WARRANTY REPAIRS. THE COST OF PARTS AND LABOUR ARE COVERED UNDER 1 YEAR WARRANTY. UPON INSPECTION BY REDFERN ENTERPRISES; IF THE UNIT IS PROVED DEFECTIVE IT WILL BE REPAIRED OR REPLACED AT THE DISCRETION OF REDFERN ENTERPRISES. CONSUMER MUST PROVIDE ORIGINAL PROOF OF PURCHASE TO VALIDATE WARRANTY. A RETURN SHIPPING FEE OF \$49.99 WILL BE APPLIED.

ALL SERVICES COVERED BY THIS WARRANTY MUST BE PRE-APPROVED BY REDFERN ENTERPRISES. TO INITIATE WARRANTY SERVICES; CONSUMER WILL CONTACT REDFERN ENTERPRISES TOLL FREE AT 1-877-387-7770 OR CALGARY LOCAL AT 403-735-5130; BETWEEN 9:00 AM -5:00 PM MST, MONDAY - FRIDAY (CLOSED ALL STATUTORY HOLIDAYS) OR EMAIL INFO@REDFERNENT.COM

1 Year Limited Warranty



Redfern Ent. is not responsible for any injuries due to incorrect use of this product. Please read manual thoroughly to avoid injury, misuse or damage to the unit and to user.