

- | | | | |
|-----------|------------------------------------|---------------|---------------------------------|
| DE | Montageanleitung | GB USA | Assembly instructions |
| FR | Notice de montage | I | Istruzione di montaggio |
| NL | Handleiding voor de montage | PL | Instrukcja montażu |
| CZ | Montážní návod | SK | Návod na montáž |
| HU | Szerelési útmutató | RO | Instrucțiuni de montaj |
| TR | Montaj talimat | RU | Инструкция по монтажу |
| PT | Instruções de montagem | ES | Instrucciones de montaje |

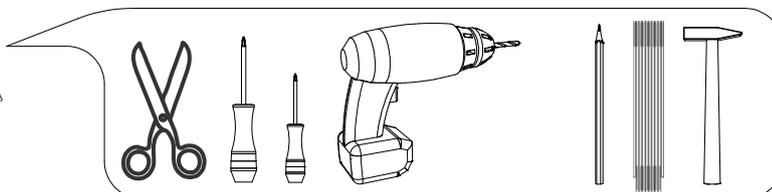
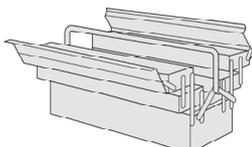
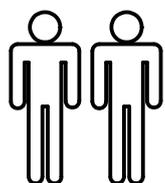

IT**Avvisi di sicurezza**

Durante il montaggio del mobile, il triangolo segnala i seguenti avvisi.

**1**

I tasselli forniti (viti e tasselli) sono adatti solo a murature pieni (calcestruzzo o mattoni). Qualche tipo di muratura richiede un tassello speciale. Se necessario, si prega di consultare un professionista qualificato.

12

Tenere lontano dai bambini pezzi di ferramenta come viti, copriviti ecc. per evitare un eventuale soffocamento.

13

Seguire scrupolosamente lo schema di montaggio.

DE**Sicherheitshinweise**

Das Dreieck erinnert Sie während der Montage an die folgenden Hinweise.

**1**

Das beigegefügte Wandbefestigungsmaterial (Dübel und Schrauben) eignet sich nur für festes Mauerwerk (z.B. Beton oder Ziegelwände). Für andere Wandaufbauten sind eventuell Spezialdübel und andere Schrauben notwendig. Ziehen Sie gegebenenfalls eine Fachkraft zurate.

12

Achten Sie darauf, daß Kinder keine Kleinteile, wie z. B. Muttern, Abdeckkappen oder Ähnliches in den Mund nehmen. Sie könnten sie verschlucken und daran ersticken.

13

Gehen Sie bei der Montage des Artikels sorgfältig vor und halten Sie sich an die Montageanleitung.

UK**USA****Safety instructions**

The triangle reminds you during the installation of the following notes.

**1**

The enclosed wall mounting materials (dowels and screws) are only suitable for solid masonry (e. g. concrete or brick walls). Special dowels and other screws may be necessary for other wall constructions. If necessary, please consult a qualified professional.

12

Ensure that children do not put any small parts such as nuts, caps or the like in their mouth. They could swallow and choke on them.

13

When assembling the product, please proceed with caution and comply with the assembly instructions.

RU**Правила техники безопасности**

Во время монтажа треугольник служит напоминанием для следующих указаний.

**1**

Входящий в комплект поставки материал для крепления на стене (дюбели и болты) предназначен только для прочных каменных стен (например, бетонных или кирпичных). Для других типов стен используйте по мере необходимости специальные дюбели и другие болты. По мере необходимости обратитесь за помощью к специалистам.

12

Следите, чтобы мелкие детали, например гайки, крышки и т. п., не попали в рот ребенка. Дети могут их проглотить и задохнуться.

13

При монтаже изделия будьте внимательны и соблюдайте инструкции по монтажу.

CZ**Bezpečnostní pokyny**

Trojúhelník vám během montáže připomene následující pokyny.

**1**

Příložený materiál pro montáž na stěnu (hmoždinky a šrouby) je vhodný jen pro pevné zdivo (např. betonové nebo cihlové stěny). Pro jiné skladby stěn budou případně nutné speciální hmoždinky a jiné šrouby. Poradte se případně s odborníkem.

12

Dbejte na to, aby děti nedávaly do úst žádné drobné díly jako např. matice, krytky a podobně. Mohly by je spolknout a udusit se.

13

Při montáži výrobku postupujte pečlivě a dodržujte pokyny uvedené v montážním návodu.

FR**Avis de sécurité**

Ces avis vous seront rappelés durant le montage par ce triangle.

**1**

Les vis et chevilles jointes sont prévues uniquement pour des murs en béton ou des murs en briques. Pour les autres types de murs veuillez utiliser des vis et chevilles adaptées et si nécessaire consultez un quincaillier.

12

Tenir éloignés les enfants pour éviter qu'ils ne mettent pas de petites pièces dans leur bouche, ils pourraient les avaler et étouffer.

13

Durant le montage de votre meuble veuillez procéder avec prudence et respecter les instructions de montage.

TR**Güvenlik uyarıları**

Durante a montagem do móvel, o triângulo indica as seguintes advertências.

**1**

Teslimat kapsamındaki duvar tipi sabitleme materyali (dübel ve vidalar) sadece beton ve tuğla duvarları gibi sağlam duvar yapıları için uygundur. Başka duvar yapıları için özel dübeller veya başka vidalar gerekli olabilir. Gerekirse bir uzmandan yardım alınız.

12

Çocukların somun, muhafaza kapakçıkları ve benzeri küçük parçaları ağızlarına almamalarına dikkat ediniz. Bunları yutabilirler ve boğulabilirler.

13

Montaj esnasında büyük bir itinayla çalışınız, ürüne dikkatlice çalışınız ve mutlaka montaj talimatına uyunuz.

SK**Bezpečnostné pokyny**

Trojuholník vám počas montáže pripomenie nasledujúce pokyny.

**1**

Příložený materiál pre upevnenie na stenu (hmoždinky a skrutky) je vhodný len pre pevné murivo (napr. betónové alebo tehlové steny). Pre iné steny sú potrebné príp. špeciálne hmoždinky a iné skrutky. V prípade potreby sa poraďte s

12

Dbejte, aby si deti nemohli dať do úst drobné diely, ako napr. matice, krytky alebo podobne. Mohli by ich prehltnúť a zadusiť sa.

13

Pri montáži výrobku postupujte obozretne a dodržujte návod na montáž.

NL**Veiligheidsinstructies**

De driehoek herinnert u tijdens de installatie van de volgende meldingen. 

1

Het bijgeleverde bevestigingsmateriaal (pluggen en schroeven) is geschikt voor vaste muren (bijv. betonnen of bakstenen muren). Voor andere muurconstructies zijn eventueel speciale pluggen en andere schroeven noodzakelijk. Consulteer eventueel een vakman.

12

Zorg ervoor dat kinderen geen kleine stukken, zoals moeren, afdekkapjes of dergelijke in de mond nemen. Ze kunnen ze inslikken en daardoor stikken.

13

Ga bij de montage van het artikel zorgvuldig te werk en houd u aan de handleiding voor de montage.

RO**Instrucțiuni referitoare la siguranță**

Triunghiul vă atenționează să țineți cont în timpul montajului de următoarea indicație 

1

Materialul furnizat pentru montajul de perete (dibluri și șuruburi) este adecvat numai pentru zidărie solidă (de exemplu pereți din beton sau din cărămidă). Pentru alte structuri de pereți, este posibil să fie necesare dibluri speciale, precum și alte șuruburi. Dacă este necesar, consultați un specialist.

12

Supravegheați copiii pentru că pot să introducă în gură piesele mici, cum ar fi de exemplu piulițe, capace sau altele similare. Ei pot să le înghită și se pot asfixia.

13

Procedați cu atenție la montarea produsului și respectați instrucțiunile de montaj.

PT**Avisos de segurança**

Durante a montagem do móvel, o triângulo indica as seguintes advertências. 

1

Os parafusos e buchas fornecidos destinam-se apenas a paredes em betão ou tijolo. Para paredes de outros tipos, use parafusos e buchas adequados. Se necessário, consulte um técnico qualificado.

12

Mantenha longe do alcance das crianças todo o tipo de peças pequenas como parafusos e outras, para evitar o risco de sufocamento.

13

Siga escrupulosamente o esquema de montagem.

PL**Wskazówki bezpieczeństwa**

Trójkąt przypomina o następujących wskazówkach dotyczących montażu. 

1

Załączony zestaw montażowy do zamocowania artykułu do ściany (kołki, wkręty, haki itp.), przeznaczony jest wyłącznie do montażu artykułu na ścianach wykonanych z cegły lub betonu. Przy montażu artykułu na ścianie wykonanej z innych materiałów, należy zastosować odpowiednie do niej zamocowania. W razie wątpliwości prosimy zasięgnąć porady fachowca.

12

Należy dopilnować, aby dzieci nie bawiły się lub też brały do ust żadnych drobnych części mebla, takich jak np. nakrętki, zatyczki itp.. Mogłyby je połknąć i udusić się nimi.

13

Podczas montażu proszę postępować z należytą uwagą i zgodnie z instrukcją montażu. Artykuł może być montowany tylko przez osoby z odpowiednimi kwalifikacjami.

HU**Biztonságtechnikai**

A háromszög a szerelés közben a következő utasításra emlékezteti. 

1

A mellékelt fali rögzít készlet (tiplé és csavarok) csak tömött falazatban (pl. betonfalban, téglafalban) használható. Más faltípusokhoz speciális tiplire és csavarra lesz szükség. Szükség esetén kérje ki egy szakember véleményét.

12

Gondoskodjon arról, hogy a gyerekek ne vehessék a szájukba a kis alkatrészeket, pl. az anyákat, a fed kupakokat stb. Ezeket lenyelve megfulladhatnak.

13

A termék összeszerelésekor körültekintően járjon el, és tartsa magát a szerelési útmutatóban foglaltakhoz.

ES**Avisos de seguridad**

Durante el montaje del mueble, prestar atención al triángulo que informa sobre los siguientes avisos. 

1

Los tornillos y tacos suministrados son adaptos solamente para paredes de ladrillos y cemento. In presencia de paredes de otro material, se ruega consultar un profesional calificado.

12

Mantener alejado de los niños piezas de herramientas como tornillos, ecc para evitar una eventual asfixia.

13

Seguir escrupulosamente el diagrama de montaje.

Service • Dienstverlening • Serwis • Servis • Сервисная служба • Servizio

Name • Naam • Nazwa • Isim • Название • Nom • Nome

Nr. • No. • Номер • Nu.

Тур • Туре • Тір • Тип • Тіро

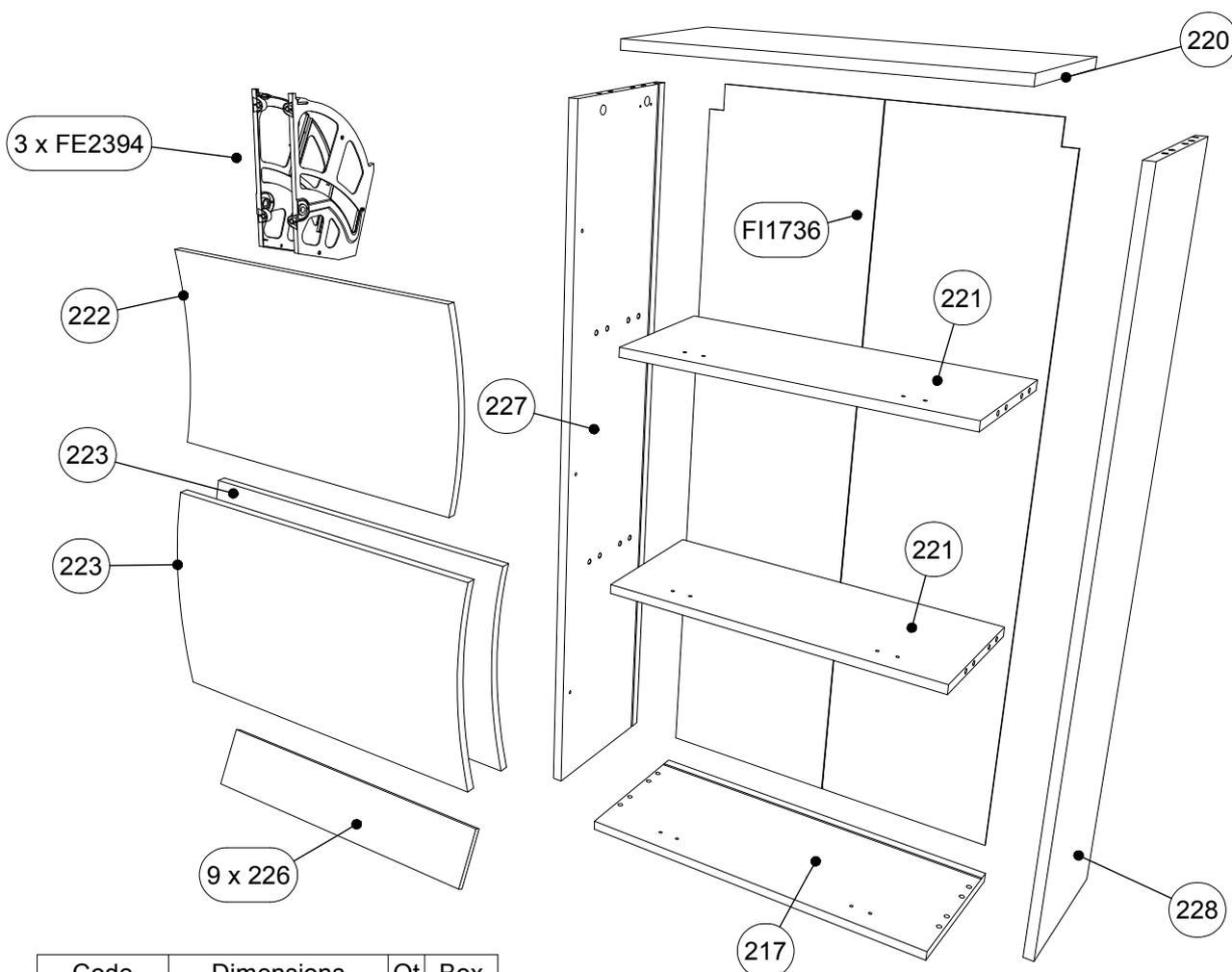
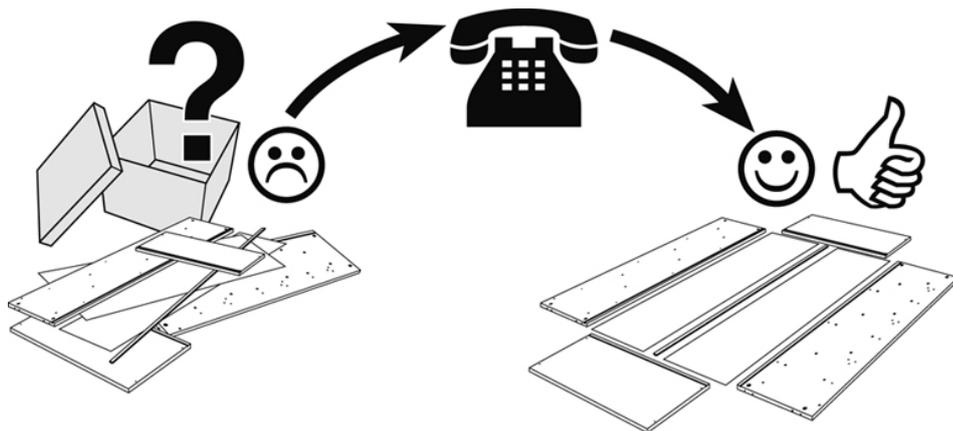

Code	Dimensions	Qt	Box
217	600x250x16	1	1/1
220	600x250x16	1	1/1
221	568x230x16	2	1/1
222	710x397x16	1	1/1
223	710x397x16	2	1/1
226	557x105x10	9	1/1
227	1167x250x16	1	1/1
228	1167x250x16	1	1/1
FE2394		3	1/1
F11736	582x1181x3	1	1/1

FE9205

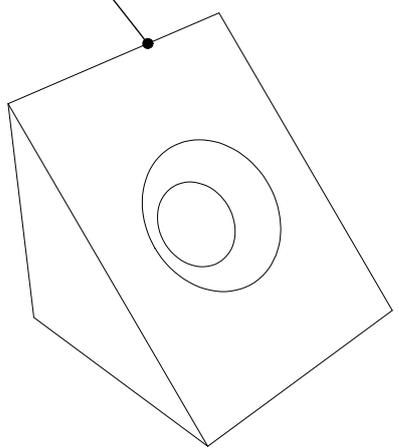

+

FE9208

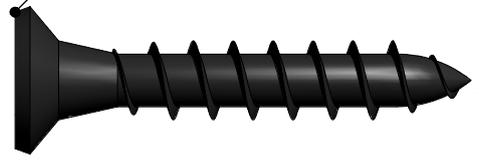

=

FE9205A

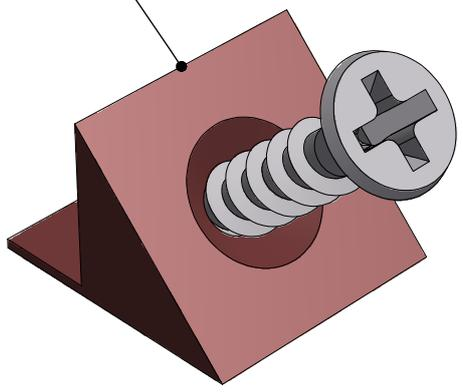

16 x SPL001



12 x FE9602



12 x FE9604



2 x FE9798

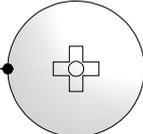

4 x FE9134

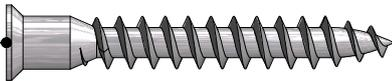

18 x FE9749



4 x FE9728



1Gx FE9403



8 x FE9208



4 x FE9655



18 x FE2312



8 x FE9205



2 x FE9769

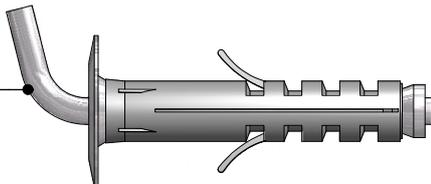

1 x FE9404



2 x FE9834A

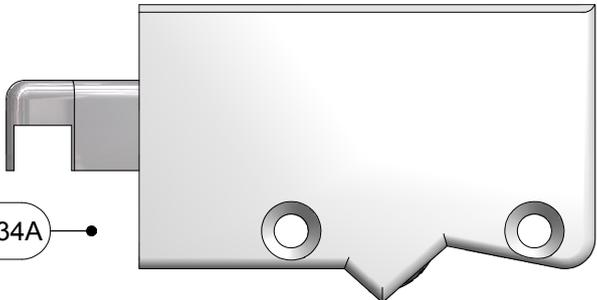

6 x ABA205

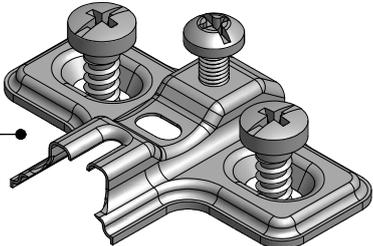

6 x ACE108

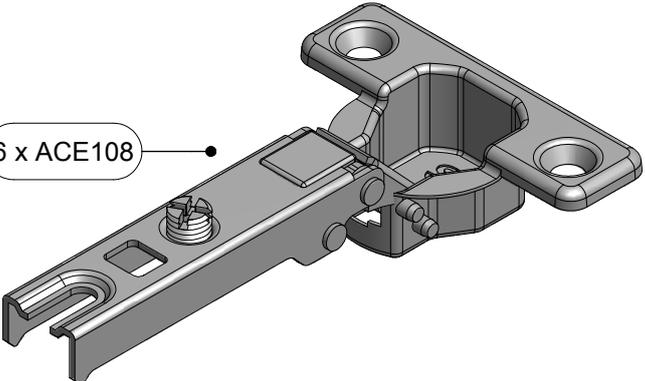

4 x FE9729

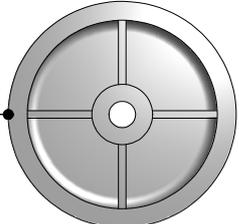

13

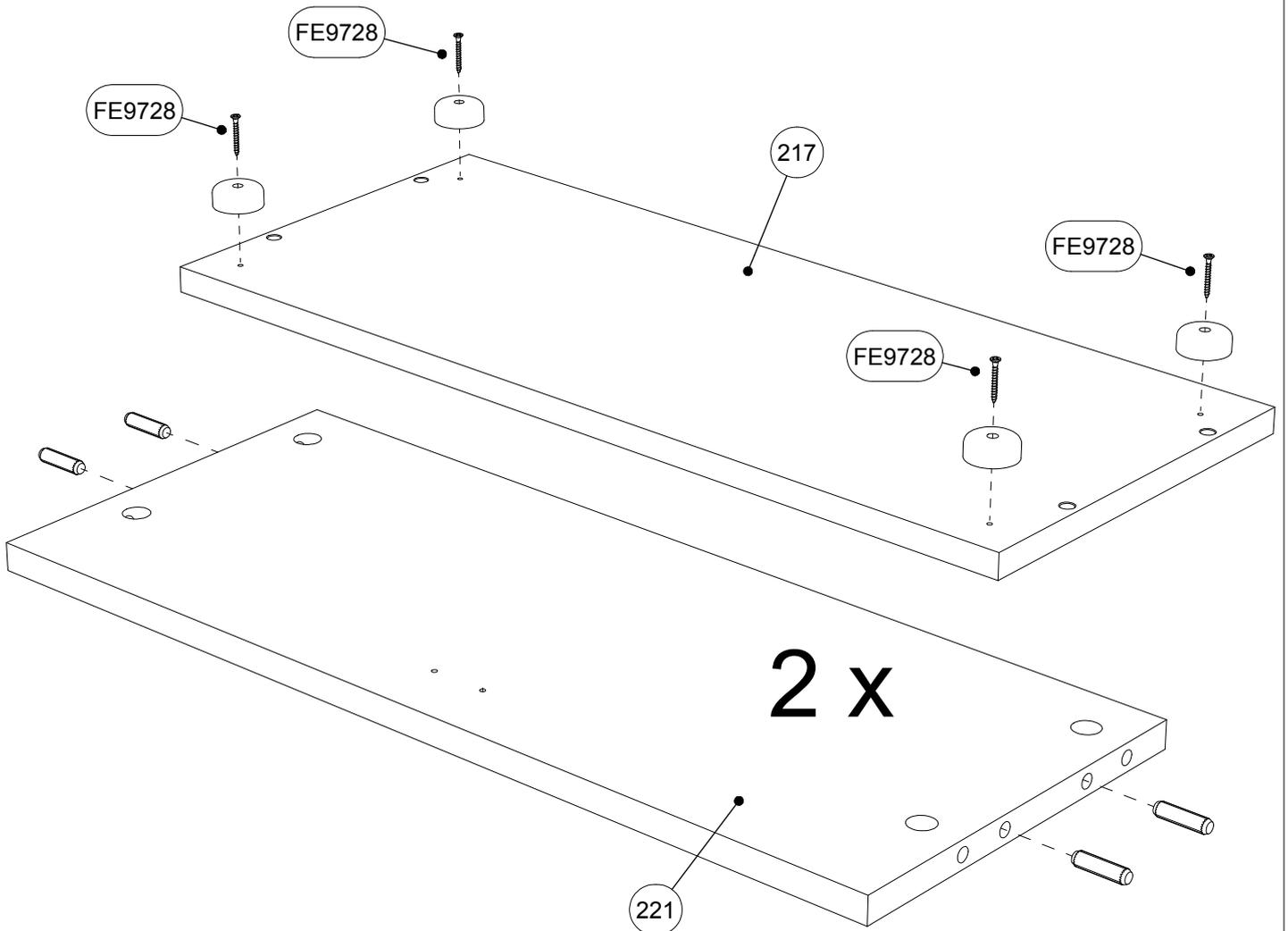
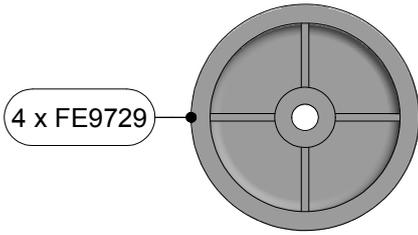
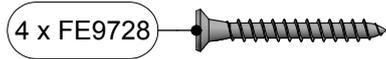
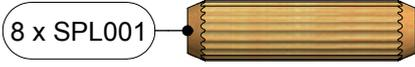
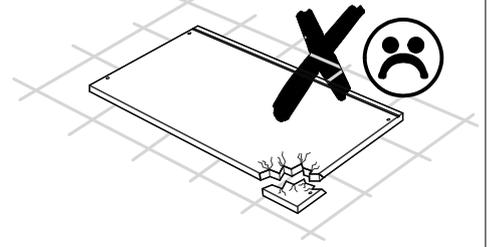
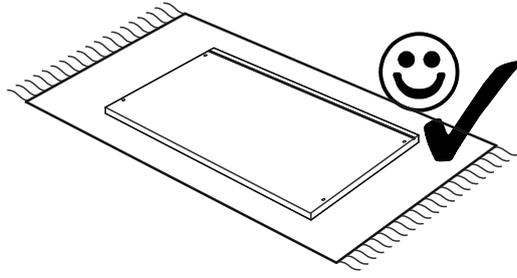

4 x FE9602



6 x ABA205

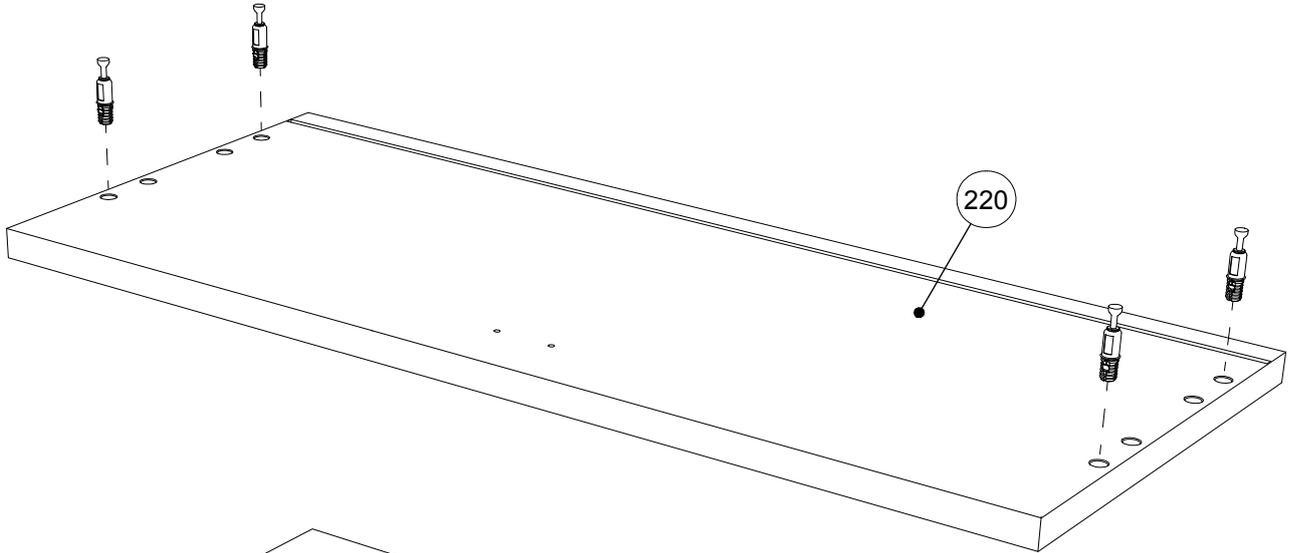
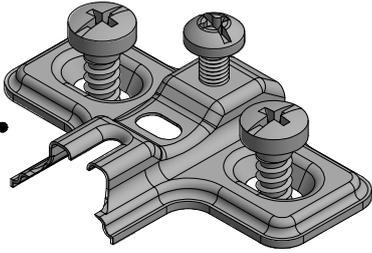

220

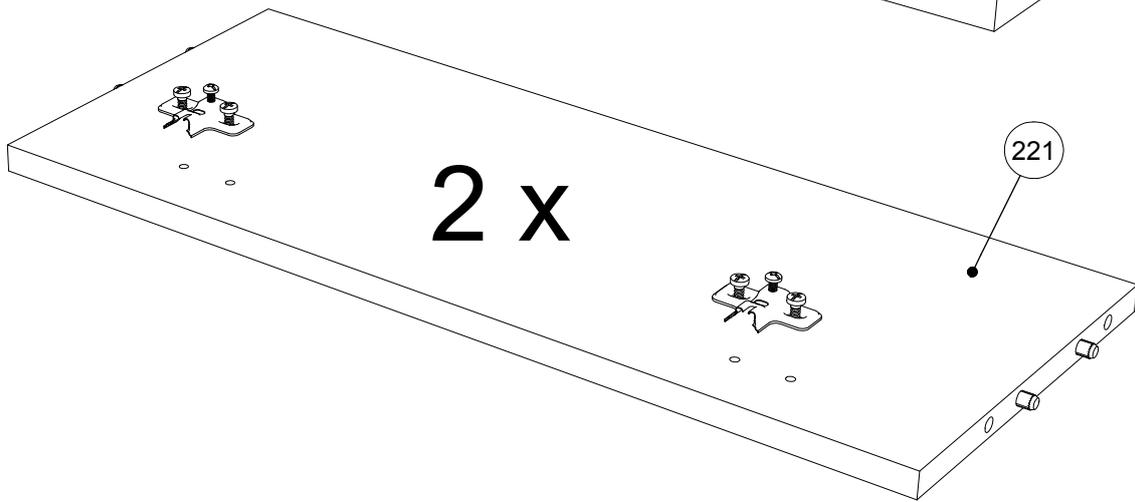

221

2 x

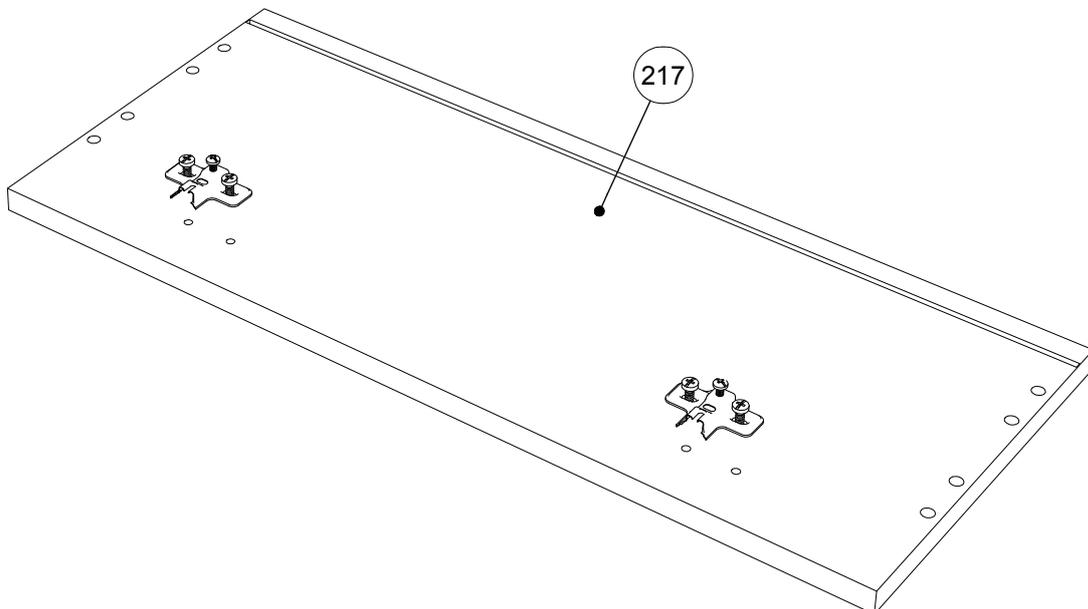

217

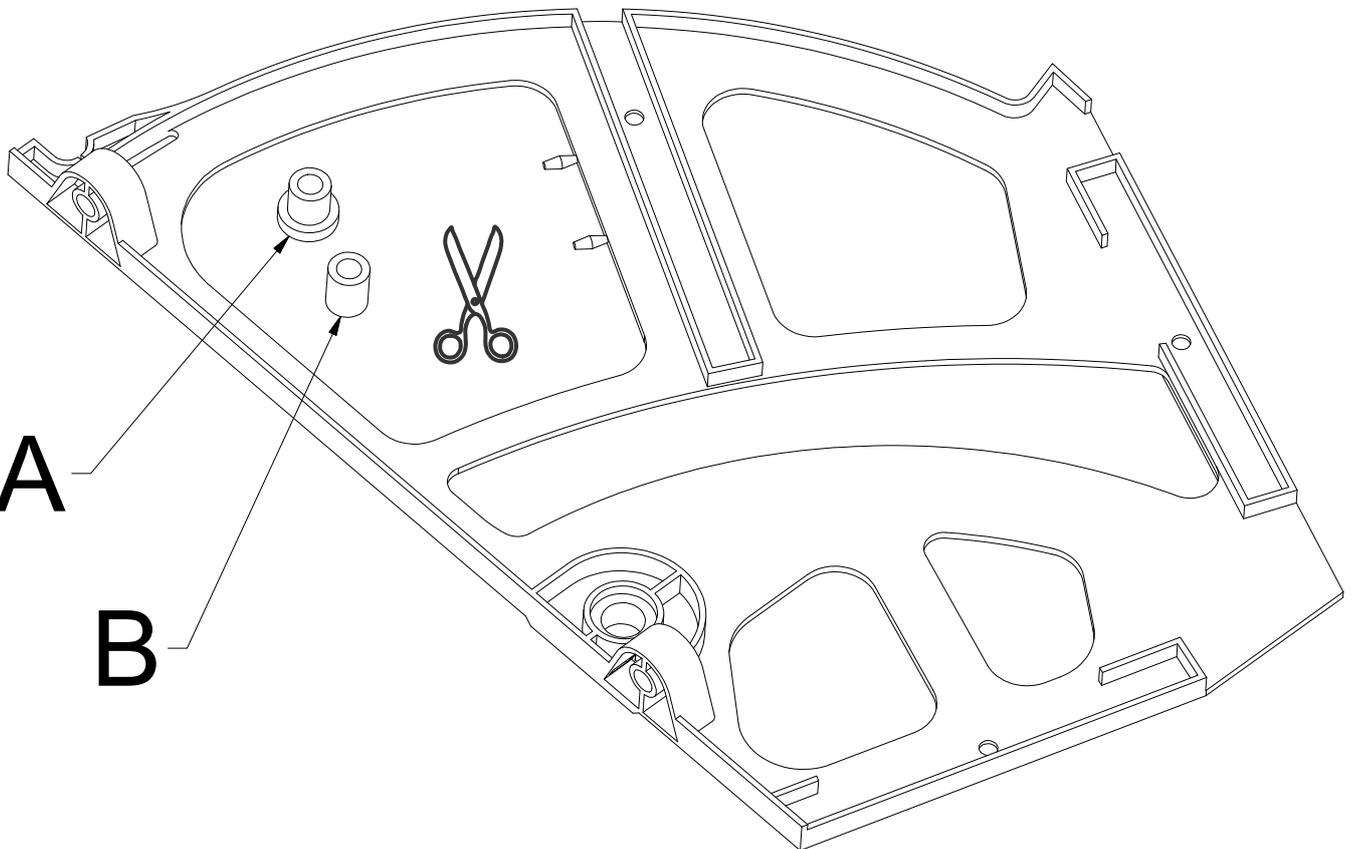
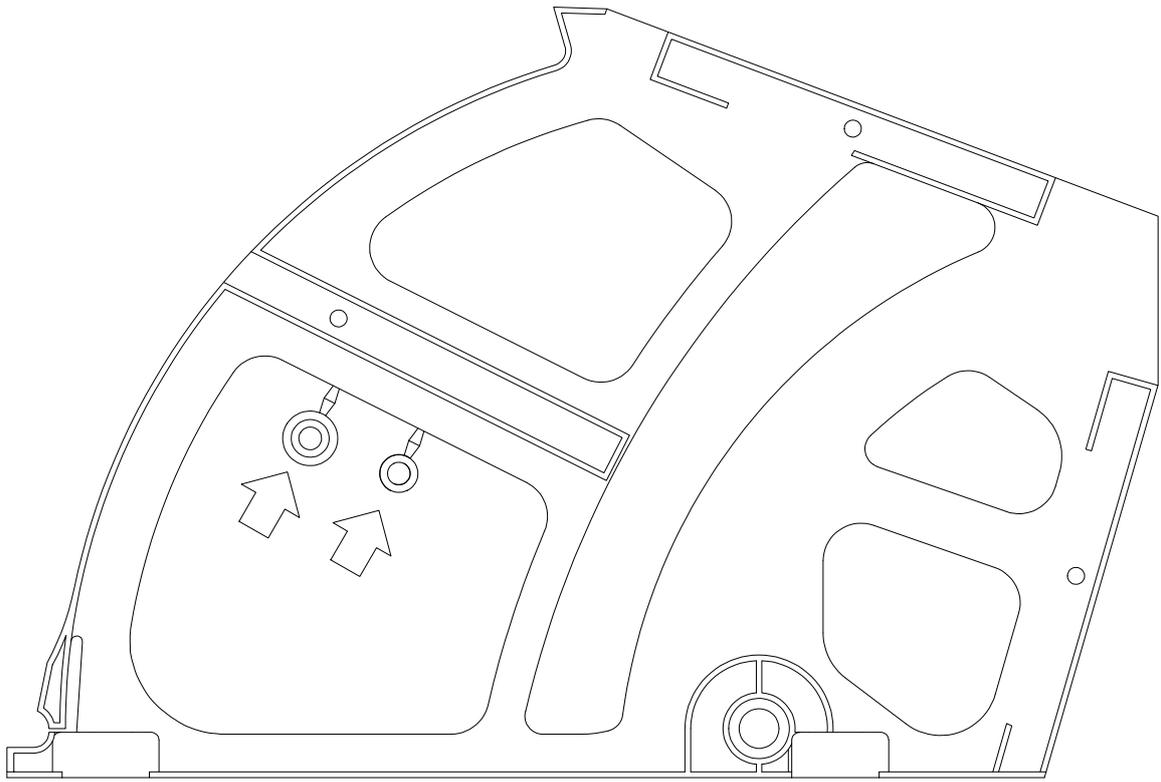

8 x SPL001



8 x FE9602

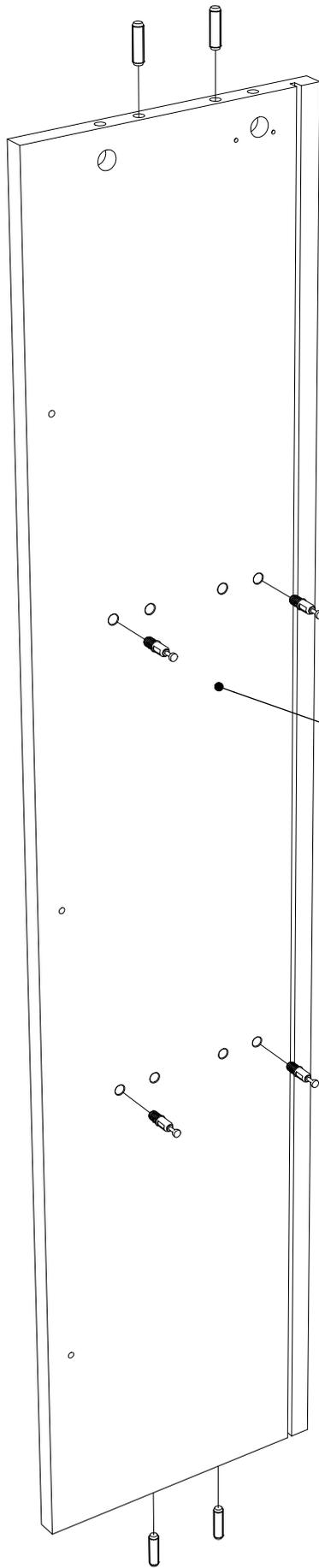

227

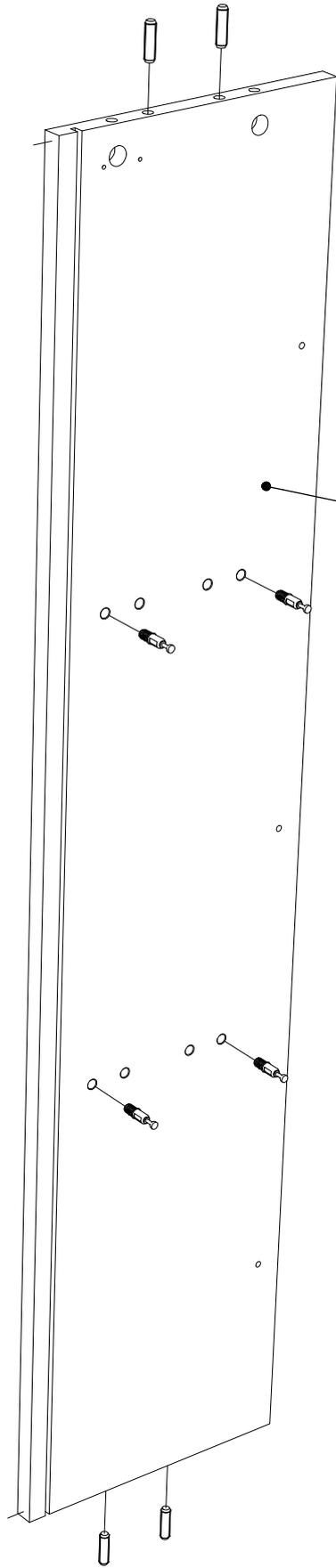

228

8 x FE9604

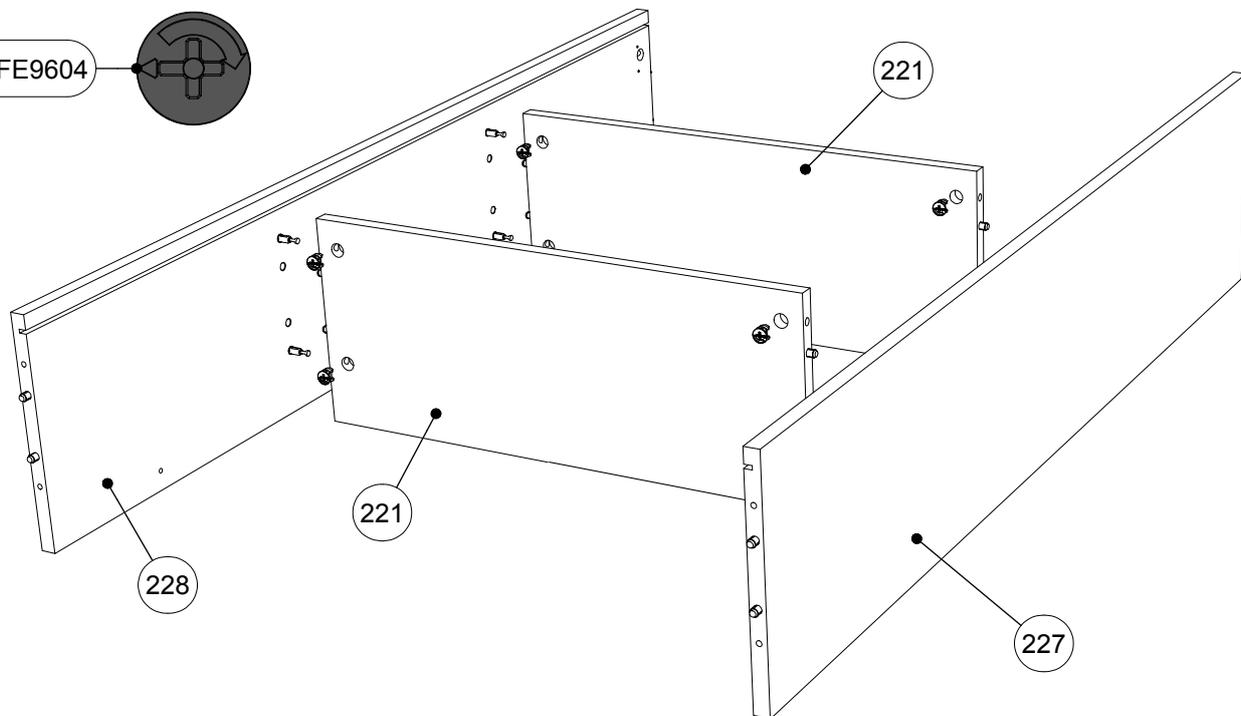
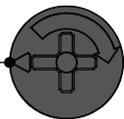

220

FE9798

4 x FE9604

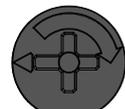

2 x FE9798

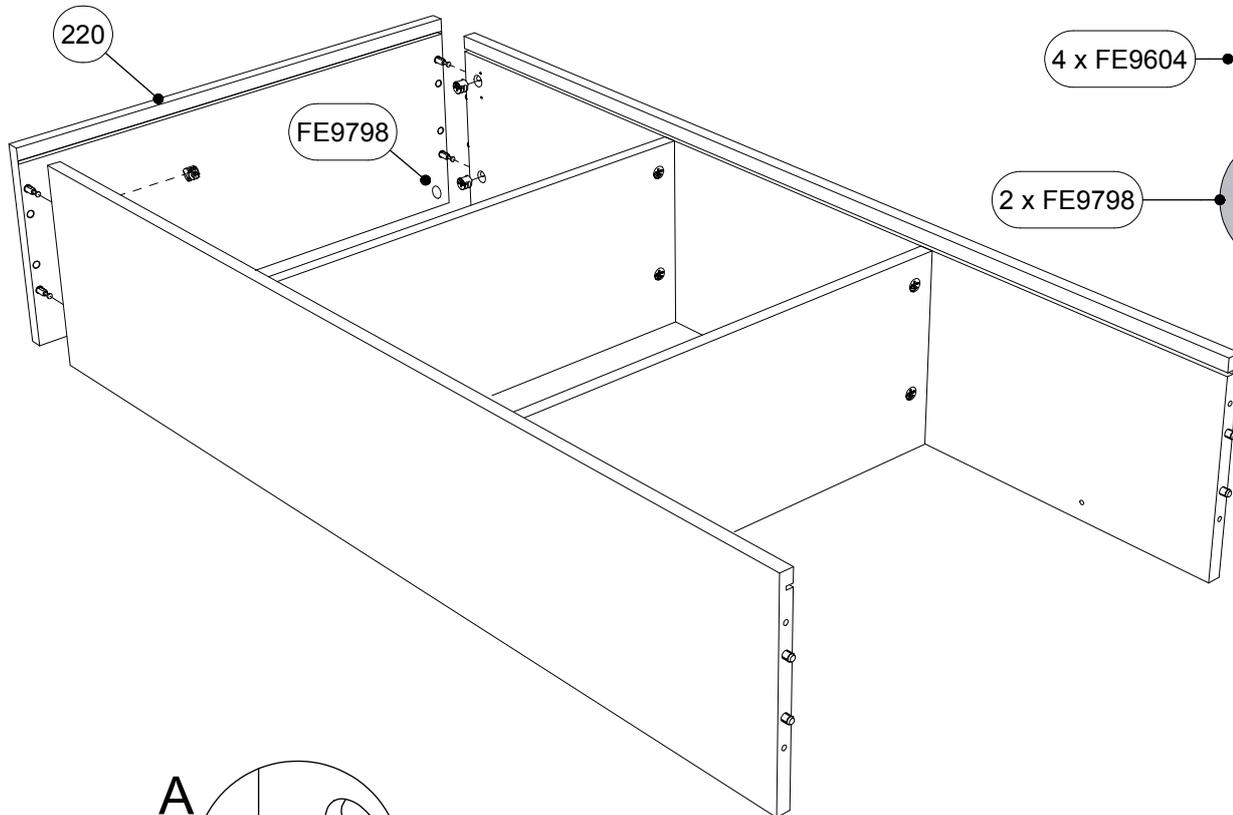
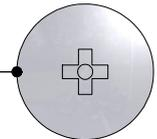

A

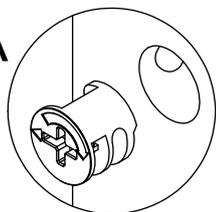

B

180°

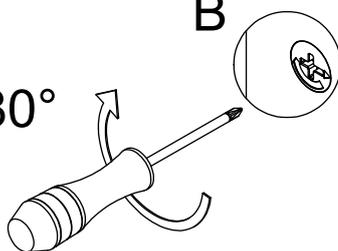

C

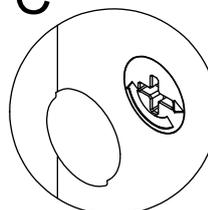

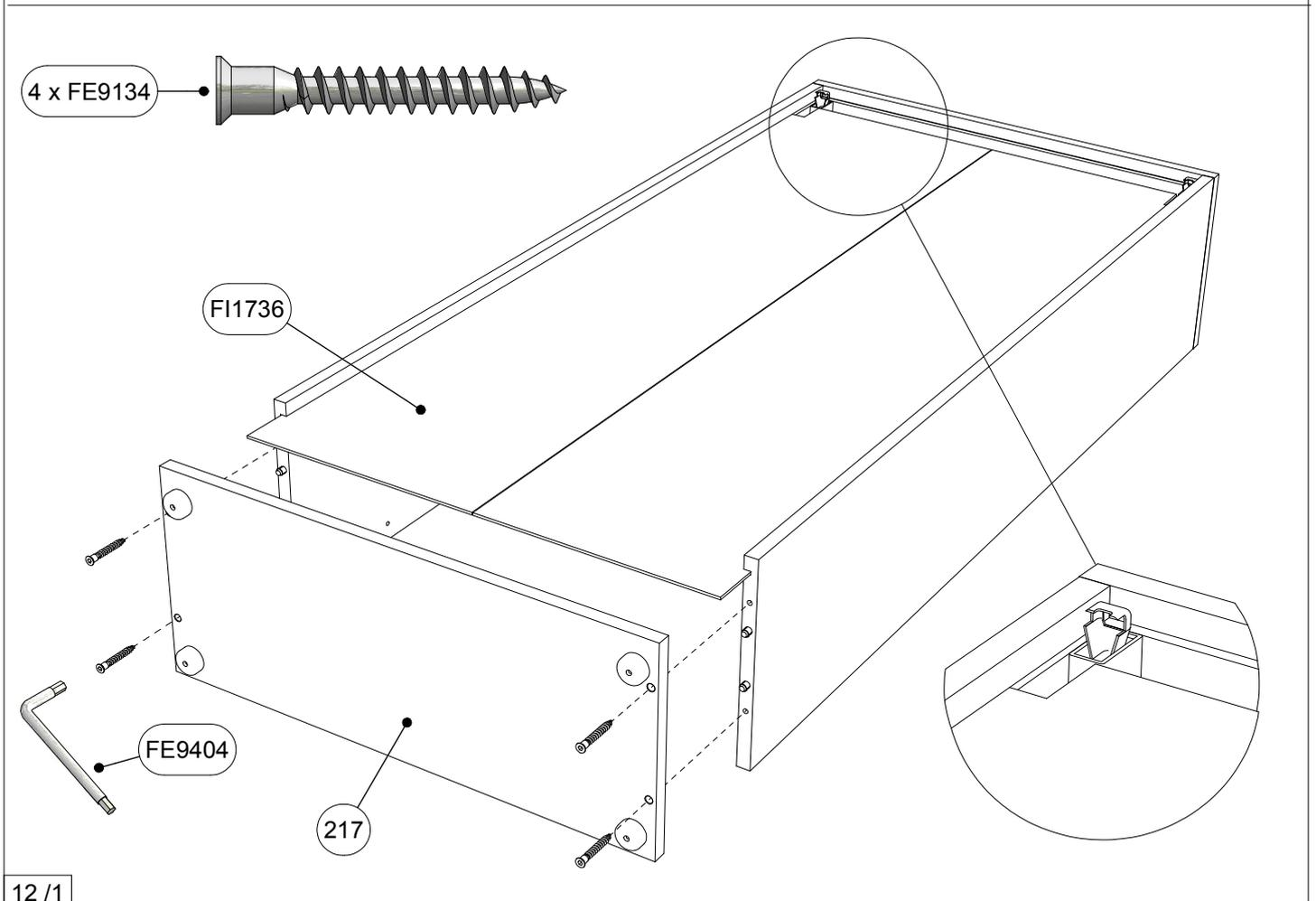
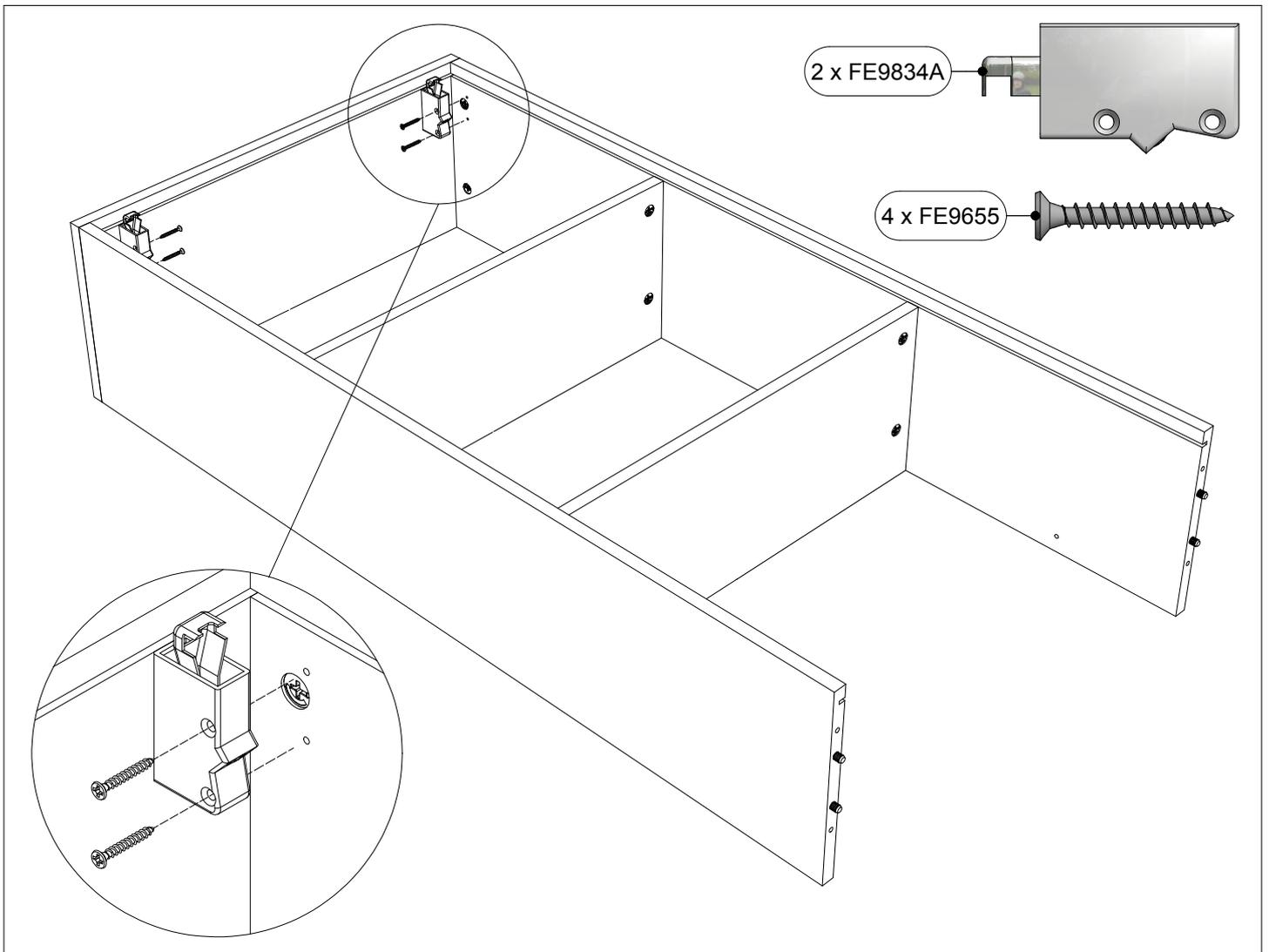

8 x FE9208



A=B

8 x FE9205

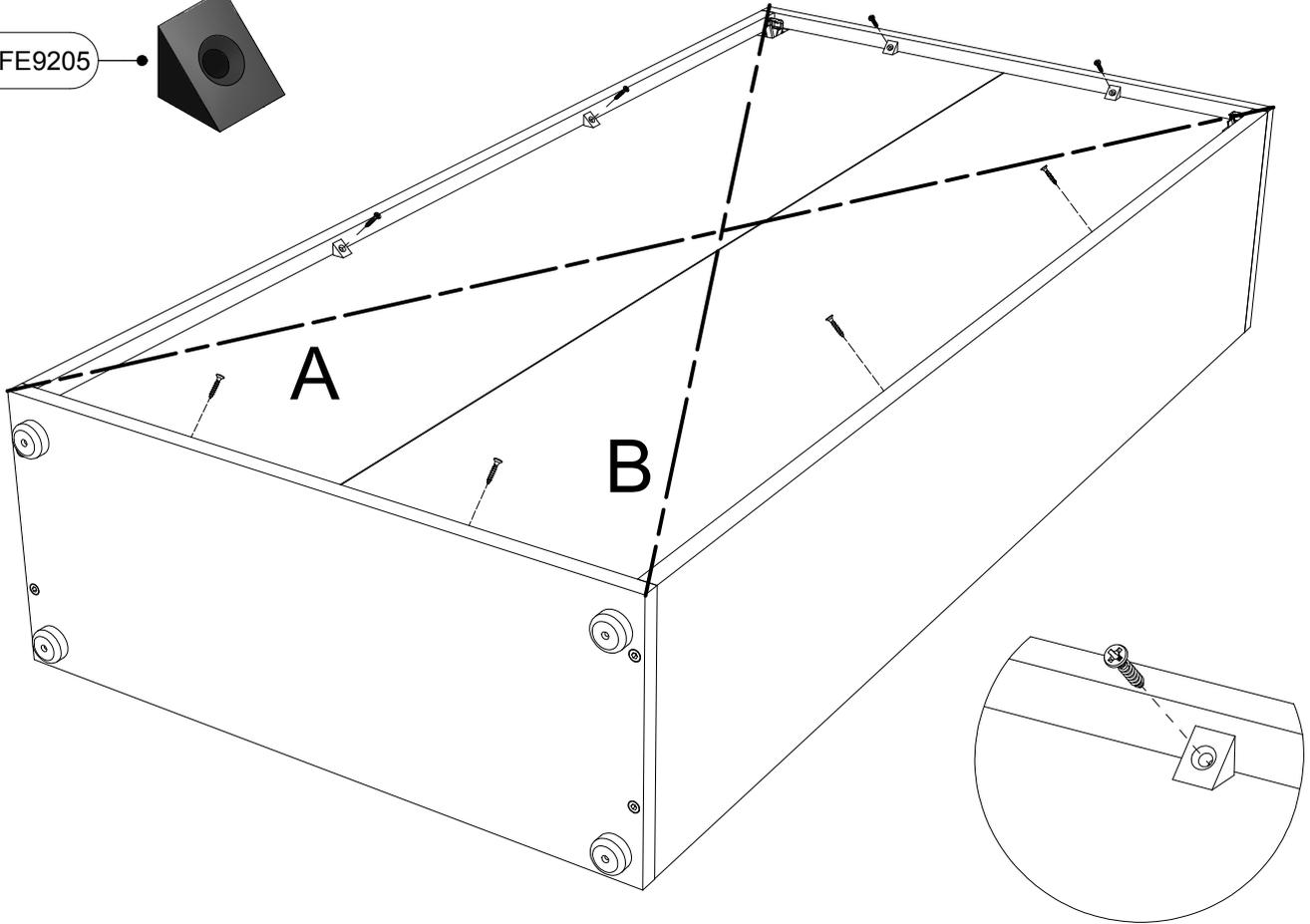

55 cm

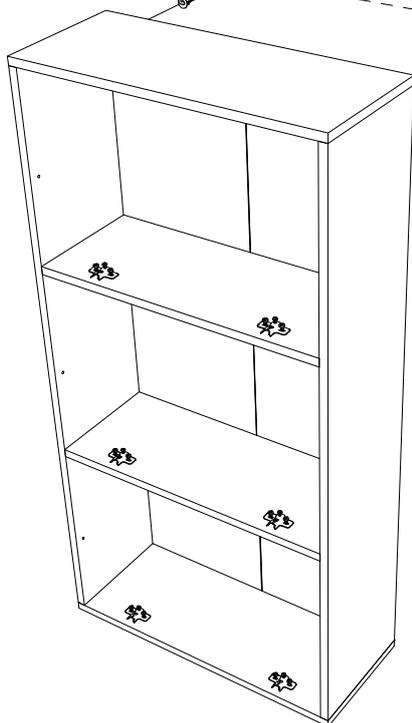

2 x FE9769

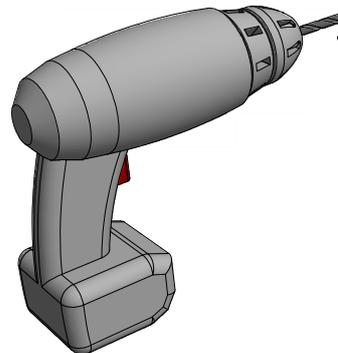
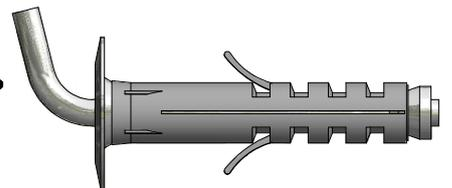

Ø 8



6 x ACE108

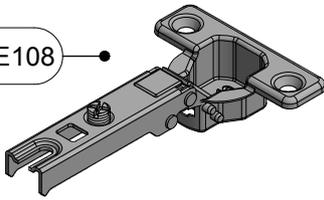

12 x FE9403



222

223

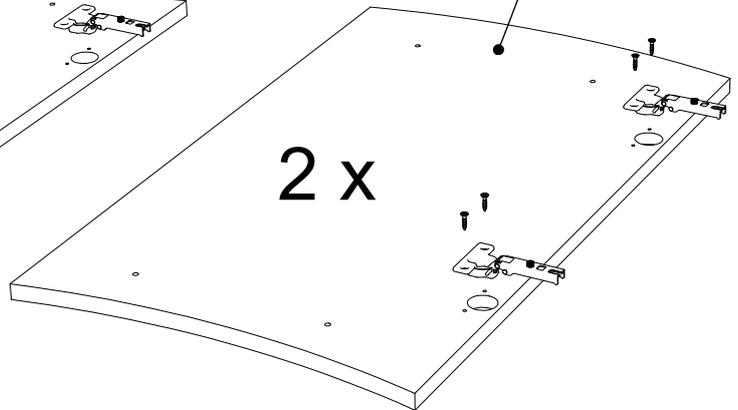
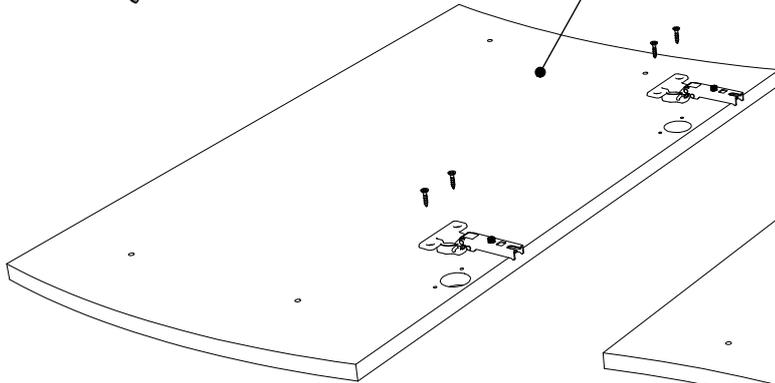

2 x

12 x FE9749



12 x FE2312

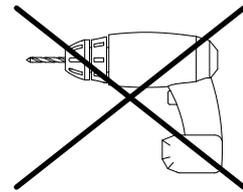

FE9749



FE9749

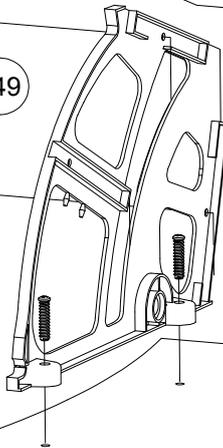

226

226

FE9749

FE9749

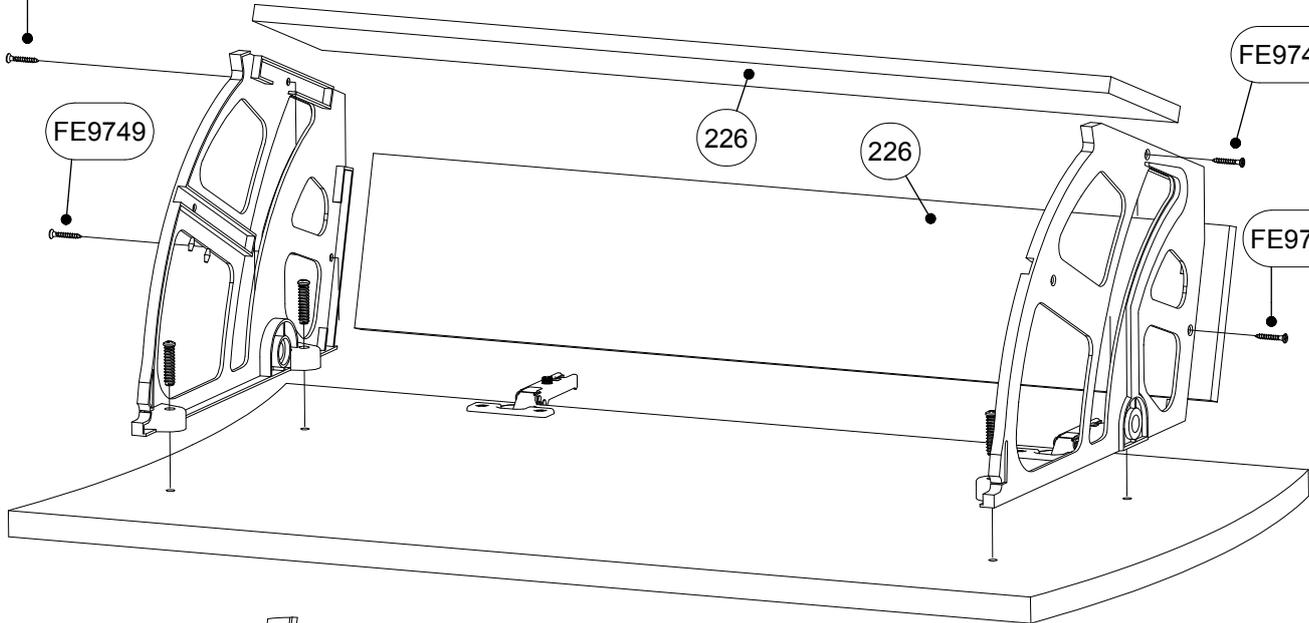

FE2312

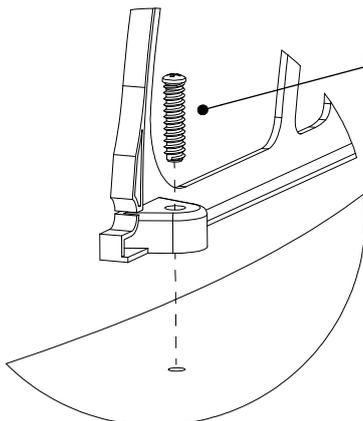

3 x

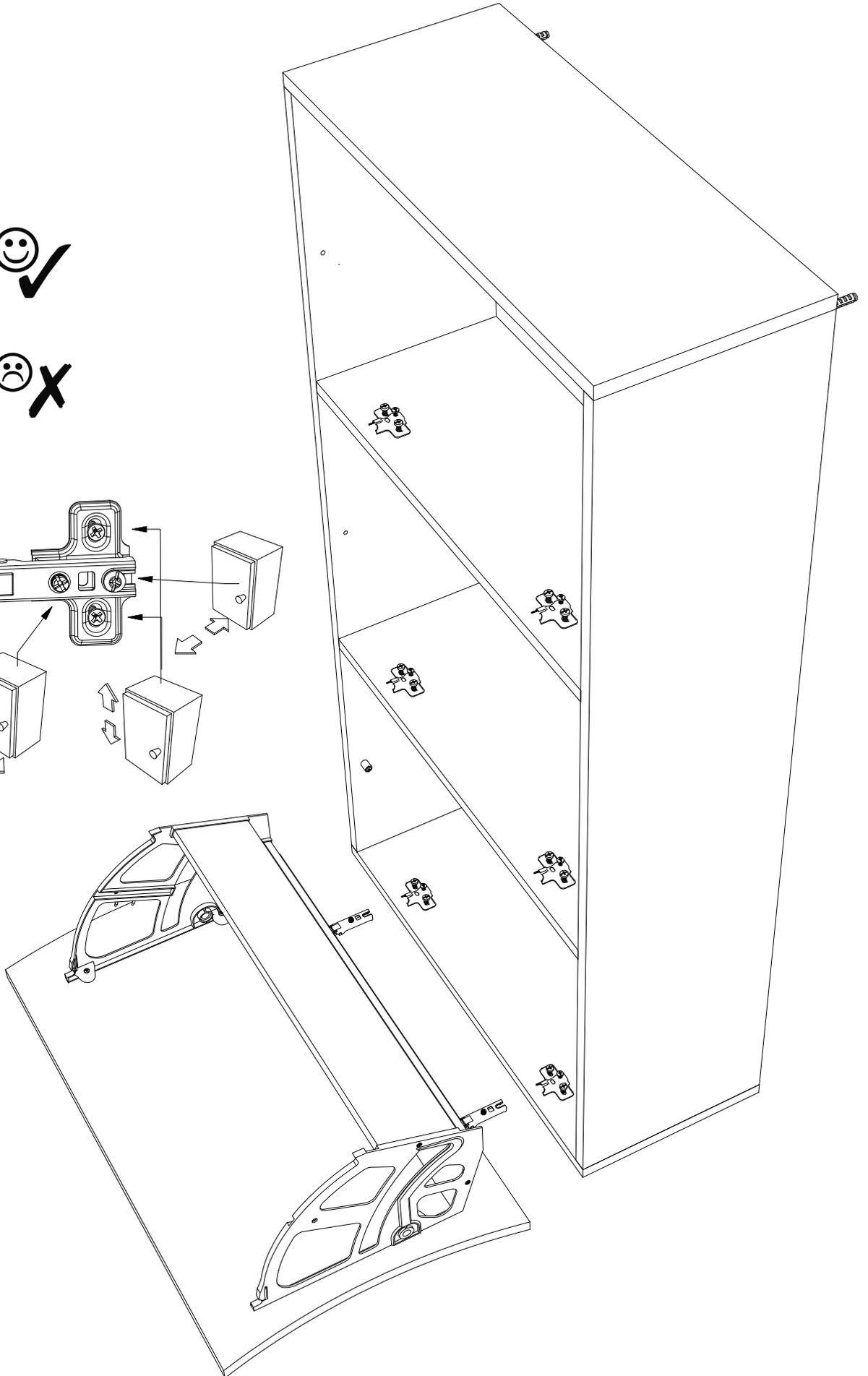
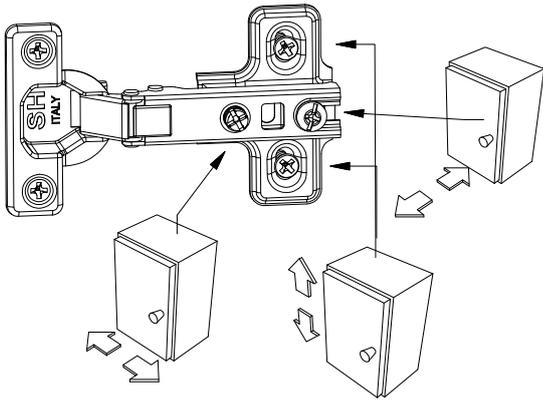
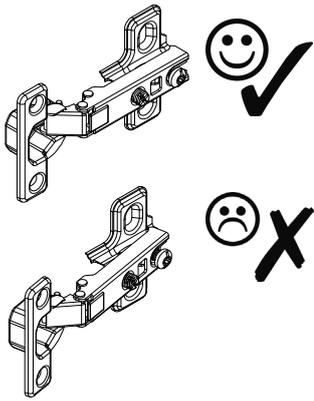

6 x FE2312



6 x B

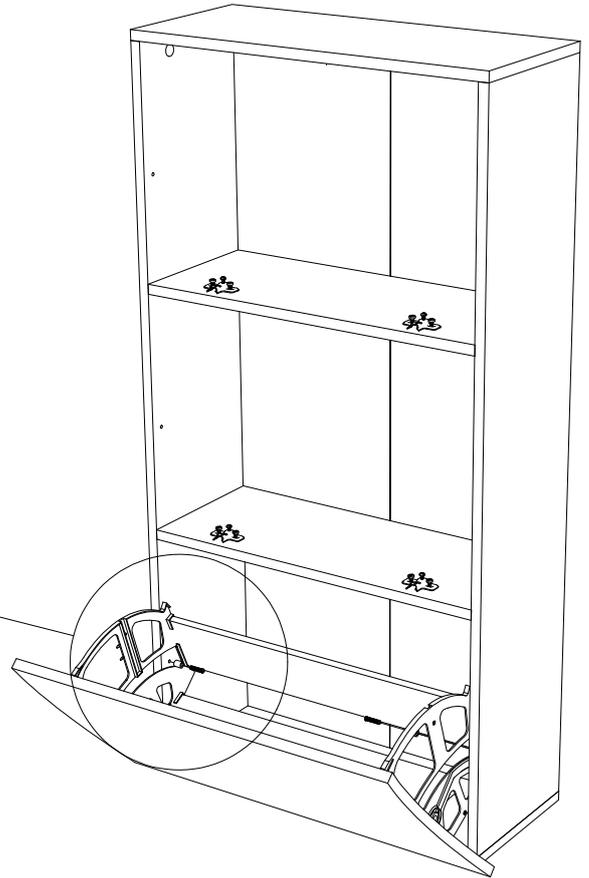
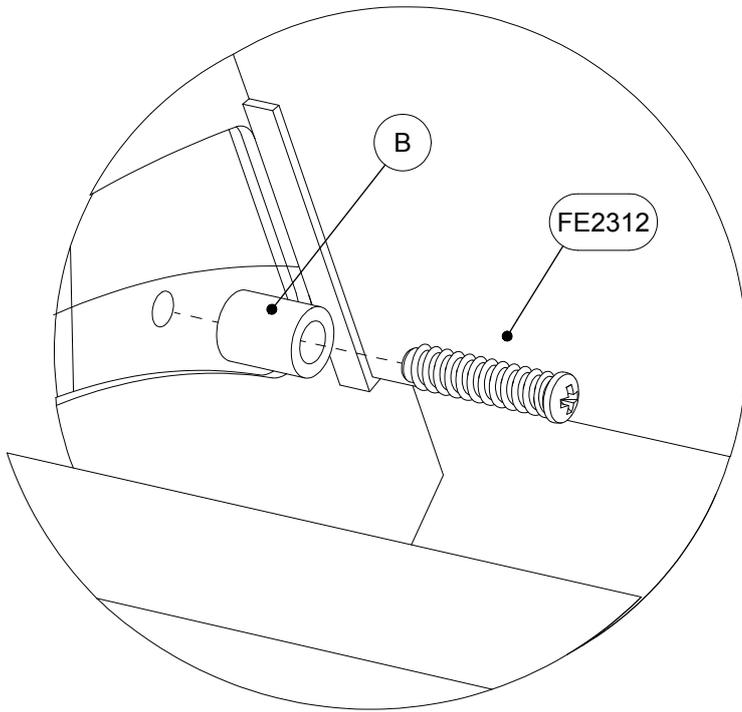

6 x FE9749

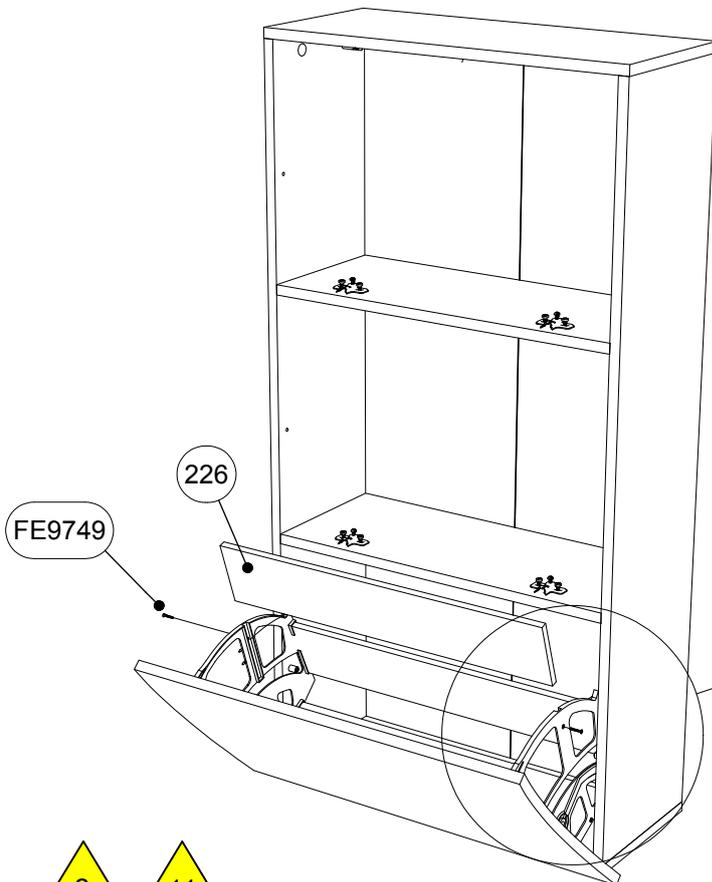
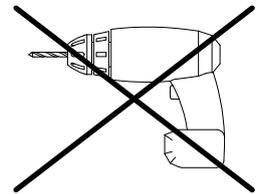

FE9749

226

FE9749



DE Pflegehinweise

Bitte nur mit einem Staubtuch oder leicht feuchtem Lappen reinigen. Keine scheuernden Putzmittel verwenden.
Schützen Sie Ihre Möbel generell vor Wasser (z.B. beim Wischen oder Blumen gießen). Die Feuchtigkeit kann in das Möbelstück eindringen und es beschädigen.

UK USA Care tips

Please only clean with a duster or a damp cloth. Do not use any abrasive cleaners.
In general, keep water away from your furniture (e.g. when mopping or watering plants). The moisture may penetrate the furniture and damage it.

NL Reinigingsnotities

Reinig alleen met een stofdoek of een lichtjes vochtige doek. Gebruik geen schurende poetsmiddelen.
Bescherm uw meubelen doorgaans tegen water (bijv. bij het dweilen of als u de bloemen water geeft). De vochtigheid kan in het meubelstuk dringen en het beschadigen

PL Wskazówki dotyczące pielęgnacji

Czyszczenie należy wykonać wyłącznie za pomocą ściereczki lub lekko nawilżonego ręcznika. Nie stosować środków czyszczących do szorowania.
Mebel należy chronić przed wodą (np. podczas czyszczenia lub podlewania kwiatków). Wilgoć może wnikać w mebel i uszkodzić go.

RU Обслуживание

Очищайте от пыли тряпкой или слегка влажной ветошью. Не допускается применение чистящих средств, не предназначенных для ухода за мебелью.
Предохраняйте мебель от попадания воды (например, при вытирании или поливке цветов). Не допускайте попадания влаги на мебель, чтобы предотвратить ее повреждение.

RO Indicații de întreținere

Vă rugăm să utilizați la curățare exclusiv o cârpă de șters praful sau o cârpă ușor umezită. Nu utilizați substa
Protejați întotdeauna mobilierul contra apei (de exemplu la stergere sau la udarea florilor). Mobilierul poate fi afectat expus umidității și se poate deteriora. Nu utilizați produse abrazive.

ES Alertas de mantenimiento

Limpe sólo con un paño húmedo, no utilice disolventes.
Proteja sus muebles de contacto con el agua. La infiltración de agua podría arruinar los muebles.

TR Bakım

Lütfen sadece bir toz bezle veya hafif nemli yumuşak bir bezle siliniz. Aşındırıcı temizlik malzemeleri kullanmayınız.
Genelde mobilyalarınızı sudan koruyunuz (örneğin, yerleri paspaslarken veya çiçekleri sularken). Nem, mobilya parçasına nüfuz edebilir ve zarar verebilir.

IT Avvisi di manutenzione

Pulire solamente con un panno umido, non utilizzare solventi.
Proteggere i mobili dal contatto con acqua. L'infiltrazione dell'acqua potrebbe rovinare il mobile.

FR Conseil d'entretien

Nettoyer avec un plumeau ou un chiffon humide. Ne pas utiliser de dissolvants.
En général, garder l'eau loin de vos meubles (par exemple lors de lavages, ou bien pour l'arrosage des plantes). L'humidité peut pénétrer les meubles et les endommager.

CZ Ošetřování

Čistěte prosím jen prachovkou nebo lehce navlhčeným hadrem. Nepoužívejte drhnoucí čisticí prostředky.
Chraňte váš nábytek před vodou (např. při utírání prachu nebo zalévání květin). Vlhkost může do nábytku proniknout a poškodit ho.

SK Ošetrovanie

Na čistenie používajte len prachovku alebo zľahka navlhčenú utierku. Nepoužívajte žiadne drhnúce čistiace prostriedky.
Chráňte váš nábytok celkovo pred vodou (napr. pri utieraní alebo polievaní kvetín). Vlhkosť môže vniknúť do nábytku a poškodiť ho.

HU Ápolási tanácsok

Kérjük, csak portörő kendővel vagy enyhén nedves ronggyal tisztítsa. Ne használjon dörzshatású tisztítószert.
Védje a bútort a víz ellen (pl. a letörlések során, ill. a növények öntözésekor). A nedvesség behatolhat a bútortá és azt tönkre teheti.

PT Alertas de manutenção

Limpe apenas com um pano úmido, não use solventes.
Proteja sua mobília de contacto com a água. A infiltração de água pode arruinar o mobiliário.