

Discus Mini Sconce

Installation Guide

M . M

Included for installation:

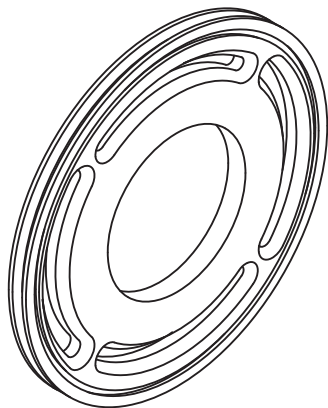

Mounting Plate

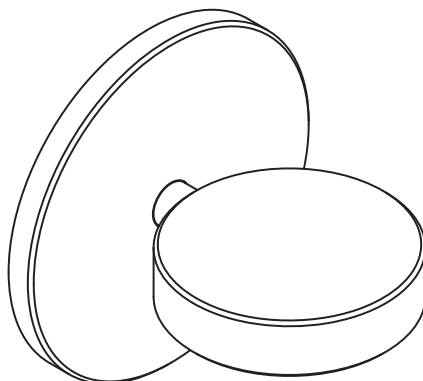

Sconce Assembly

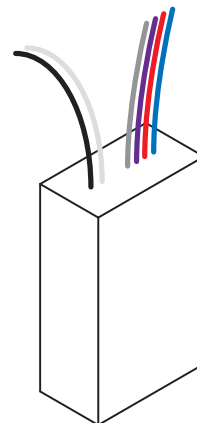

Driver

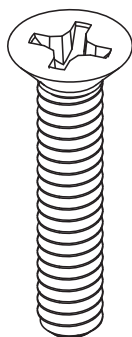

2x 10-24 Screw (outdoor installation)

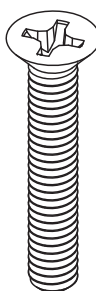

2x 8-32 Screw (junction box installation)

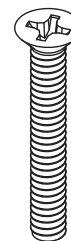

2x 6-32 Screw (switch box installation)



Hex wrench

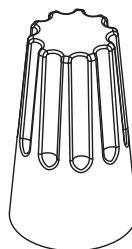

5x Wire Nuts

Discus Mini Sconce Installation Guide

M . M

Step 1.

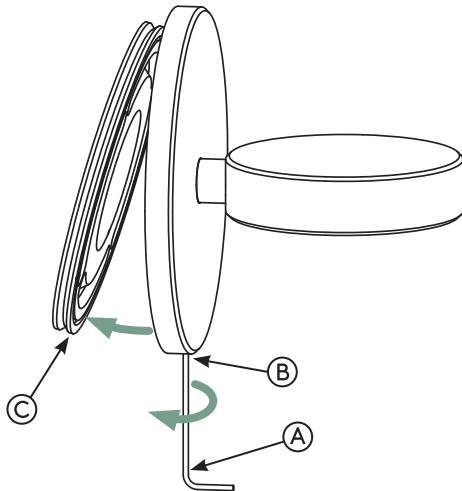

1. **Caution: Turn off power at the circuit breaker before beginning installation. Matter Made recommends the Discus Mini Sconce be installed by a qualified electrician.**

Using the included hex wrench (A), loosen the set screw (B) at the bottom of the fixture until the mounting plate (C) can be removed.

Step 2.

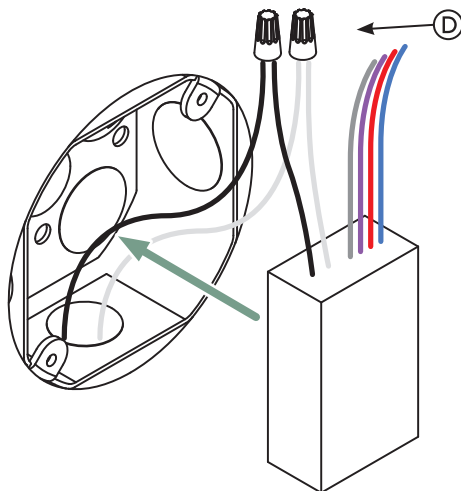

2. Using the supplied wire nuts (D), connect the live and neutral wires from the junction box to the live (black) and neutral (white) wires of the driver. Tuck the driver and the black, white, grey, and purple wires inside the junction box.

If you are using 0-10v dimming, connect the grey and purple wires of the driver to the corresponding wires connected to the dimmer. If 0-10v dimming is not used, cap the grey and purple wires separately with wire nuts or electrical tape.

Step 3.

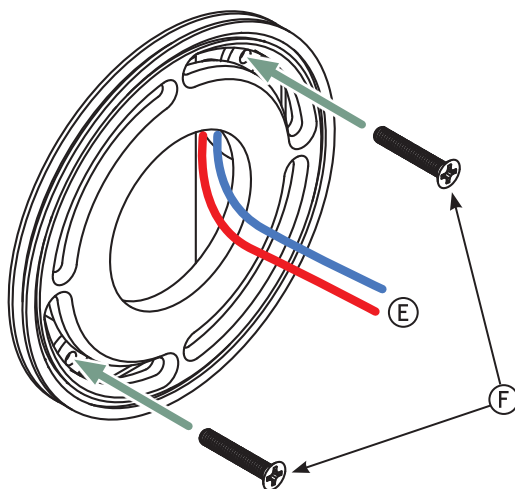

3. Feed the red and blue outlet wires (E) through the center hole of the mounting plate. Using a Philips screwdriver and the supplied screws (F), attach the mounting plate to the junction box. Make sure the side with the black o-ring seal is facing out. Different screw sizes are provided for various installation types. For switch boxes, use 6-32 screws. For octagonal junction boxes, use 8-32 screws. For weatherproof junction boxes, use 10-24 screws.

For outdoor installations, the mounting plate must be sealed to the junction box by either the gasket provided with your junction box or a bead of weatherproof sealant.

Discus Mini Sconce

Installation Guide

M . M

Step 4.

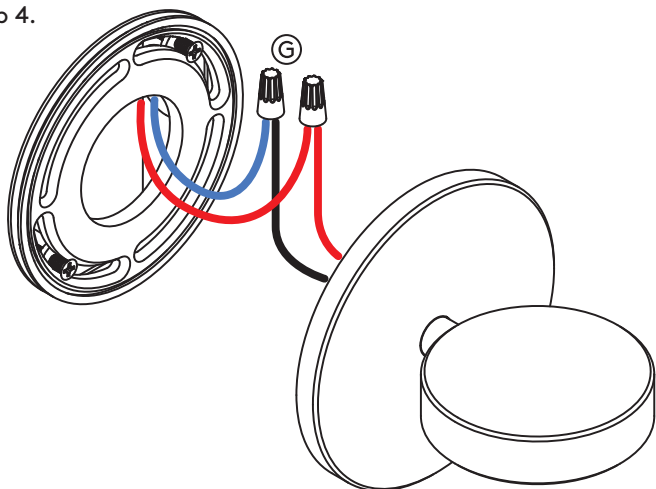

4. Using the provide wire nuts (G), connect the red and blue output wires from the driver to the red and black wires of the sconce assembly. Carefully tuck the wires and wire nuts through the center hole of the mounting plate into the junction box.

Step 5.

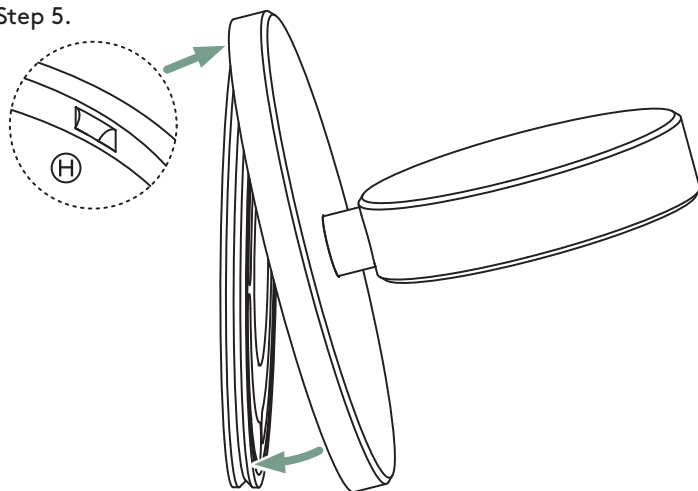

5. Locate the mounting tab (H) on the inside lip of the sconce assembly. Fit the sconce assembly over the mounting plate at an angle. Insert the mounting tab into the v-groove on the mounting plate first, then pivot the sconce assembly over the mounting plate.

Step 6.

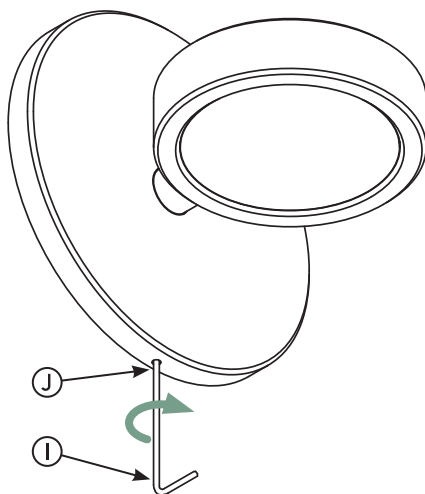

6. Using the included hex wrench (I), tighten the set screw on the bottom of the sconce assembly (J) until the fixture is secured.

Discus Mini Sconce

Installation Guide

M . M

Step 7.

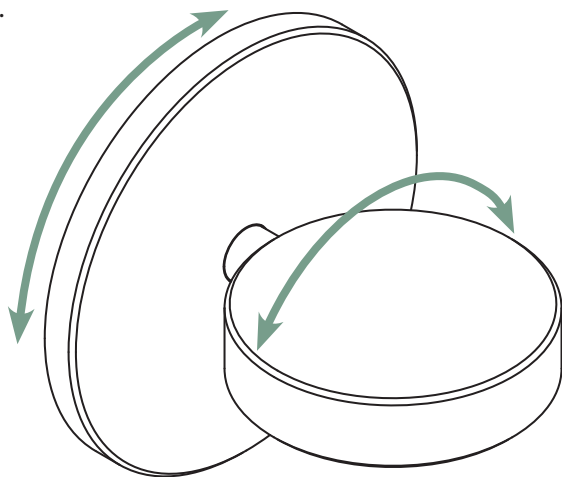

7. The head of the Discus Mini Sconce rotates 340° and includes a stop to prevent over-rotation. The stop location can be repositioned by loosening the set screw on the sconce assembly and rotating the sconce assembly around the mounting plate. Re-tighten the set screw after the fixture has been repositioned.

Turn on the power at the circuit breaker and test switch and dimming function.

Installation of the Discus Mini Sconce is now complete. Enjoy!