



TR800 play

Demarcation / Railing

Heras Tangorail is a self-raking railing system, with flexible panels that follow contours of the ground to provide optimum site safety and security.

The TR800 play is built from vertical tubular bars with horizontal rails. Manufactured to RoSPA guidelines for safe systems with no head, neck or finger traps.

TR800 play is available in heights from 900 to 1800 mm and is supplied with CHS (circular hollow section) posts.

The panels are attached to the posts using a unique post lock fitting. The non-welded design allows speedy installation, and adjustments are easily made on site.

Tangorail's exclusive non-welded design enables the panels to be assembled after coating; this means each panel component can be supplied in various colour combinations to brighten and suit all perimeters.

Suitable for schools and playgrounds.

- **Added safety – no gaps under fence and no risk of trapping head, neck or fingers**
- **Self-raking – no stepped panels and fewer posts**
- **Dirt-resistant smooth finish**
- **Eco-friendly - no welding and low zinc content**
- **Fast installation and manufacturing**

Experts in perimeter protection

Drawings

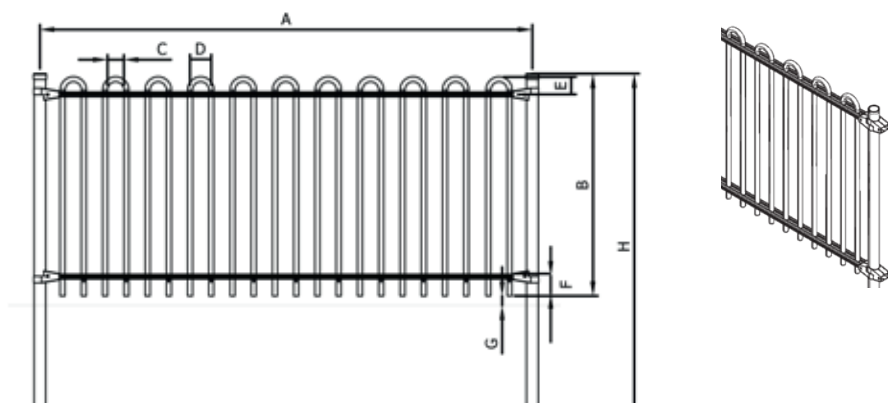

Technical specifications (dimensions in mm)

Type	Post centre-to-centre (A)*	Panel height (B)	C	D	E	F	G	Post height (H)	Dig in depth (J)
TR800 90	2565	850	85	110	90	75	50	1400	480
TR800 100	2565	950	85	110	90	75	50	1500	480
TR800 120	2565	1150	85	110	90	75	50	1750	530
TR800 150	2565	1450	85	110	90	75	50	2000	480
TR800 180	2565	1750	85	110	90	100	50	2400	530

* Max rake of a standard panel = 500 mm

Adjustment of post centres will be required to suit any intermediary rakes.

Material	Steel
Colour	RAL 6005 (moss green) RAL 9005 (jet black) Multicolour (optional)
Finish	Pre-galvanized and coated
Vertical bar diameter	26 mm
Vertical bar centre-to-centre	110 mm
Top and bottom rail dimensions	50 x 52 mm
Post profile	60 x 60 mm
Post centre-to-centre	2565 mm
Fixation vertical bars in railing	Spring loaded pin
Bows per panel	11
Post type (profile)	CHS
Number of fixings per post	2

Certificates

- Powder coating according to EN 13438 : 2005
- Steel used at grade DX51, galvanised to Z275
- Sheet steel hot dip coated as per EN 10346
- BS EN1176 – 1 RoSPA safety guidelines

Ordering information

Contact your local Heras office for precise ordering details.

Suggested accessories / products

- Quantum self-closing gate
- Pedestrian gate (single and double)
- Vehicle access swing gate