

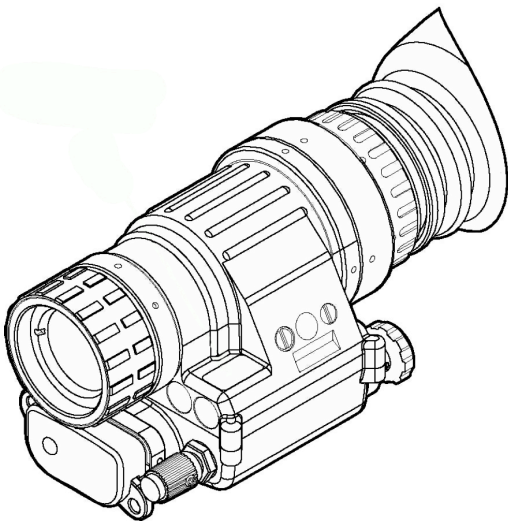

ACTinBlack Europe S.à r.l.

PVS-14
Monocular Night Vision Device



OPERATOR MANUAL

Inside Cover

OPERATOR MANUAL

PVS-14

Monocular Night Vision Device

ACTinBlack Europe S.à r.l.
Rue de l'Industrie,
L-3895 Foetz,
Grand Duchy of
Luxembourg

+352-20 30 10 30
info@actinblack.com
www.actinblack.com

This page intentionally left blank.

ADVISORY OVERVIEW

The following description categorizes the level of risk associated with each cautionary statement displayed throughout the manual.

WARNING

HIGHLIGHTS AN OPERATION OR PROCEDURE WHICH, IF NOT STRICTLY OBSERVED, COULD RESULT IN INJURY TO OR DEATH OF PERSONNEL.

CAUTION

HIGHLIGHTS AN OPERATION OR PROCEDURE WHICH, IF NOT STRICTLY OBSERVED, COULD RESULT IN DAMAGE TO OR DESTRUCTION OF EQUIPMENT OR LOSS OF MISSION EFFECTIVENESS.

NOTE

HIGHLIGHTS AN ESSENTIAL OPERATION, PROCEDURE, CONDITION OR STATEMENT.

This page intentionally left blank.

TABLE OF CONTENTS

Advisory Overview	6
Table of Contents	8
List of Figures	10
List of Tables	11
CHAPTER 1: GENERAL INFORMATION	12
1.1 Introduction	12
1.2 Equipment Description	12
1.3 Standard Kit Parts List	13
1.4 Standard Kit Parts Illustration	14
1.5 Optional Items List	15
1.6 Optional Items Illustration	16
1.7 System Performance and Data	17
CHAPTER 2: PREPARATION FOR USE	20
2.1 Introduction	20
2.2 Battery Precautions	20
2.3 Battery Installation	22
2.4 Eyecup Installation	22
2.5 Demist Shield Installation	23
2.6 Sacrificial Window Installation	23
2.7 Head/Helmet Mount Installation	24
2.8 Installation of Weapon Mount (Optional)	26

TABLE OF CONTENTS (CONT.)

CHAPTER 3: OPERATING INSTRUCTIONS	30
3.1 Introduction	30
3.2 Controls and Indicators	30
3.3 Hand-held Operation	33
3.4 Head Mounted Operation	34
3.5 Operations with IR Source	37
3.6 Using the Gain Control	37
3.7 Operation in Conditions of Blowing Dust or Sand	38
3.8 Operation in Rainy or Humid Conditions	39
3.9 Operation in Salt Water Areas	39
3.10 Shutting Down the Unit	39
3.11 Preparation for Storage	39
CHAPTER 4: MAINTENANCE INSTRUCTIONS	42
4.1 Introduction	42
4.2 Deactivation	42
4.3 Battery Removal	42
4.4 Cleaning the PVS-14A	42
4.5 Cleaning the Optics	43
4.6 Checking for Damage and Corrosion	43
CHAPTER 5: TROUBLESHOOTING	44
5.1 Troubleshooting Procedures	44
APPENDIX A: SPARE AND REPAIR PARTS LIST	48
A.1 Introduction	48
A.2 Contact Information	48
APPENDIX b: WARRANTY INFORMATION	50

LIST OF FIGURES

1-1	Standard Kit Parts Illustration	13
1-2	Optional Parts Illustration	15
1-3	System Performance and Data	17
2-1	Standard Installations	22
2-2	Headmount Diagram	26
2-3	Head/Helmet Mount Adapter Installation	27
3-1	Controls and Indicators	31
3-2	Head Mounted Operation	36
3-3	Gain Control	38

LIST OF TABLES

1-1	Standard Kit Parts List	13
1-2	Optional Items List	15
1-3	System Performance and Data	16
3-1	Controls and Indicators	32
5-1	Troubleshooting	44

CHAPTER 1:

GENERAL INFORMATION

1.1 **Introduction:**

This manual provides operation and field level maintenance instructions for the PVS-14A. It also provides specifications and data on the performance of the monocular. To ensure the safety of the operator and the correct operation of the monocular it is recommended that this manual is read carefully in its entirety before any deployment or field application.

1.2 **Equipment Description:**

The PVS-14A is a self-contained night vision device that enables improved night vision using ambient light from the night sky. Typically, the moon, star and/or sky glow.

Optically, it is made up of an objective lens, image intensifier and eyepiece lens. The objective lens collects light reflected from the night scene by the moon, stars, or night sky, inverts the image and focuses that image on the image intensifier. The image intensifier converts the captured light into a visible image and reinverts the image which can then be viewed through the eyepiece lens.

In situations where there is no light at all the unit can be switched into the infrared (IR) mode. The PVS-14A is equipped with an IR flashlight enabling the unit to use this invisible light to operate.

The PVS-14A is designed for differences in the physical features of individuals. This allows for a wide range of operators to use the system safely and comfortably. Some of these design features are the power switch, eye relief

adjustment, diopter adjustment, gain control, and objective focus. Lightweight and versatile, the PVS-14A can be hand-held, head-mounted, helmet-mounted, camera/camcorder adapted or weapon mounted as a tactical night scope. The PVS-14A is the most widely fielded night vision system available.

1.3 Standard Kit Parts List:

The standard PVS-14A kit comes with the items listed in the following table.

Item	Description	qty.
1	Monocular Assembly	1
2	AA Alkaline Battery	2
3	Demist Shield	1
4	Shoulder Strap	1
5	Sacrificial Lens	1
6	Lens Tissue (packet)	1
7	Operator Manual	Digital
8	Soft Carrying Case	1
9	Weapon Mount	Option
10	Head/Helmet Mount Adapter	1
11	Headmount Assembly w/ Brow Pads	1

Table 1-1 Standard Kit Parts List

1.4 Standard Kit Parts Illustration:

The illustration below is provided for quick identification of the standard parts of the PVS-14A kit.

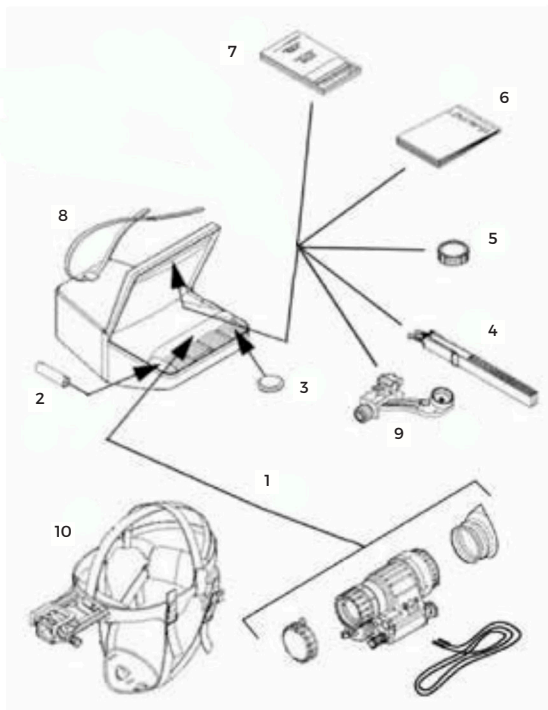

Figure 1-1 Standard Kit Parts Illustration

1.5 **Optional Items List:**

The PVS-14A is compatible with the following optional items and accessories listed in the following table.

Item	Description
1	Shipping/Storage Case
2	Tethering Cord
3	PASGT Helmet Mount, Flip-Up
4	Magnetic Compass
5	5X Afocal Lens
6	3X Afocal Lens
7	Shuttered Eyeguard

Table 1-2 Optional Items List

1.6 Optional Items Illustration:

The illustration is provided as a visual key to optional items that can be used with the standard PVS-14A.

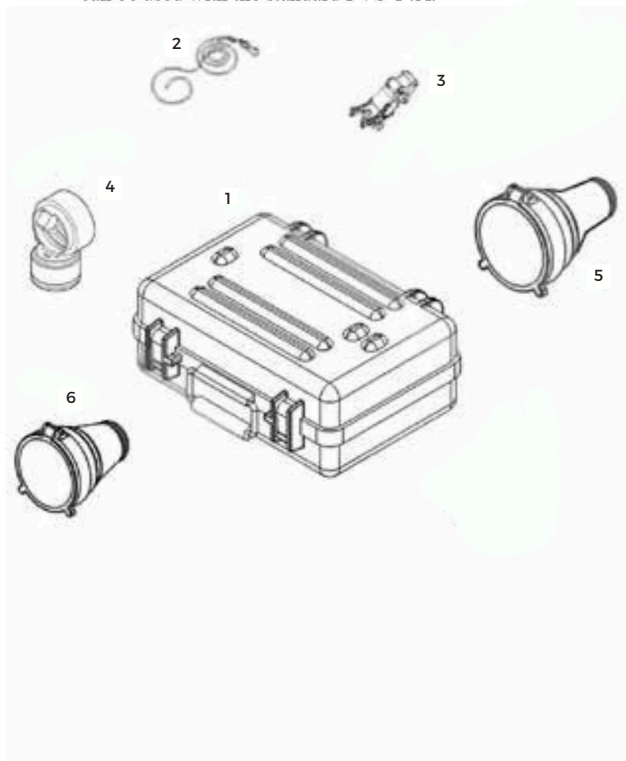

Figure 1-2 Optional Parts Illustration

1.7 System Performance and Data:

The chart below lists the technical specifications and data of the PVS-14A system. The data contained herein is subject to change without notice.

ITEM	LIMITS
Electrical Data	
Power Source	Battery (1.5V DC max.)
Battery Requirements	1 AA Alkaline or 1 AA Lithium L91
Battery Life (AA Alkaline)	40 hrs @ 21°C (70°F)
Battery Life (Lithium)	40 hrs @ 21°C (70°F)
Physical Data	
Soft Carrying Case Dimensions	17.8cm x 30.1cm x 7.6cm (7" x 12" x 3")
Monocular Dimensions	11.4cm x 5.0cm x 5.7cm
Monocular Weight, with battery	346g
Optical Data	
Magnification	1.0X
Field of View	40° (+/-2°)
Eyepiece of Focus	+2 to -6 diopters
Focus Range	25 cm (9.8") to infinity
Eye Relief	25 mm

Table 1-3 System Performance and Data

Objective Lens	f/1.2
Resolution	up to 1.3 cy/mR with 64 lp/mm tube
Environmental Data	
Operating Temperature	-51°C to 50°C
Storage Temperature	-51°C to 85°C
Illumination Required	Overcast starlight to moonlight
Immersion	5 meter for 30 minutes

Table 1-3 System Performance and Data, (cont.)

This page intentionally left blank.

CHAPTER 2: PREPARATION FOR USE

2.1 Introduction:

This section contains instructions for installing and attaching various components and accessories to the PVS-14A for operation under normal conditions.

2.2 Battery Precautions:

WARNING

DO NOT MIX ALKALINE AND LITHIUM BATTERIES. DO NOT MIX OLD AND NEW BATTERIES. DO NOT MIX BRANDS OF BATTERIES. DO NOT MIX DISPOSABLE AND RECHARGEABLE BATTERIES. FAILURE TO FOLLOW THESE INSTRUCTIONS COULD RESULT IN DEATH, INJURY OR IMPOSITION OF LONG- TERM HEALTH HAZARDS.

WARNING

INSPECT BATTERIES FOR BULGING PRIOR TO USE. IF THE BATTERY SHOWS SIGNS OF BULGING, DO NOT USE.

WARNING

DO NOT HEAT, PUNCTURE, DISASSEMBLE, SHORT CIRCUIT, INCINERATE, ATTEMPT TO RECHARGE OR OTHERWISE TAMPER WITH THE BATTERIES. TURN OFF THE PVS-14A IF THE BATTERY COMPARTMENT BECOMES UNDULY HOT.

**IF POSSIBLE, WAIT UNTIL THE
BATTERIES HAVE COOLED BEFORE
REMOVING THEM.**

WARNING

**DO NOT REPLACE BATTERIES IN A
POTENTIALLY EXPLOSIVE ATMOSPHERE.
CONTACT SPARKING MAY OCCUR
WHILE
INSTALLING OR REMOVING BATTERIES AND
CAUSE AN EXPLOSION. FAILURE TO
FOLLOW THESE INSTRUCTIONS COULD
RESULT IN DEATH, INJURY OR
IMPOSITION OF LONG- TERM HEALTH
HAZARDS.**

CAUTION

**OBEY THE BATTERY MANUFACTURER'S
DIRECTIONS FOR BATTERY DISPOSAL.**

2.3 Battery Installation:

Install one (1) AA battery as follows.

1. Remove the battery cap by turning it counter-clockwise.
2. Check to ensure the o-ring is present. If not, replace it.
3. Observe polarity as indicated on the outside of the battery compartment.
4. Insert battery into the battery compartment, plus (+) end first.
5. Replace battery cap by pushing and turning it clockwise. Tighten it firmly to ensure a watertight seal.

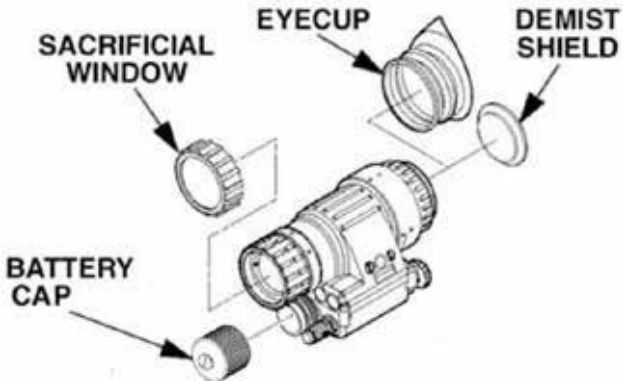

Figure 2-1 Standard Installations

2.4 Eyecup Installation:

Perform the following procedure to install eyecup onto the monocular.

1. Carefully press the eyecup over the end of the eyepiece lens.

2. Rotate the eyecup into proper viewing position. Adjust for best fit. The eyecup must seal around your eye and prevent the green glow from escaping.

2.5 Demist Shield Installation:

Perform the following procedures to install the demist shield on the eyepiece lens.

1. Carefully remove the eyecup.
2. Carefully press the demist shield onto the eyepiece. Be careful not to smudge the eyepiece lens or demist shield.
3. Replace the eyecup.

CAUTION

IF THE DEMIST SHIELD IS WIPED WHILE WET OR WITH WET LENS TISSUE, YOU WILL DAMAGE THE COATING.

NOTE

IF INCLEMENT OPERATING CONDITIONS ARE EXPECTED TO EXIST (E.G. SIGNIFICANT TEMPERATURE CHANGE AND HIGH HUMIDITY), INSTALL DEMIST SHIELD TO MINIMIZE EYEPIECE LENS FOG PRIOR TO EXECUTION OF MISSION.

2.6 Sacrificial Window Installation:

Perform the following procedure to install the sacrificial window onto the objective lens assembly.

CAUTION

IF ADVERSE OPERATING CONDITIONS (BLOWING DUST OR SAND) ARE EXPECTED TO EXIST, ATTACH THE SACRIFICIAL

**WINDOW TO PROTECT THE OBJECTIVE
LENS FROM SCRATCHES OR OTHER
DAMAGE.**

1. If the objective lens cap is in place, remove it.
2. Carefully push the sacrificial window onto the objective lens until it stops. Turn the sacrificial window clockwise until it snaps into place.

- 2.7 Headmount Adjustment and Installation (Optional):**
Perform the following procedure to adjust and install the headmount assembly.

CAUTION

**DO NOT PUT ON THE HEADMOUNT WHILE
THE MONOCULAR IS ATTACHED.**

1. Prior to donning the headmount, loosen the four ends of the chinstrap approximately two inches from the sliding bar buckles.
2. Firmly press the front and rear snaps in place.

NOTE

**IF THE HEADMOUNT IS TOO LOOSE,
REMOVE THE ATTACHED THIN BROWPAD
AND REPLACE WITH EITHER THE MEDIUM
OR THICK BROWPAD SUPPLIED WITH THE
HEADMOUNT.**

3. With both hands, grasp the neck pad and pull the harness over your head and the neck pad down to the back of your neck.

4. Holding the chin cup in position on chin, adjust both sides of the chinstrap until you feel light pressure against your chin. (DO NOT TIGHTEN.)
5. Maintain the position of the chin cup and remove any slack from the chinstrap. (DO NOT TIGHTEN.)
6. Ensure that the cross-strap is not twisted and remove slack by adjusting the vertical adjustment at the neck pad.
7. Adjust chinstrap and vertical adjustment until the chin cup and headband are in a comfortable but firm position.

NOTE

**AFTER INSTALLING THE
MONOCULAR, MINOR STRAP
ADJUSTMENTS MAY BE NECESSARY
TO ACHIEVE COMFORT.**

8. Install the head/helmet mount adapter.

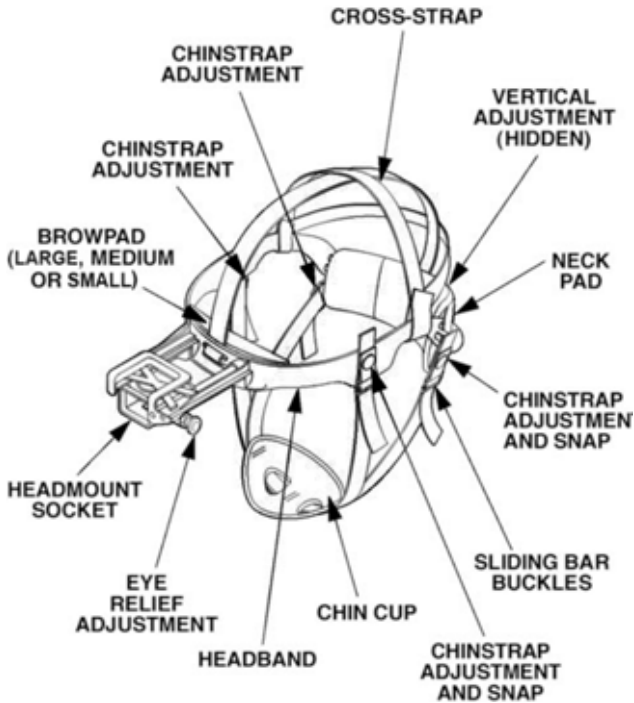

Figure 2-2 Headmount Diagram

2.8 Head/ Helmet Mount Installation:

Install the head/helmet mount adapter into the monocular by

following the procedure.

1. Align the thumbscrew with the threaded hole and tighten as shown in Figure 2-3.
2. Locate the alignment boss on the headmount/helmet mount adapter that fits into a groove on the monocular.
3. Make sure the boss on the adapter fits into the groove on the monocular.
4. Loosen the clamp knob and pivot the arm to the other side for PVS-14A use with the right eye.

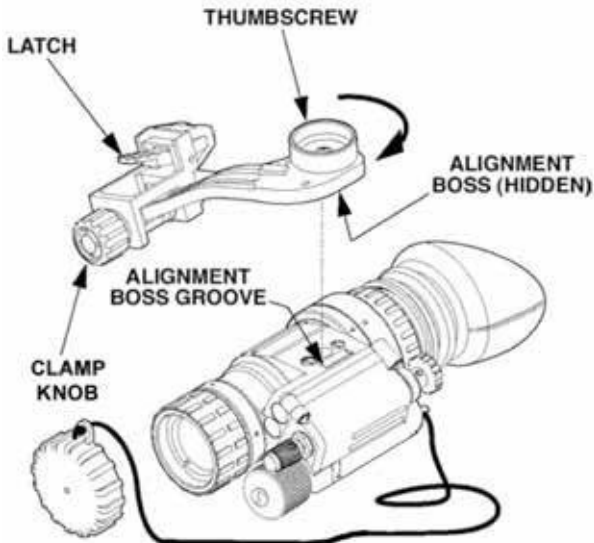

Figure 2-3 Head/Helmet Mount Adapter Installation

2-9 **Installation of Weapon Mount:**

Perform the following procedure to install the weapon mount.

CAUTION

THE PVS-14A IS NOT A WEAPON SIGHT, HOWEVER, IT CAN BE USED IN CONJUNCTION WITH A COLLIMATED DOT SIGHT OR LASER AIMING DEVICE.

NOTE

IT IS RECOMMENDED THAT THE EYECUP BE REPLACED WITH THE SHUTTERED EYEGUARD DURING WEAPON MOUNTED USE.

1. Orient the monocular and weapon mount as shown in Figure 2-4. Be sure to align the alignment boss on the weapon mount with the alignment groove in the monocular.
2. Screw in the thumbscrew to secure the monocular to the weapon mount.
3. Loosen the clamping knob on the weapon mount. Position the weapon mount with the monocular onto the weapon's mounting rail. Tighten by turning the clamping knob.

NOTE

A RATCHET IN THE WEAPON MOUNT PREVENTS OVER TIGHTENING OF THE CLAMP. TURN UNTIL THE KNOB CLICKS.

4. Check the position of the monocular by holding the weapon in the normal firing position. Adjust the fore/aft position of the monocular as necessary by loosening the clamping knob and repositioning the weapon mount on the weapon's mounting rail.

This page intentionally left blank.

CHAPTER 3: OPERATING INSTRUCTIONS

3.1 **Introduction:**

This chapter contains instructions for the safe operation of the PVS-14A under normal circumstances and environments.

3.2 **controls and Indicators:**

The PVS-14A is designed to adjust for different users and corrects for most differences in eyesight. The controls and indicators for the PVS-14A are shown in Figure 3-1 and are described in Table 3-1.

CAUTION

THE PVS-14A REQUIRES SOME AMBIENT (MOONLIGHT, STARLIGHT, OR ARTIFICIAL LIGHT, ETC.) TO OPERATE. THE LEVEL OF PERFORMANFE DEPENDS ON THE LEVEL OF LIGHT.

NIGHT LIGHT IS REDUCED BY PASSING CLOUD COVER, WHILE OPERATING UNDER TREES, IN BUILDING SHADOWS, ETC.

THE PVS-14A IS LESS EFFECTIVE VIEWING INTO SHADOWS AND OTHER DARKENED AREAS.

THE PVS-14A IS LESS EFFECTIVE THROUGH RAIN, FOG, SLEET, SNOW, SMOKE, AND OTHER REFLECTIVE MATERIAL.

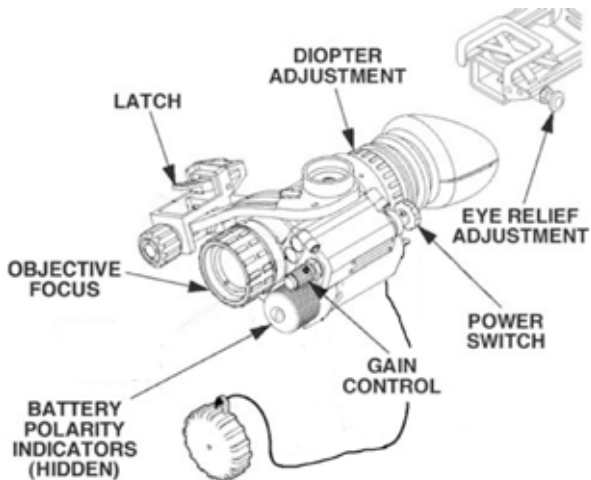

NOTE - LOW BATTERY INDICATOR AND IR SOURCE "ON" INDICATOR ARE VISIBLE IN EYEPIECE LENS

Figure 3-1 Controls and Indicators

control and Indicators	functions
Power Switch	<p>Controls monocular and IR source, ON or OFF.</p> <p>RESET/OFF Same as system OFF.</p> <p>OFF also resets monocular after high light cut-off.</p> <p>ON activates the monocular.</p> <p>IR/PULL momentarily activates the IR source when the knob is turned clockwise. Pull and turn the knob clockwise from the ON position to continuously activate the IR source.</p> <p style="text-align: center;"><u>CAUTION</u></p> <p style="text-align: center;">DO NOT USE EXCESSIVE FORCE TO PLACE THE POWERSWITCH INTO THE MOMENTARY IR</p>
Low Battery Indicator	A blinking yellow light indicates a low battery with less than 30 minutes of battery life remaining. It is visible through the eyepiece just outside the intensified field-of-view.
IR Source On Indicator	A steady red light indicates that the IR source is ON. It is visible through the eyepiece just outside the intensified field-of-view.
Gain Control	Adjusts the system gain from a minimum value of approximately 25 to a maximum value greater than 3,000.

Table 3-1 Controls and Indicators

Objective Focus	Focuses objective lens. Adjusts for sharpest image of viewed object.
Diopter Adjustment	Focuses eyepiece lens to user's eye. Adjust for sharpest image of intensifier screen.
Eye Relief Adjustment	Adjusts the distance between your eye and the monocular.
Latch	Latch used for separation of monocular from headmount/helmet mount adapter.
Battery Polarity Indicator	This feature, molded into the battery cartridge, shows the proper orientation of the batteries.
High Light Cut-off	The monocular will automatically cut off after 70+30 seconds of operation in daylight or bright room light. Individual bright lights (headlights, flashlights, or other concentrated light sources) will not actuate the high light detector located on the front of the monocular. To turn the monocular back ON, turn the power switch to RESET/OFF position and then to ON again.

Table 3-1 Controls and Indicators, (cont.)

3.3 Hand-held Operation:

CAUTION

**OPERATE THE MONOCULAR ONLY
UNDER DARKENED CONDITIONS OR USE
THE OBJECTIVE LENS CAP TO COVER
THE OBJECTIVE LENS FOR DAYLIGHT
CONDITIONS.**

NOTE

WHEN USING THE MONOCULAR WITHOUT A MOUNTING DEVICE, MAKE SURE TO PLACE THE NECK CORD AROUND YOUR NECK.

1. Ensure that the battery is installed correctly.
2. Turn the power switch to ON.

NOTE

THE SHARPEST IMAGE WILL BE OBSERVED ONLY WHEN THE OBJECTIVE LENS AND EYEPIECE LENS ARE PROPERLY FOCUSED.

3. Rotate the diopter adjustment for the clearest view of the image intensifier screen.
4. Focus the objective lens while observing an object until the sharpest image is obtained.

3.4 Head Mounted Operation:

CAUTION

OPERATE THE MONOCULAR ONLY UNDER DARKENED CONDITIONS OR USE THE LENS CAP TO COVER THE OBJECTIVE LENS FOR DAYLIGHT CONDITIONS.

1. Ensure that battery is installed correctly.
2. Put on the headmount following the instructions found in paragraph 2.7.

NOTE

TO MAKE IT EASIER TO ALIGN THE MONOCULAR, EYECUP, AND EYEPiece LENS TO THE EYE, DEPRESS THE EYE RELIEF ADJUSTMENT AND SLIDE THE HEADMOUNT SOCKET ALL THE WAY FORWARD BEFORE ATTACHING THE MONOCULAR.

3. Align the headmount/helmet mount adapter's latch to the headmount socket. Press and hold down the latch lever while installing the monocular into the headmount socket. Release the latch when the monocular fully engages the socket.
4. Set your eye relief by depressing the eye relief adjustment and move the monocular back toward your non-dominant eye until the eyecup comfortably seals around the eye.
5. Turn the monocular ON.
6. Loosen the clamp knob and adjust monocular until it is properly aligned with your eye. Tighten the clamp knob to secure the monocular.

NOTE

THE SHARPEST IMAGE WILL BE OBSERVED ONLY WHEN THE OBJECTIVE LENS AND EYEPiece LENS ARE PROPERLY FOCUSED.

7. Rotate the diopter adjustment for the clearest view of the image intensifier screen.

NOTE

ANY READJUSTMENT OF EYE RELIEF REQUIRES READJUSTMENT OF THE DIOPTER.

8. Adjust the eye relief distance by pressing the eye relief adjustment and sliding the monocular fore or aft to obtain a full field-of-view of the image. Reset the diopter adjustment for best image.
9. Adjust the objective lens focus (Figure 3-1) while observing an object until the sharpest image is obtained.
10. If the monocular is removed from the headmount while operating, the monocular will be powered OFF. To return to normal operation, cycle the power switch knob from ON to OFF/RESET and back to ON.

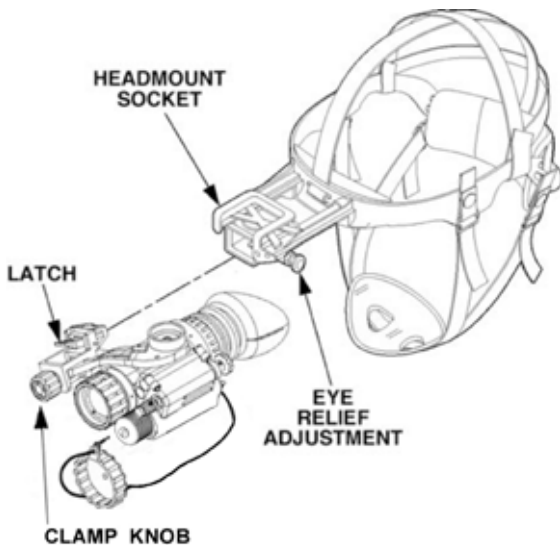

Figure 3-2 Head Mounted Operation

3.5 Operations with IR Source:

WARNING

THE IR SOURCE IS A LIGHT THAT IS INVISIBLE TO THE UNAIDED EYE FOR USE DURING CONDITIONS OF EXTREME DARKNESS. HOWEVER, THE LIGHT FROM THE IR SOURCE CAN BE DETECTED BY THE ENEMY USING NIGHT VISION DEVICES.

NOTE

THE PURPOSE OF THE IR SOURCE IS FOR VIEWING AT CLOSE DISTANCES UP TO 3 METERS WHEN ADDITIONAL ILLUMINATION IS NEEDED.

1. Pull the power switch knob out and rotate clockwise to the IR position. With the monocular held to the eye, observe that a red light appears in the eyepiece. This indicates that the IR source is operating.
2. For momentary IR use, turn the power switch knob clockwise (without pulling) past the ON position. Observe that a red light appears in the eyepiece. When the switch knob is released, the knob will return to the ON position and the IR source will be powered OFF.

3.6 Using the Gain control:

Turn the gain control to provide the optimum illumination input to the eye.

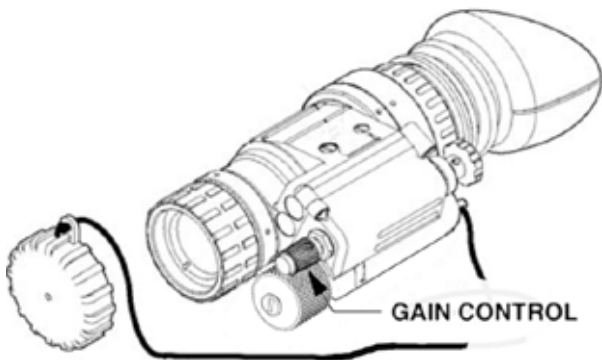

Figure 3-3 Gain Control

3.7 Operation in conditions of blowing Dust or Sand:

CAUTION

OPERATION IN CONDITIONS OF BLOWING DUST OR SAND CAN PIT AND SCRATCH THE OPTICAL ELEMENTS AND DAMAGE THE MECHANICAL COMPONENTS UNLESS THE PRECAUTIONS GIVEN BELOW ARE OBSERVED.

1. Ensure that the sacrificial window is in place.
2. Avoid pointing the monocular into the wind unless necessary for operation.
3. Keep the carrying case closed unless removing or replacing items.

4. Ensure that all dust and sand is removed from the PVS-14A and carrying case after operation.

3.8 Operation in Rainy or Humid conditions:

CAUTION

OPERATION IN RAINY OR HUMID CONDITIONS CAN CAUSE CORROSION AND DETERIORATION OF THE PVS-14A UNLESS THE PRECAUTIONS GIVEN BELOW ARE OBSERVED

1. Install the demist shield as instructed in this manual.
2. Keep the carrying case closed unless removing or replacing items.
3. Dry the monocular, mounts, and accessories after exposure to rain or high humidity and before storage.
4. Do not store monocular in a wet carrying case.

3.9 Operation in Salt Water Areas:

After exposure to salt water, clean the unit as instructed in this manual, after rinsing with fresh water.

3.10 Shutting Down the Unit:

Perform the following procedures to shut down the monocular.

1. Turn the monocular power switch to the OFF position.
2. Remove the monocular from the headmount, helmet mount or weapon and remove the weapon mount from the monocular.

3.11 Preparation for Storage:

1. Remove battery from the monocular.
2. Inspect the battery housing for corrosion or moisture. Clean

- and dry if necessary.
3. Replace the battery cap.
 4. Remove the demist shield or sacrificial window if installed.
Install objective lens cap.

NOTE

**PRIORTOPLACINGPVS-14AINTOCARRYING
CASE, ENSURE PVS-14AAND CASE ARE
FREE OF DIRT, DUST, AND MOISTURE.**

5. Place the monocular, accessories and cleaning supplies back into their storage/carrying case. It is best to place the items in their original locations to prevent any possible damage to the unit and/or accessories.
6. Return to storage area.

This page intentionally left blank.

CHAPTER 4:

MAINTENANCE INSTRUCTIONS

4.1 Introduction:

The PVS-14A is designed to be used in diverse environments and rugged conditions. It is recommended that regular and simple maintenance be performed for optimal system performance.

CAUTION

THE MONOCULAR IS A PRECISION ELECTRO-OPTICAL INSTRUMENT AND MUST BE HANDLED CAREFULLY.

DO NOT SCRATCH THE EXTERNAL LENS SURFACES OR TOUCH THEM WITH YOUR FINGERS.

WIPING DEMIST SHIELD WITH LENS TISSUE WHILE WET OR WITH WET LENS TISSUE CAN DAMAGE THE COATING.

4.2 Deactivation:

Power down the system by turning the power switch knob to OFF.

4.3 Battery Removal:

Open battery compartment, remove battery and store in carrying case. Close the battery compartment before cleaning.

4.4 Cleaning the PVS-14A:

When necessary, use a moistened clean cloth to wipe the outside of the unit, EXCEPT FOR THE OPTICAL SURFACES.

Be sure to wipe away excess dirt and dust that may restrict the performance of and damage moving and mating parts. If needed, the use of a very diluted detergent solution is permissible. Dry with a soft clean cloth, or allow unit to air-dry before storing it.

4.5 Cleaning the Optics:

When cleaning of the lens is required, first blow any loose dirt or grit away from the surface of the lens. EXCEPT FOR THE DEMIST SHIELD, use the supplied lens tissue lightly moistened with water or lens cleaning fluid to lightly wipe the optical surfaces, using a circular motion. Discard each lens tissue after one use to avoid transferring grit or foreign matter onto the lens surfaces. If the lens remains dirty use a cotton swab lightly moistened with lens cleaning fluid to remove the foreign matter from the lens. Dry with a clean unused lens tissue.

4.6 Checking for Damage and corrosion:

As a general guideline, conduct an inspection of the PVS-14A, accessories, and the case after every use. Look for heavy wear and cracks in rubber or plastic. Inspect for moisture or corrosion in electronic housings and in the battery compartment. Check for scratches, condensation and foreign matter on optical surfaces. Report missing or damaged items, for replacement.

CHAPTER 5: TROUBLESHOOTING

5.1 Troubleshooting Procedures:

Table 5-1 lists common malfunctions that may occur with the equipment. Perform the tests, inspections and corrective actions in the order they appear in the table.

This table cannot list all the malfunctions that may occur, all the tests and inspections needed to find the fault, or all the corrective actions needed to correct the fault. If the equipment malfunction is not listed or actions listed do not correct the fault, notify your maintainer.

Malfunction	Test for Inspection	corrective Action
Monocular fails to activate.	Visual. Check for defective, missing or improperly installed battery.	Turn switch to RESET/OFF position and then ON. Replace battery or install correctly. If PVS-14A still fails to activate, refer to higher level of maintenance.

Table 5-1 Troubleshooting

IR source fails to activate.	In a dark location with system turned on, activate IR source. Visually check IR source operation; scene should brighten.	If IR source still fails to activate, refer to higher level of maintenance.
IR source indicator fails to activate.	Visual.	Refer to higher level of maintenance.
Poor image quality.	Check objective lens or eyepiece. Check for fogging or dirt on objective lens or eyepiece lens. Check eye relief distance.	Refocus. Clean lens surface per paragraph 4.5. Readjust for proper eye relief distance.
Light visible around eyecup.	Check eyecup for resiliency.	If eyecup is defective, refer to higher level of maintenance.
Diopter adjustment cannot be made.	Check to see if the diopter adjustment is bent or broken.	If damaged, refer to higher level of maintenance.
Head straps cannot be tightened.	Check for defective buckles, fasteners or straps.	If damaged, refer to higher level of maintenance.

Table 5-1 Troubleshooting, (cont.)

<p>Headmount socket and headmount adapter latch do not catch.</p>	<p>Check socket or latch for dirt.</p> <p>Check socket or latch for damage.</p>	<p>Clean socket and latch.</p> <p>If damaged, return either headmount to higher level of maintenance.</p>
<p>Monocular does not cut off when exposed to high light.</p>	<p>Visual.</p> <p>Perform the following test under daylight or bright room light (not fluorescent light).</p> <p>Place the objective lens cap on the objective lens. Turn monocular ON and observe that it cuts off within 70 ± 30 seconds after energized.</p> <p>Turn monocular OFF and then ON to reenergize monocular.</p>	<p>If damaged, return to higher level of maintenance.</p>

Table 5-1 Troubleshooting, (cont.)

This page intentionally left blank.

APPENDIX A: REPAIR & SPARES

A.1 Introduction:

This section provides information needed to identify, contact and order spare and/or repair parts for the DTNVG.

A.2 Contact Information:

To order spare or repair parts for the DTNVG or any of your night vision products contact:

**ACTinBlack Europe S.à r.l.
12 Rue de l'Industrie,
L-3895 Foetz,
Grand Duchy of Luxembourg
info@actinblack.com**

This page intentionally left blank.

APPENDIX B: WARRANTY INFORMATION

Defects after Delivery and Warranty

Subject to the following provisions, ACTinBlack Europe S.à.r.l. warrants to Purchaser that the goods manufactured by ACTinBlack Europe S.à.r.l. shall be free from defects in material and workmanship. ACTinBlack Europe S.à.r.l. obligations, set forth below, shall apply only to failures to meet the foregoing warranties for parts only occurring within Twelve (12) months from the date of shipment.

The warranty terms may be modified on the basis of the ruling Warranty Policy of ACTinBlack Europe S.à.r.l. only with written agreement.

The Purchaser shall grant ACTinBlack Europe S.à.r.l. such adequate time and opportunity as deemed reasonable to remedy failures to meet the foregoing warranties. To remedy such failures, ACTinBlack Europe S.à.r.l. shall repair or, at its option, replace the defective product.

ACTinBlack Europe S.à.r.l. obligation to repair or replace as aforesaid shall not apply to any goods which are normally consumed in operation, or have a normal life inherently shorter than the warranty period specified above, or are not properly stored, installed, used, maintained or repaired or are modified other than pursuant to ACTinBlack Europe S.à.r.l. instructions or approval, or have been subjected to any other kind of misuse or detrimental exposure, or have been involved in an accident.

ACTinBlack Europe S.à.r.l. shall have no warranty obligations with respect to defects resulting from inexpert alterations or repairs carried out by the Purchaser or his agent.

Return Material Authorization Number (RMA#):

Warranty and non-warranty items returned to ACTinBlack Europe S.à.r.l. for repair or replacement require a RMA#.

Email info@actinblack.com, with a serial number and detailed information to obtain a RMA#.

THIS WARRANTY IS EXCLUSIVE AND IN LIEU OF ANY OTHER WARRANTY, EITHER EXPRESSED OR IMPLIED, INCLUDING WARRANTIES OF MERCHANTABILITY OR FITNESS FOR PURPOSE.



ACTinBlack Europe S.à r.l.
12 Rue de l'Industrie,
L-3895 Foetz,
Grand Duchy of Luxembourg
www.actinblack.com