

Sagaon

CNC 5040/100100



Manual de ensemble

Paso 1: Marco

1.-

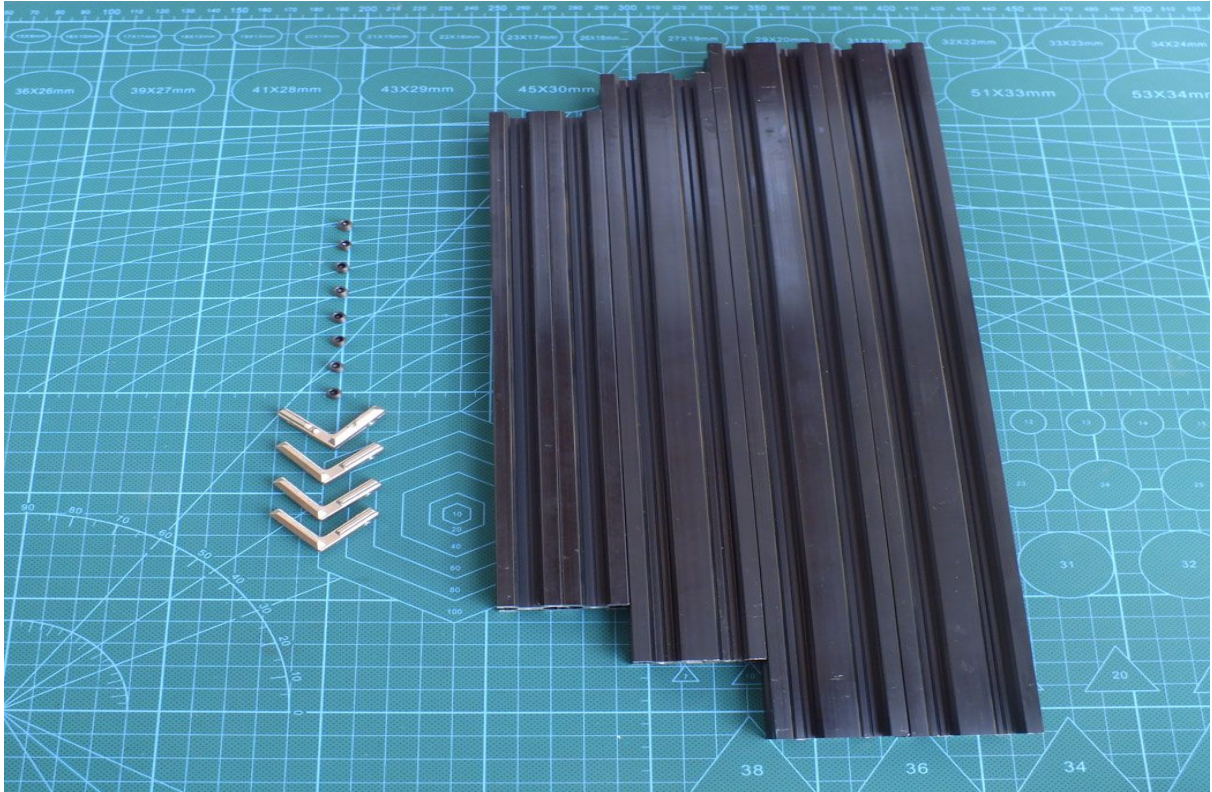

2.-

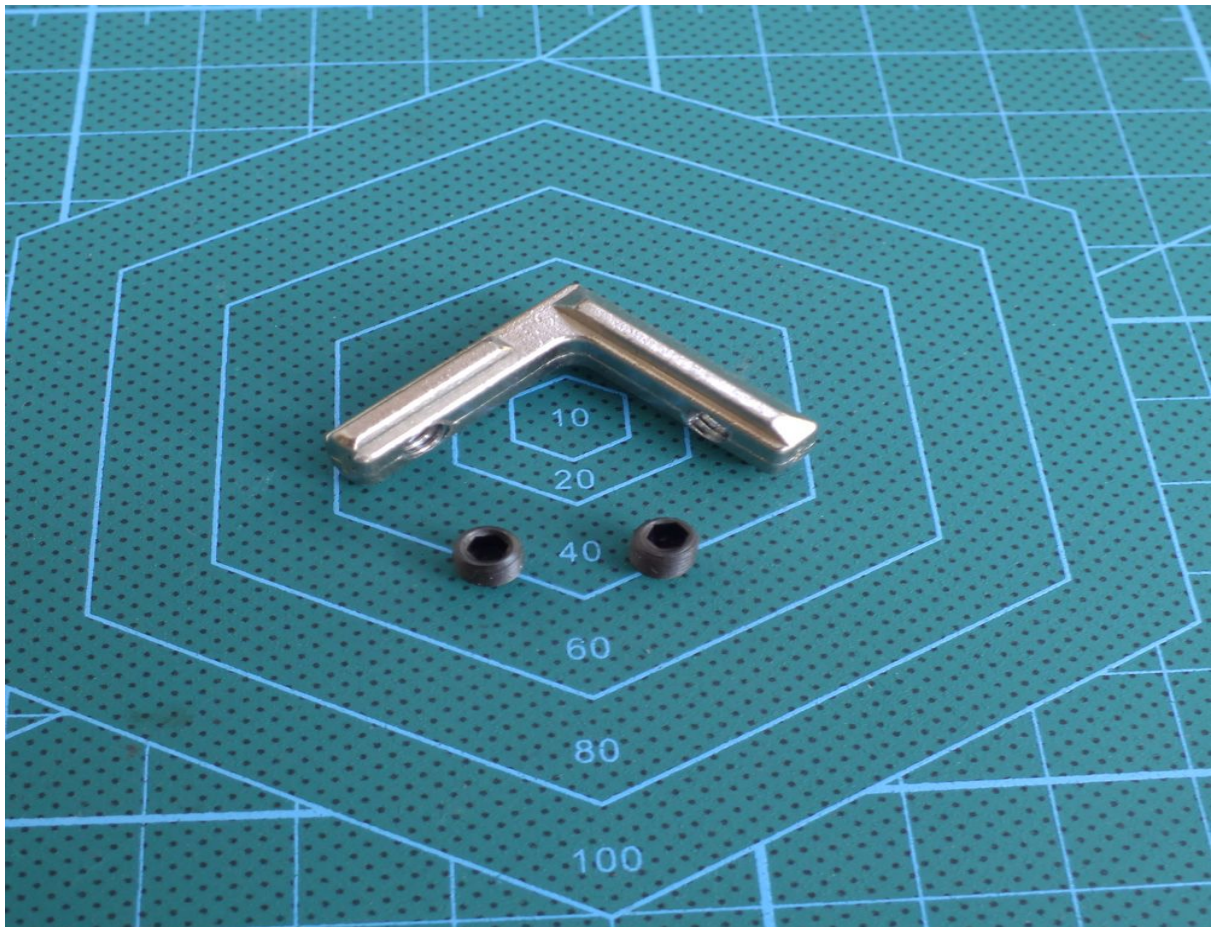

Sagaon

3.-

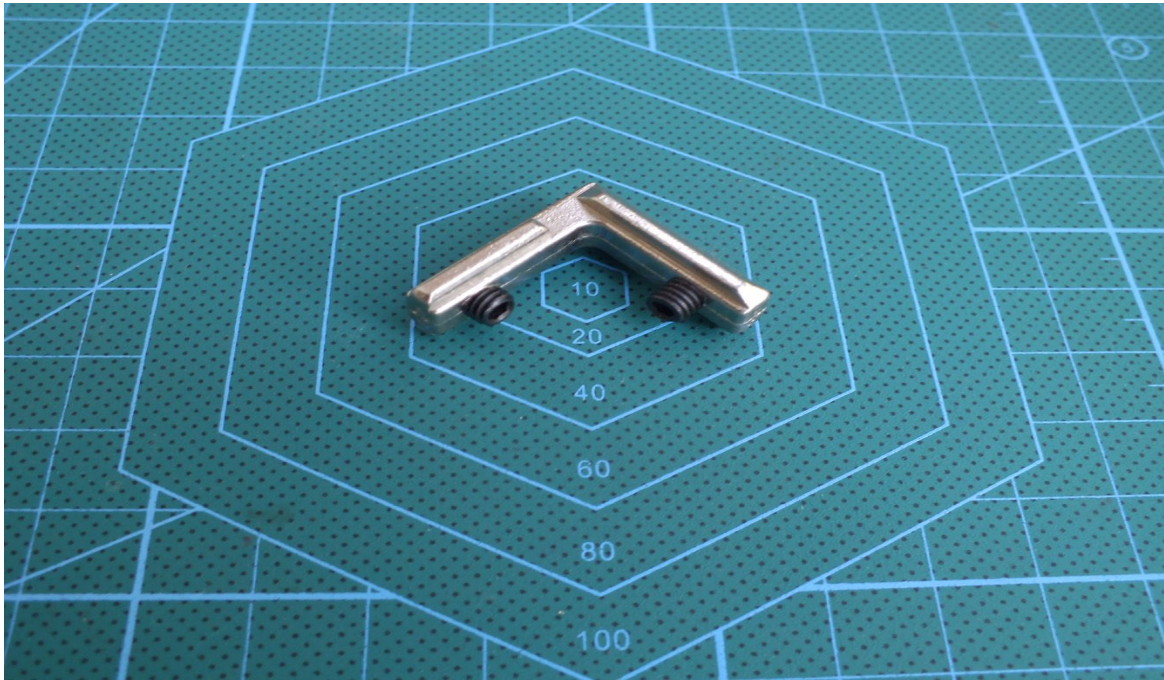

4.-

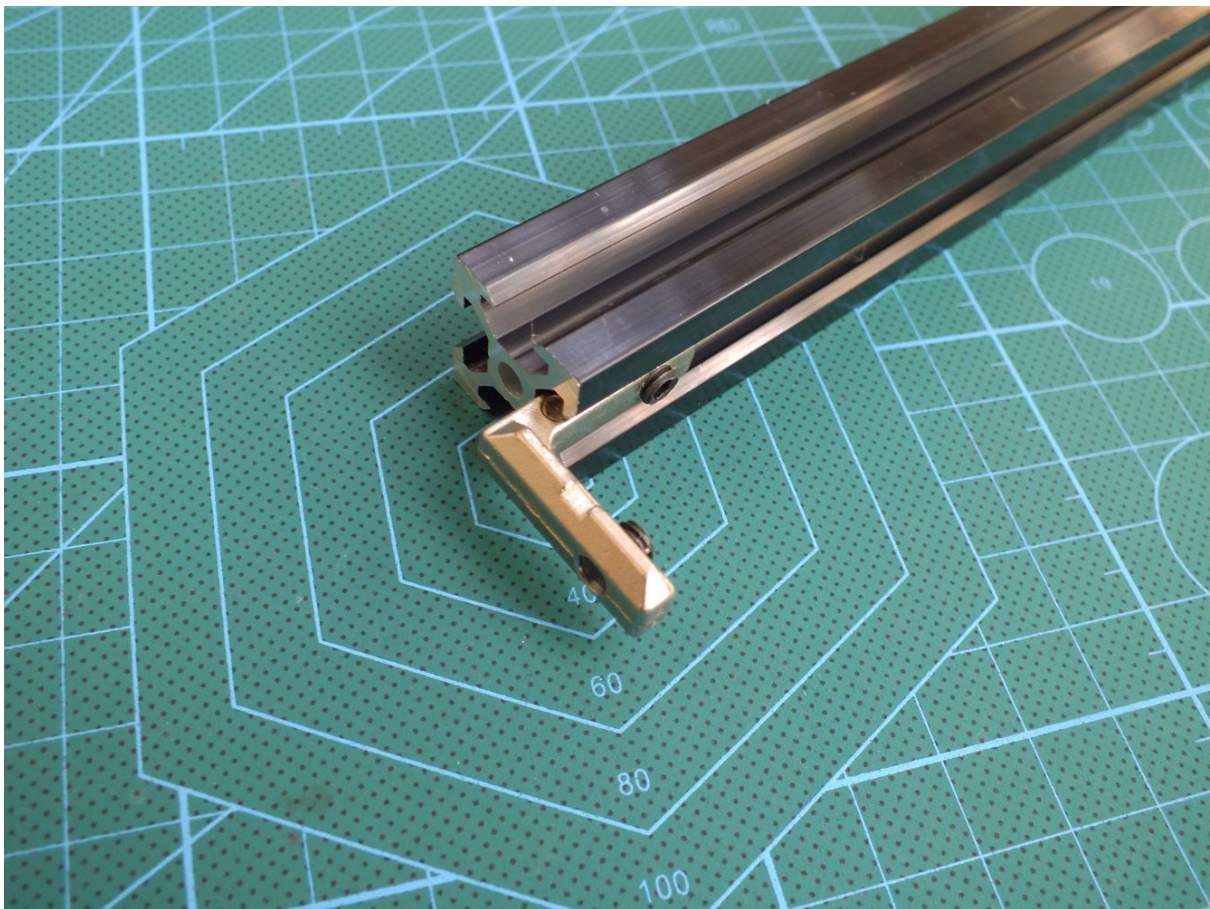

Sagaon

5.-

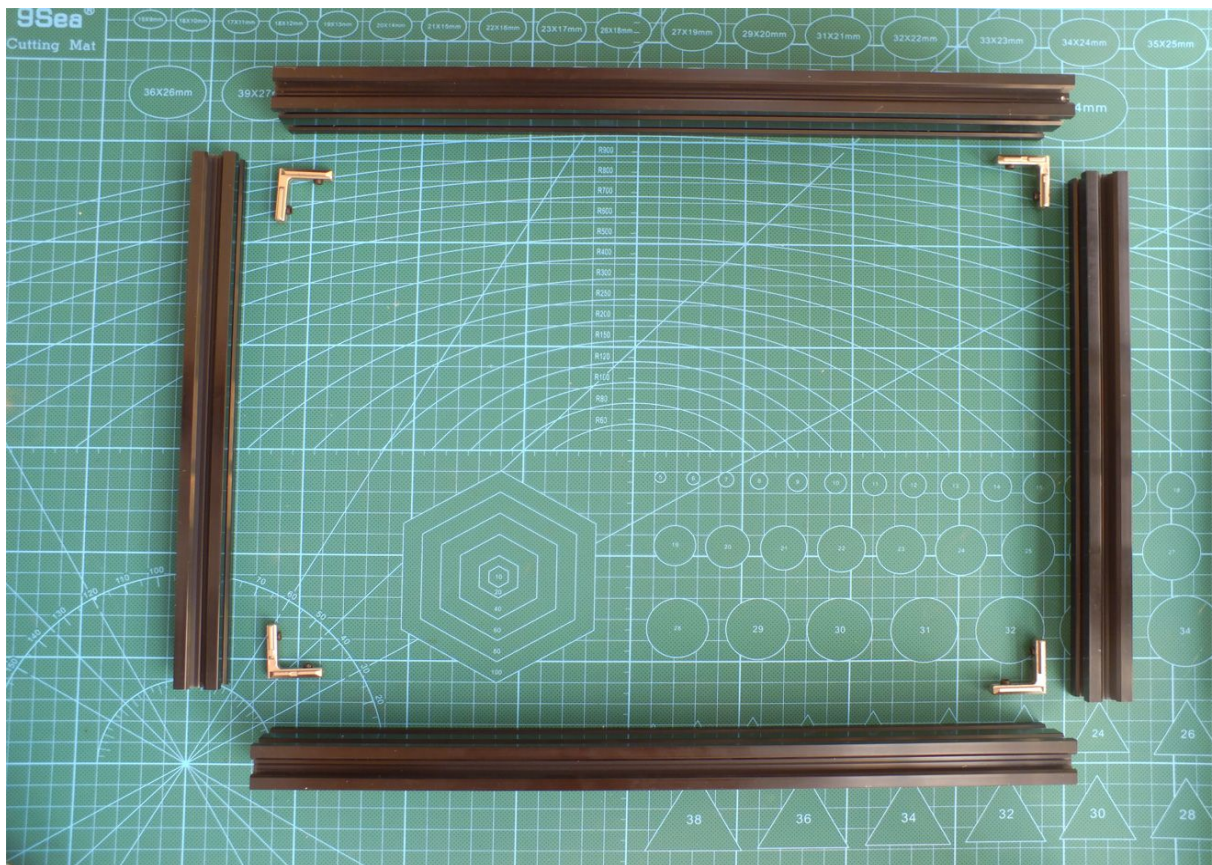

6.-

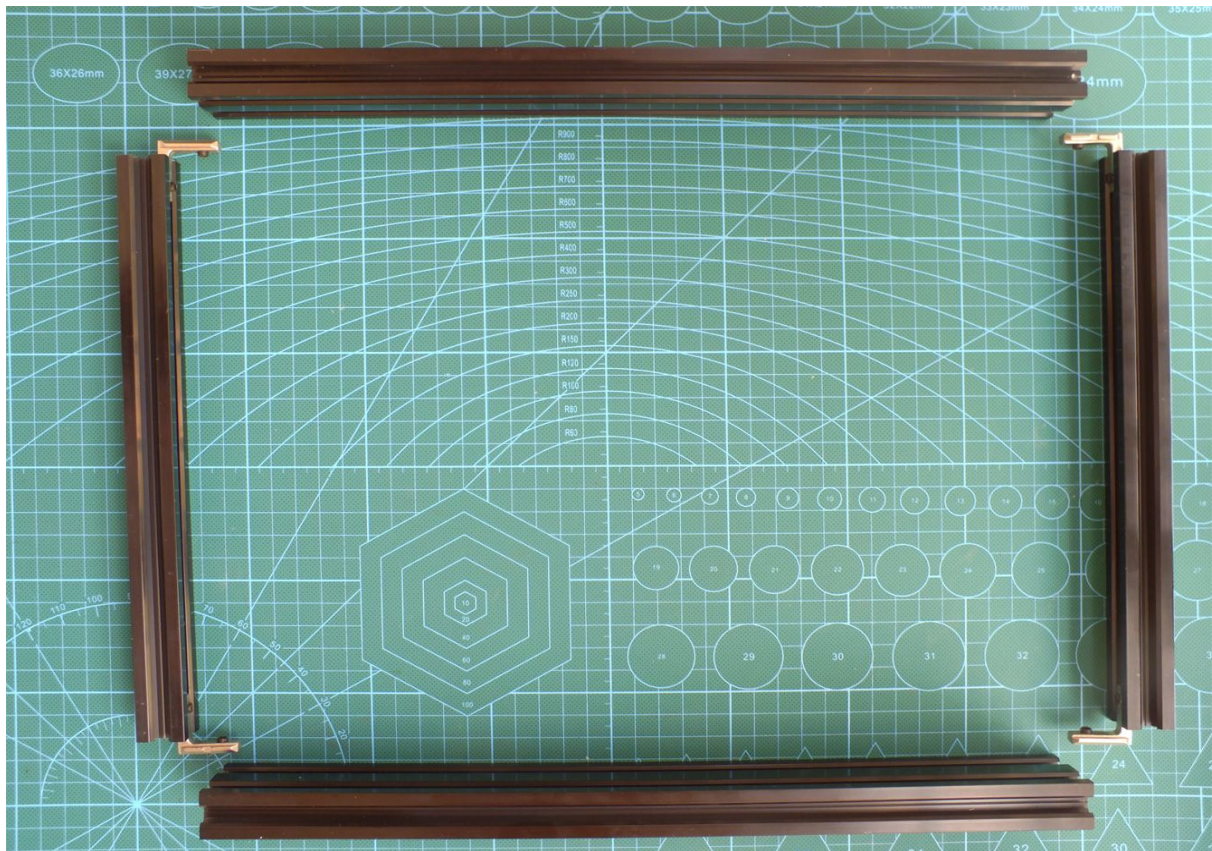

Sagaon

7.-



8.-

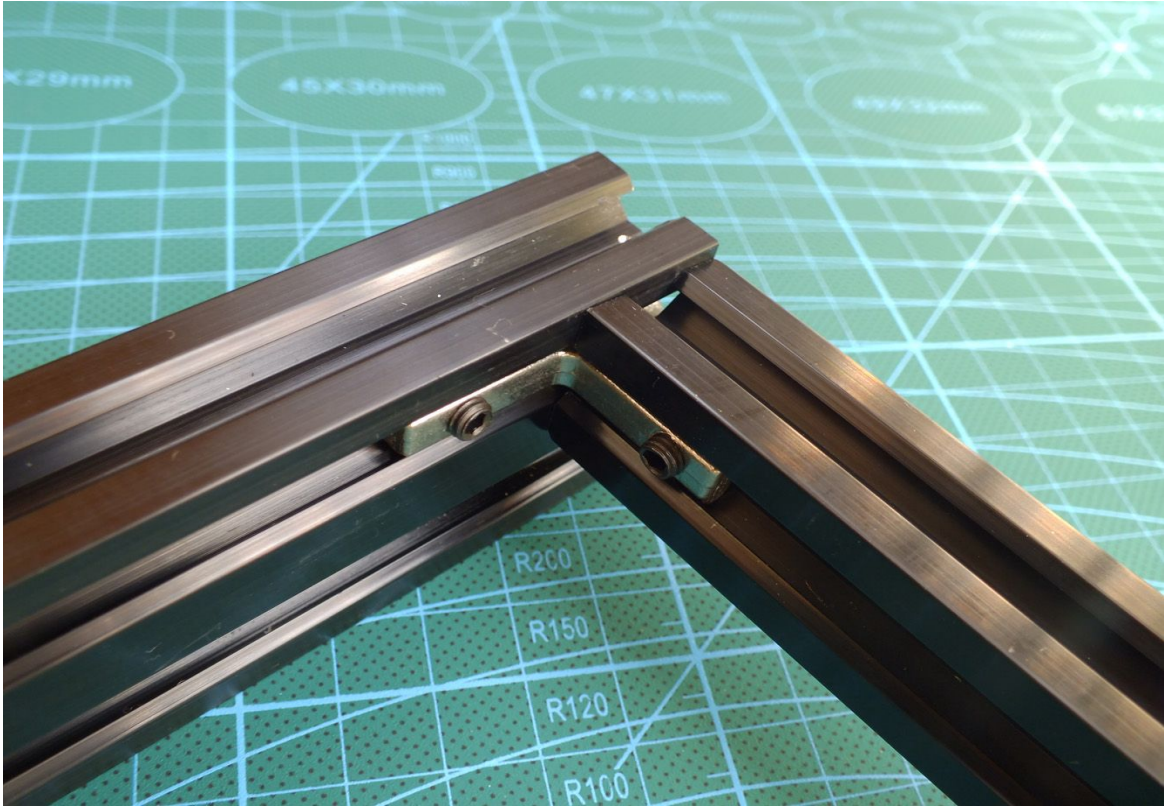

Paso 2: Motores ejes Y

1.-

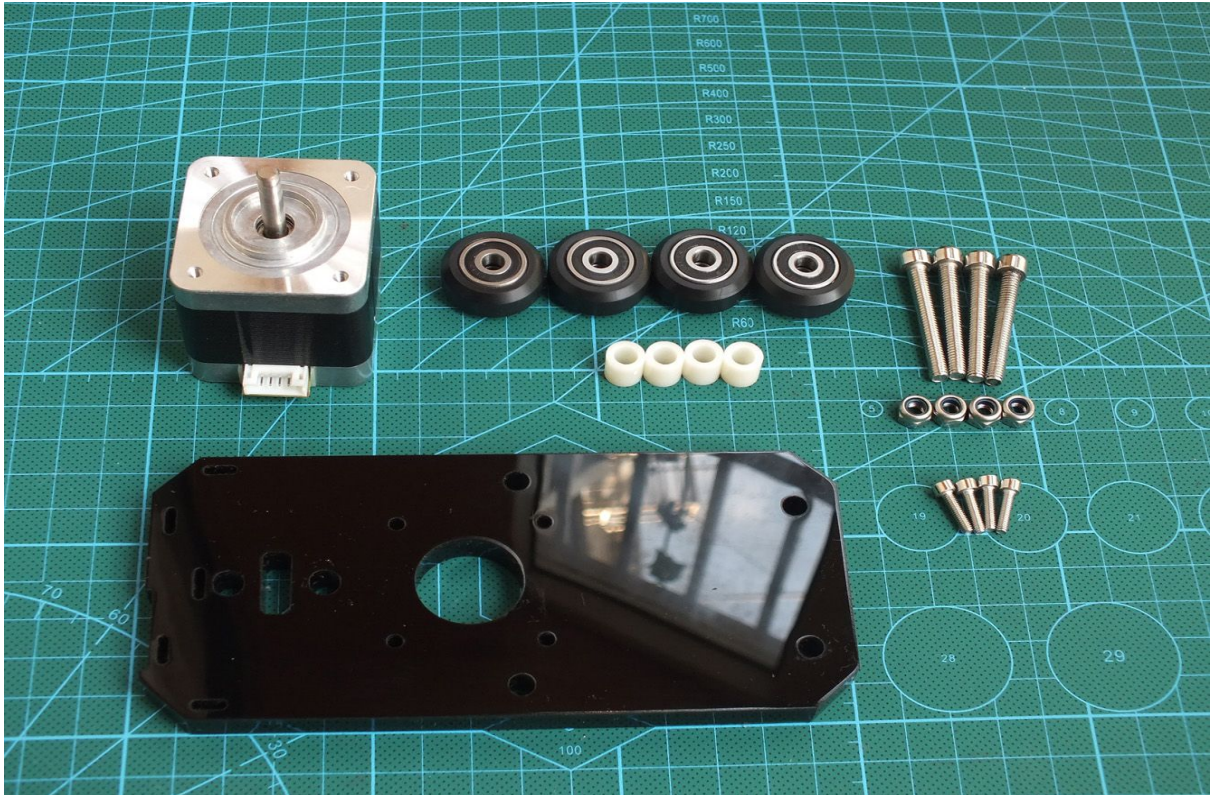

2.-

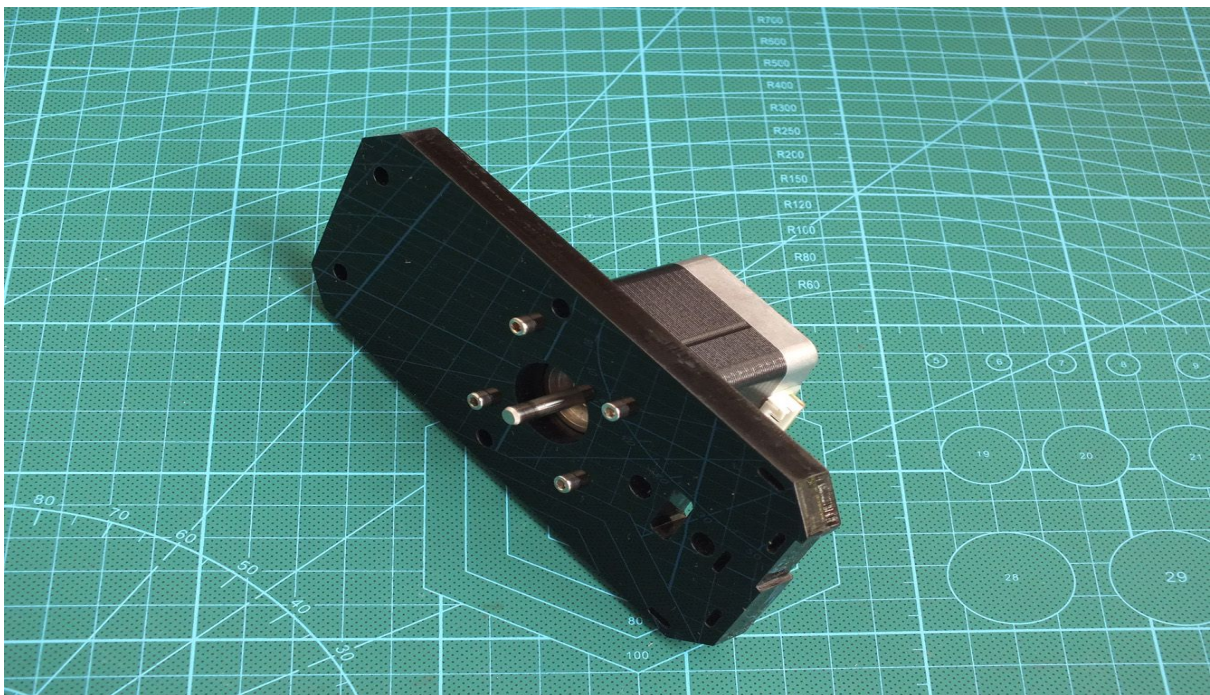

3.-

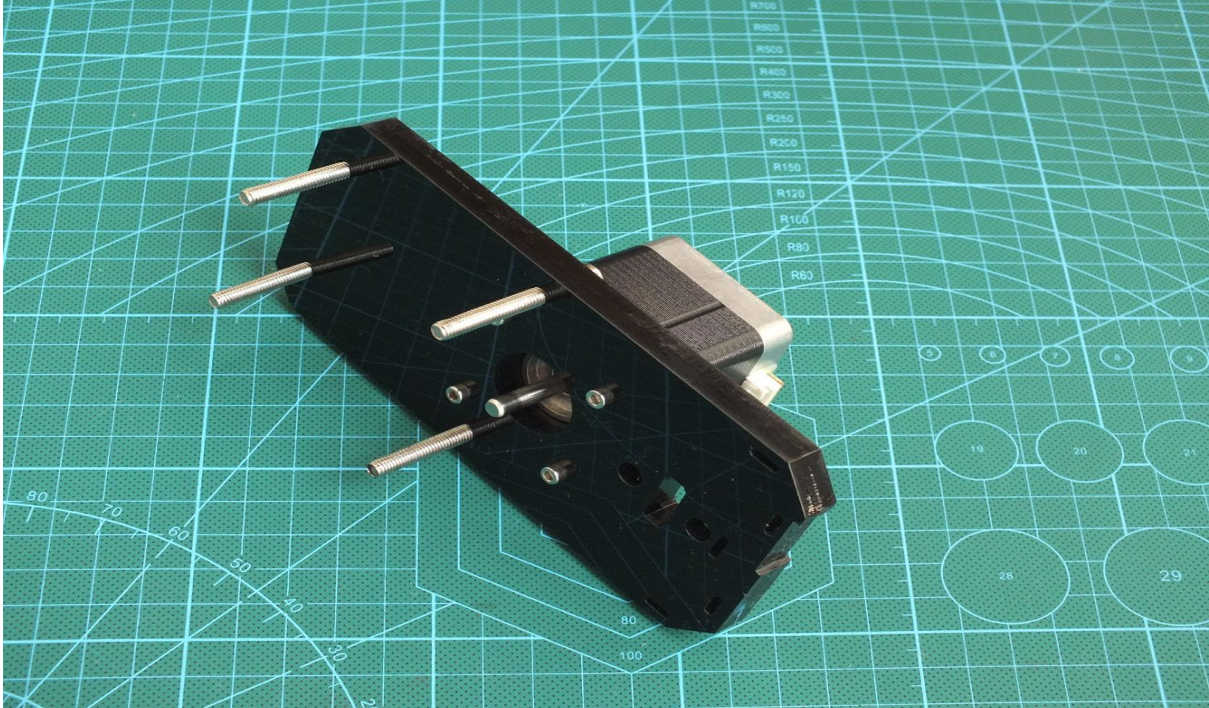

4.-

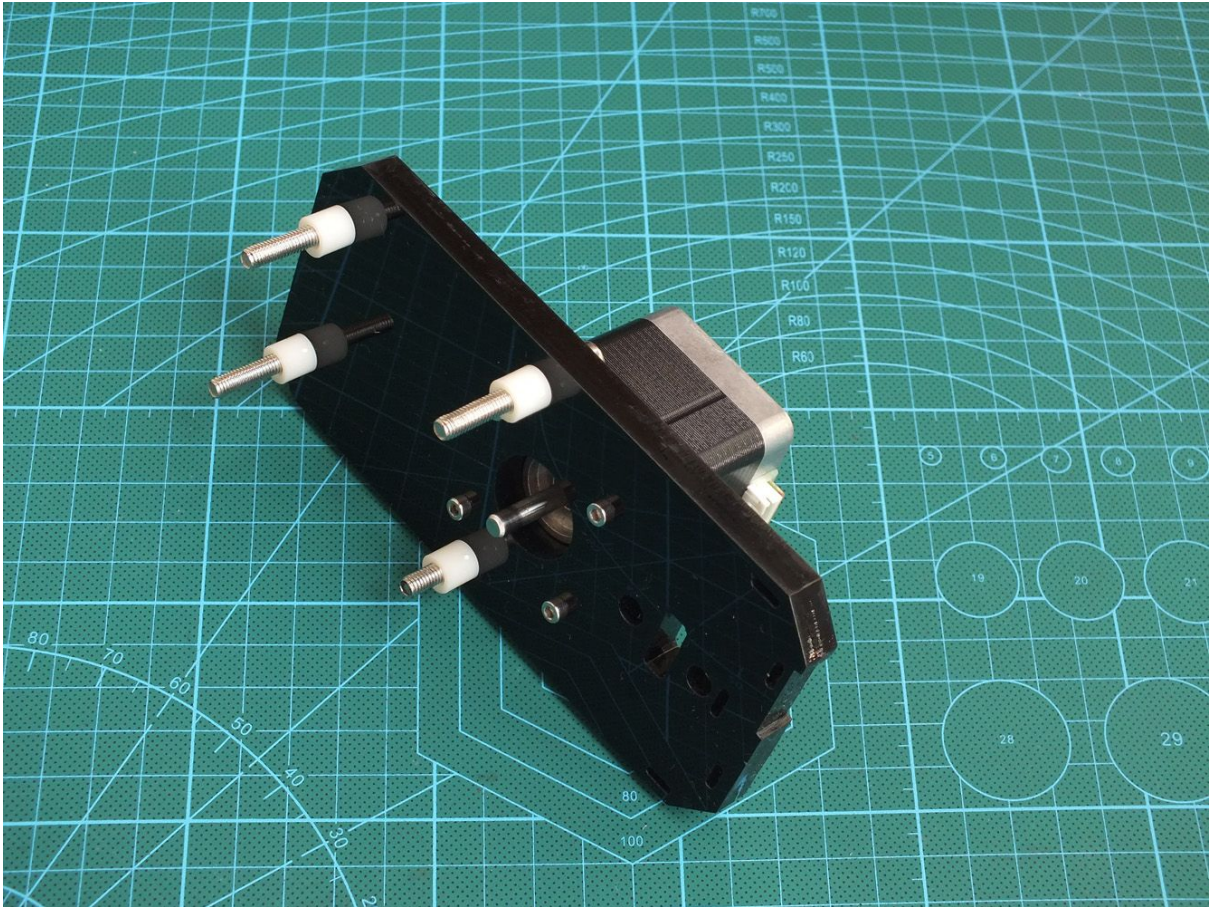

Sagaon

5.-

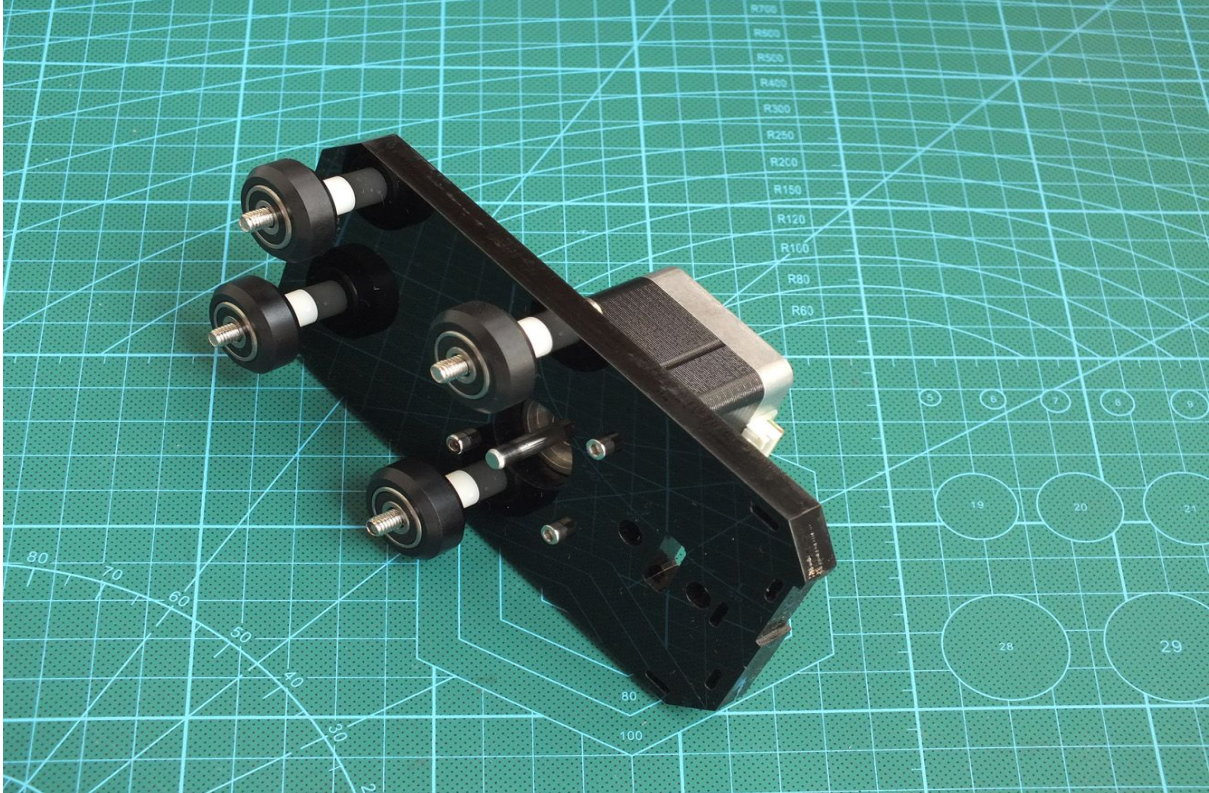

6.-

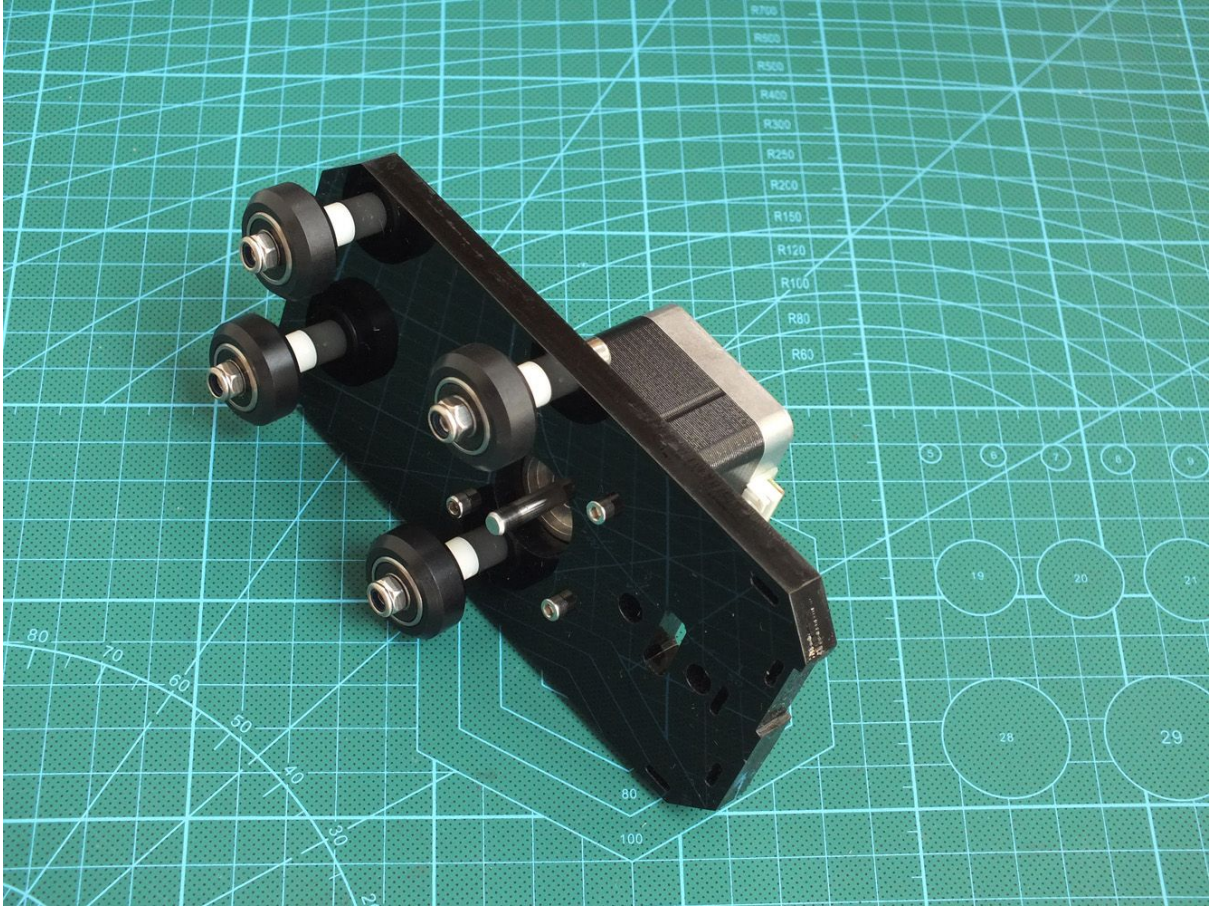

Sagaon

7.-

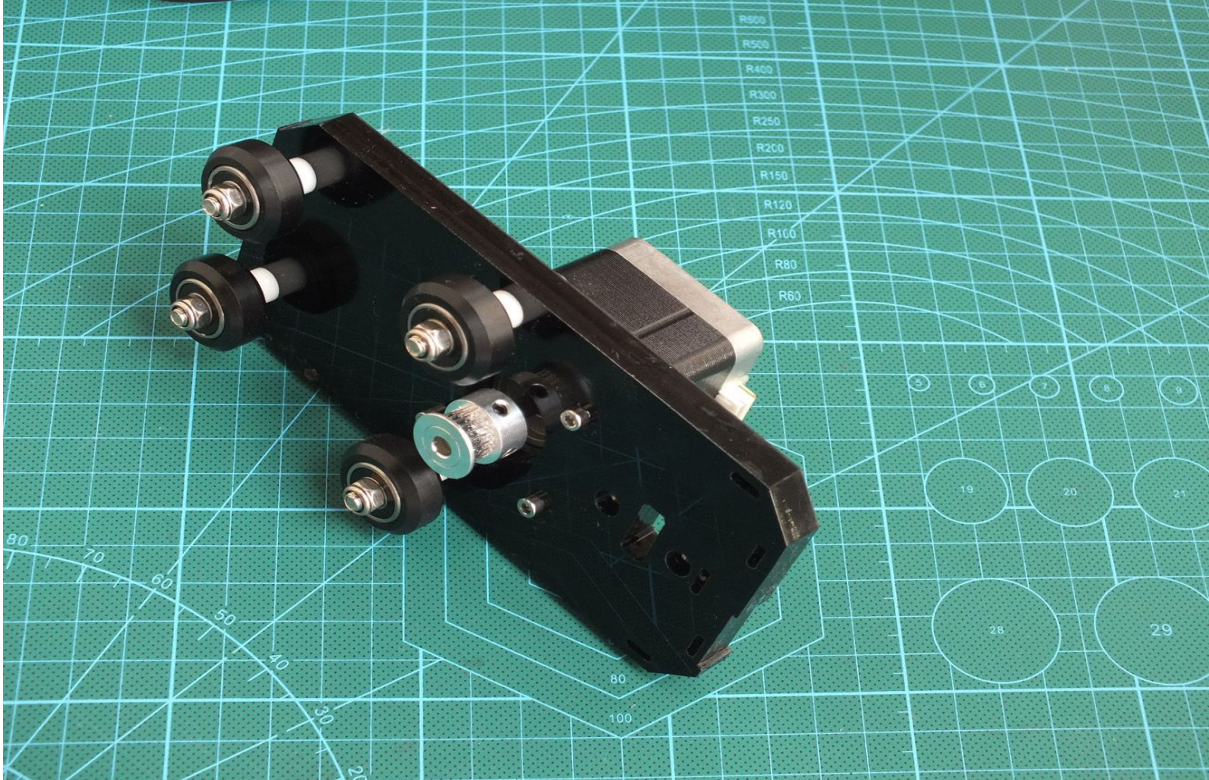

8.-



Paso 3: Ensamble de motor y laser en placa de eje X

1.-

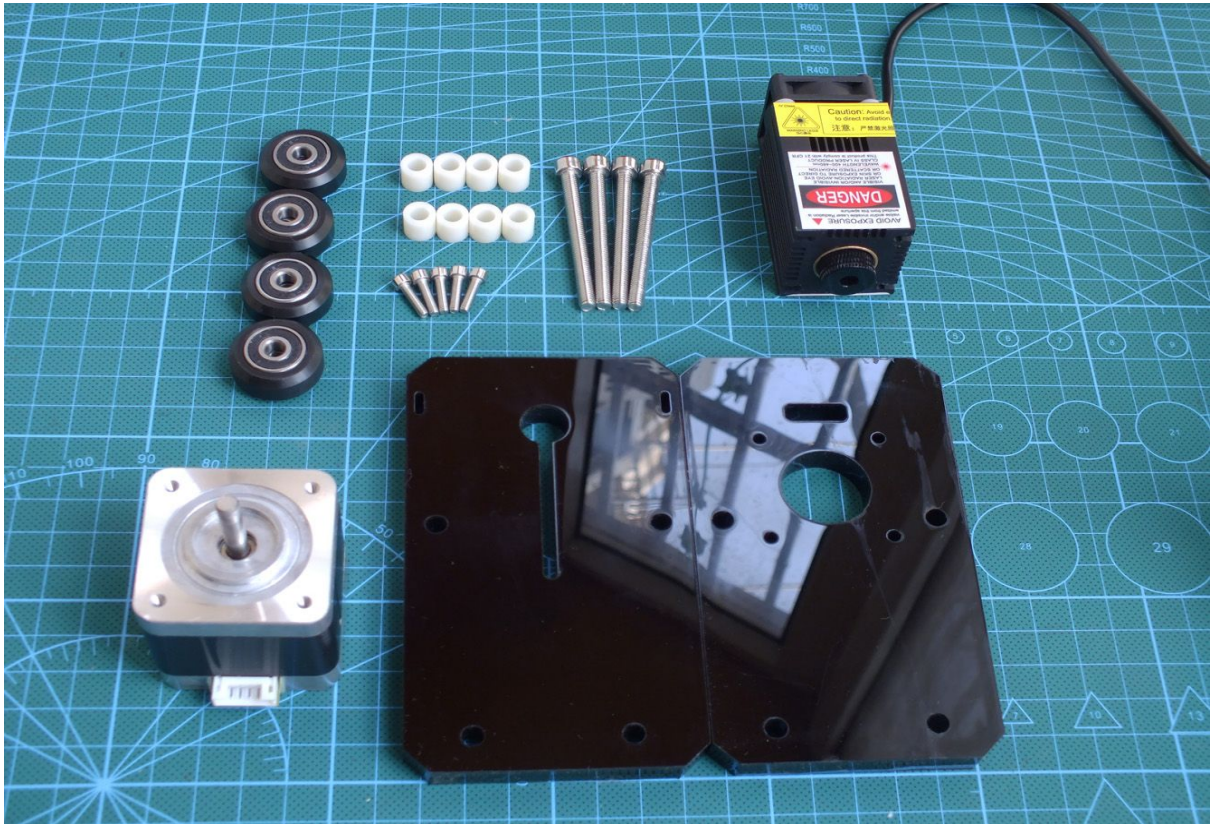

2.-

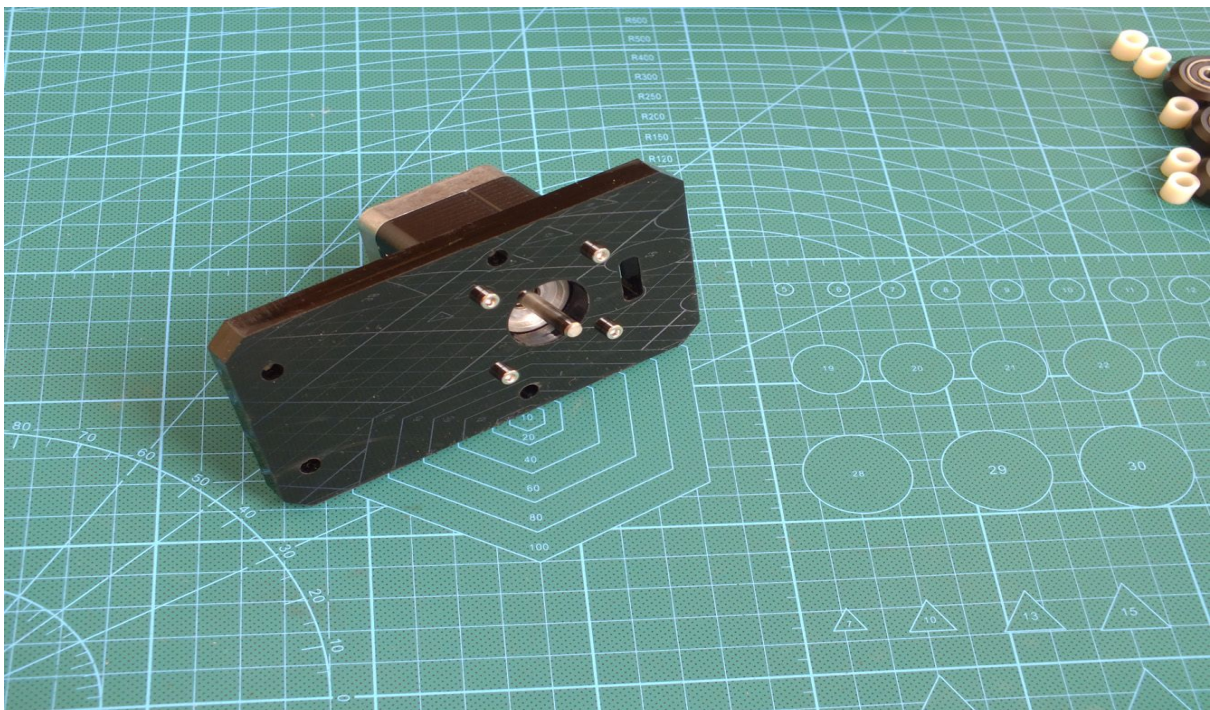

Sagaon

3.-

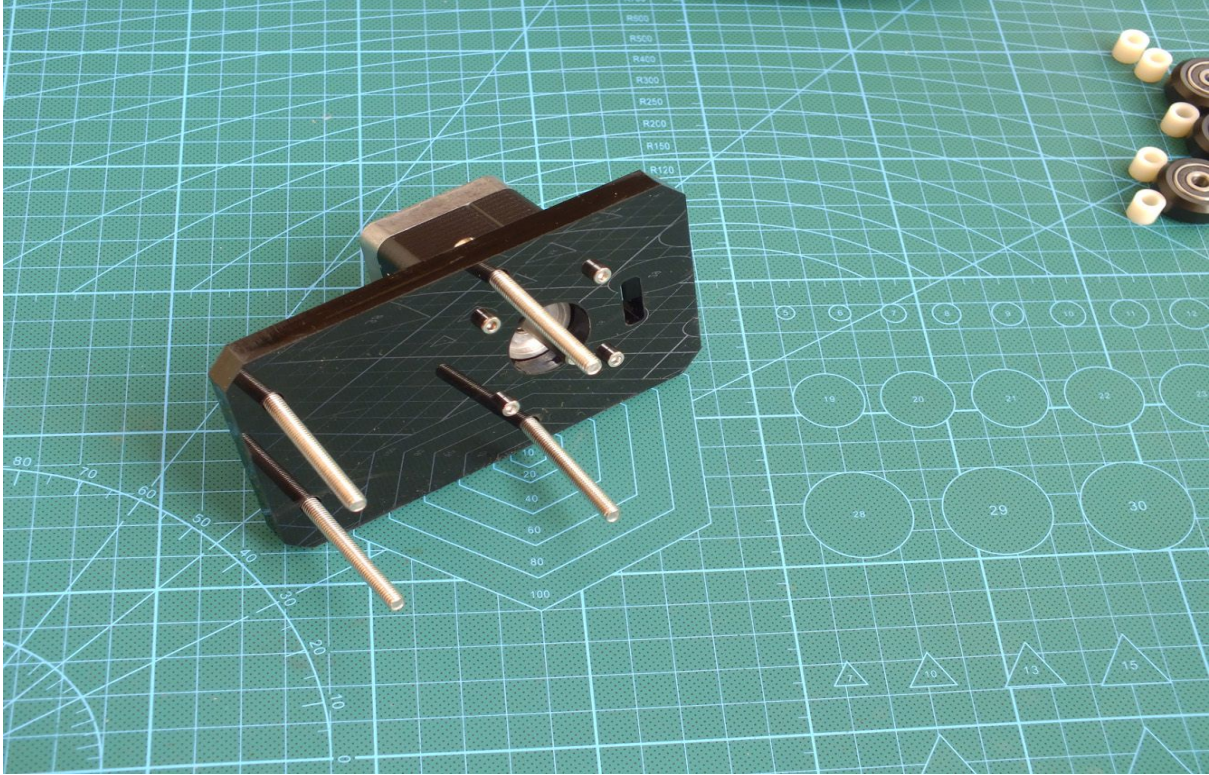

4.-

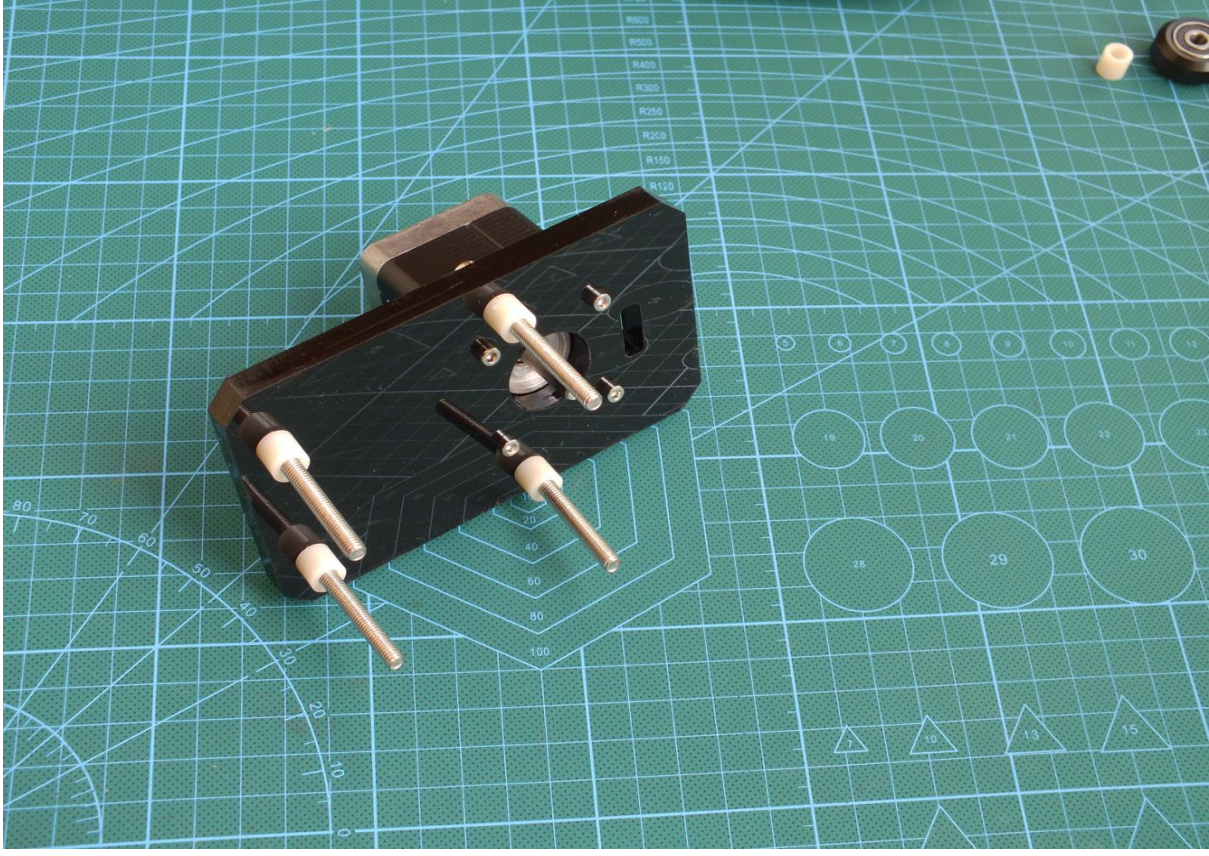

Sagaon

5.-

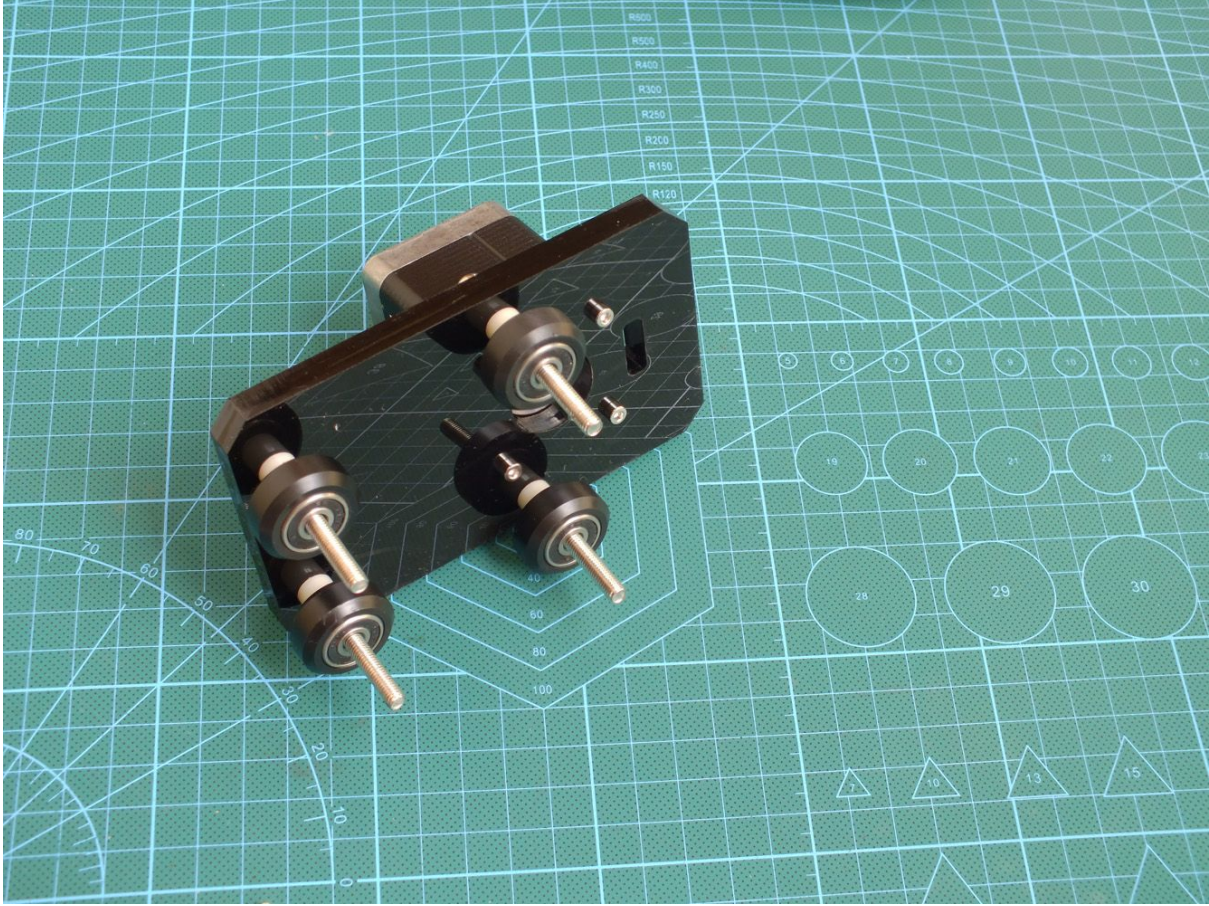

6.-

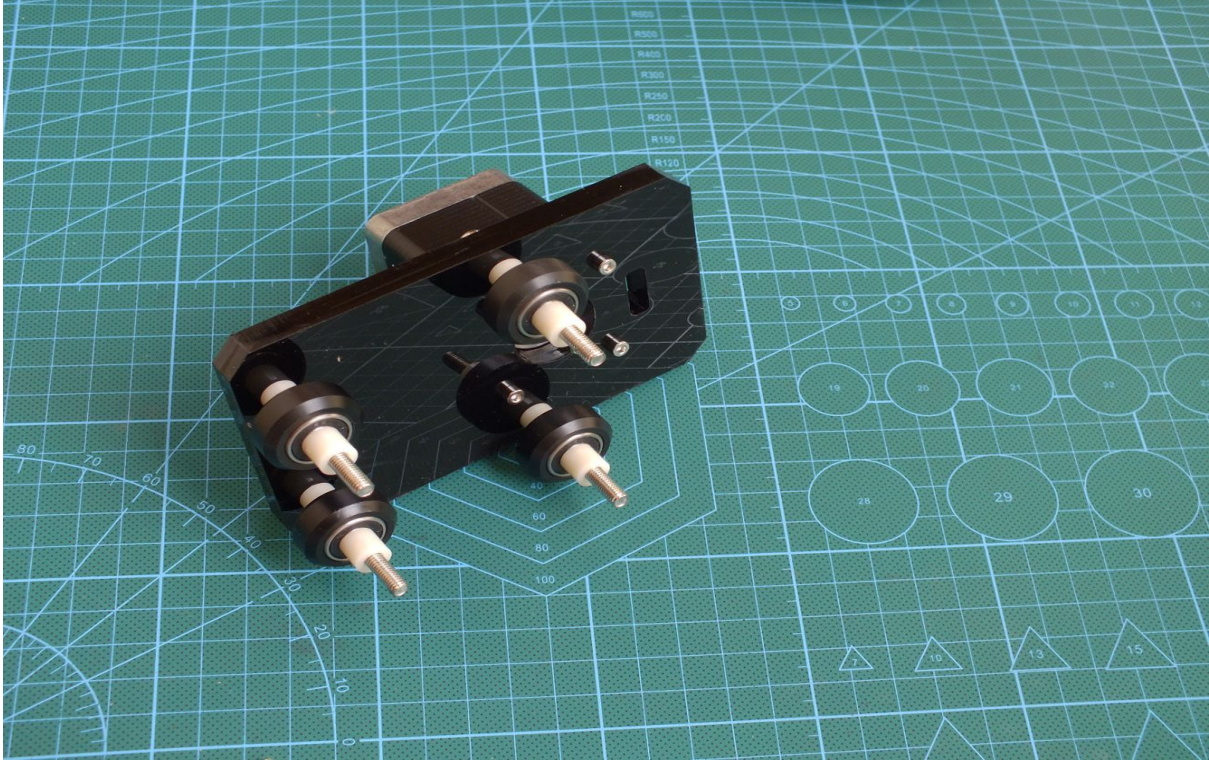

Sagaon

7.-

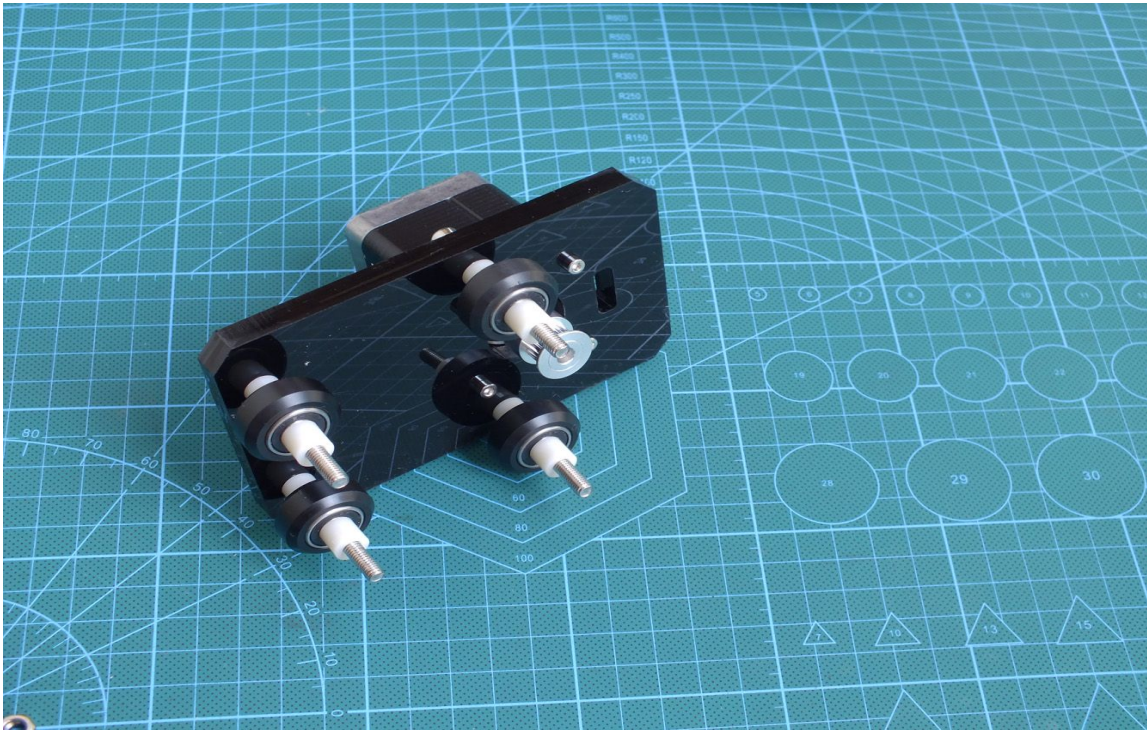

8.-

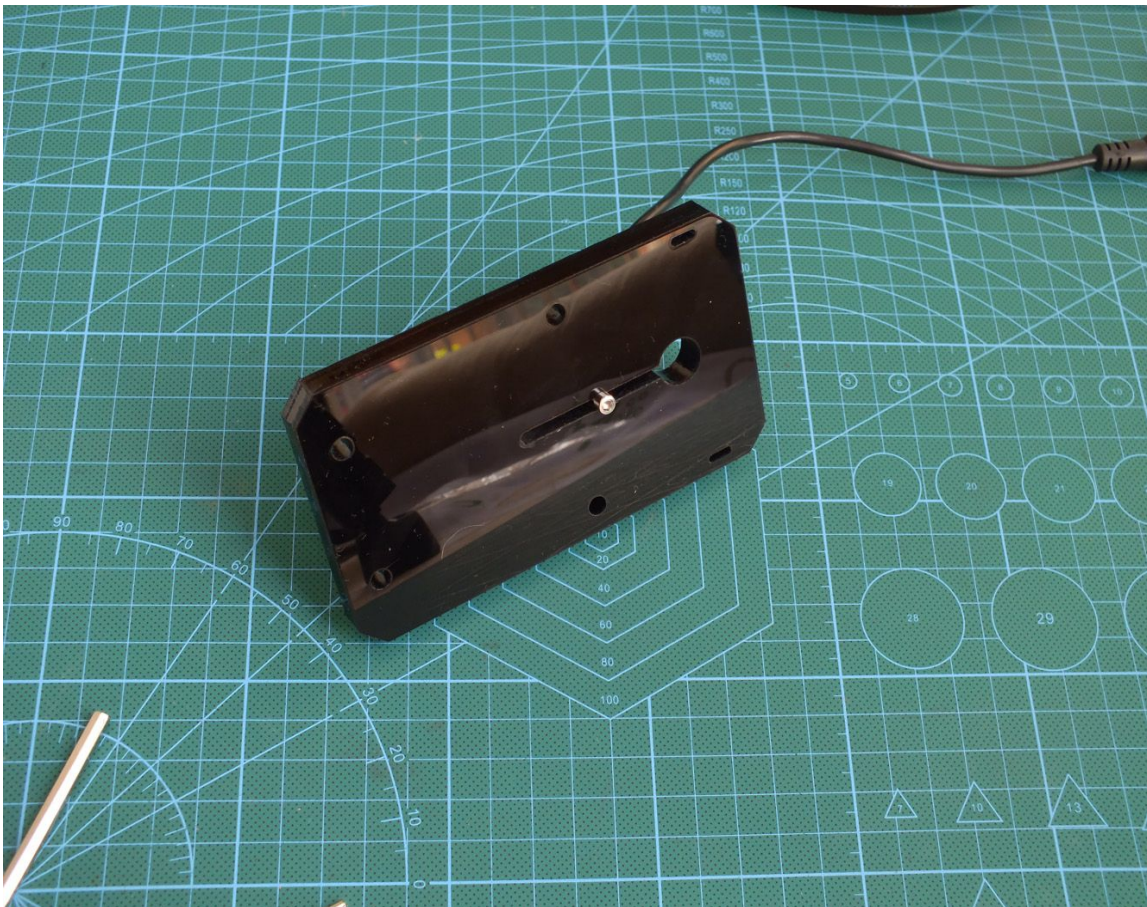

Sagaon

9.-



10.-

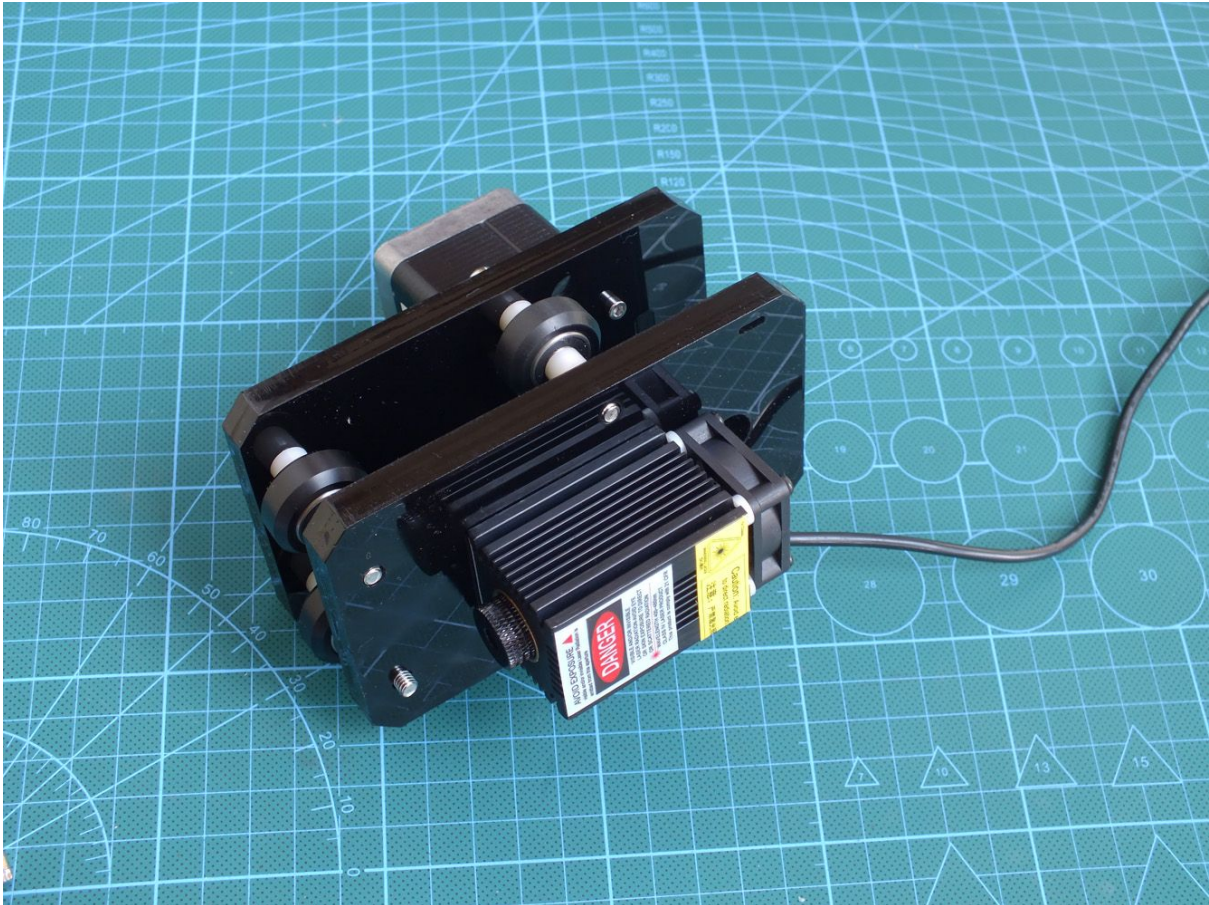

Sagaon

11.-

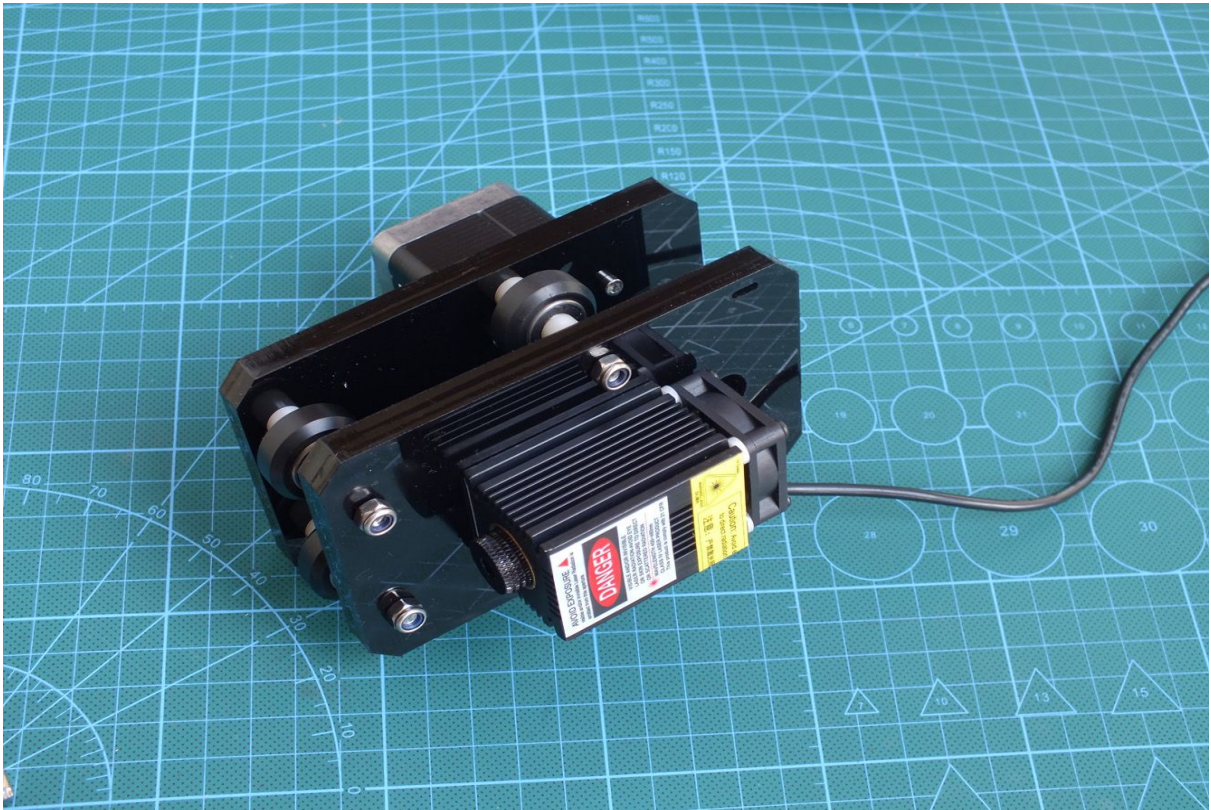

12.-

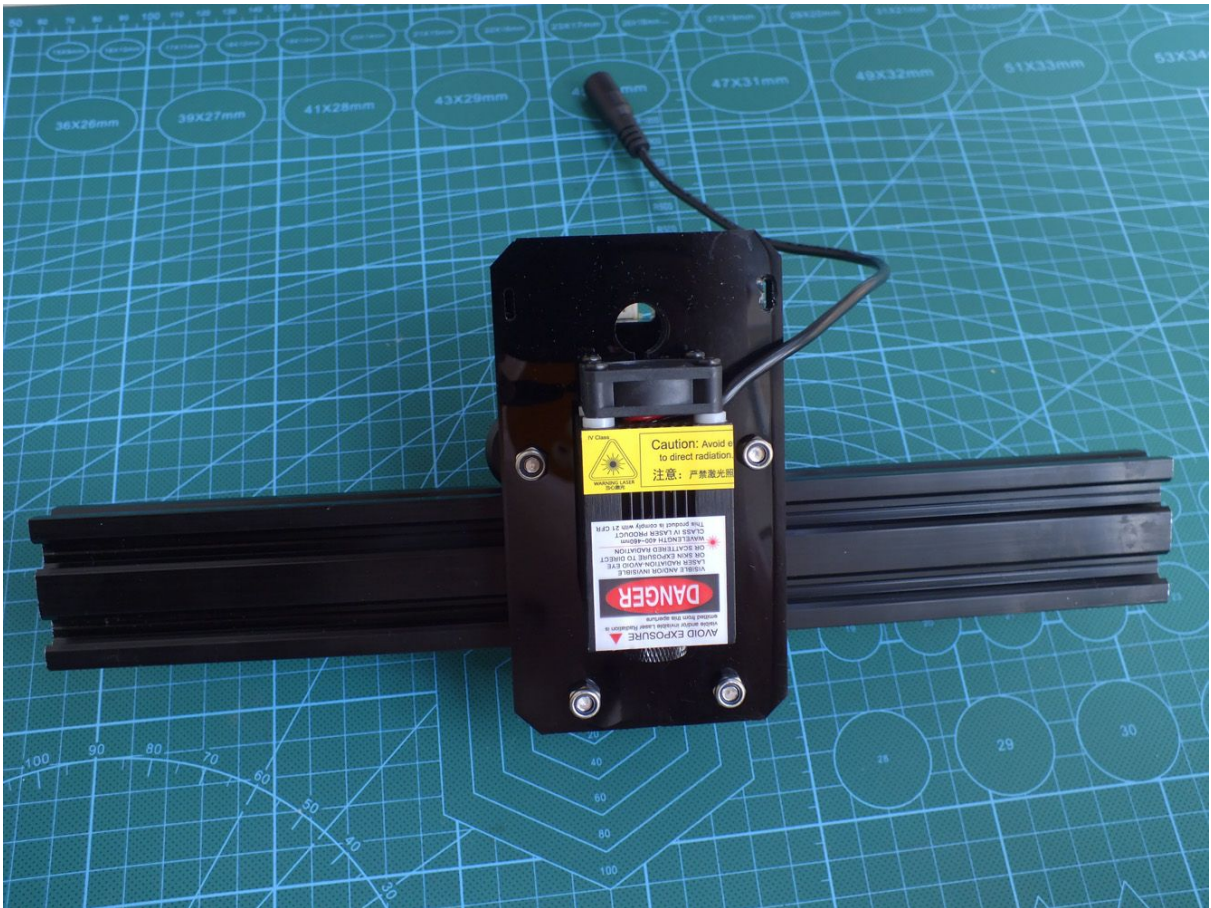

13.-

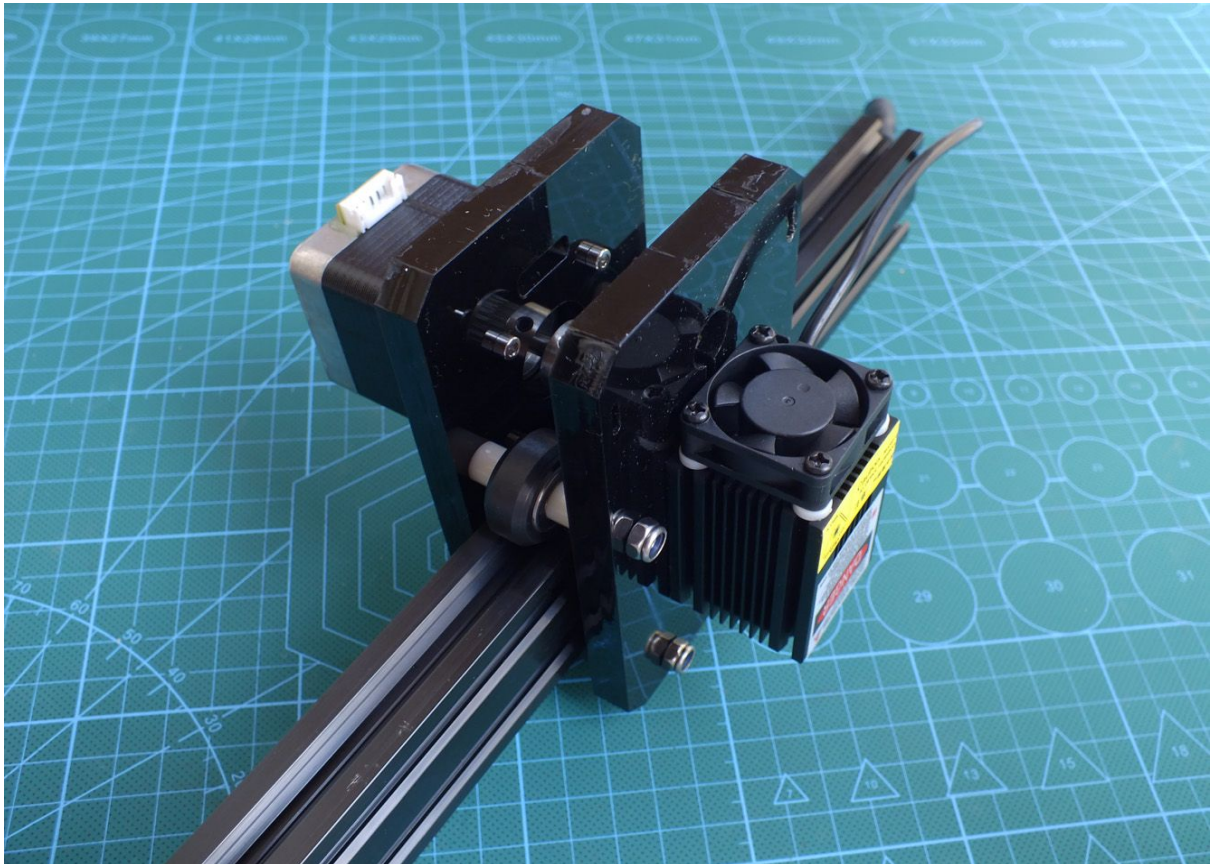

Paso 4: Ajuste de bandas en ejes Y & X

1.-

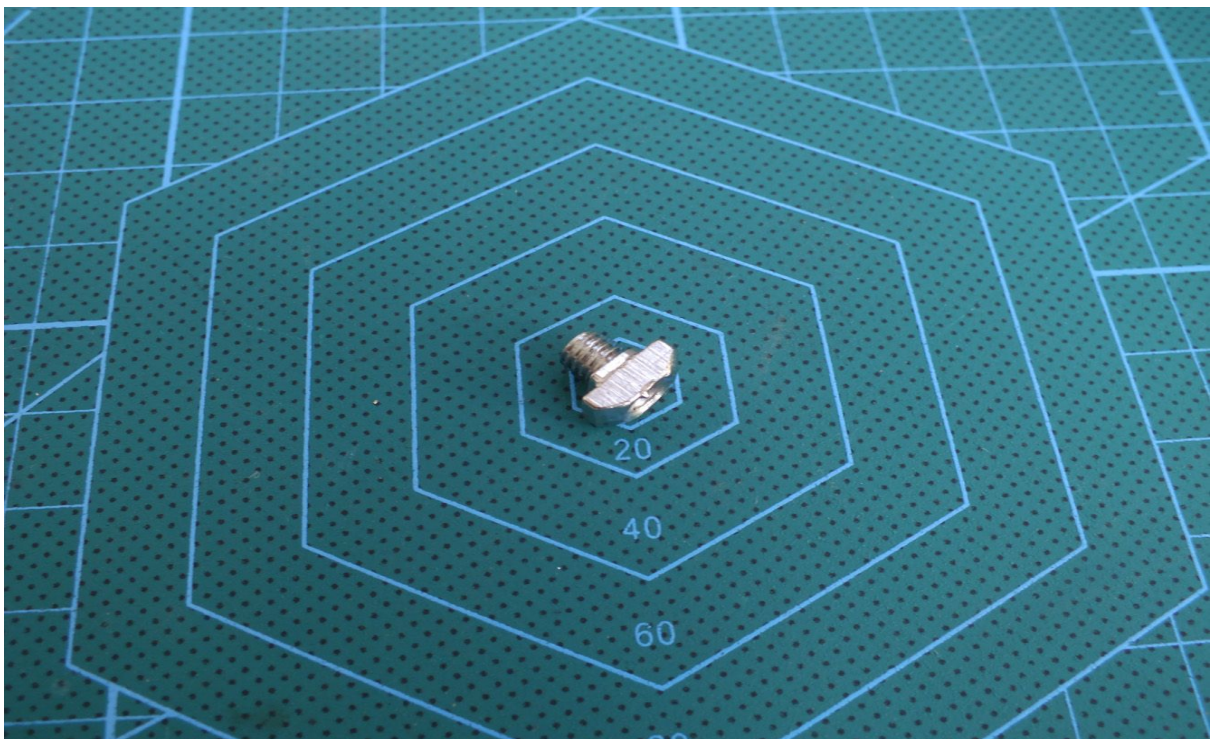

Sagaon

2.-

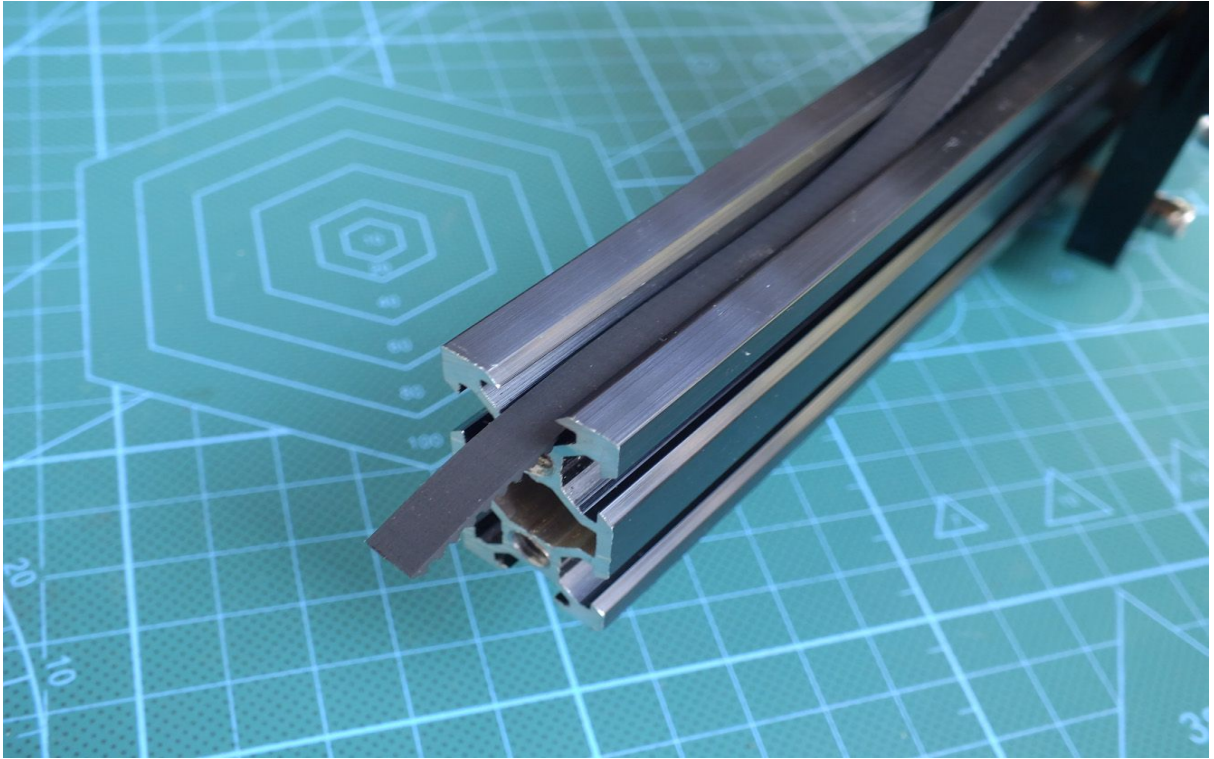

3.-

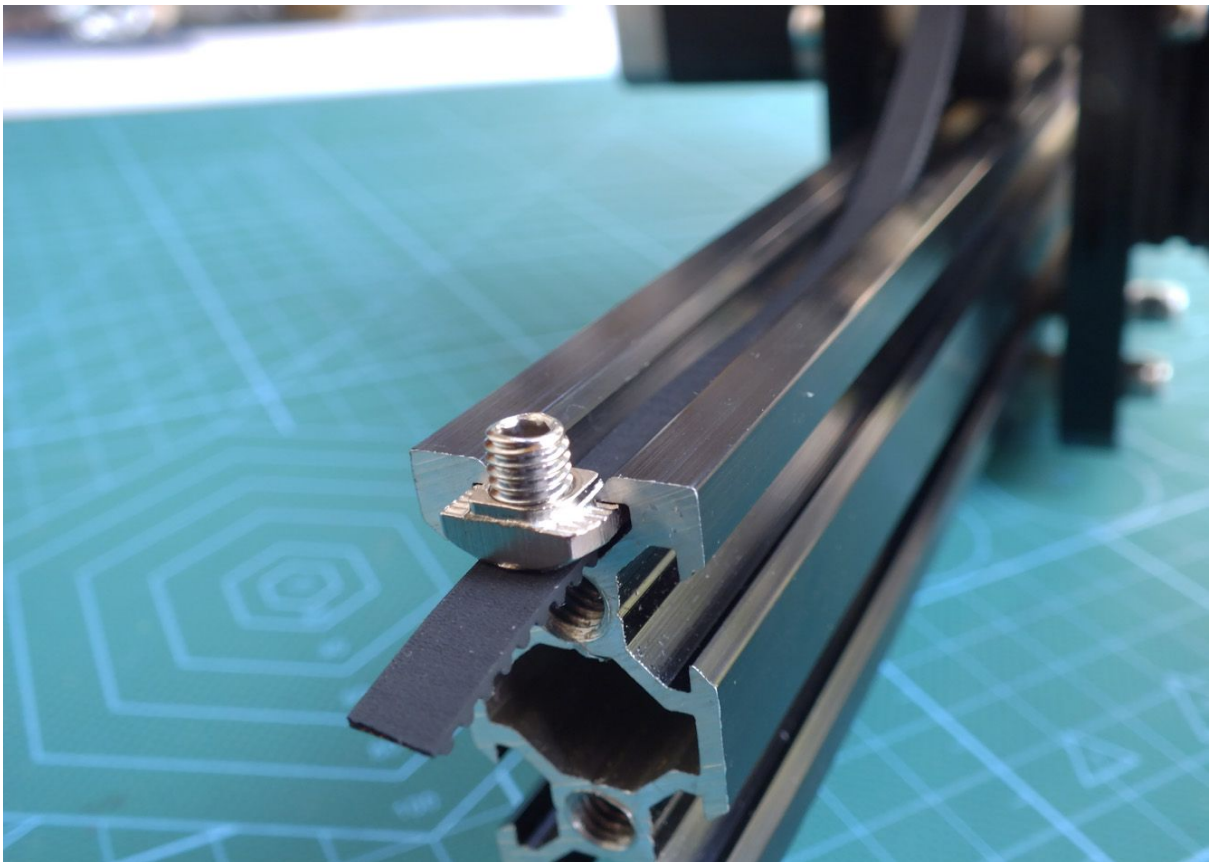

Sagaon

4.-

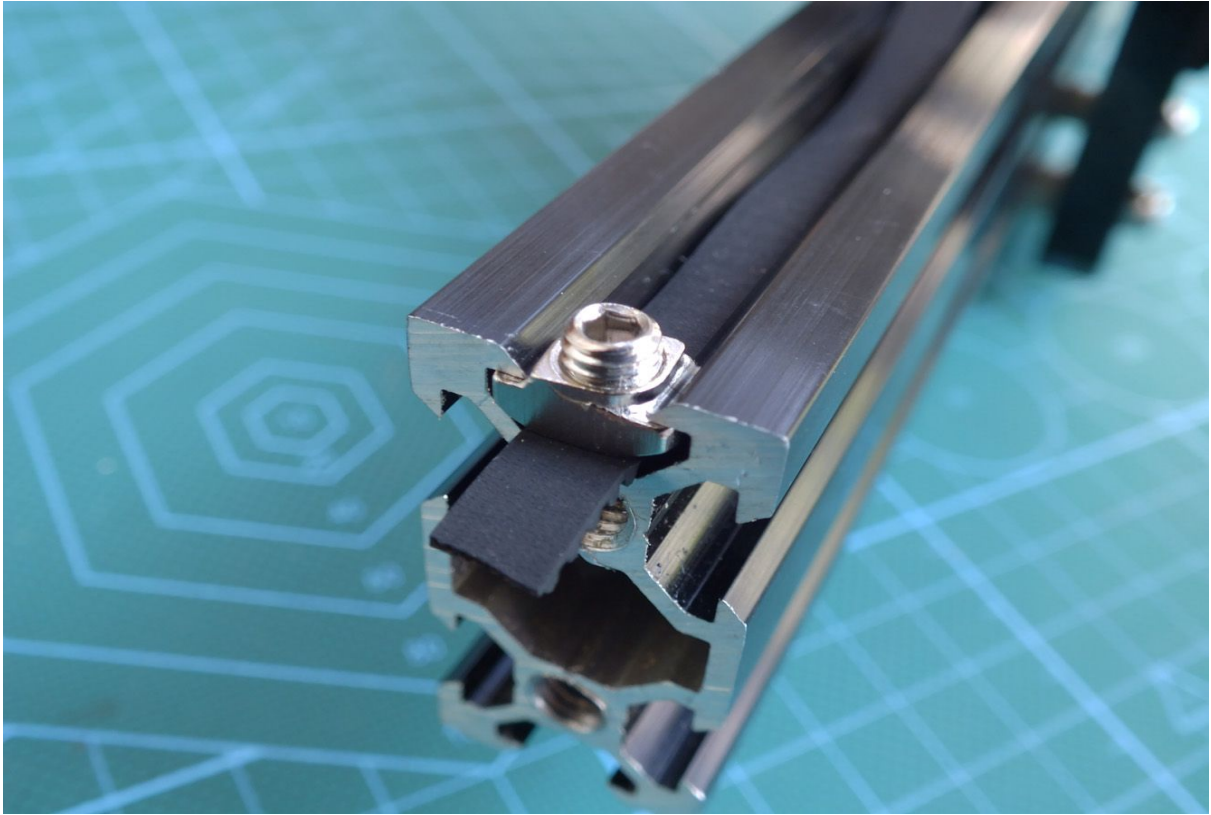

5.-

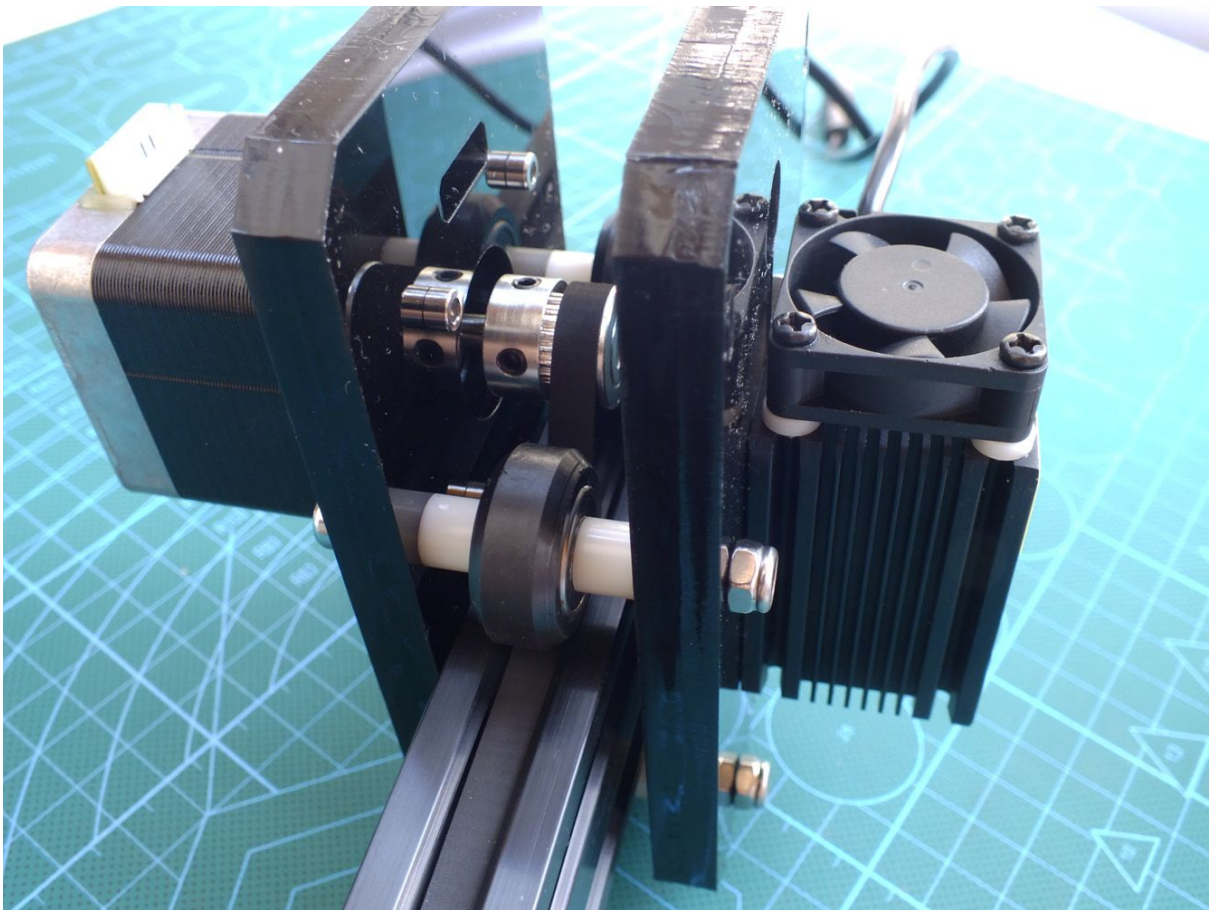

Sagaon

6.-

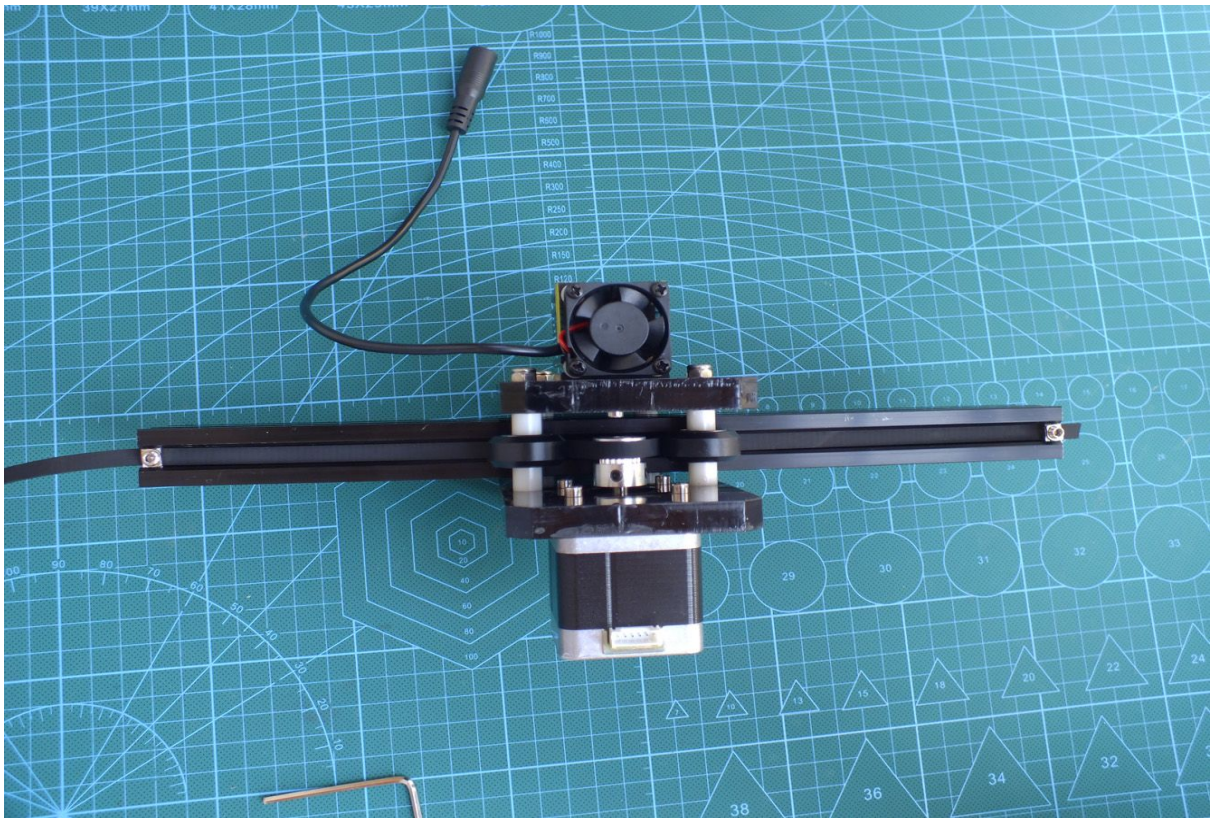

7.-

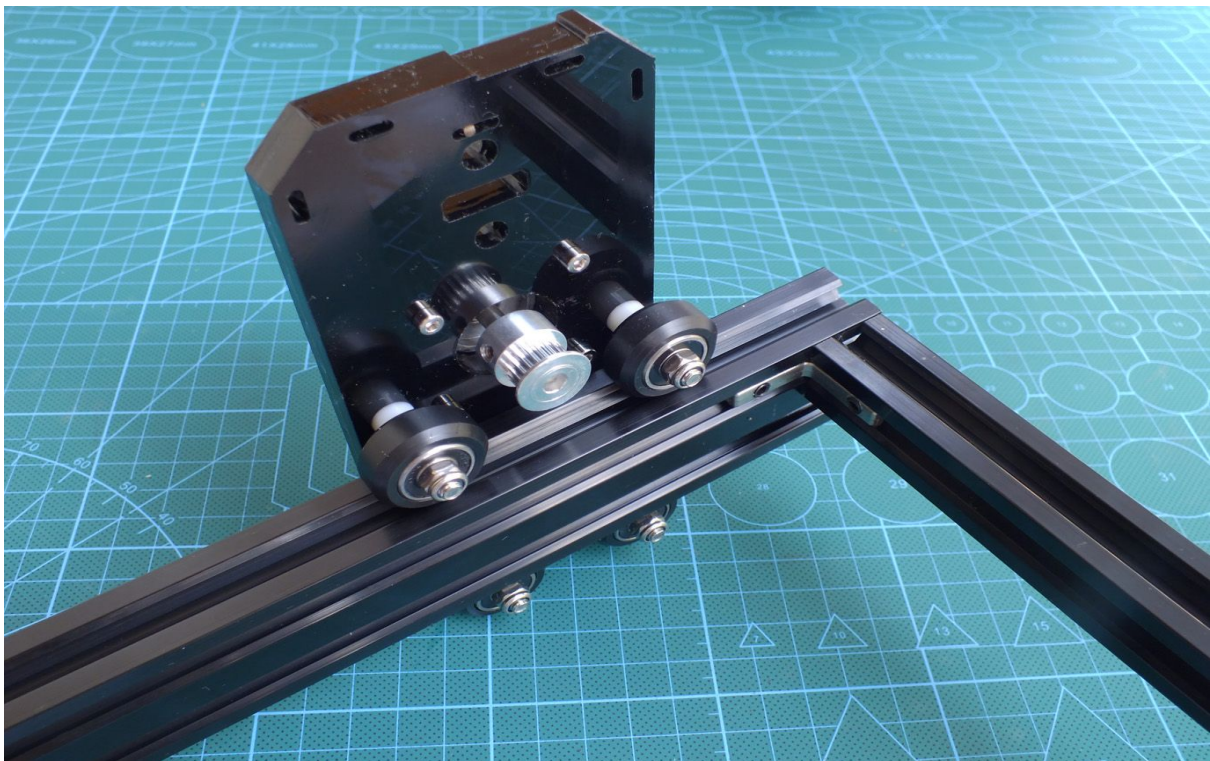

Sagaon

8.-

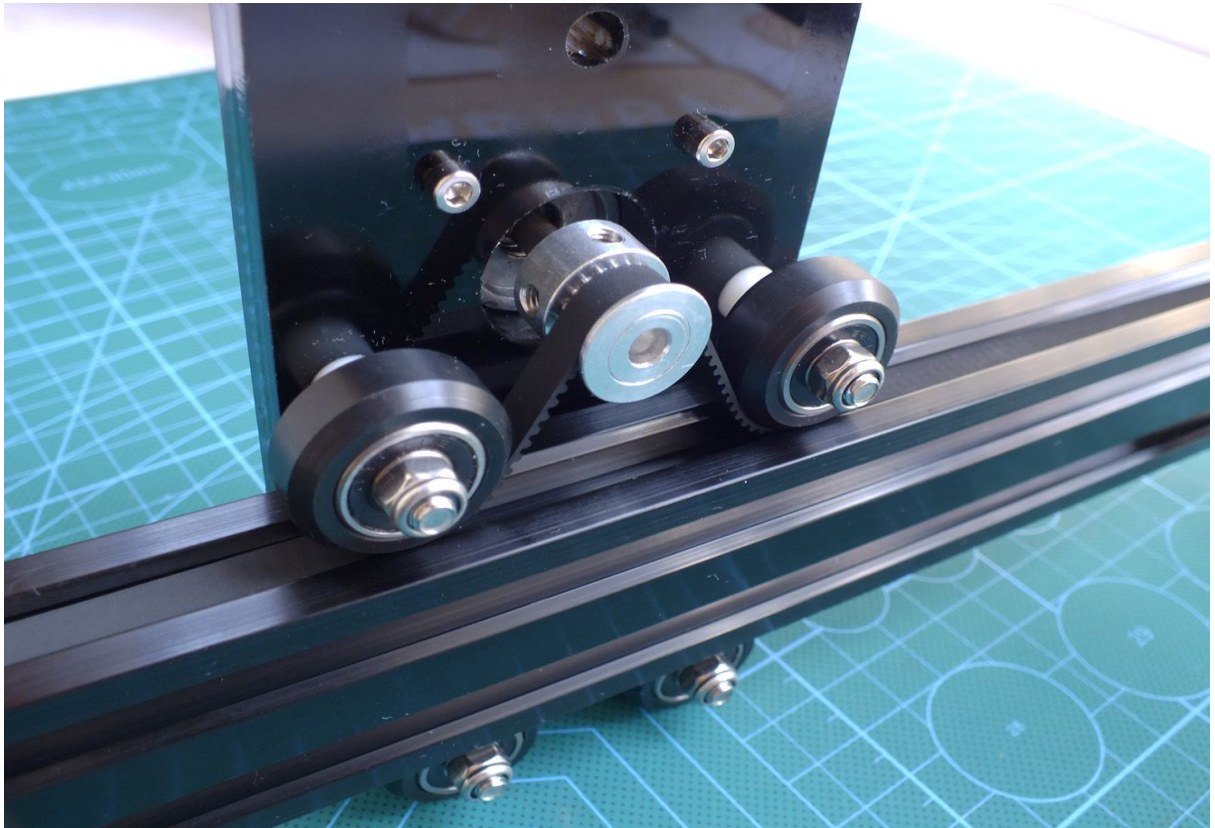

9.-

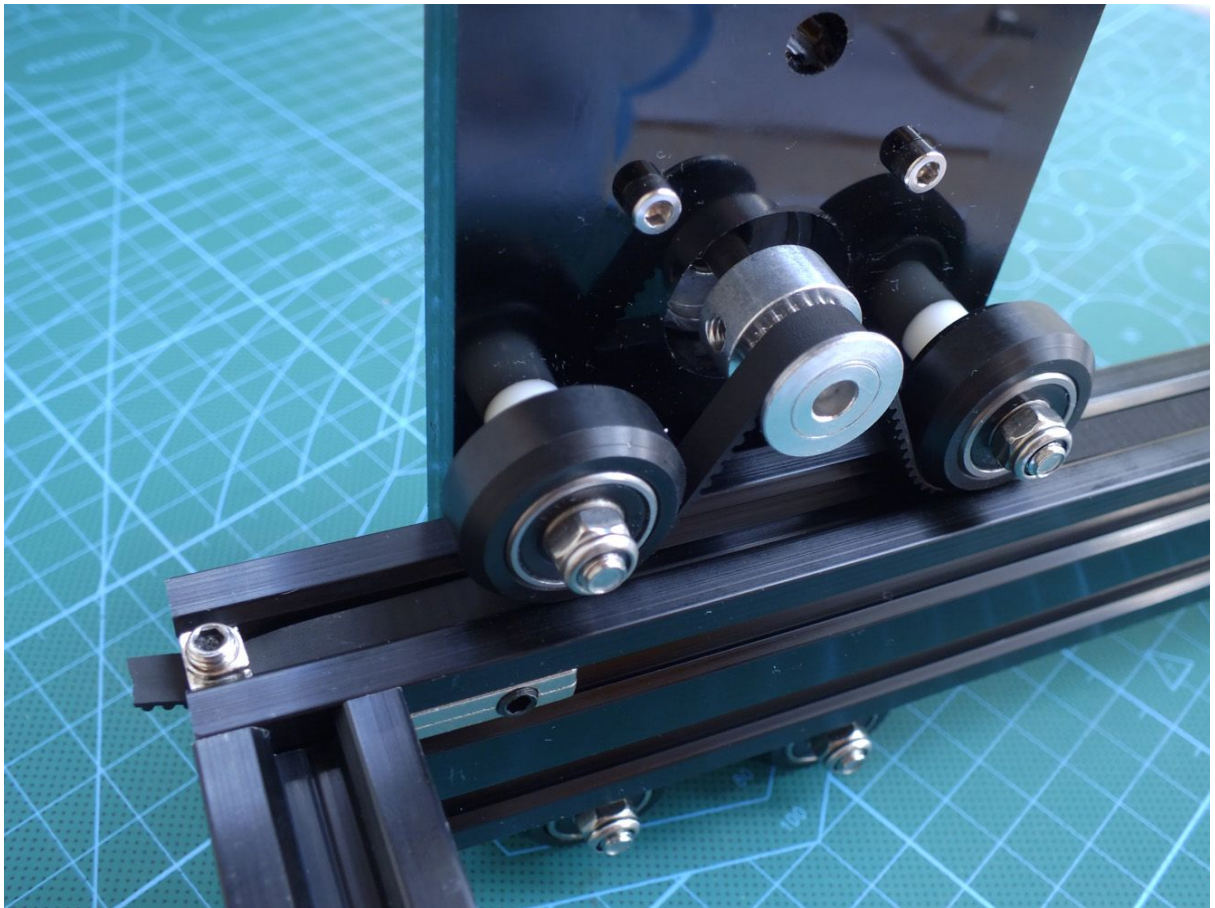

Sagaon

10.-

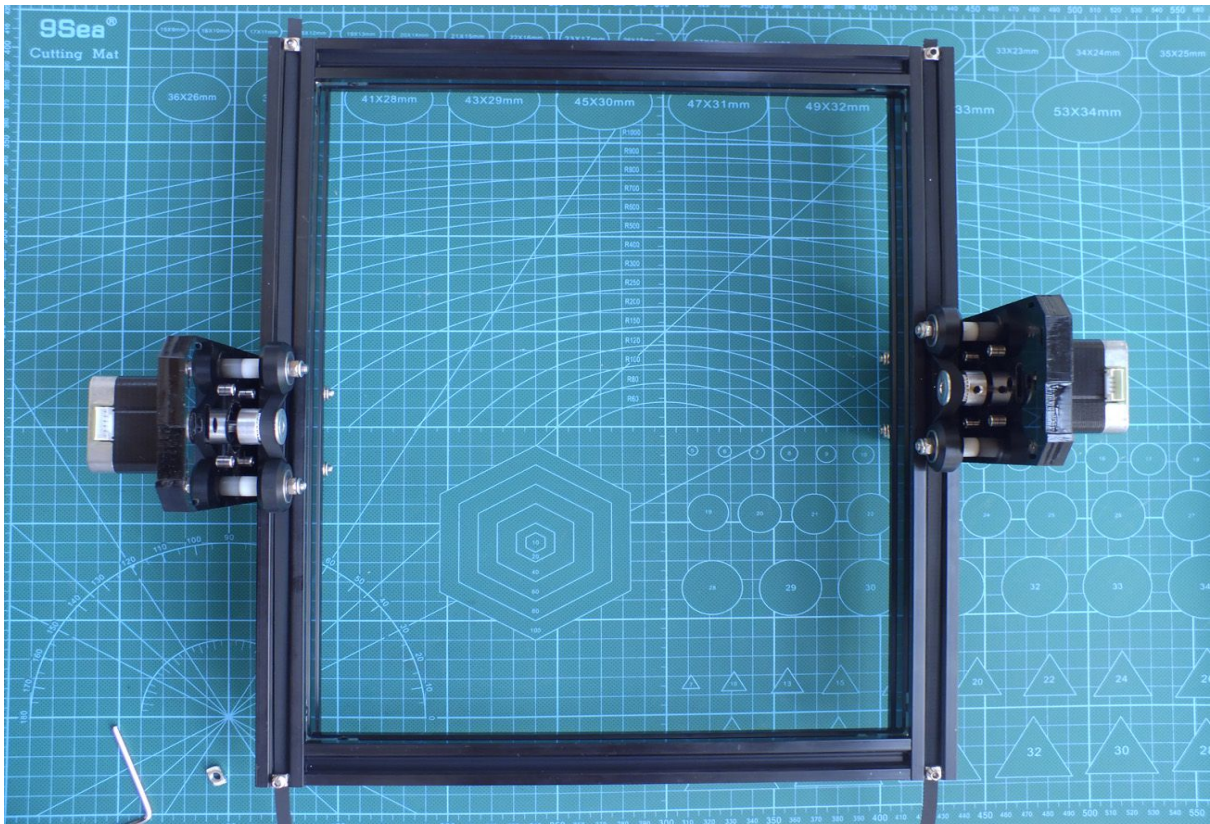

11.-

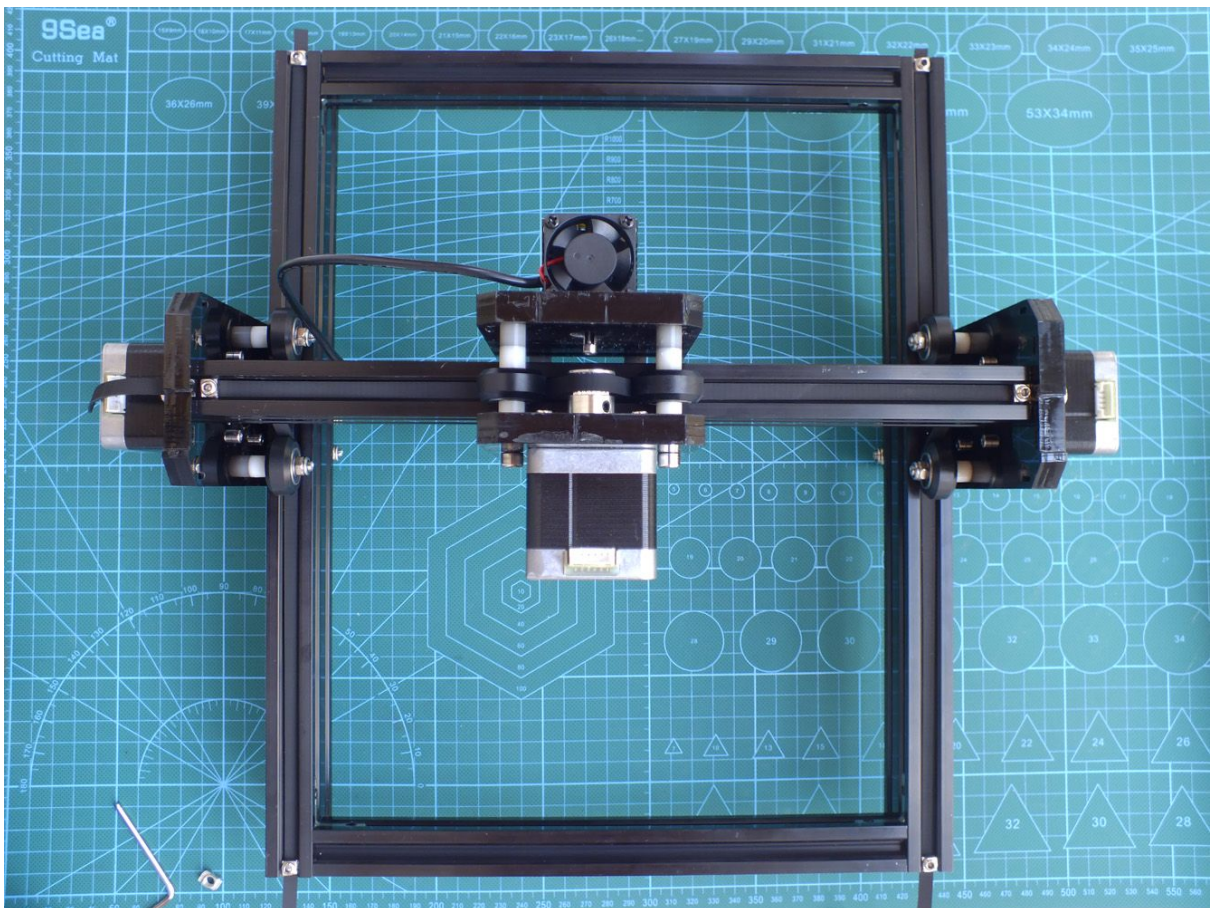

12.-

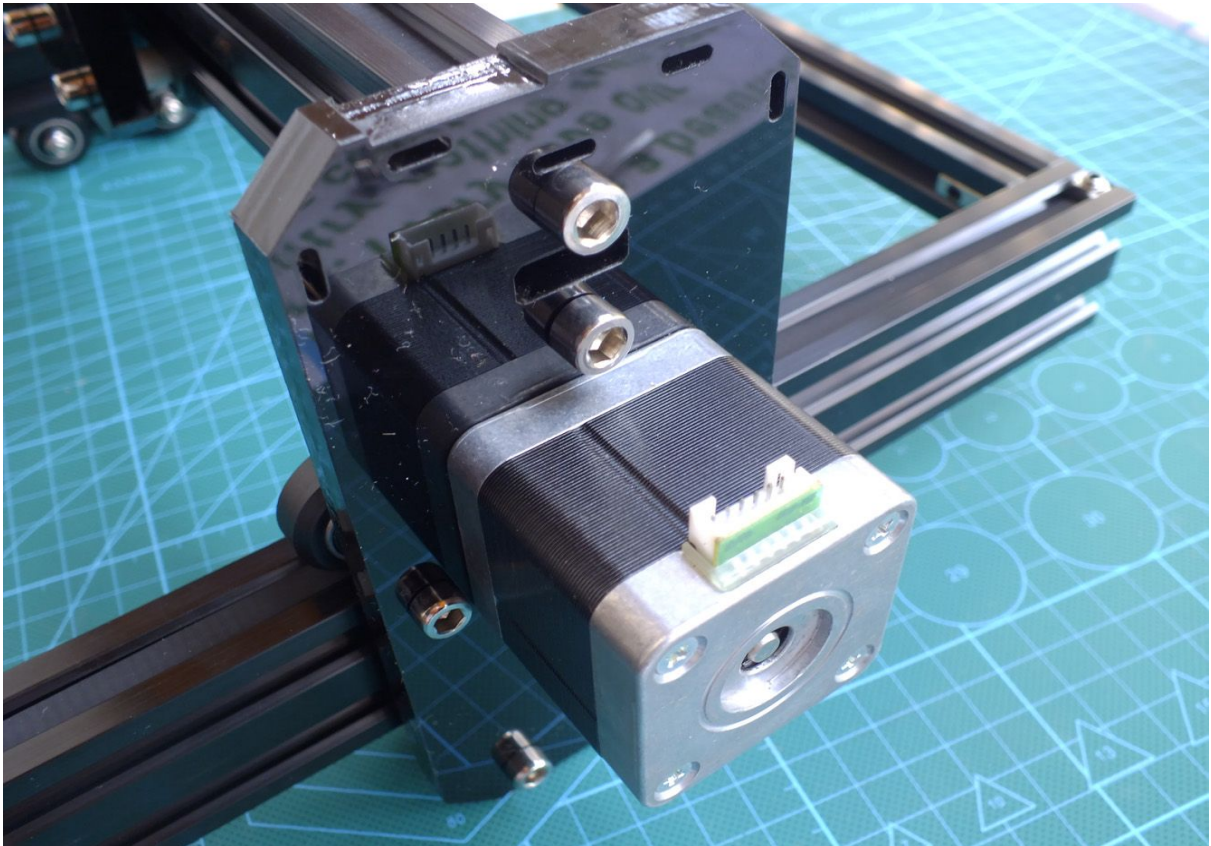

Paso 5: Ajuste placa de control

1.-

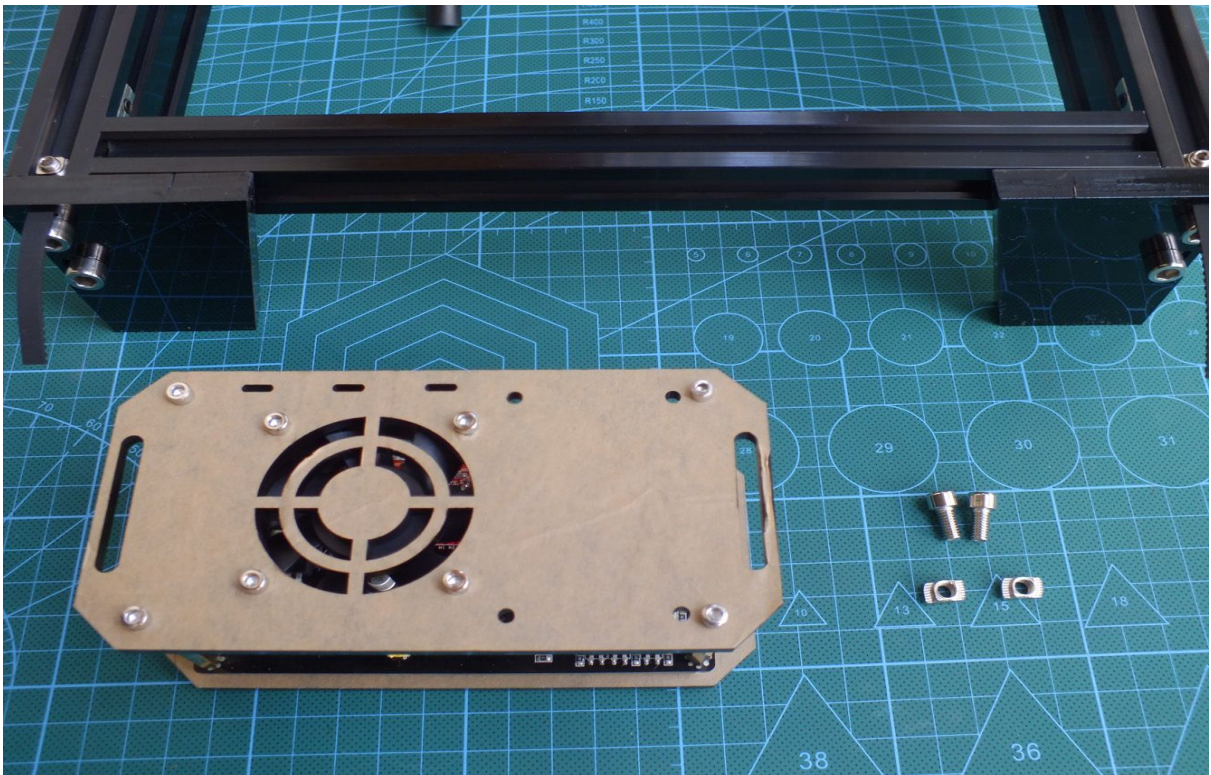

Sagaon

2.-

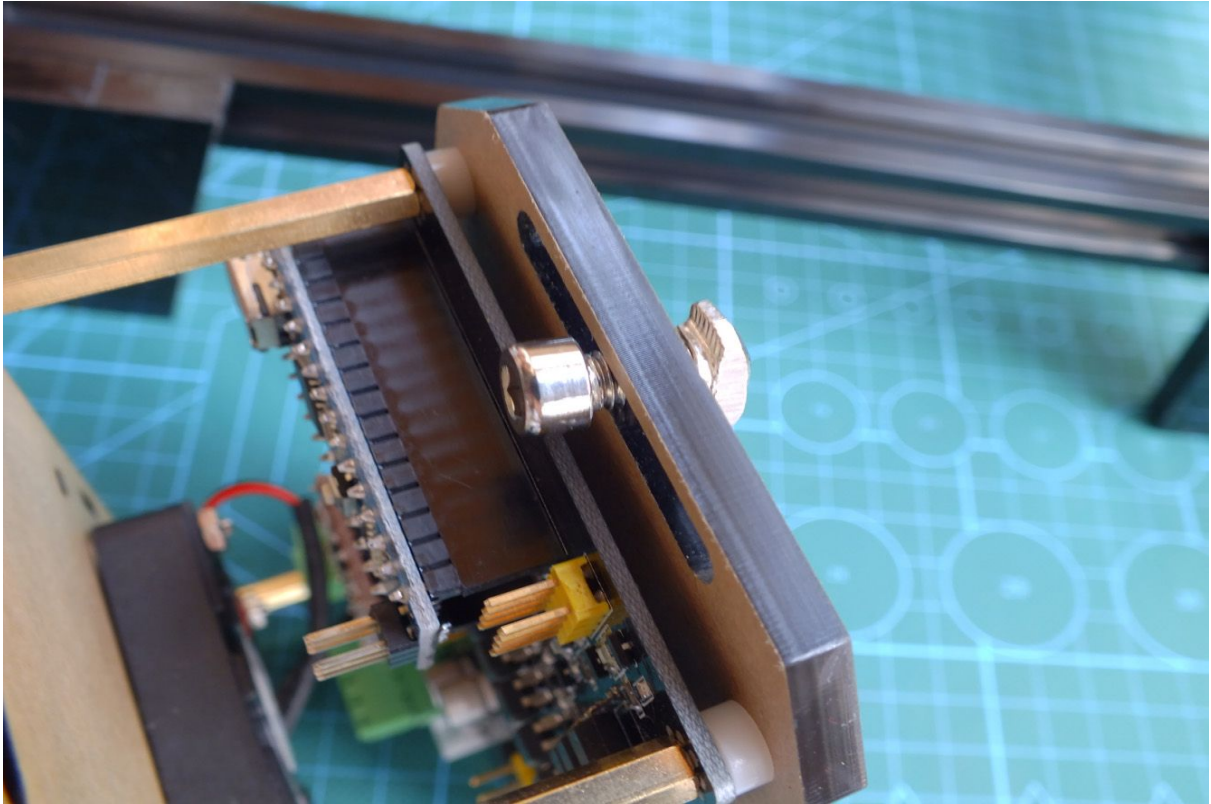

3.-

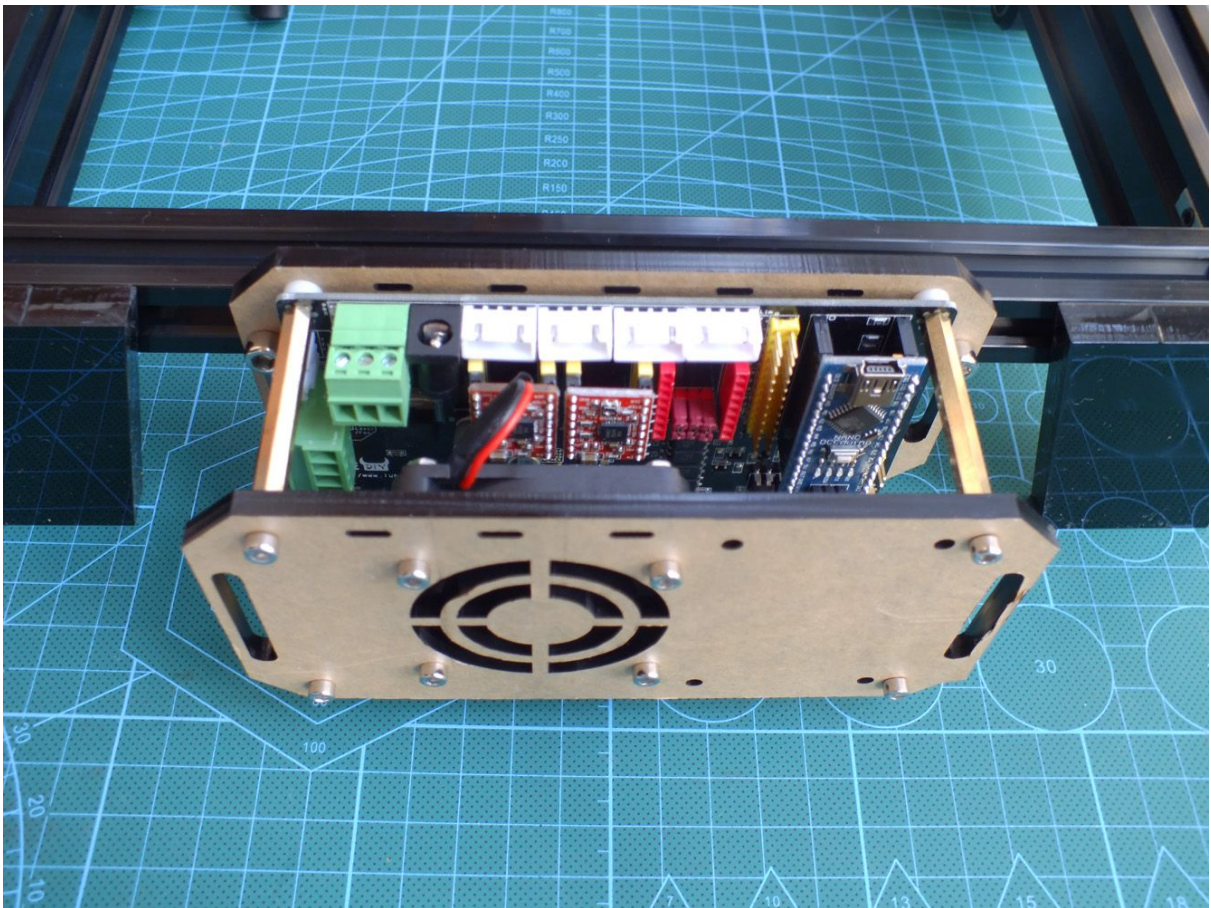

Sagaon

Paso 6: Ensamble motores, láser y esquineros

1.-

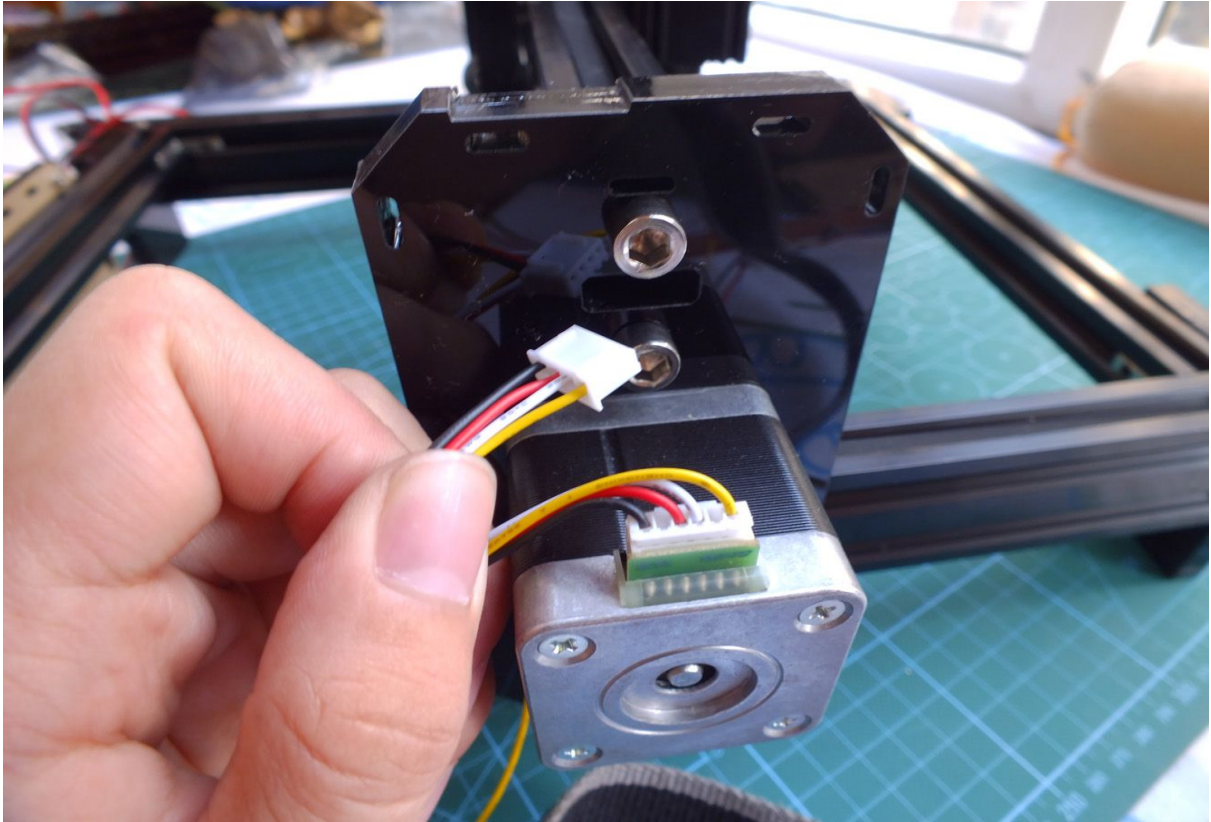

2.-

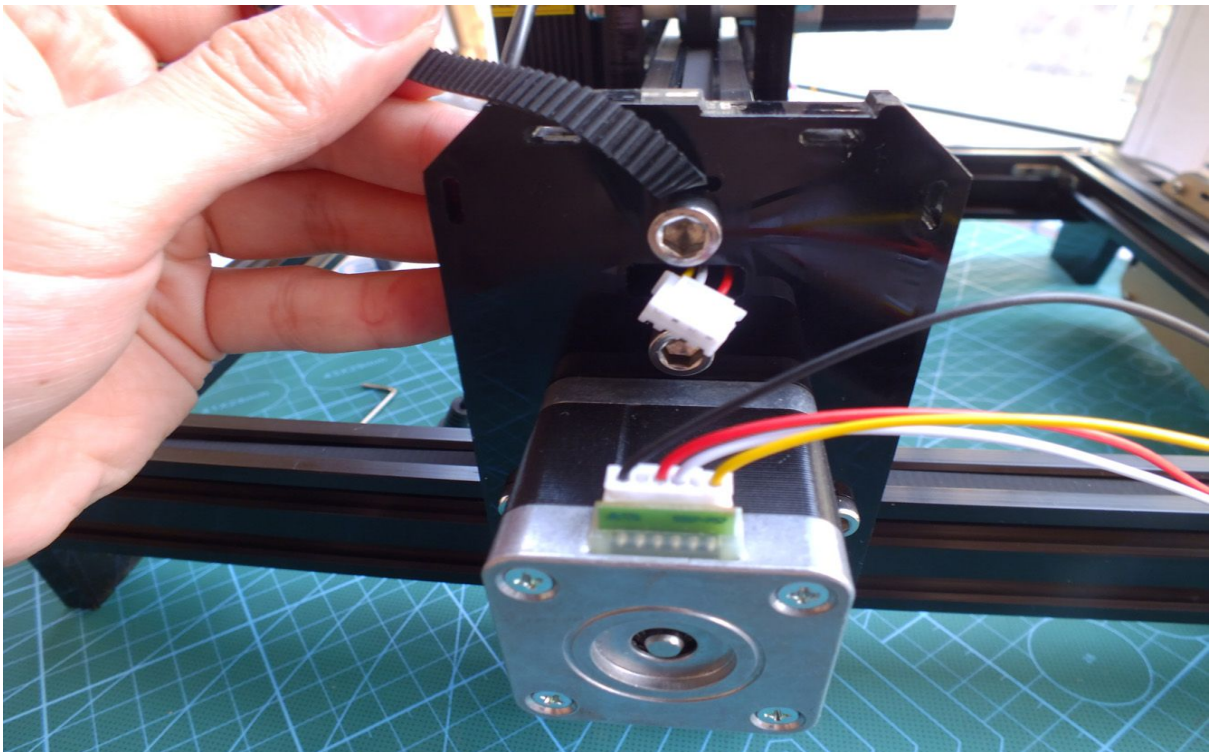

Sagaon

3.-

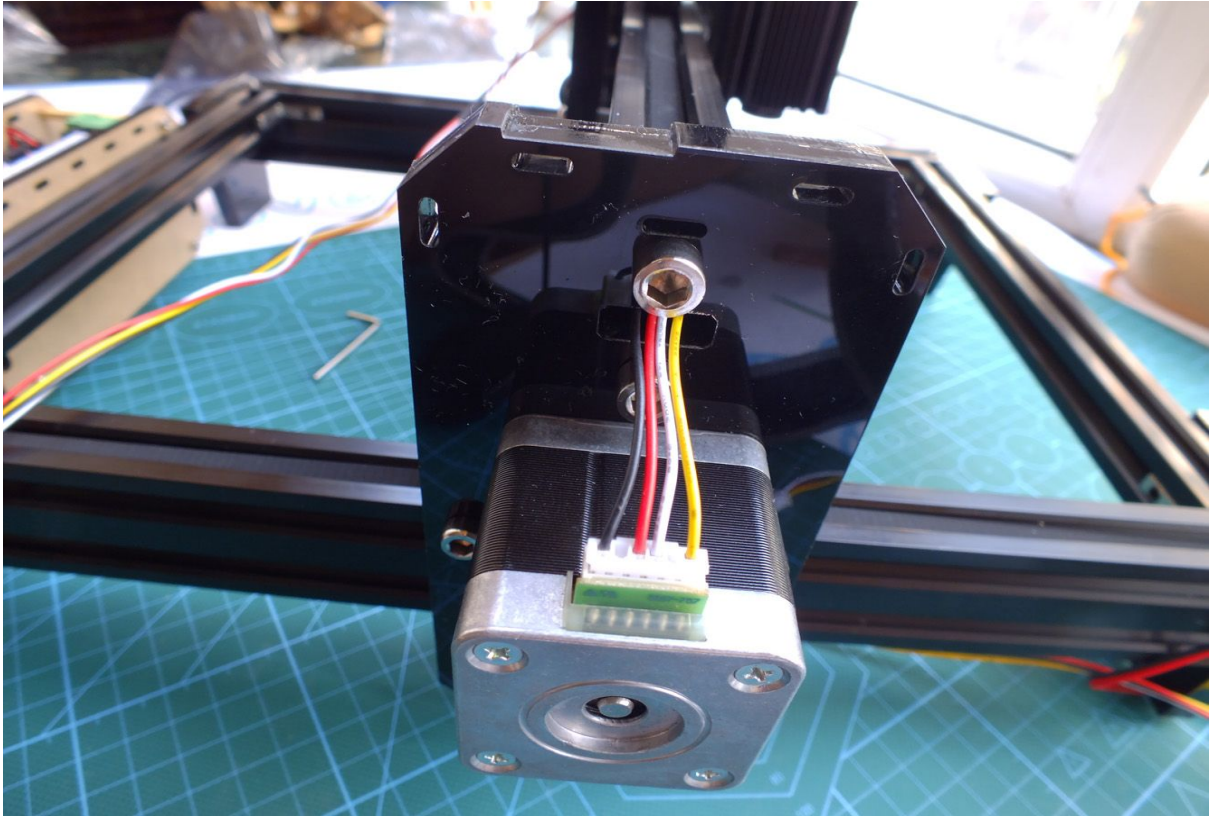

4.-

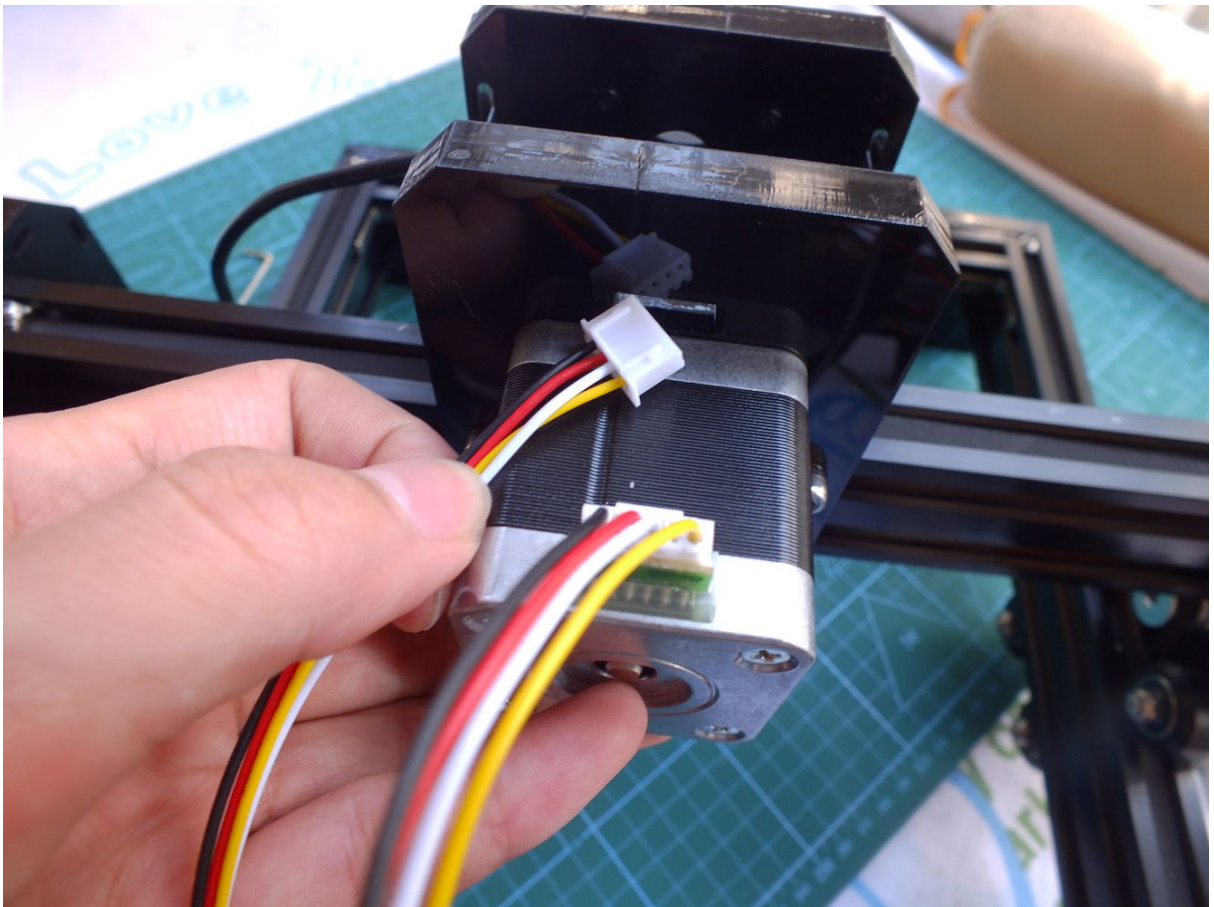

Sagaon

5.-

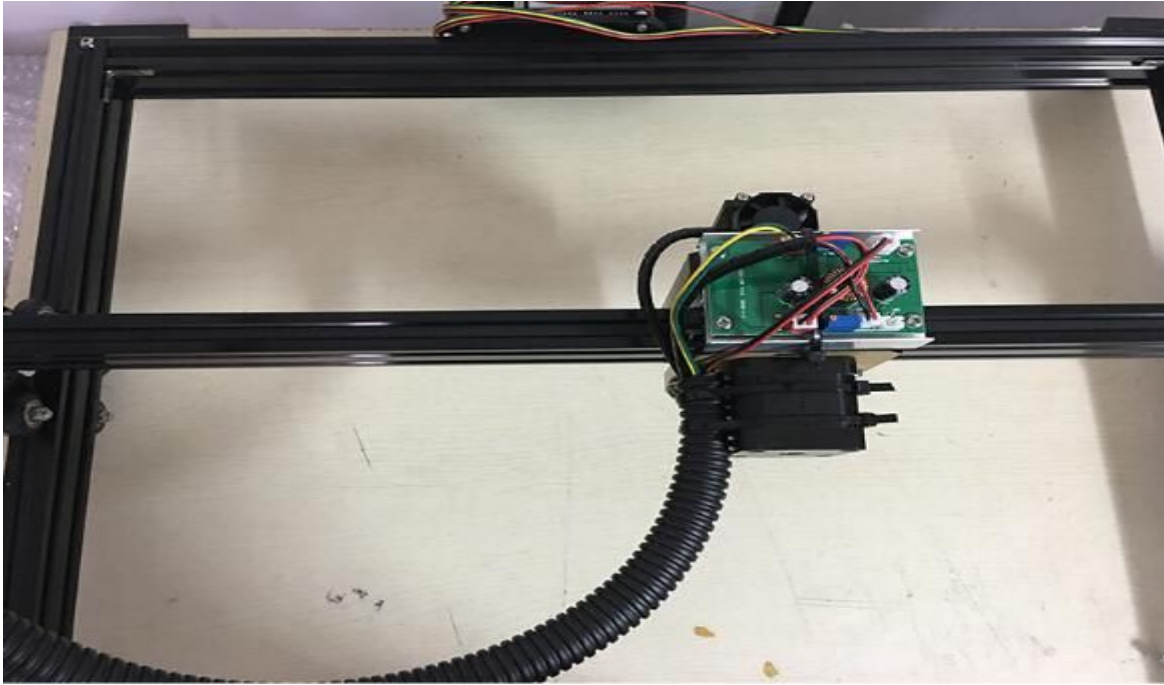

5.1.-

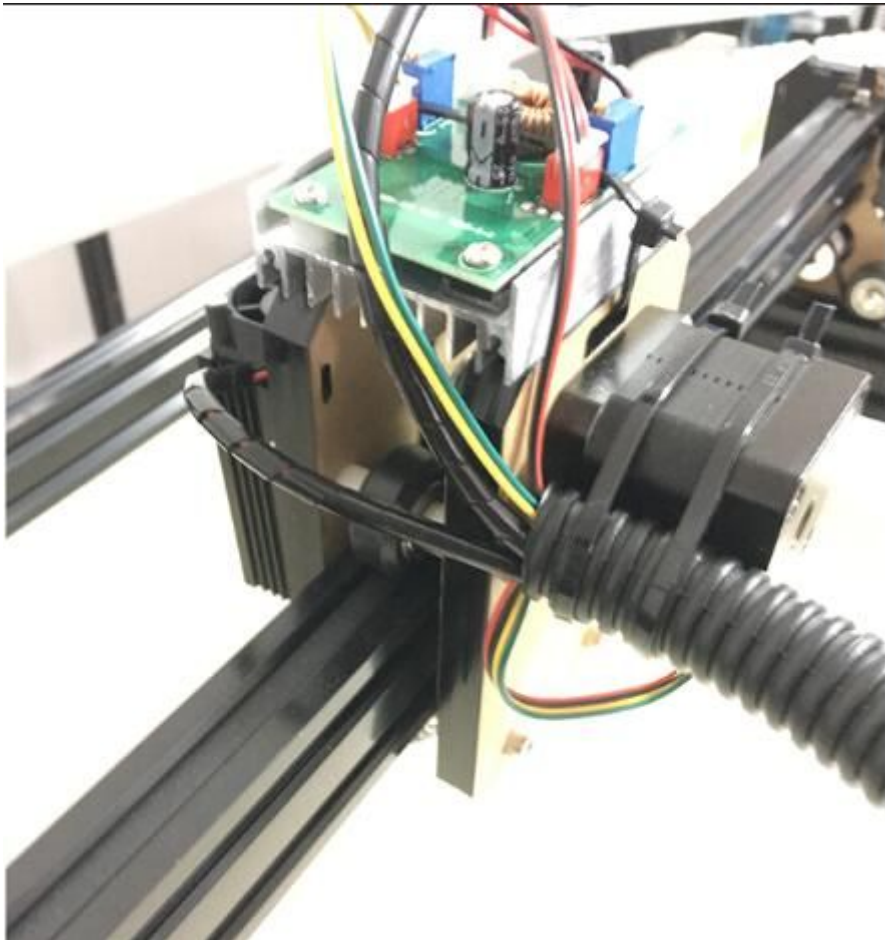

Sagaon

5.1.1

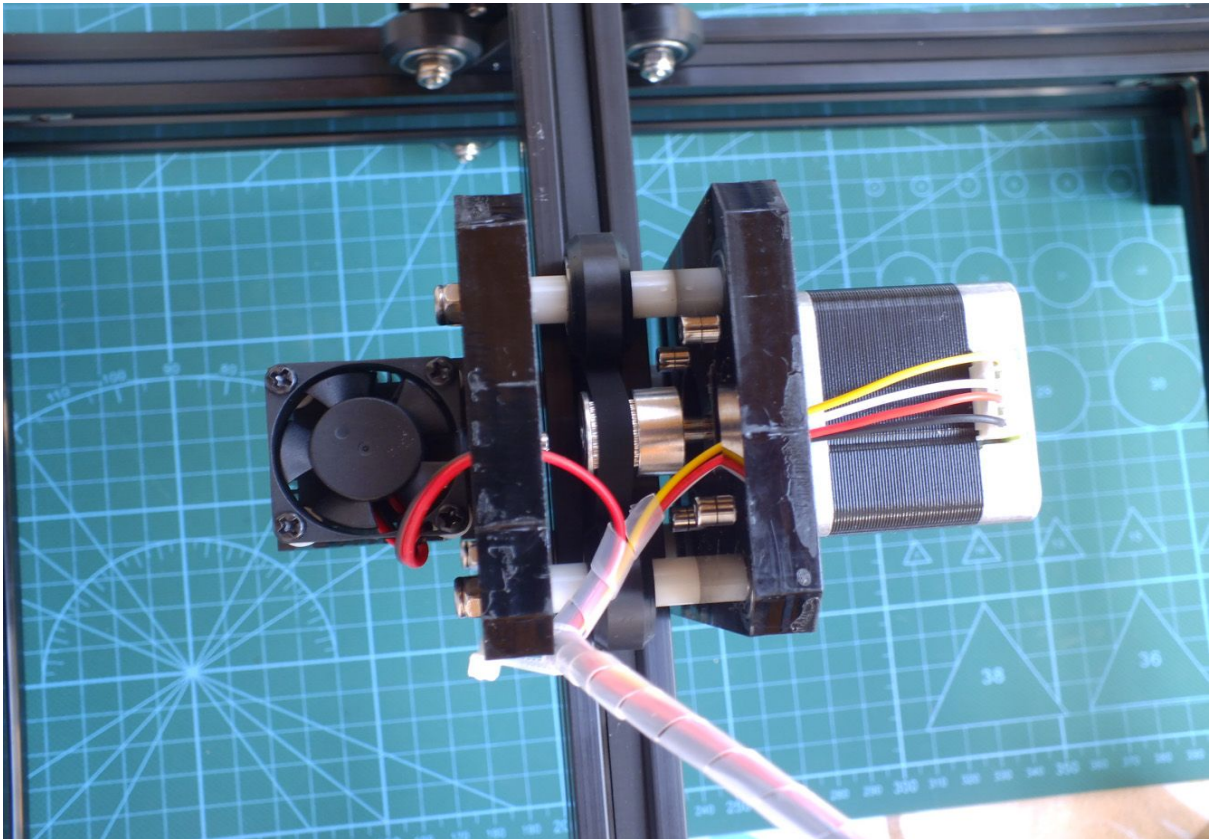

6.-

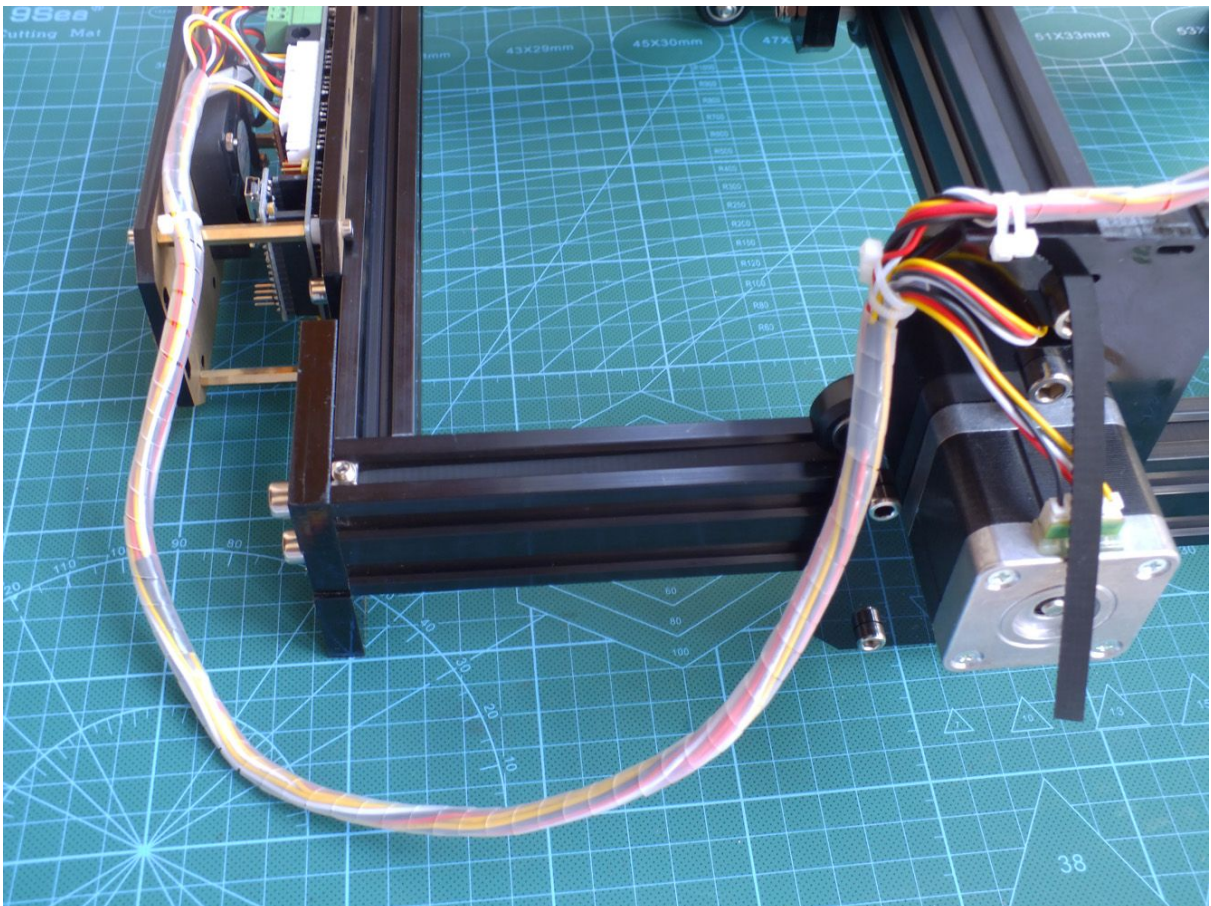

Sagaon

7.-

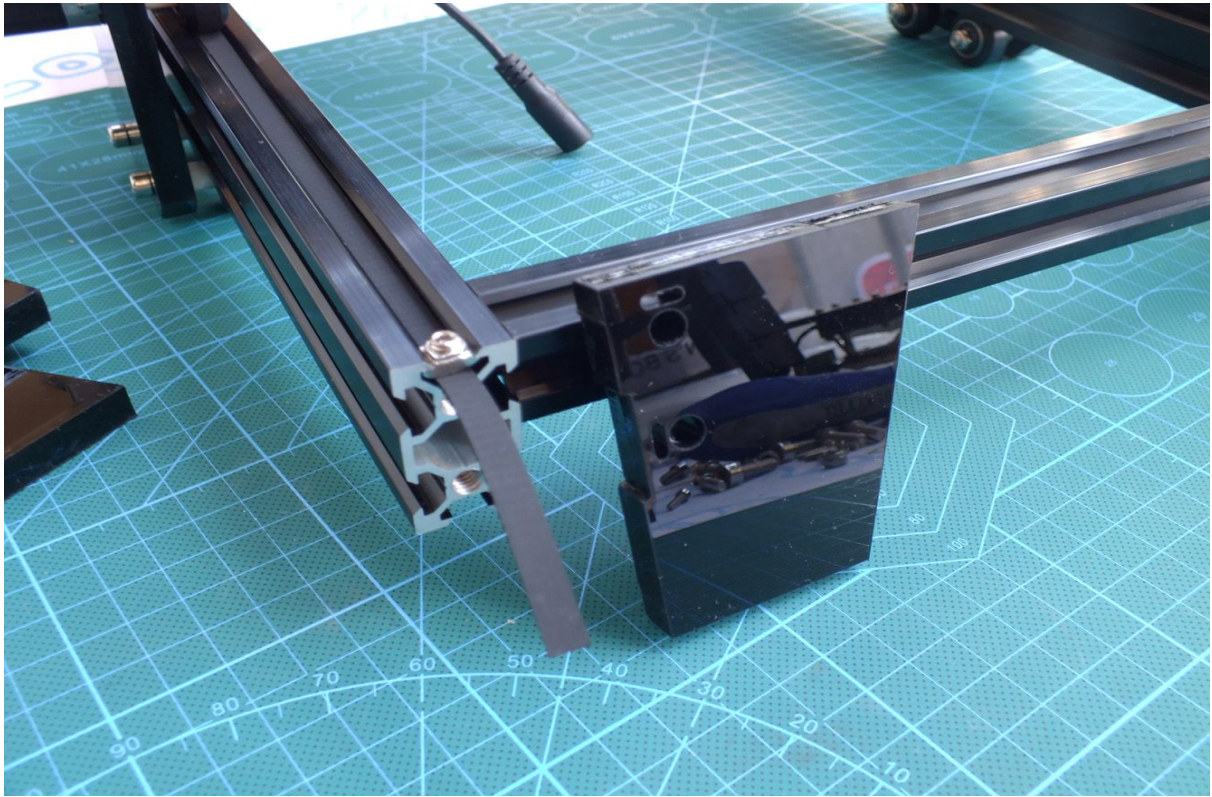

8.-

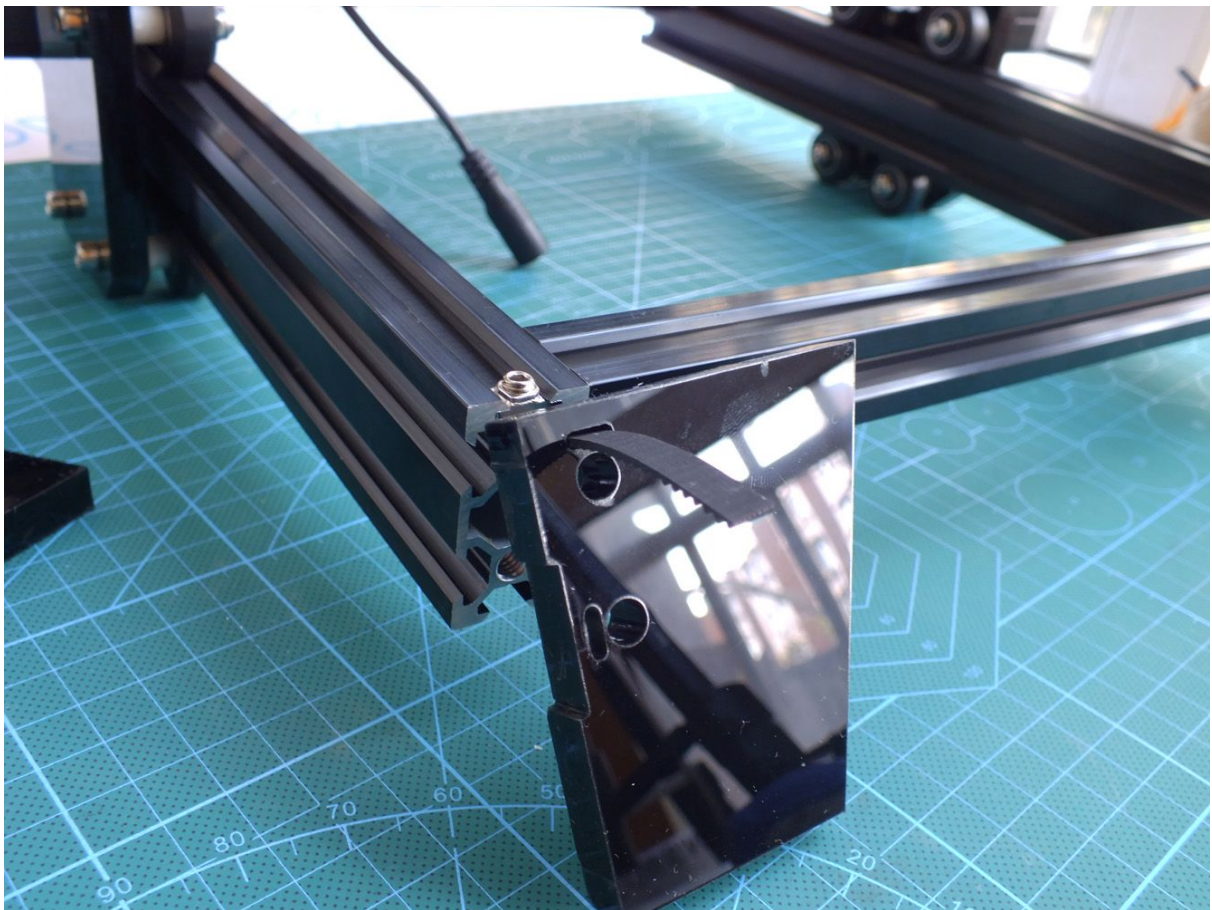

Sagaon

9.-

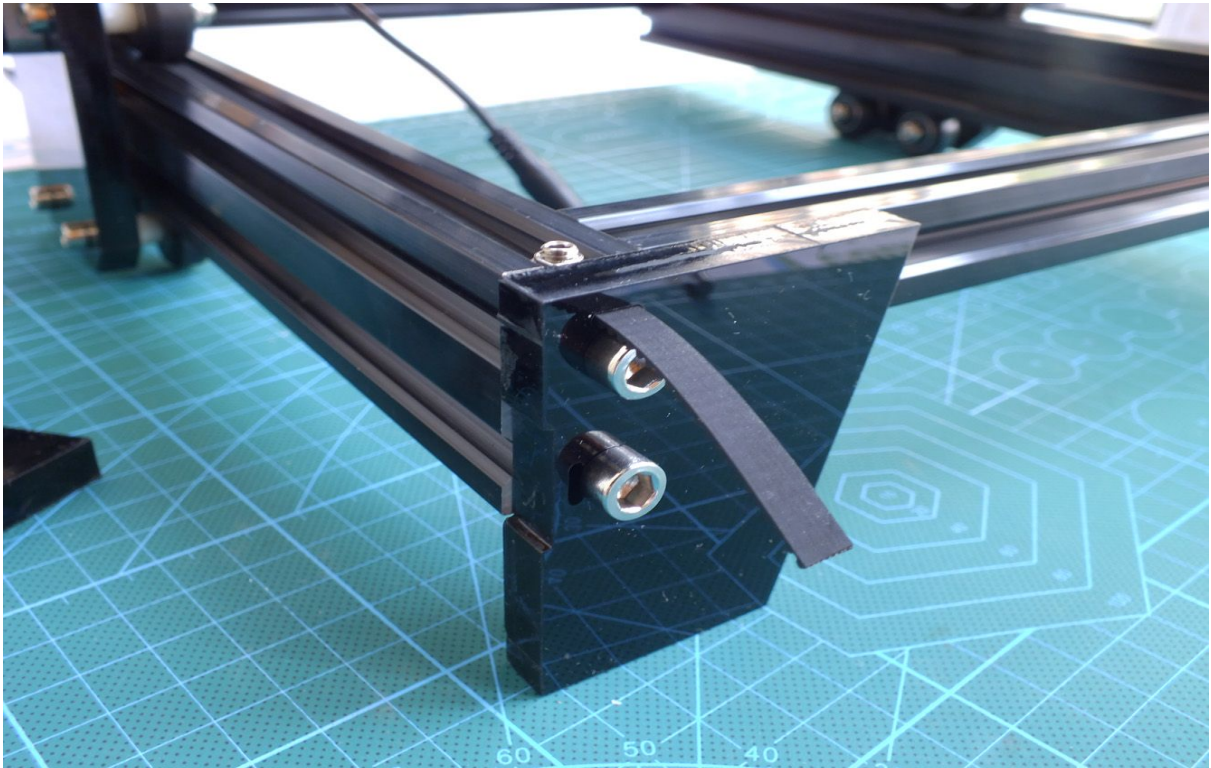

10.-

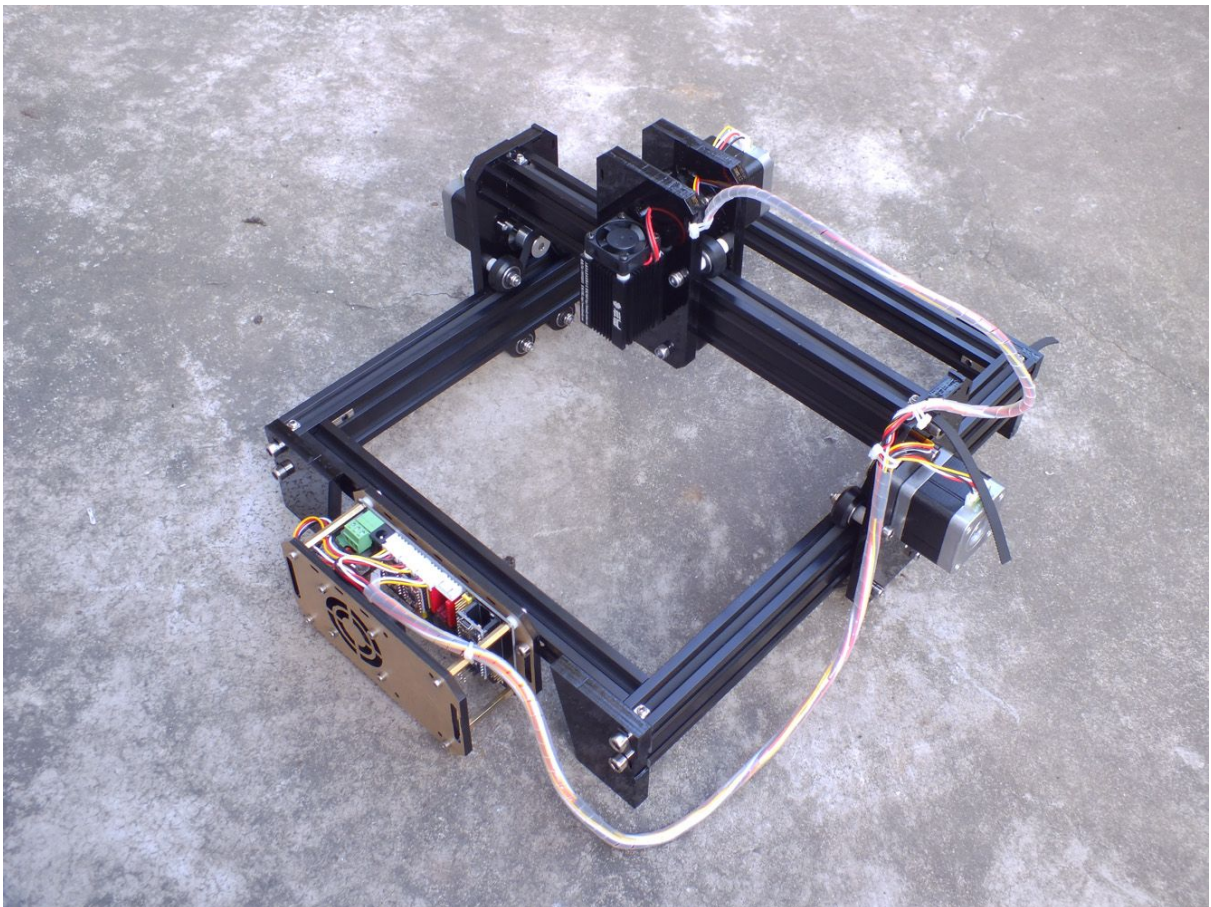

Paso 7: Conexión de Láser

1.- Laser 7w

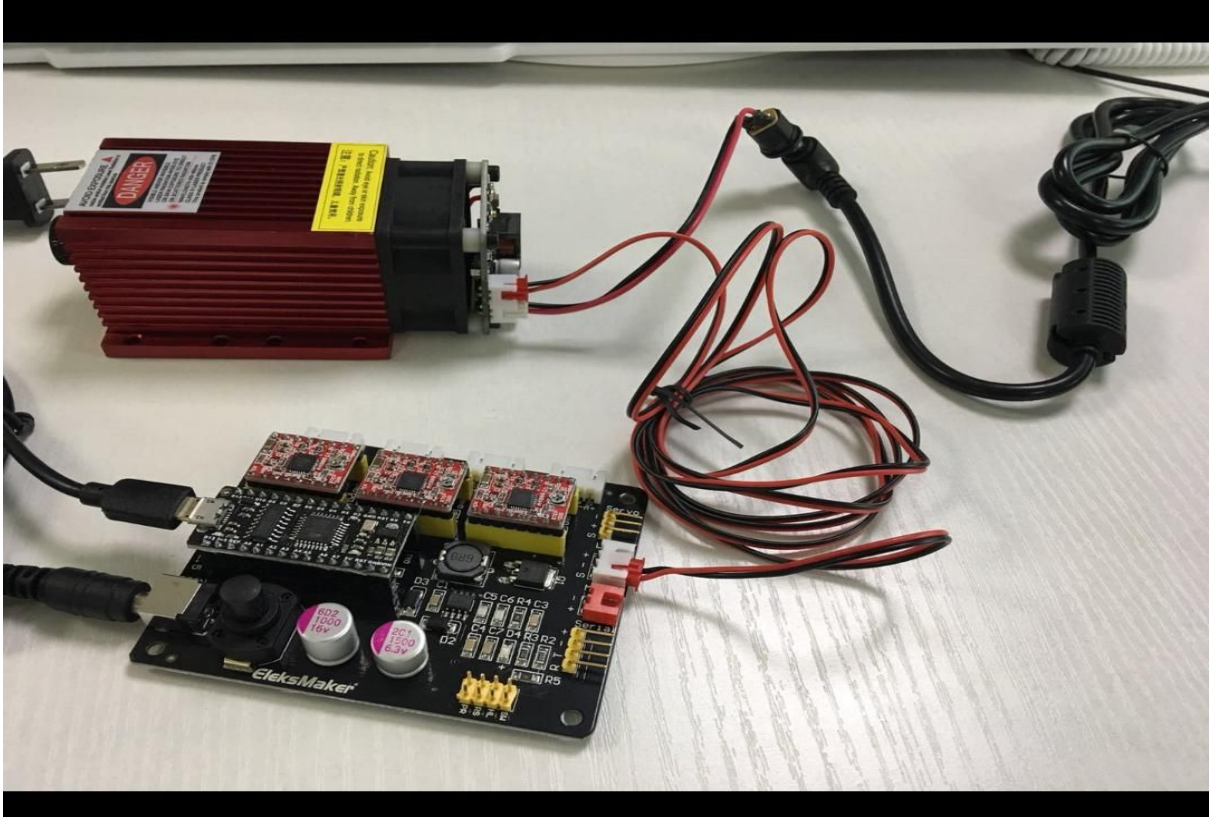

2.- Laser 15w

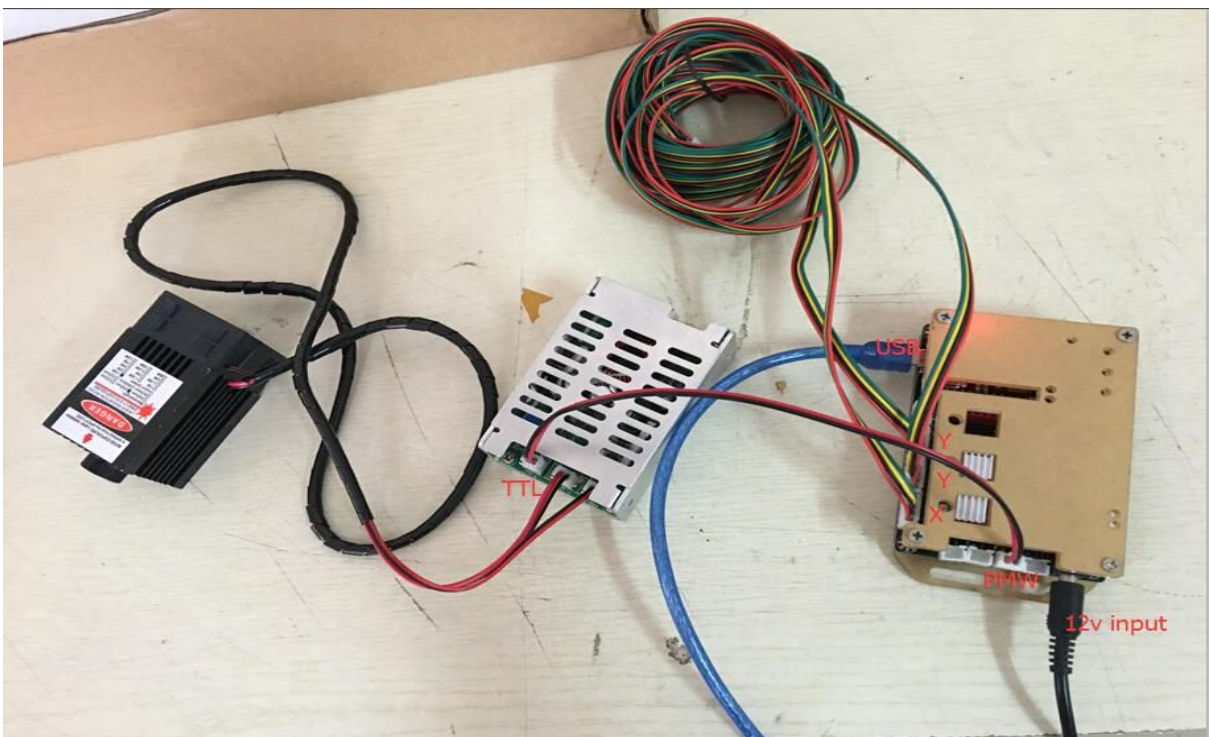

Sagaon

3.-Laser 5.5w

