

BAKFIRE

User Guide

— Ranger X3 —



WARNING



RISK OF DEATH OR SERIOUS INJURY

Whenever you ride a board, you risk death or serious injury from loss of control, collision, and falls. To ride safely, you must read and follow the instructions and

Always wear a helmet when riding. Avoid water, wet surfaces, slippery / uneven surfaces, steep hills, traffic, cracks, tracks, gravel, rocks, or any obstacles that could cause a loss of traction and cause a fall. Avoid night riding, areas with poor visibility, and

Warning: Do not ride on side-hills or on an incline of more than 10 degrees. Do not ride at speed which you would not safely control the board. In case of wireless interface or battery error, you may need to rely on skating techniques like foot braking or sliding to



WARNING: AVOID WATER!

Your board is not waterproof, it is water resistant only.

Water damage is not covered under warranty.



WARNING: PINCH POINTS!

Keep fingers, hair, and clothing away from belts, motors, wheels, and all moving parts.



WARNING: RISK OF ELECTRONIC SHOCK!

Do not open or tamper with electronics housing, which also voids the warranty.

PROTECT

- ALWAYS WEAR A HELMET
- Find an open, flat area with clean pavement for your first ride.
- Read the warning on the skateboard and at the beginning of this manual.
- OTHER PROTECTIVE EQUIPMENT IS HIGHLY RECOMMENDED.



STANCE

Follow these tips to ensure a safe riding experience:

- Move the Throttle Wheel in small increments.
- Keep a wide stance on the board.
- Keep a low center of gravity.
- Lean forward when accelerating.
- Lean backward when braking.

FEATURES



Two riding modes:

Sports mode with top Speed 23.5 mph / 38kmh,
Economic mode with top speed 11.8 mph / 19 kmh,
Turbo mode with top speed 26mph / 42kmh.



30% uphill capability:

Actual performance depends on rider' s weight and road condition.



Quick charge:

Board charging time 3.5 hrs (4A Charger)
Remote charging time 30 mins



Light weight construction:

Board net weight 28.2 lbs / 12.8 kg

SPECIFICATION

BOARD

Deck Material: Composite Deck

Deck Dimensions: 1041 mm * 243 mm

Wheel Material: Rubber Tire

Wheel Size: 6.5 inch

Battery Type: Li-ion

Battery Cell Quantity: 36 pcs

Battery Charging Time: 3.5 hours

Motor Type: Brushless Direct Current

Motor Power: 1500 W * 2

Transmission Model: In-wheel motor driving system

Board Weight: 28.2 lbs / 12.8 kg

REMOTE

Material: ABS Plastic

Weight: 60 g

Battery Type: Lithium

Wireless Connection: 2.4 GHz

Charging Voltage: 5 V

Battery Charging Time: 30 minutes

PERFORMANCE

Max. User Weight: 120kg / 265 lbs

Max. Range: 28-35 km / 17-21 mi

Sports Mode Max: 23.5 mph / 38 kmh

Economlc Mode Max: 11.8 mph / 19kmh

Turbo mode Max: 26mph / 42kmh.

CHARGER

Input: AC 100-240V / 50-60HZ / 3.0A Max.

Output: 50.4 V / 2.5 A (4A)

Charge Indicator: Red when charging

Green



BOARD GLOSSARY

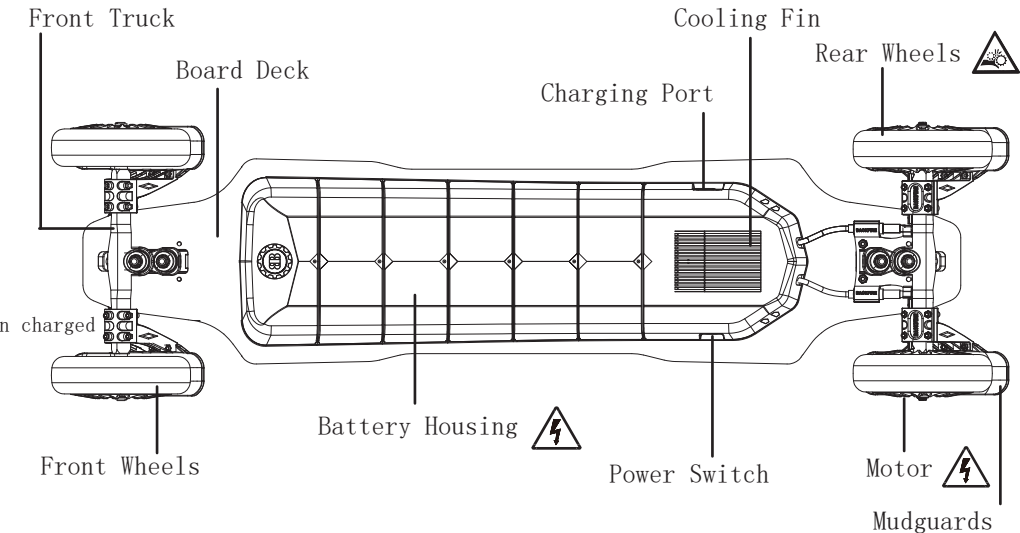

REMOTE GLOSSARY

All-terrain tires with hub motors;

Replaceable rubber tyre with unique honeycomb structure, and don't need to pump up the tires.

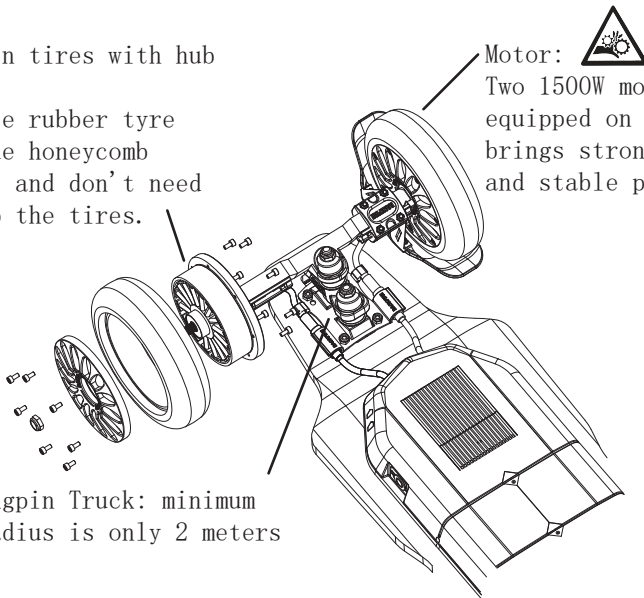

Motor: 
Two 1500W motors are equipped on the board, it brings strong acceleration and stable power output.

Double Kingpin Truck: minimum turning radius is only 2 meters

Note: To replace the tire, please operate under professional guidance.

REMOTE GLOSSARY

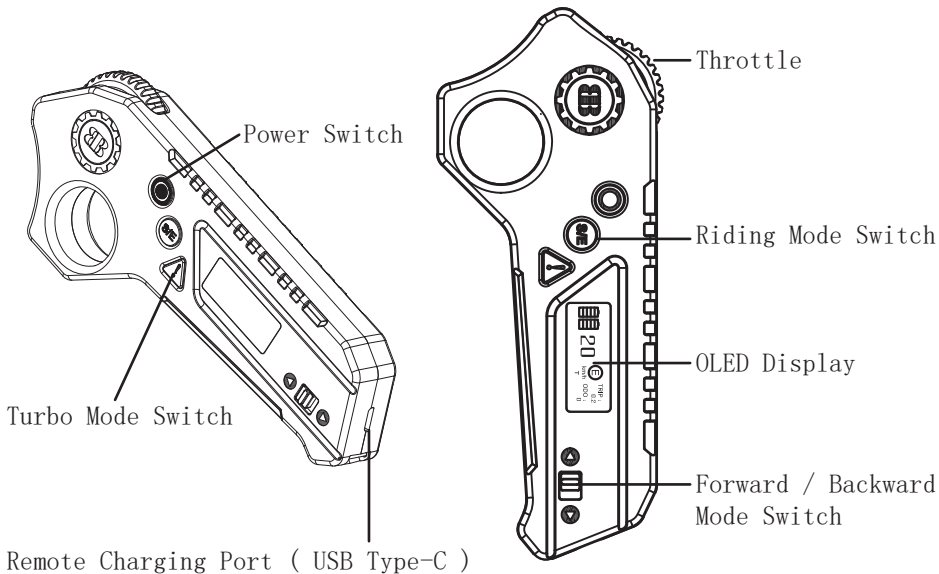

POWER ON/OFF THE REMOTE AND BOARD

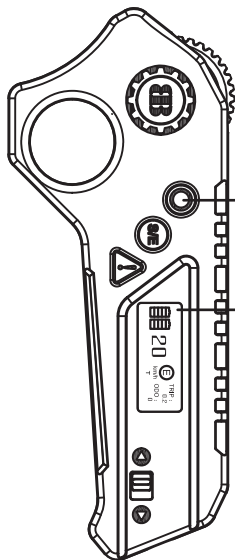

Press power switch for 2 second

Oled display

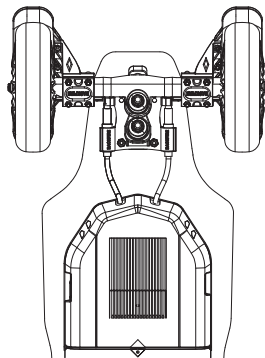

The board is not turned on, or not paired with the remote.

Press the power switch of the board, the board indicator will be turned on, and the remote will show speed, battery, made and other information.

CHECK THE REMOTE / BATTERY LIFE

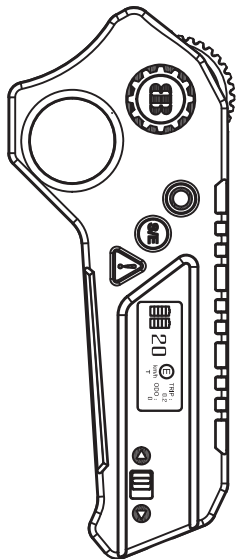

20 Current speed in
ECONOMIC mode /
35 SPORTS mode

Remaining capacity of
the remote battery

Remaining capacity of
the board battery

Economic Mode

Sports Mode

Turbo Mode



Cruise In Economic Mode

Cruises In Sports Mode

TRIP :
1.5 DST TRIP DISTANCE



ODO :
12.5 ODOMETER

Economic mode

Press  , it will enter the economic mode, remote will show 

In economic mode, the top speed is 11.8mph / 19km/h

Sports mode

Press  , it will enter the sports mode, remote will show 

In sports mode, the top speed is 23.5 mph / 38km/h

Cruise mode

During the riding, pressing  to enter the cruise mode, the board will travel at stable speed. Pull the throttle to exit cruise mode.

Turbo mode

Press “” to enter the turbo mode , it will get 20% more power during acceleration, In turbo mode , the top speed is 26 mph / 42mkh.

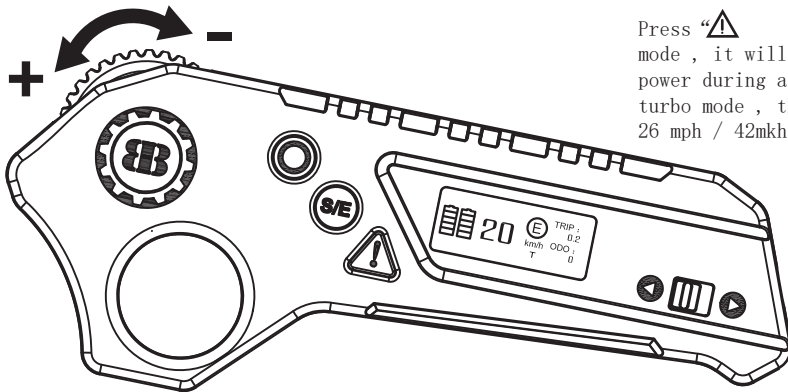

CHARGE THE REMOTE / BOARD

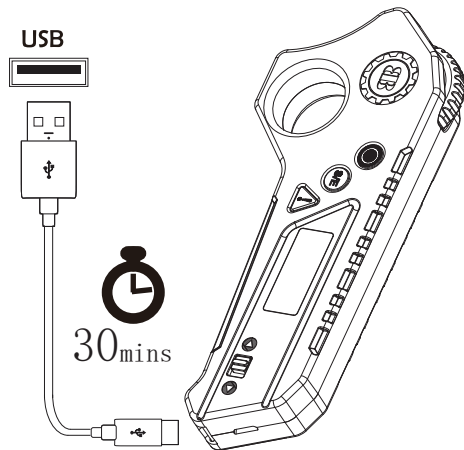
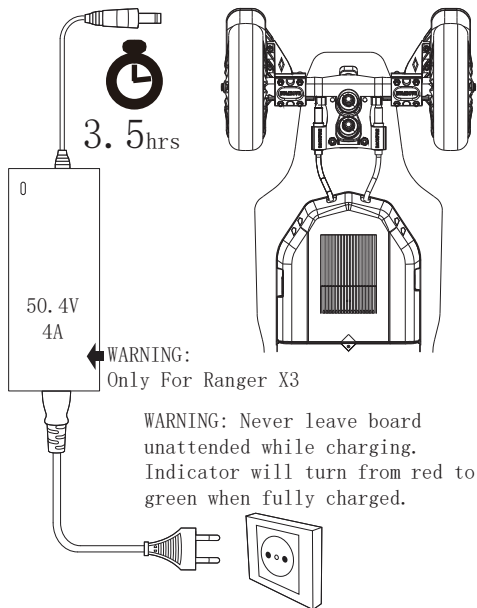

Remote charge time 30 minutes.
Indicator will turn from red to green when fully charged.

RIDING OUTSIDE OF YOUR PRIVATE PROPERTY

Abide by the laws and regulations in your state or country.

Respect other drivers and pedestrians on the road.

Avoid riding in busy traffics and crowded areas.

Do not park your board in a way that blocks people or traffic, or may create a safety issue.

Cross road at designated crosswalks or signaled intersections.

When riding with other riders, keep a safe distance from each other and other transport devices.

Identify and keep a safe distance from hazards and obstacles on the road.

Do not ride your board on private property unless you have obtained permission.

STORAGE AND MAINTAINANCE

Do frequent maintainance checks, make sure all screws are tight before riding.

Clean the bearings regularly.

Turn off board and controller when not in use.

Recharge the battery in well ventilated area.

Do not charge the battery in area with might wet the board or charging units.

Do not leave the board charging unattended.

Stop using the product or charging unit if any wire is damaged.

Only use charging units supplied by us.

Do not use the board battery to power any other equipments.

BATTERY SAFETY

Lithium-ion battery can explode or cause a fire if they are used incorrectly. Therefore, it is recommended to read the following instructions very carefully:

-Each time before riding the board, carefully check the battery pack and especially the protective seal. Make it is undamaged and intact. If in doubt, take the battery to a chemical waste disposal facility.

-Never drop the board.

-Store the board with battery inside in a dry place.

-Never expose the battery to temperature above 100 celsius degrees.

-Only use official board charger for charging board battery.

-Never leave the board unattended when charging.

-Never make the board work when charging.

-If you are not planning to use the board for about 2 months or longer, Charge to 50%-60% and charge it once a month. A lithium-ion battery that has been left empty for too long no longer be charged.

-Charge fully the battery before first time use. This gives it better long-term performance.



WARRANTY

LIMITED WARRANTY:

- We offer 12 months (365 days) warranty on parts from the date when you receive the board.
 - If a defect arises during the Warranty Period, Company will , at is options :
 - 1) Send the new parts to replace the defect parts.
 - 2) Exchange the affected Products with functionally equivalent Products that are new or formed from new and/or previously used parts that are equivalent to new in performance and reliability.
 - This warranty excludes damage resulting from abuse, accident, modifications, unauthorized repairs, neglect, abuse, water damage, or other causes that are not defects in materials and
 - This warranty excludes normal depletion of consumable parts (grip tape, wheels & bearings) unless due to a defect in materials or workmanship.
 - This warranty excludes gifts.
-

FOR ALL RETURN and WARRANTY SHIPPING:

Please keep your shipping box. The warranty does not include damage from shipping in insufficient packaging.

BACKFIRE

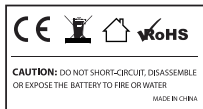

If you want to know about the BACKFIRE ,Please visit the website:
[Http://www.backfireboards.com](http://www.backfireboards.com)