

R2遥控器用户手册

遥控器简介 | 产品以实物为准

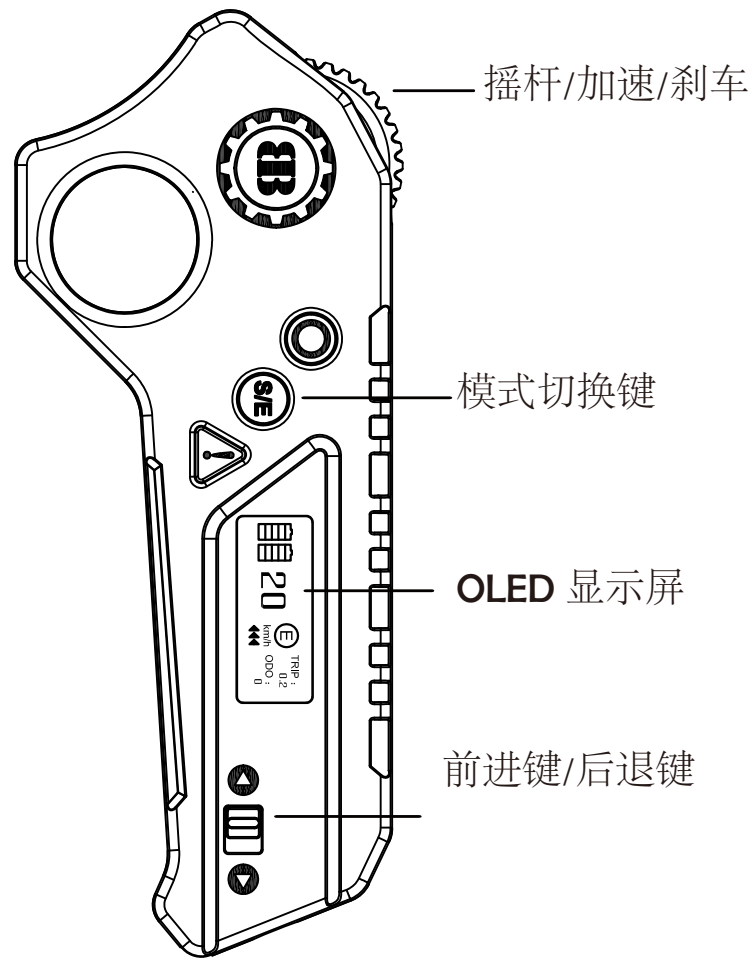

遥控器开机/关机

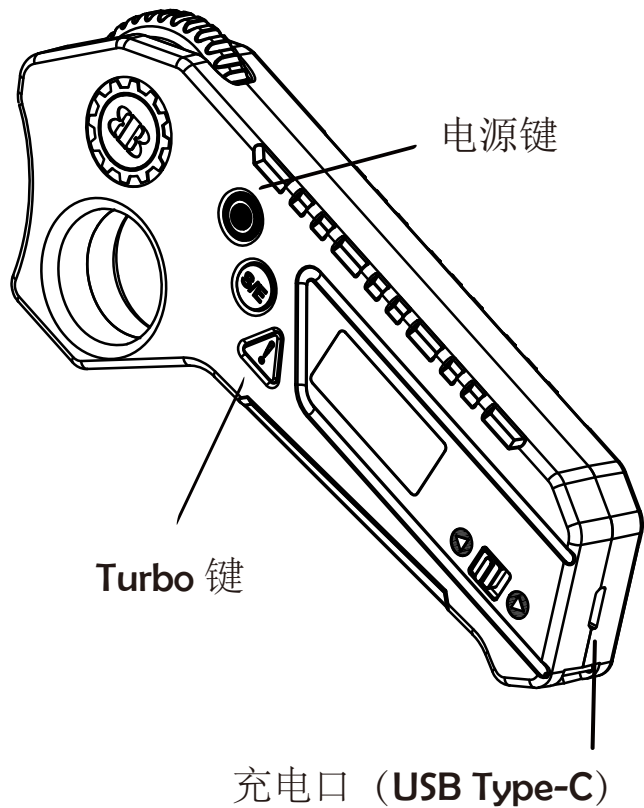
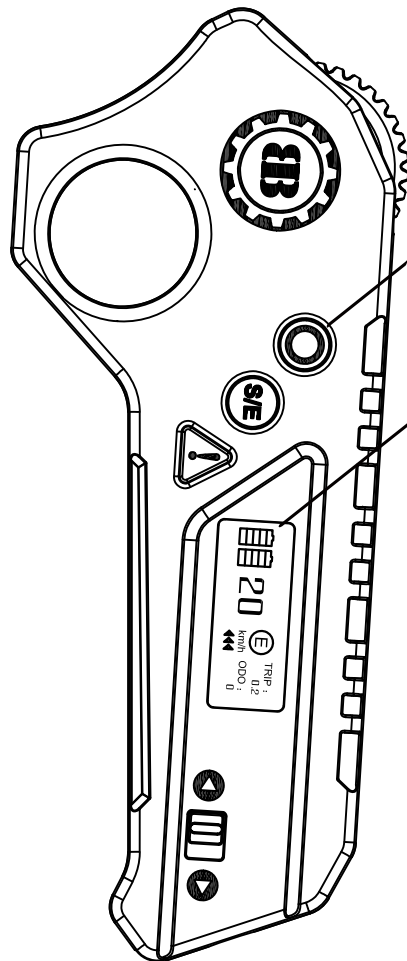

开机：按1s
关机：长按3s

Oled 显示屏

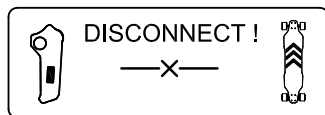

滑板没有开机，或滑板未与遥控器匹配连接。



匹配连接后，按电源键开机，遥控器将显示滑板电量、遥控器电量、当前时速、模式、和里程等信息

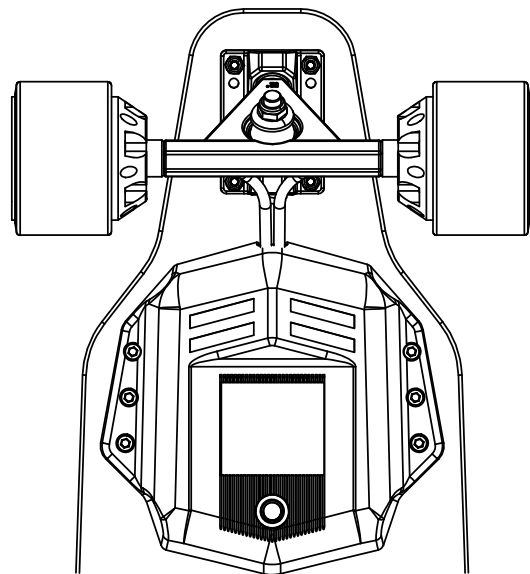

遥控器显示界面介绍

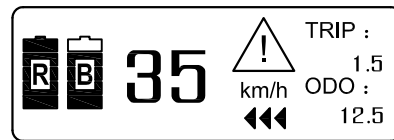
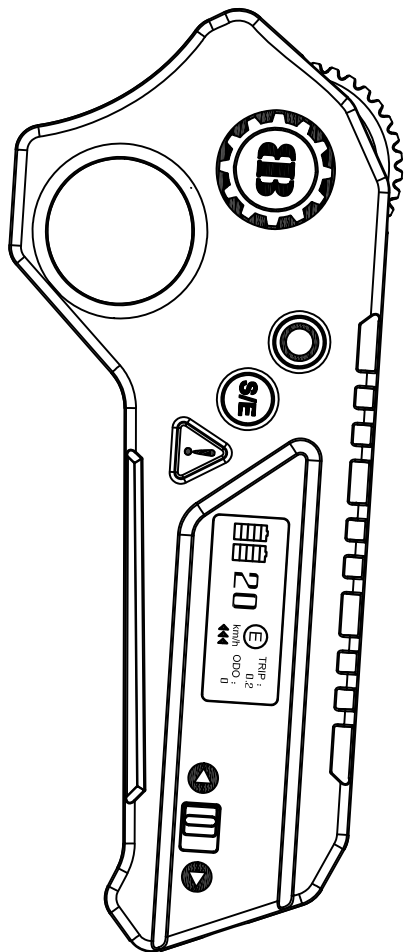

20 经济模式下当前时速

35 运动模式下当前时速



遥控器电池的剩余电量百分比



滑板电池的剩余电量百分比



经济模式



运动模式



Turbo 模式



经济模式下定速巡航



运动模式下定速巡航



前进



后退



TRIP :
1.5

单次滑行里程

ODO :
12.5



里程表

经济模式

按  键，选择经济模式，遥控器显示 

经济模式下，滑板最高时速为20km/h

运动模式

按  键，选择运动模式，遥控器显示 

运动模式下，滑板最高时速为38km/h

注：续航和时速受体重、道路状况等影响，实际可能会有所偏差

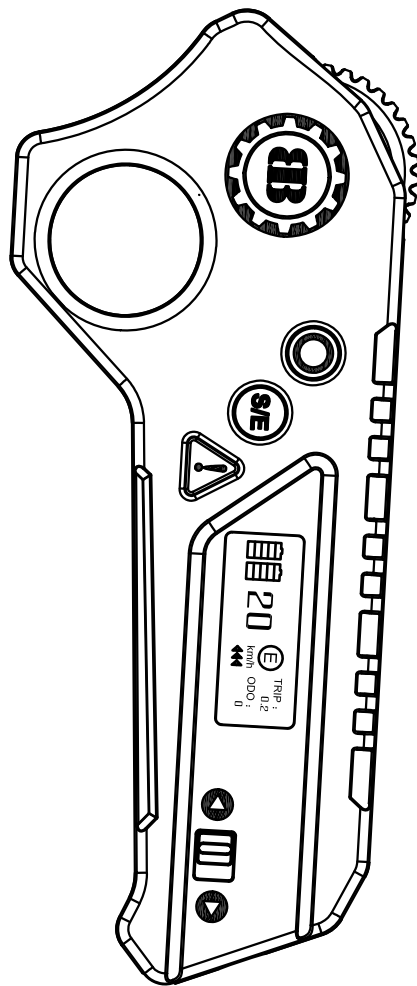

定速巡航

滑行中，按下  键，选择定速巡航模式，滑板以当前时速定速行驶
拉遥控刹车，可以解除定速巡航。

Turbo 模式

按  键，选择Turbo模式，加速度会增加20%。
Turbo模式每次只能使用30秒，之后将进入30秒的冷却时间，才能再次使用

Turbo模式下，最高时速解锁为无限制，请视个人能力慎重选择，安全行驶。

遥控器匹配设置

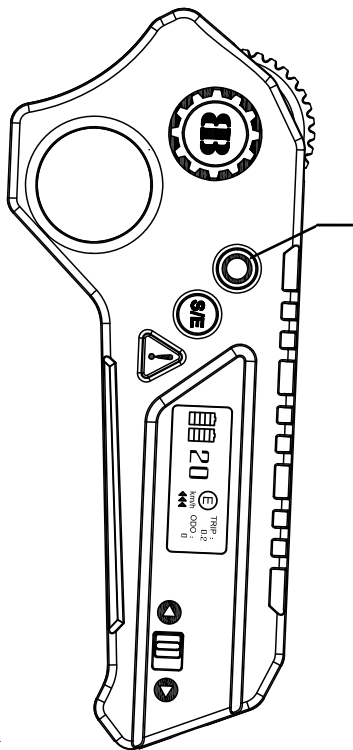

Press power switch for 5 seconds

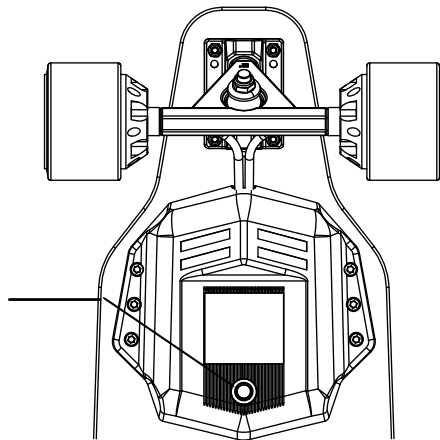

1. 在遥控器和滑板都关机的前提下，同时按住遥控器和滑板的电源键，并保持5秒以上。

2. 当滑板电源键闪烁，且遥控器显示BACKFIRE文字时，松开按键。

3. 按 **S/E** 键，在“km/h”和“phm/mile”间切换，然后按 **⊙** 键选择，出厂默认单位为“km/h”

4. 继续按 **S/E** 键，在“83”、“96”和“165”间切换，然后按 **⊙** 键选择， 出厂默认为“83”（依据轮子的直径设置）

5. 遥控器显示电量、模式、里程、速度等信息，表示匹配成功。

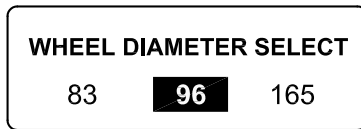

行驶操作说明

前推遥控器摇杆前进/
加速

初学者建议选择经济模式，小幅推动摇杆，缓慢加速。滑板行驶时请采取稍宽的站姿，并降低重心。滑板加速时请稍向前倾。

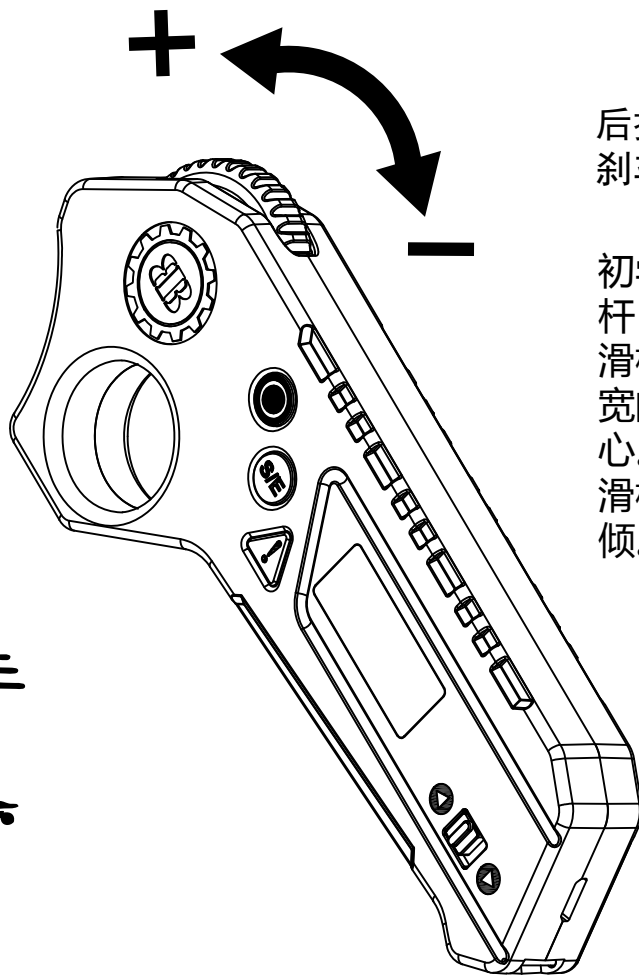
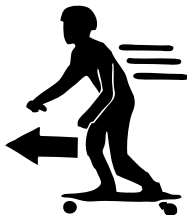

后拉遥控器摇杆减速/
刹车

初学者请小幅推动摇杆，缓慢加速。滑板行驶时请采取稍宽的站姿，并降低重心。滑板刹车时请稍向后倾。

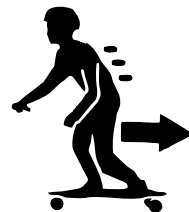

充电操作说明

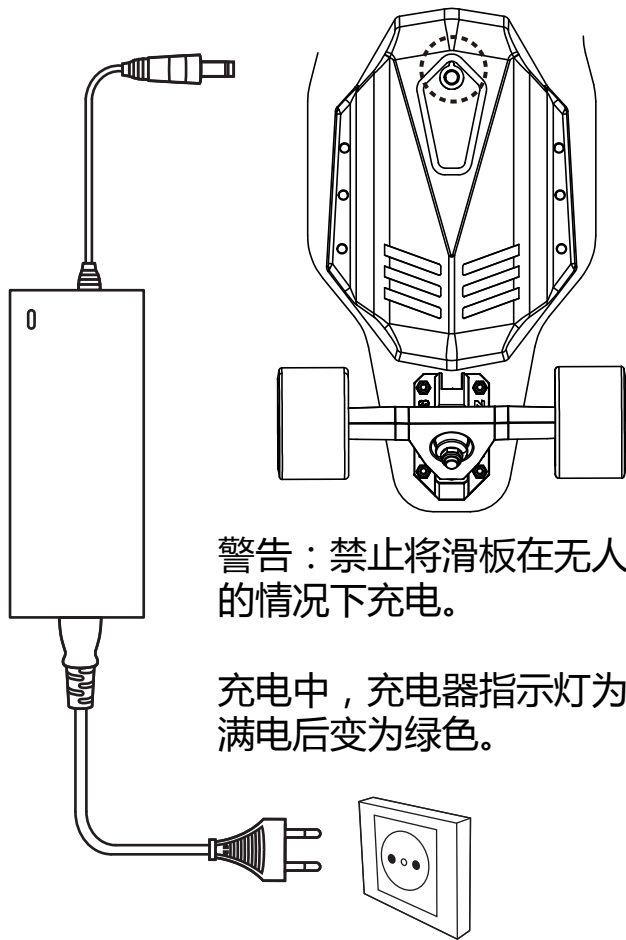

警告：禁止将滑板在无人看管的情况下充电。

充电中，充电器指示灯为红色，
满电后变为绿色。

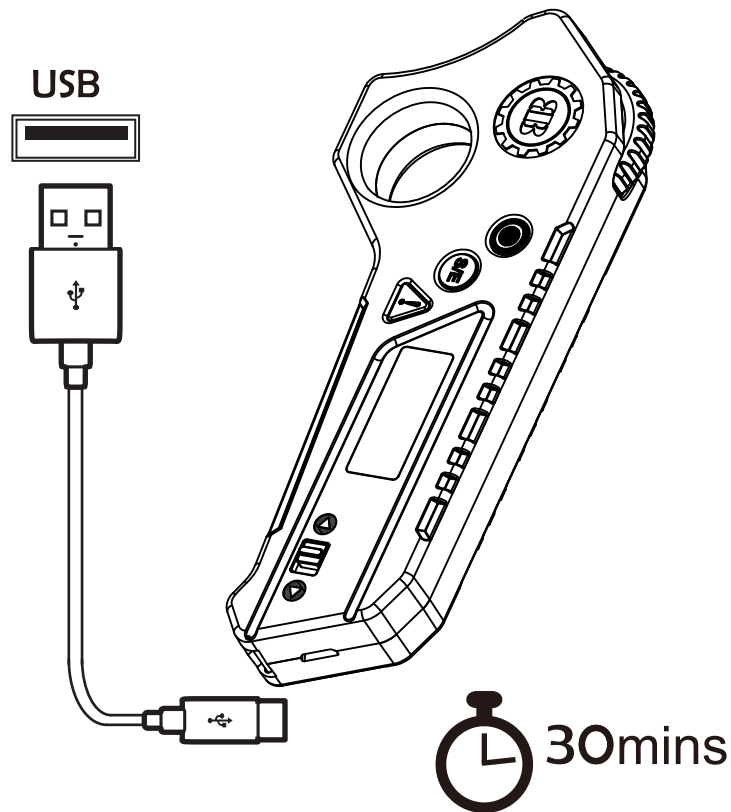

遥控器充电时间30分钟。
充电中，遥控器显示当前流水电量，
充电完成显示满格。

BACKFIRE

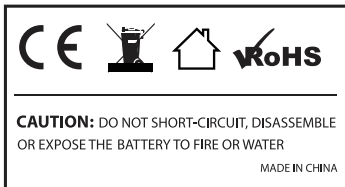

想了解更多关于BACKFIRE信息，请登录官方网站：
[Http://www.backfireboards.com](http://www.backfireboards.com)