

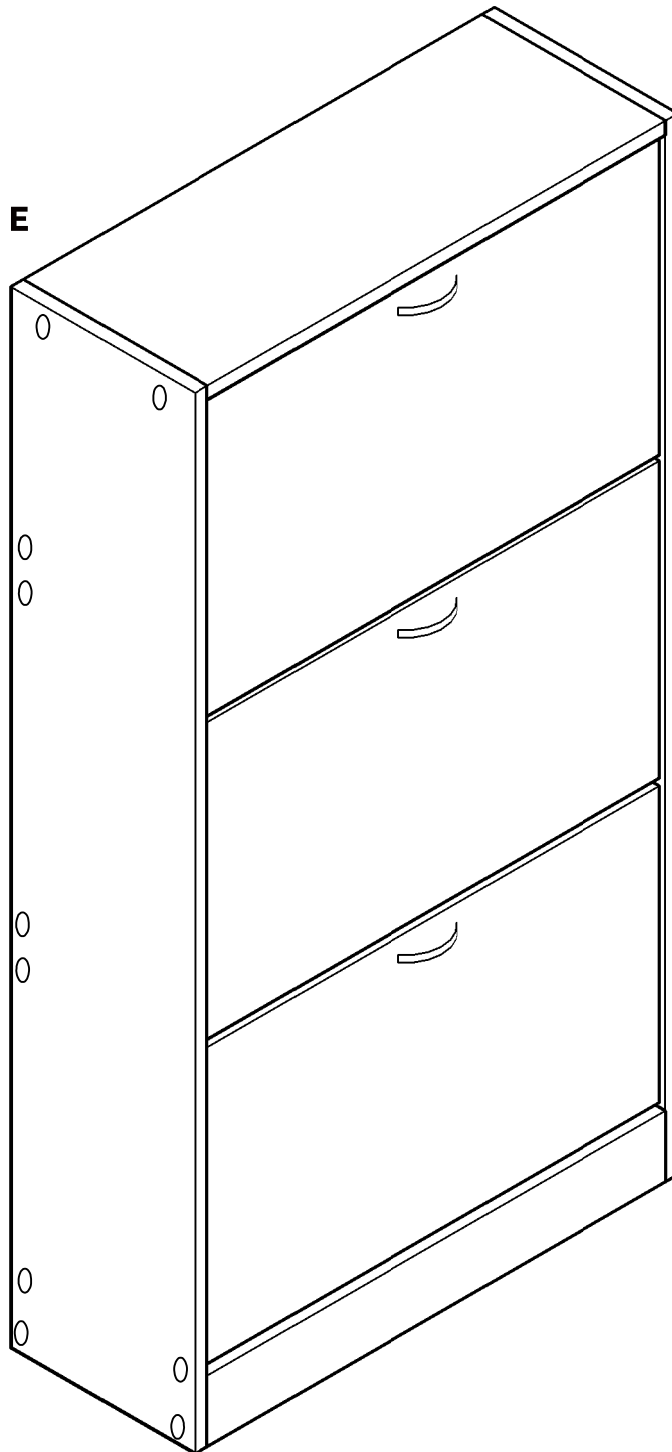







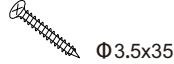
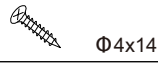

CHERRY TREE

FURNITURE

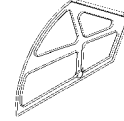
www.daalshome.co.uk



NO.	QTY.	LINEDRAWING	DESCRIPTION
A	20	 Ø3.5x35	SCREW
B	36	 Ø4x14	SCREW
C	3		HANDLE
D	6		HANDLE SCREW
E	4		LEG NAIL
F	20		ROUND COVER
G	6		BRACKET
H	6		AXLE BASE
I	6		AXLE
J	6		STOPPER
K	6		SCREW

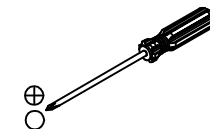
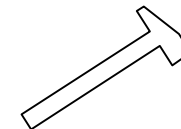

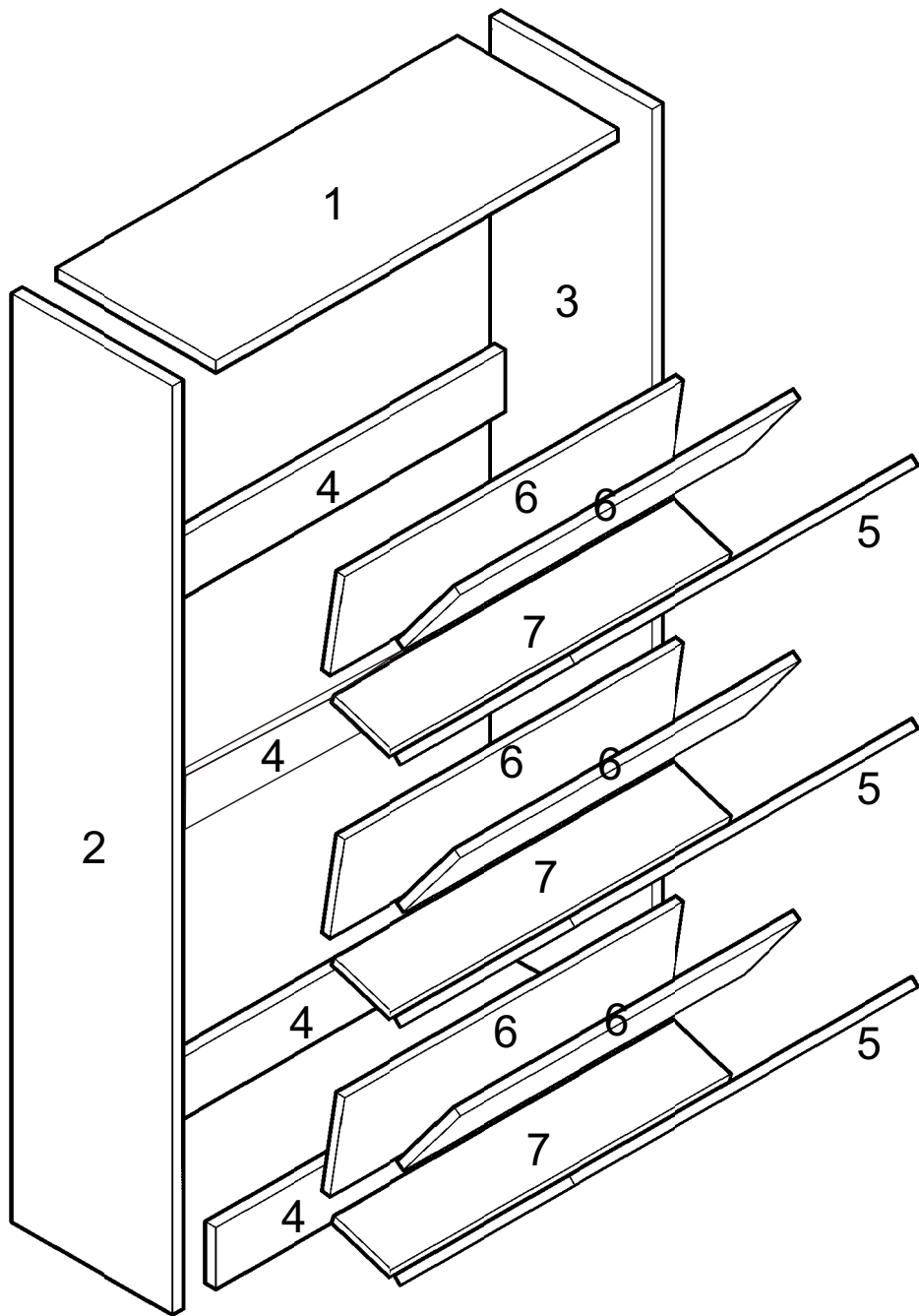

NO.	QTY.	LINEDRAWING	DESCRIPTION
1	1		TOP BOARD
2	1		LEFT BOARD
3	1		RIGHT BOARD
4	4		BACK RAIL
5	3		DOOR
6	6		SHELF
7	3		BOTTOM SHELF

1

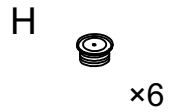
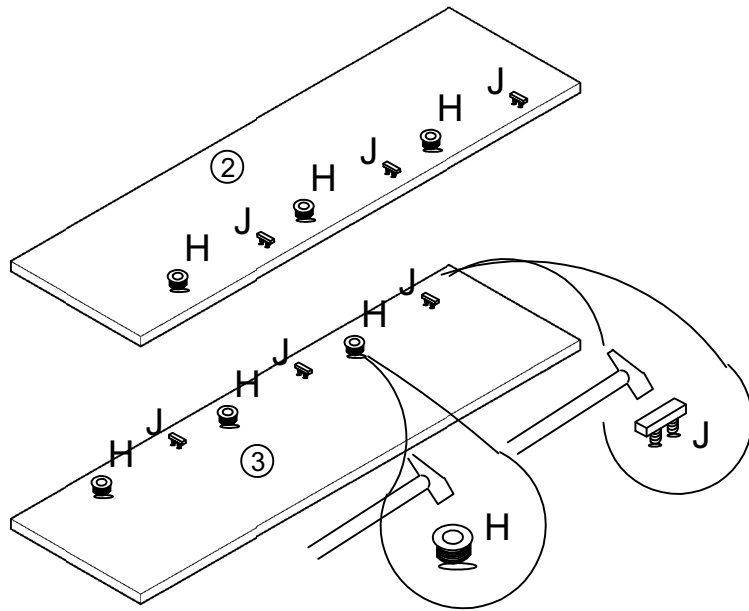

PLEASE ENSURE THAT HARDWARE IS TIGHT TO THE PANEL FIRMLY FOR OPTIMUM STRUCTURE.

3

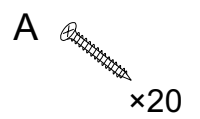
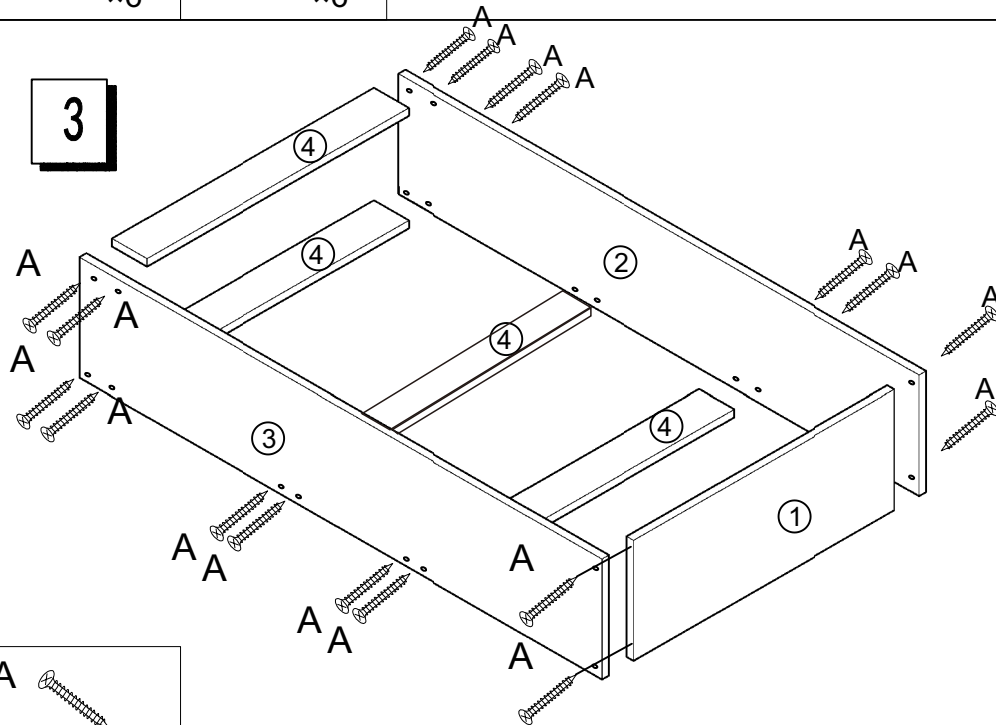

2

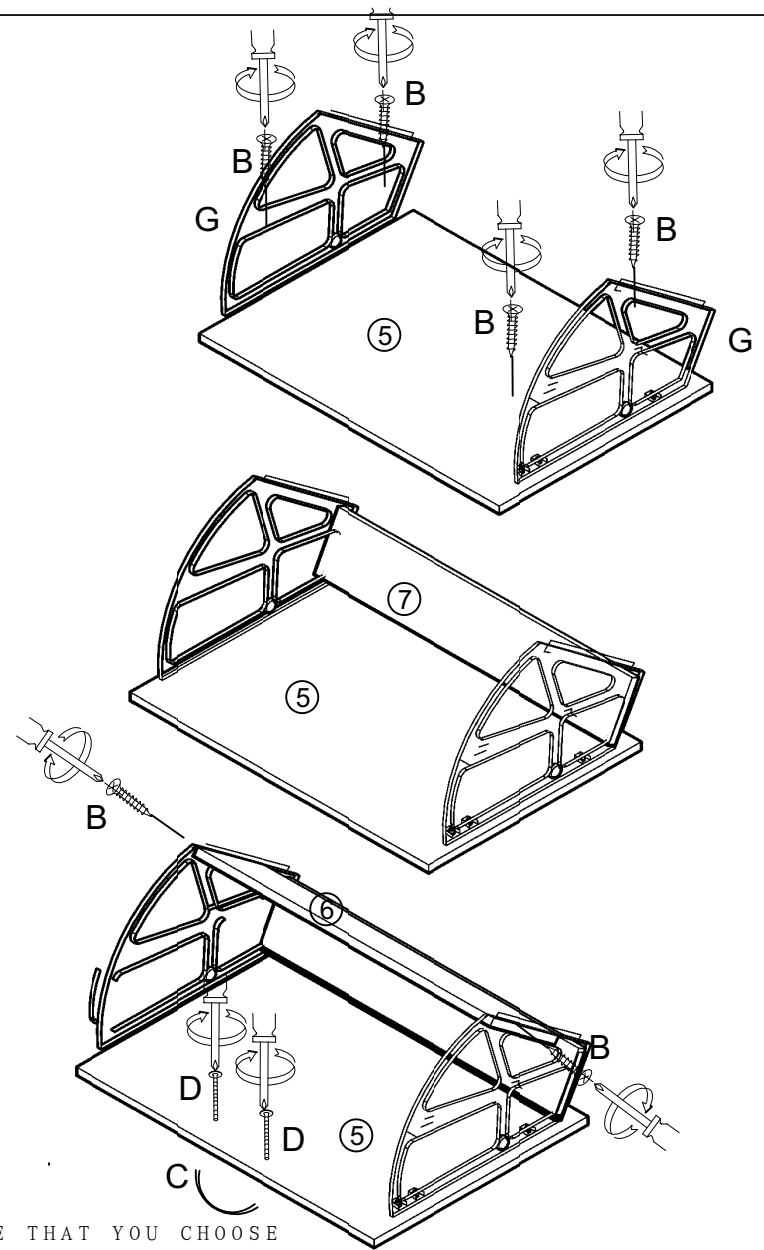

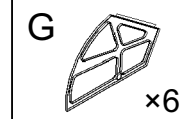
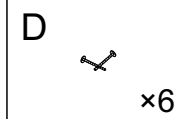
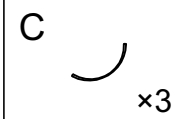
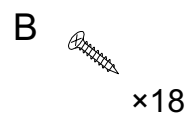

PLEASE ENSURE THAT YOU CHOOSE THE CORRECT HOLE POSITIONS.
 WARNING: AVOID USING ELECTRIC POWER TOOLS, PLASTIC BRACKET MAY BREAK.
 PLEASE REPEAT STEPS AS NECESSARY.

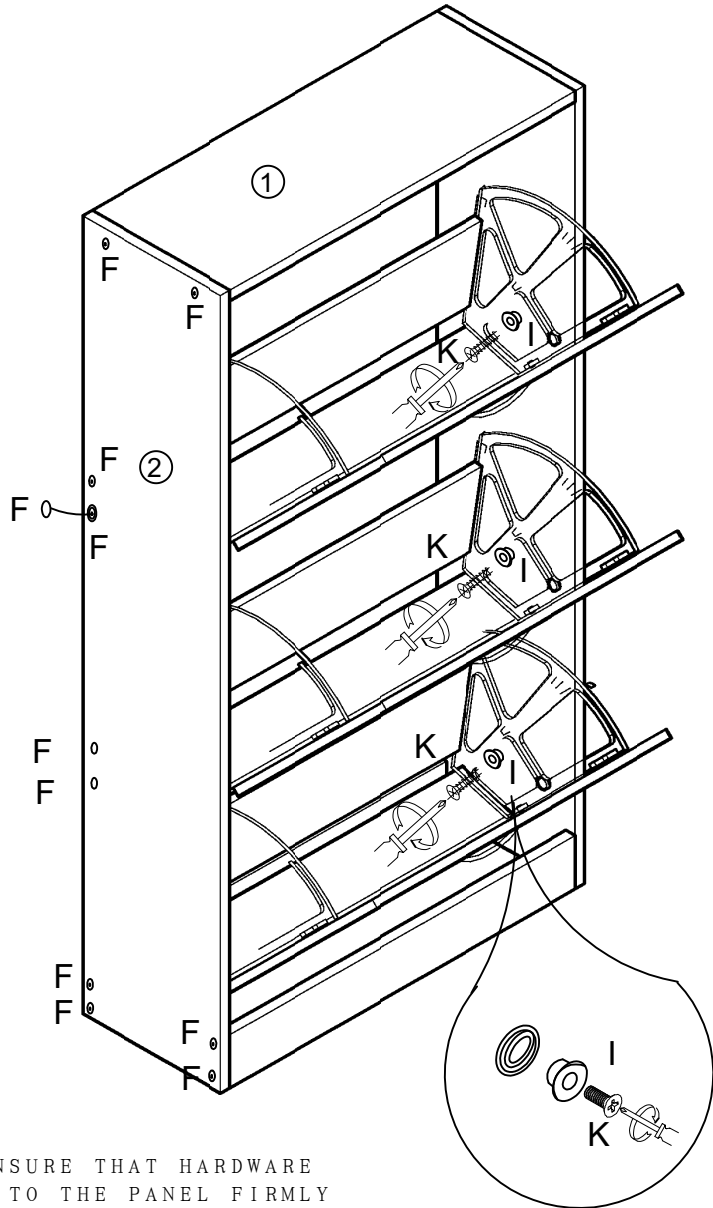

4





PLEASE ENSURE THAT HARDWARE IS TIGHT TO THE PANEL FIRMLY FOR OPTIMUM STRUCTURE.
 WARNING: AVOID USING ELECTRIC POWER TOOLS, PLASTIC BRACKET MAY BREAK.

I	K	F
		
x6	x6	x20

5

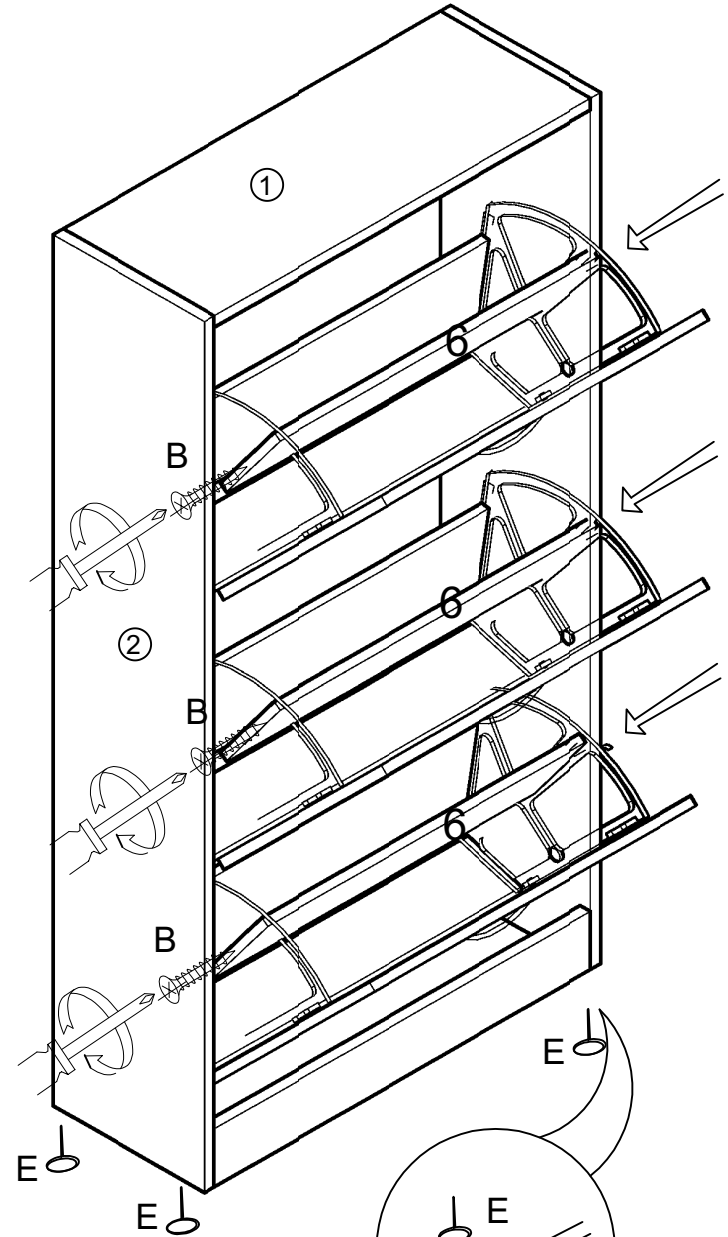
CONNECT BRACKET "G" TO SHELF "6" USING SCREW "B"



B	E
	
x6	x4

