

C189

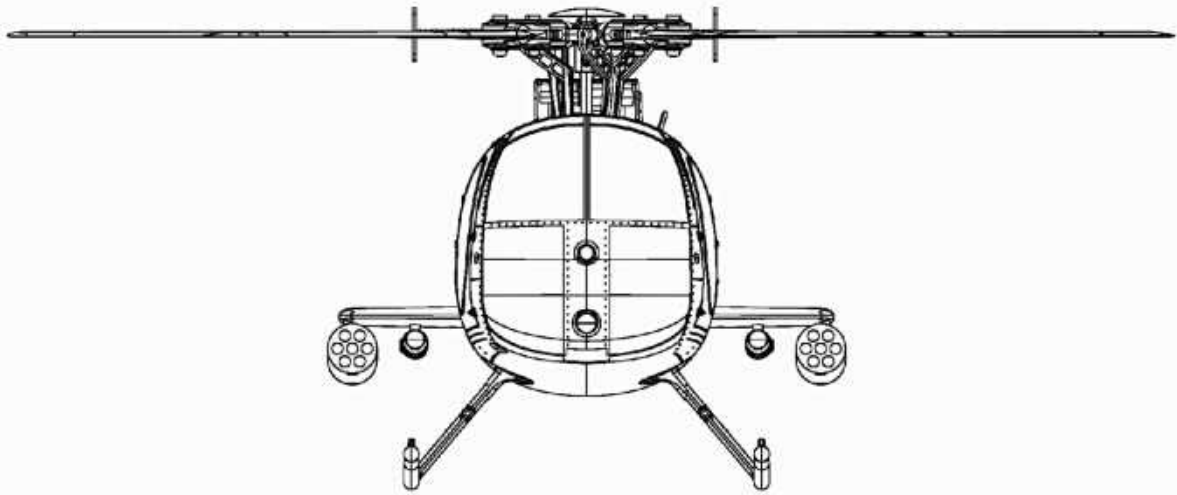

BETRIEB SANLEITUNG/
USER MANUAL

RC REA[®]

Important Note

C189

■ Please read the manual to learn the function of the this product before operation. Damage to the product and potential personal injury may occur if you make an operational error.

This is a RC helicopter, not a toy. You should not only have a prudent operation, but also to have an operational basis. All children using it should be under adult supervision. The manual includes safety, operation and maintenance. In order to avoid causing damage or serious injury, please obey the instructions and warnings before you using this product.

Additional Safety Precautions And Warnings

C189

- 1.Recommended age of users: Not suitable for children under 14 years old.
- 2.Operate it in an open space, away from the traffic and people.
- 3.Obey the instructions and warnings, includes the use of optional equipment.
- 4.It has to stay away from chemicals. Small parts and electric equipment must be out of the reach of children.
- 5.Keep away from water because this product has no waterproof function.
- 6.Do not put any parts in the mouth, it will cause injury or death.
- 7.Don't operate the model if the transmitter's battery is in low voltage.
- 8.Don't view the beam of the light emitting diodes, it would effect the eyesight.
- 9.The motor and electric equipment will be heat after flight. Please do not touch them to avoid scald.
- 10.In order to avoid causing damage, please do not touch the high-speed.



Note: Using the original factory USB charger can ensure charging safety. Suggest you use the original factory USB charger part, other chargers may cause battery damage and property damage.

Warnings! The battery will fire, explode or leak if not strictly observing this item described below. :

1. Do not immerse the battery in water or seawater, and keep the battery in a cool dry environment during stands by period.
2. Keep all batteries out of the reach of little children. Consult a doctor immediately if a battery is swallowed.
3. Do not use or leave the battery near a heat source such as fire or heater.
4. Use the battery charger specifically for that purpose when recharging.
5. Do not reverse the positive (+) and negative (-) terminals.
6. Do not connect the battery to an electrical outlet.
7. Do not dispose the battery in fire or heat.
8. Do not short-circuit the battery by directly connecting the positive (+) and negative (-) terminals with metal objects such as wire.
9. Do not transport or store the battery together with metal objects such as necklaces, hairpins etc.
10. Do not strike or throw the battery against hard surface.
11. Do not directly solder the battery.
12. Do not unpack the battery with a nail or other sharp object.
13. Never disassembling the battery in any way.

Note: The battery can not be placed for a long time under full power and low power.

Otherwise, the battery will not be charged or the battery will be wrapped. For long-term storage, please charge the battery to 7.8V and store it in a dry and safe place.

Helicopter Parameters

C189

Length:	335 mm
Height:	126 mm
Weight:	228G
Propeller length:	320 mm
Battery Specification:	1200mAh
Flight Time:	About 15-17 min.
Main Motor:	1807
Tail Motor:	1103
Charge Time:	About 90 min.

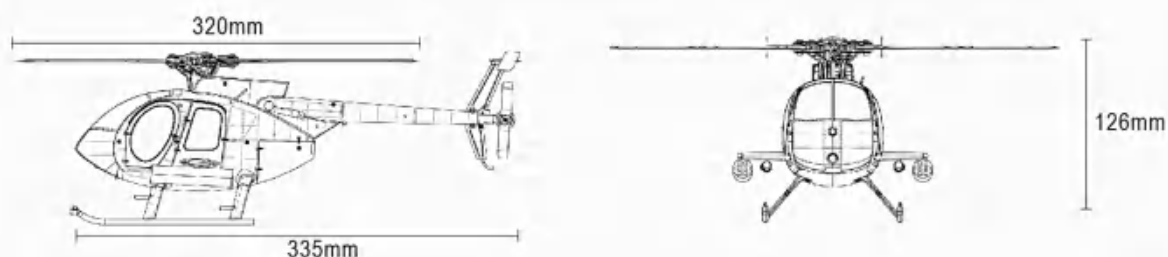

Packaging List

C189

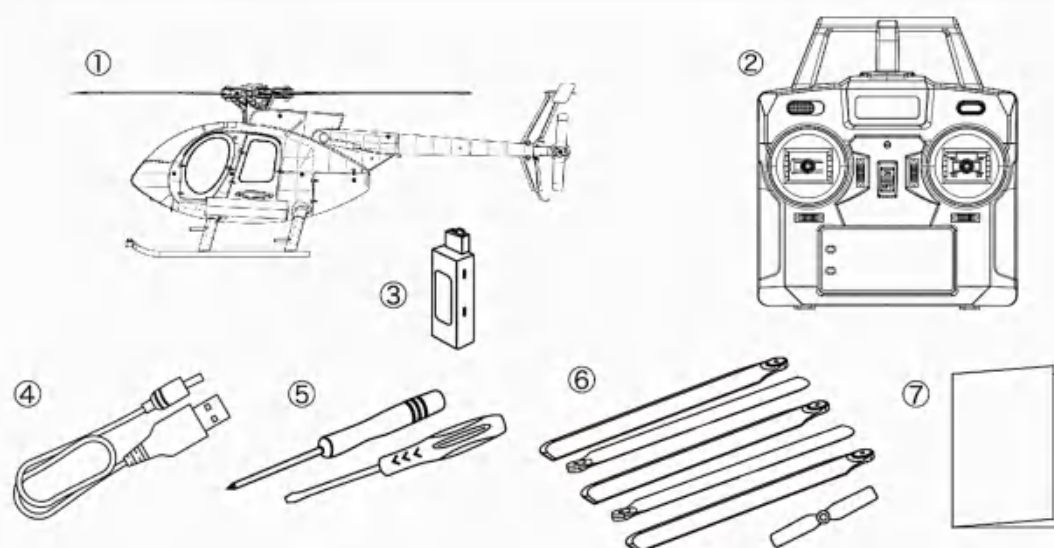

- ① Helicopter ② Remote Control ③ Lipo battery ④ USB charger
⑤ Phillips screwdriver+hex Screwdriver ⑥ Upper connecting rod / Propeller / tail rotor ⑦ Instruction manual

Introduction of transmitter function

C189

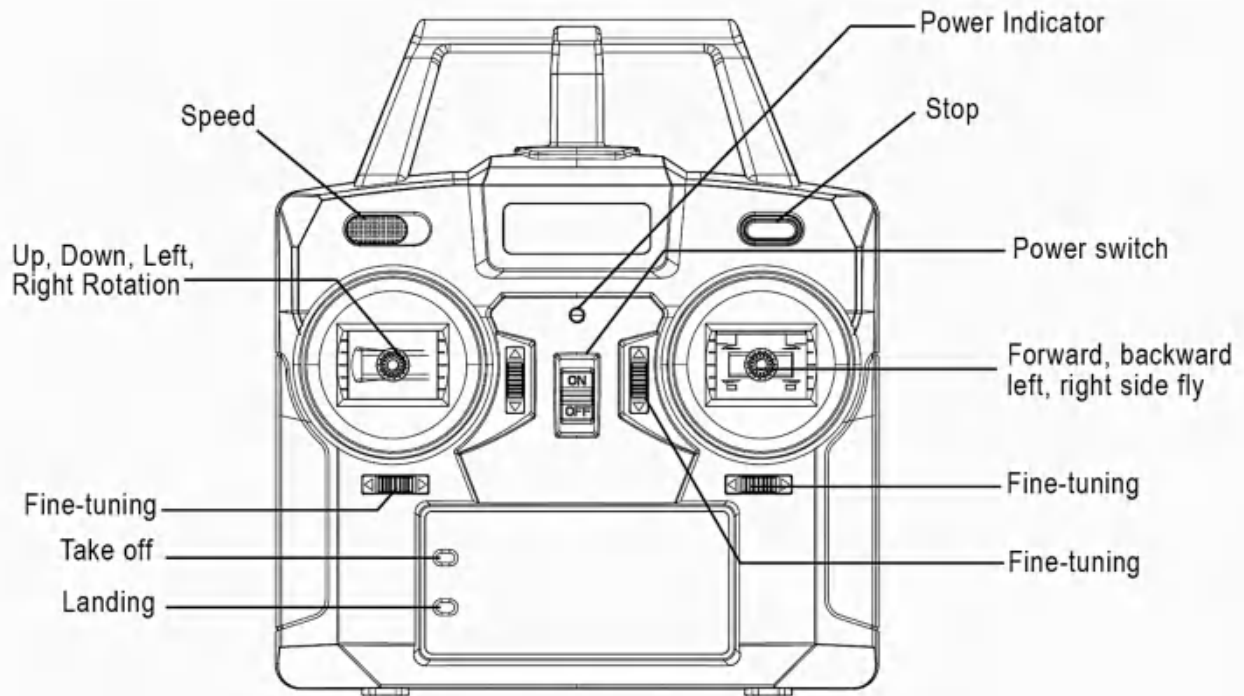

PARTS

C189

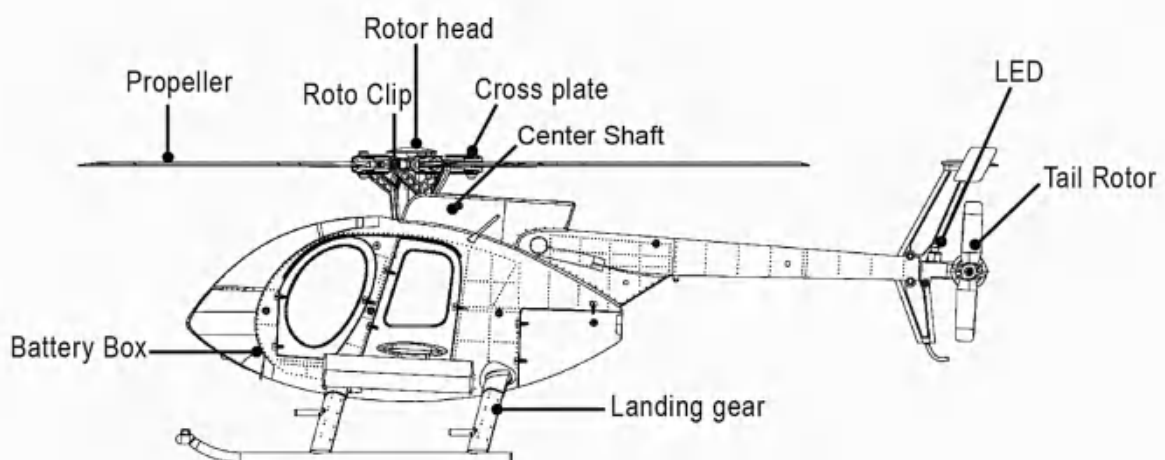

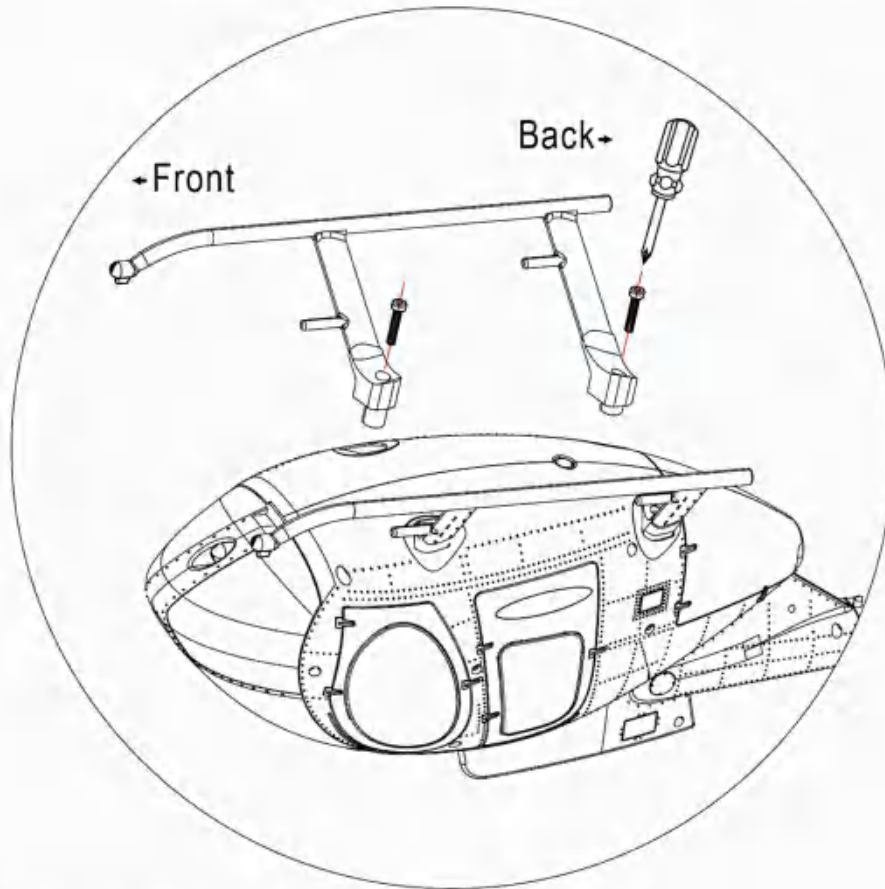

Remove the landing gear and compare it with the diagram.
 Align the landing gear with the corresponding holes on the aircraft body.
 Pay attention to the front and rear orientation.
 Install the left and right landing gear one by one. Tighten the screws to secure.

Antenna Installation Method

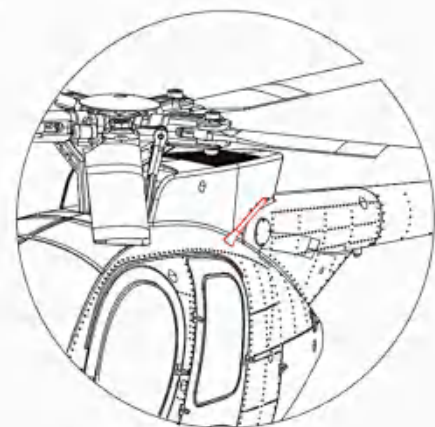
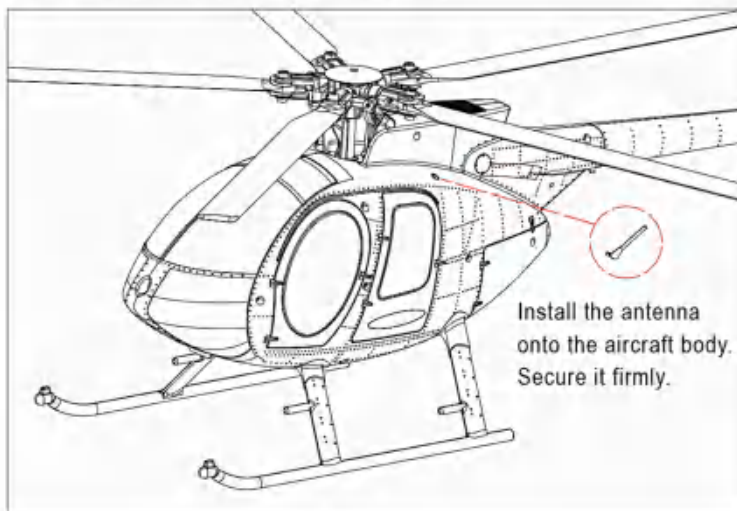

As shown in the diagram

Weapon Mounting Steps: Please install in numerical order.
Install accessory (1.2).
Attach the installed accessory to the cover plate (refer to Figure 3.4).
Secure the upper cover plate to the aircraft body (refer to Figure 5).
Fasten the lower and upper cover plates together (refer to Figure 6).

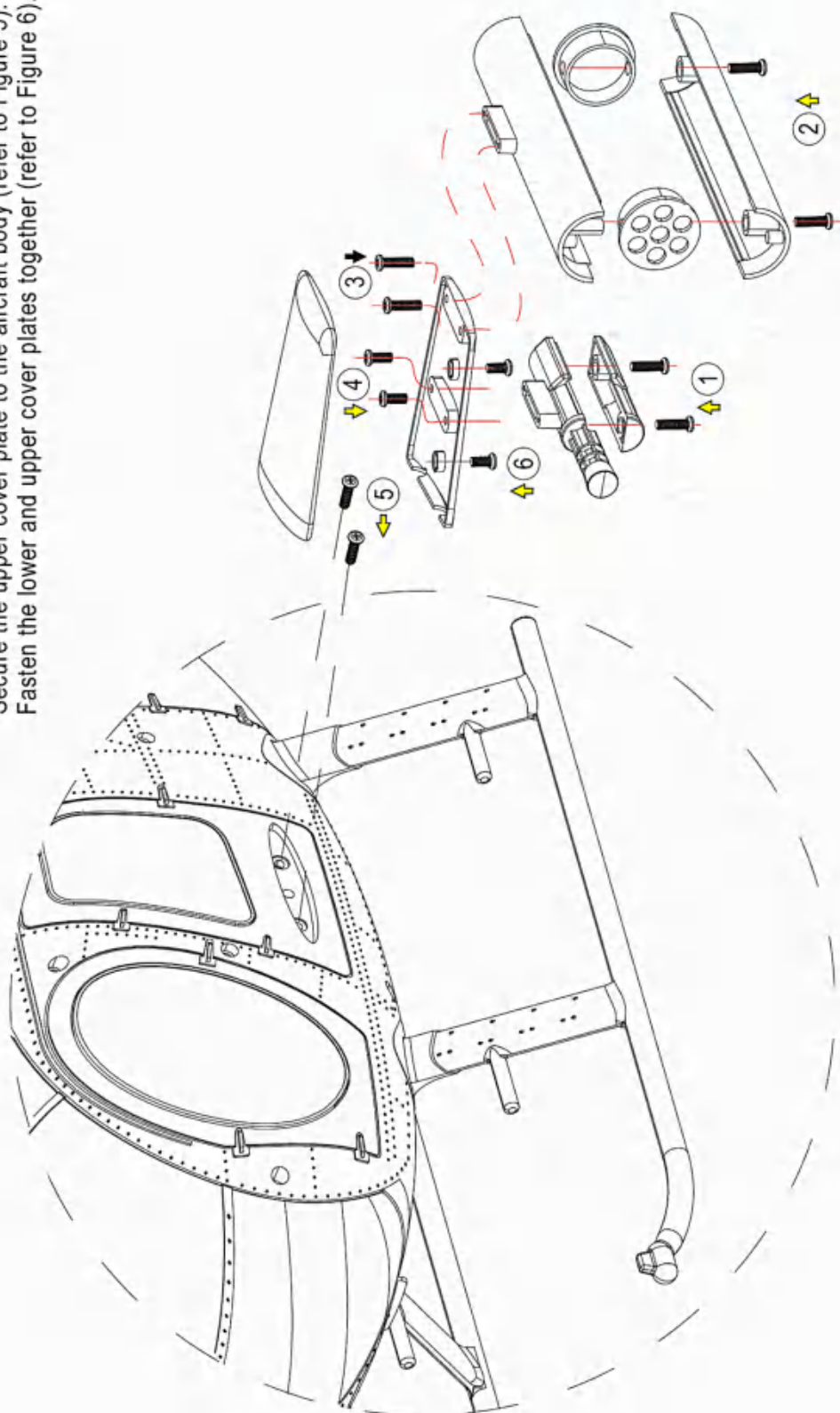

Batteries Charging Method

C189

Charging Method 1:

Charging Battery by the USB port on a computer.

Description:

1. Connect the USB charger with USB port.
2. Connect the battery with USB charger: LED on when charging, LED OFF when charging finished

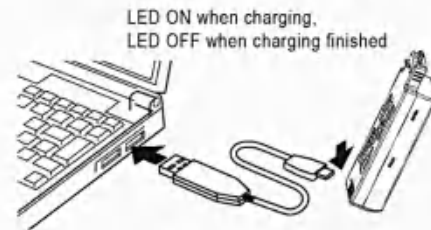

Charging Method 2:

Charging Battery by power supply adapter.

Description:

1. Connect the USB charger with power supply adapter.
2. Connect the battery with USB charger: LED on when charging, LED OFF when charging finished

Charging Method 3:

Charging Battery by power bank.

Description:

1. Connect the USB charger with power bank .
2. Connect the battery with USB charger: LED on when charging, LED OFF when charging finished

Installation method of remote controller battery

C189

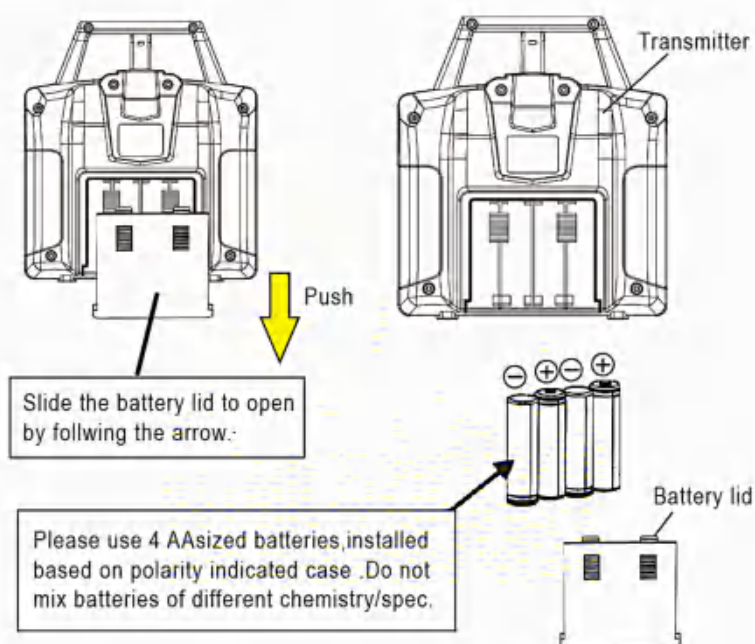

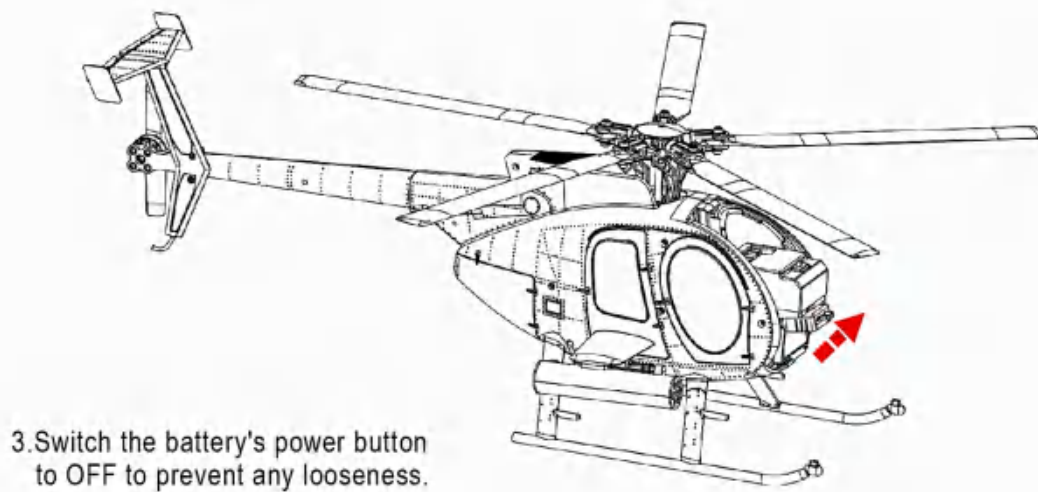
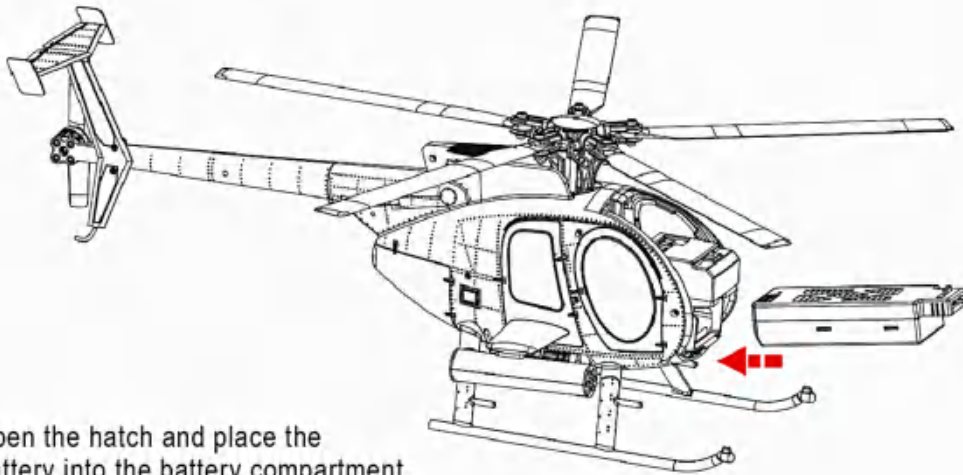

First Flight Preparation CAUTION

C189

1. ensure sufficient power supply of the transmitter and helicopter.
2. Keep a flight in a suitable space which away from the traffic, people, electricity pylons and pool.
3. Do not lock the main rotor screws too tightly to keep folding smoothly. If the main rotor screws are too tight, the helicopter will shake when flying.
4. Under emergency situation, you can press "sharp stop" button for 3" to land the helicopter without rotating.
(Note: this action may cause helicopter crash.)

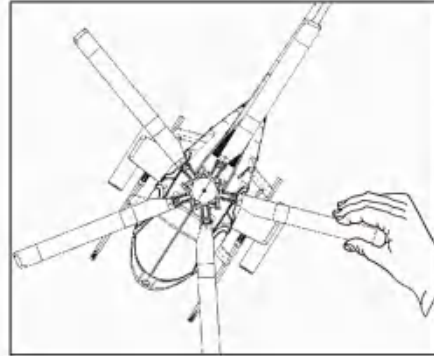

Direction of operation

C189

If you are unfamiliar with the control of the C189, take time to familiarize it before your first flight.

Throttle

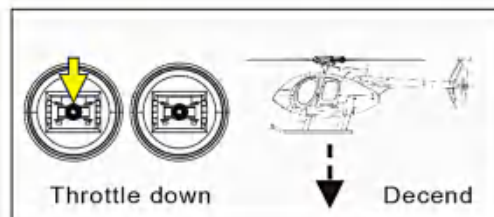
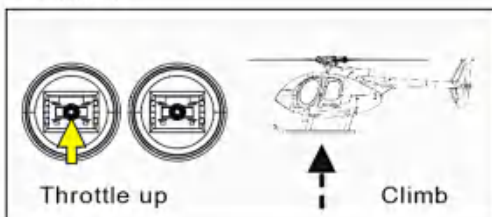

Rudder left

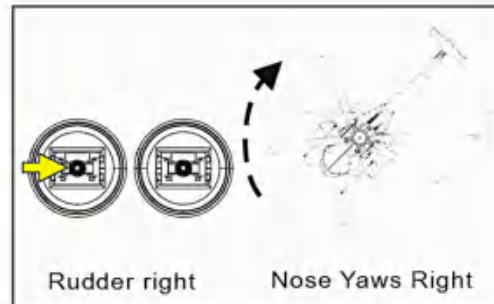
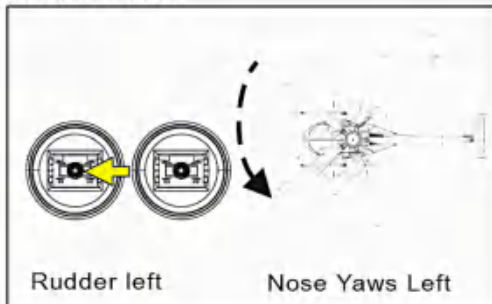

Elevator

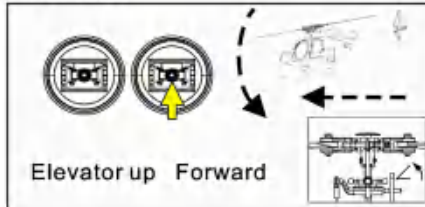

Elevator up Forward

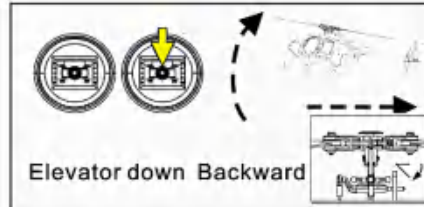

Elevator down Backward

Aileron

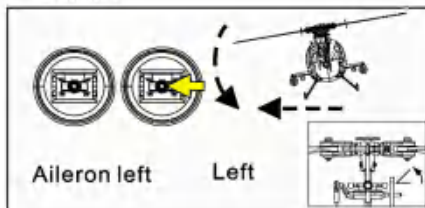

Aileron left Left

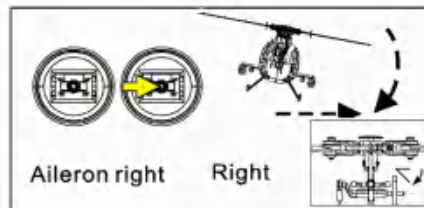

Aileron right Right

Flight Operation Steps

C189

1. Turn on the transmitter and let helicopter stay near to transmitter.
2. Install the aircraft battery in the battery compartment safely and securely turn on the aircraft power.
3. The lights of the helicopter and the remote control flash at the same time. Then push the throttle stick from top to bottom quickly. The remote control makes a 'DI' sound, and the indicator lights of the helicopter and remote control are always on, which means binding successful.
4. Pull the two joysticks to outer eight angles to start the helicopter. (You can also press the one-key takeoff button to take off the helicopter directly.)
5. Keep the helicopter head forward, and keep safe distance with the helicopter.
6. When manually operating the aircraft to land, please keep the throttle stick at the bottom for 2-3 seconds, and then release it after the propeller has completely stopped rotating. (This operation is not required when using the one-key landing function)

- △Note:** 1. In order to avoid hitting, do not look at the helicopter at hip level when it fly.
2. In order to avoid distractions, please confirm without other transmitters at work around.

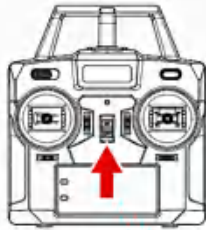

1. Corresponding to step 1C

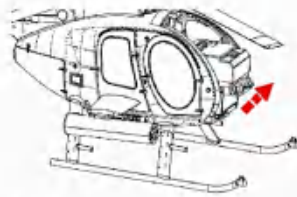

2. Turn on the battery power switch

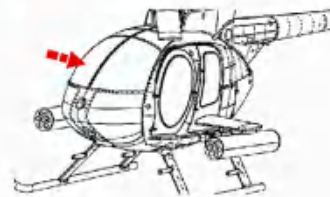

3. Close the hatch.



4. Place the aircraft horizontally.

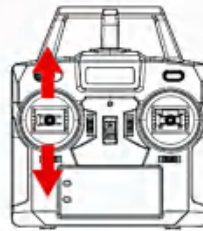

5. Corresponding to step 3C

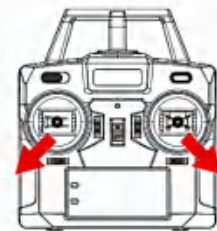

6. Corresponding to step 4



Forward flight

Keep a safe distance of more than 2 meters

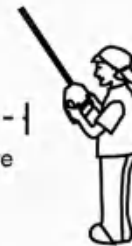

Note: Beginner should pay attention to the direction of flight. Keep the head forward to avoid causing injury .



Flight Yaw correction method

C189

Press the trimming button when helicopter has yaw problems.

The helicopter has set up hovering. If you are dissatisfied with hovering or the helicopter have a yaw, please follow these steps to adjust.

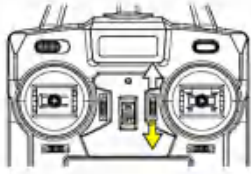
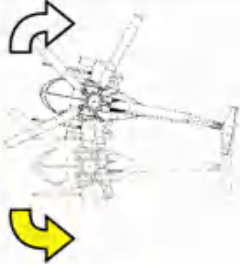
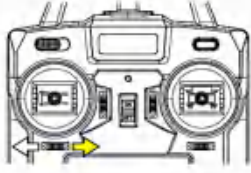
Take off with the throttle joystick. According the direction of yaw, press the fine-tuning button in the opposite direction until the plane hovering.

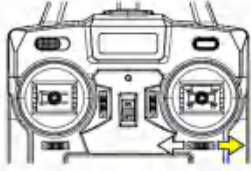
Forward/ backward Yaw			Fine-tune according to the direction of the arrow
Left/right Yaw			Fine-tune according to the direction of the arrow
Side fly Yaw			Fine-tune according to the direction of the arrow

Receiver diagram

C189

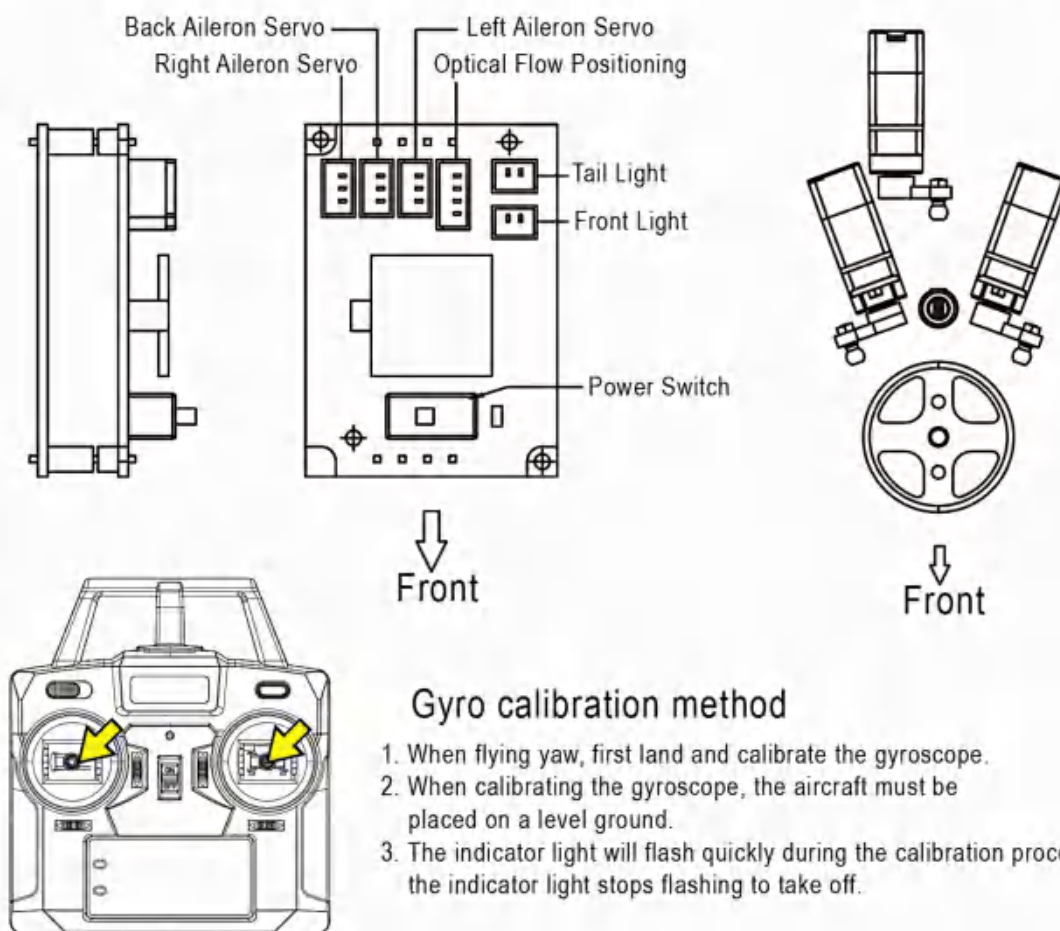

Commonly used parts replacement instructions C189

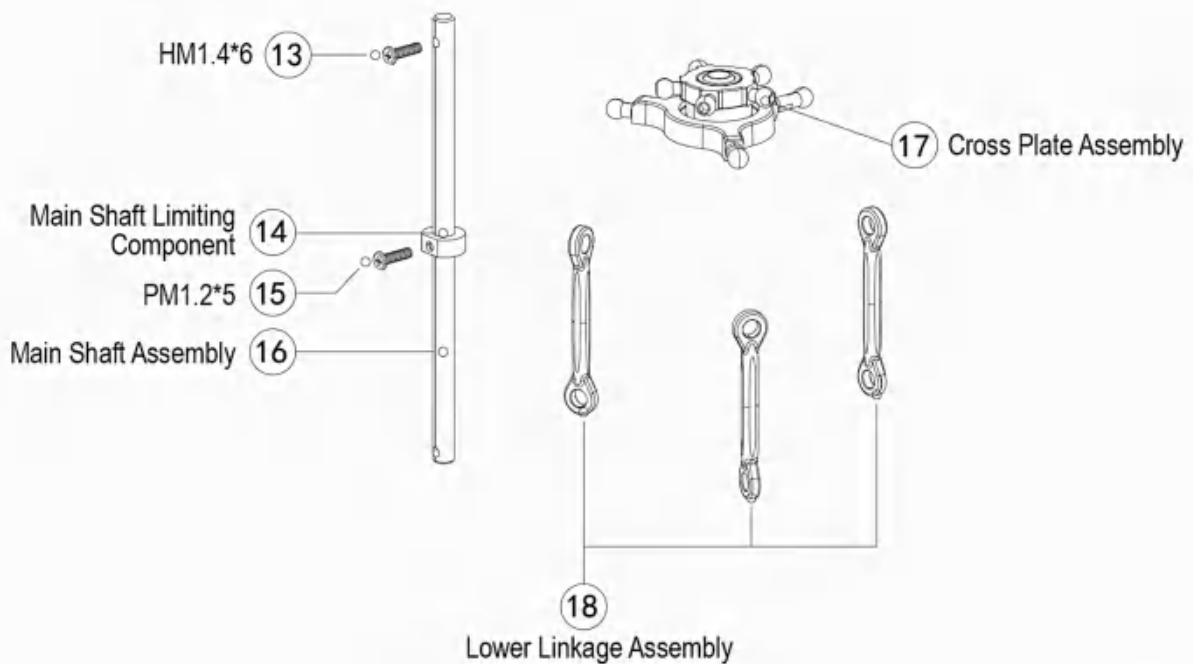
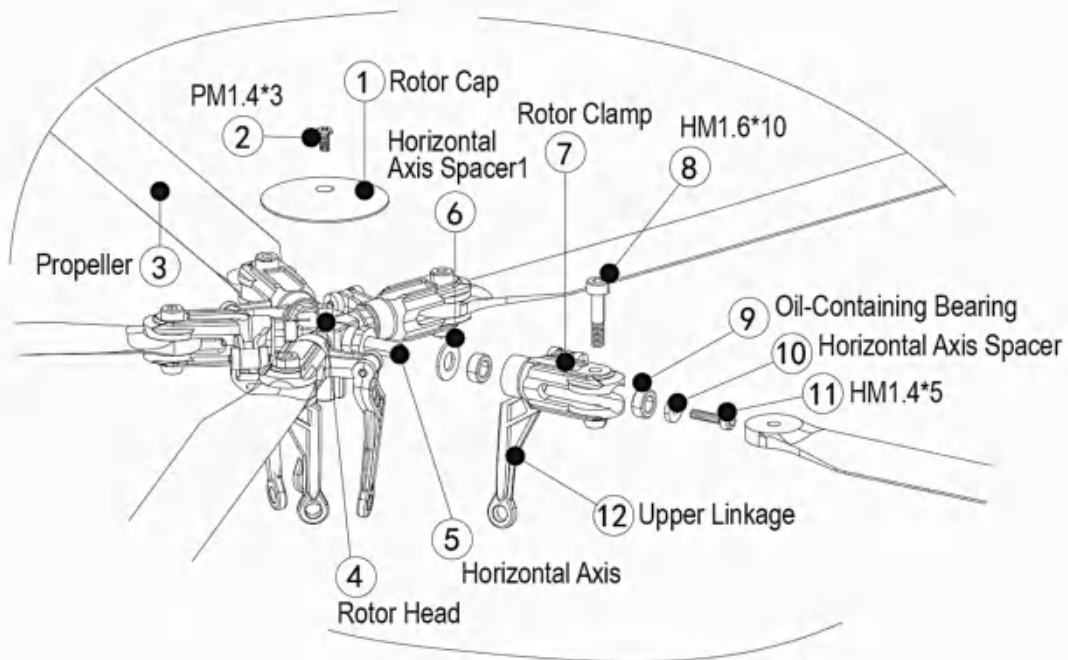

Note: Before flying, please check for any loose screws in all parts, ensure they are tightened, and then proceed with flight operations.

Do not lock the main rotor screws too tightly to keep folding smoothly. If the main rotor screws are too tight, the helicopter will shake when flying.

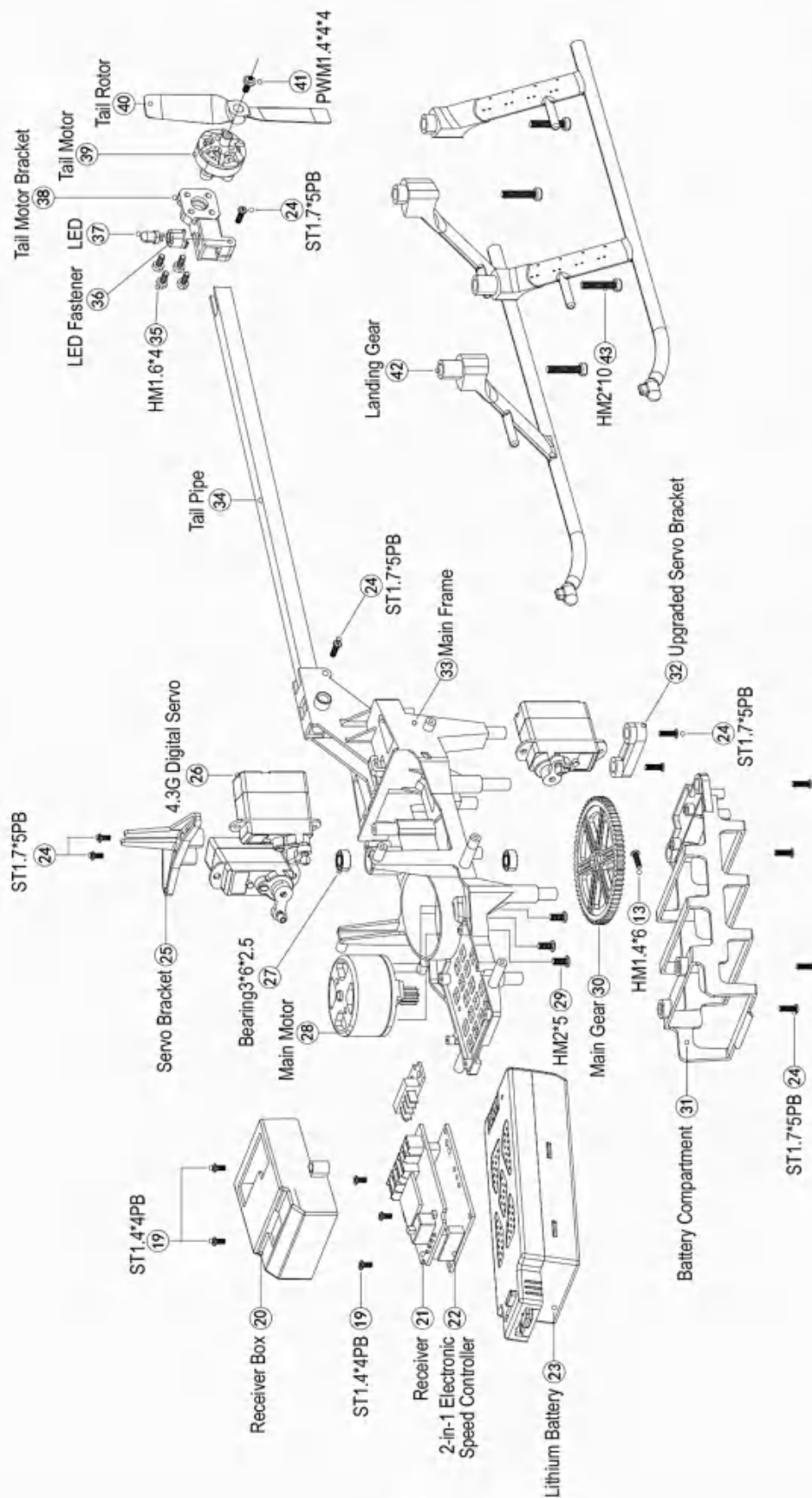

Note: Before flying, please check for any loose screws in all parts, ensure they are tightened, and then proceed with flight operations.

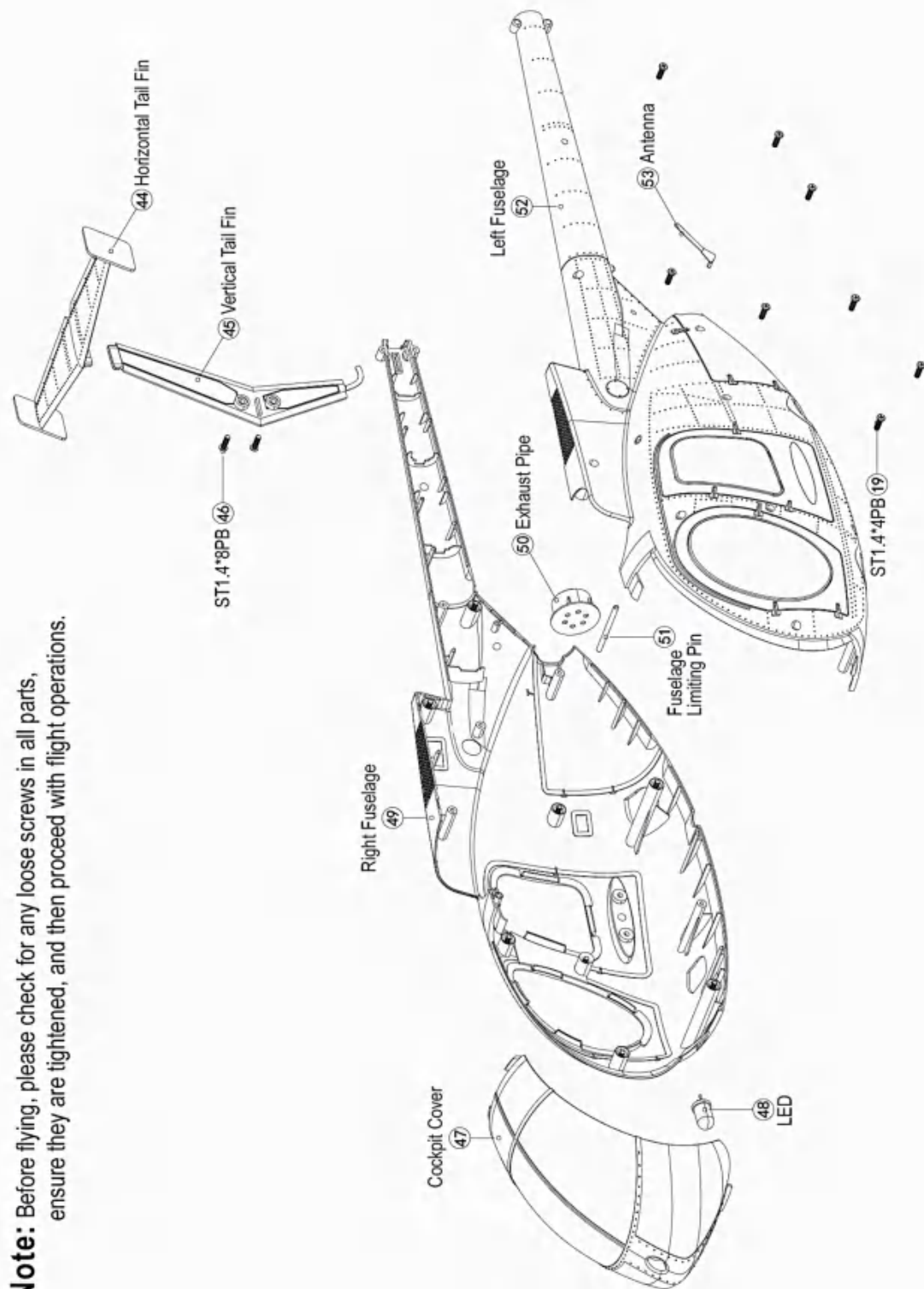

Note: Before flying, please check for any loose screws in all parts, ensure they are tightened, and then proceed with flight operations.

	Problem	Possible Cause	Solution
1	Chopper power on. Taillight on Blinking, no response to operation.	The helicopter without bind with the transmitter.	Bind the transmitter again
2	After turning on the chopper power switch, the chopper Nothing happened.	Check the power supply of helicopter and transmitter; Check the battery's voltage of the helicopter and transmitter; Batteries had a poor connecting.	Check the installation site of Transmitter's batteries; Use full voltage batteries; Install the batteries again; Confirm the batteries have a good connecting.
3	Push the throttle but the motor not at work, the receiver's signal light keep flashing	Helicopter's battery has a low voltage; The lipo battery has a poor connecting.	Charge the battery or change a full charge battery; Connect the battery with receiver again.
4	Turn on the helicopter after bind, the main blade can rotate but the helicopter can not take off	Chopper battery low	Charge the battery or replace it with a fully charged one. The propeller will be reinstalled and turned smoothly.
5	The helicopter is violently shaking	Main rotor deformed cross shaft bent tail rotor bent Blade clamp screws are too tight to cause the main blade can not rotate	Change the main blade; Change the cross shaft; Change tail rotor; Loose the blade clamp screw.
6	Helicopter spinning to left after take off.	Tail motor has a poor power; The blades loose; Tail motor was broken.	Check the connection of tail blade and motor shaft. if loose, change tail blade or tail motor.
7	The helicopter has a little yaw:	made a operational error of the trimming button	1.According to its yaw direction, push the trimming button in the opposite direction; 2.Reset the hovering point.
8	The helicopter has a serious yaw.	Aileron Servo Detachment Linkage Detachment	Check the servo if work properly; Check the swash plate; Check the rod sticks if loosing.

C189

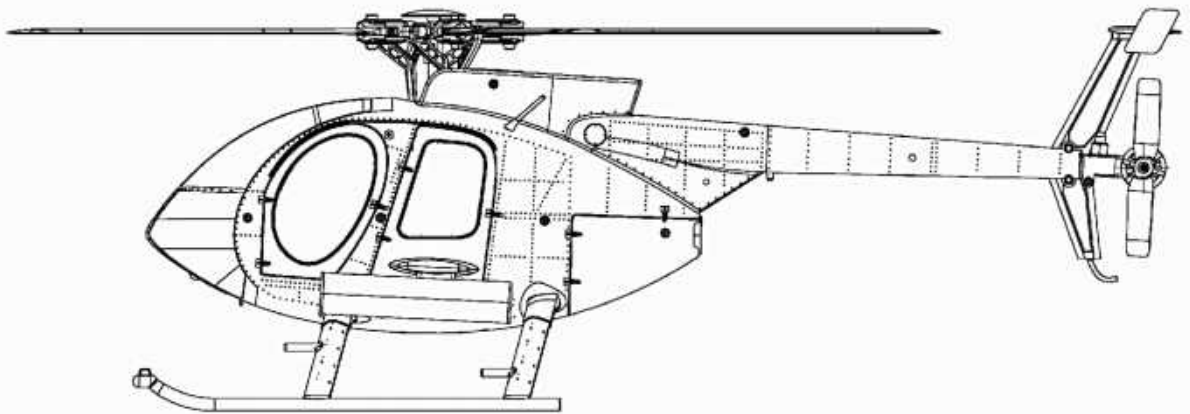

CE FC



RoHS



MADE IN CHINA

