

A3 EVO

User Manual

V1.0 Oct, 2021 Revision

Thank you for purchasing our products. A3 EVO is a high-performance and functional 6-axis gyro system designed for R/C airplanes. In order for you to make the best use of your gyro and to fly safely, please read this instruction manual carefully and set up the device as described below.

IMPORTANT NOTES

- Radio controlled (R/C) models are not toys! The propellers rotate at high speed and pose potential risk. They may cause severe injury due to improper usage. It is necessary to observe common safety rules for R/C models and the local law. Read the following instructions thoroughly before the first use of your gyros and setup the gyro carefully according to this manual. We also recommend that you seek the assistance of an experienced pilot before attempting to fly with our gyros for the first time.
- After power on, A3 EVO needs to perform an accurate gyroscope calibration, keep the airplane stationary after power on and wait while the LED flashes Blue. The LED will stay solid Blue if a slight movement is detected and the calibration will not start until you stop moving the airplane, however, making the airplane level is NOT required during the initialization.
- A stick centering is also required following the gyroscope calibration. Always put all the sticks center (the throttle stick in the lowest position) before power on the airplane, and do not move the sticks until the initialization is done.
- Make sure to check the gyro direction of Aileron, Elevator and Rudder channels after installation and always perform a test of them before each flight. An opposite reaction of the gyro could lead to losing control or even crash!
- It is recommended to use the supplied 3300uF/16V capacitor to get a more stable and secure working voltage for the gyro. The capacitor can be plugged onto any one of the free connectors of the gyro or receiver.

INSTALLATION

Use one of the supplied double-sided tape to attach the gyro to your airplane firmly. For best performance, the gyro should be mounted as close to the C.G. as possible, and the housing edges must be aligned exactly parallel to all three rotation axes of the plane. The gyro can be attached flat or upright, and even upside down, however, you have to ensure that the shorter side with the setting button always points toward the heading direction of the airplane, otherwise the gyro will not work normally in LEVEL and HOVER modes.

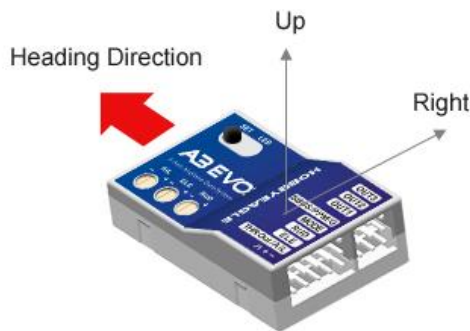

① Flat, face up

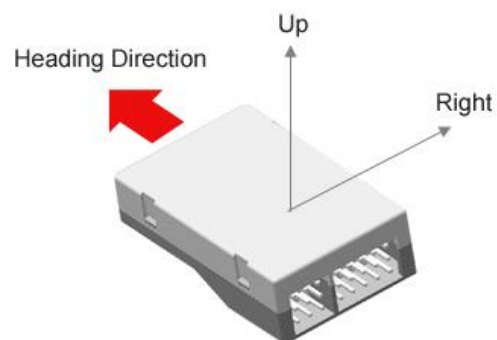

② Flat, face down

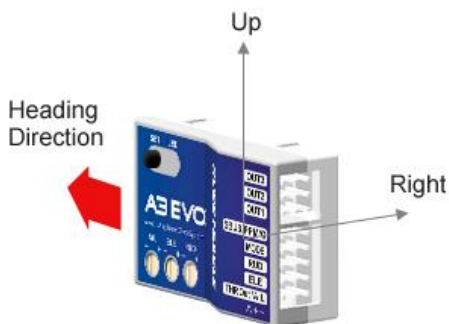

③ Upright, button up

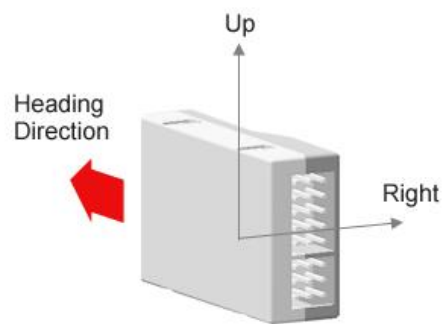

④ Upright Inverted, button down



NOTES

- Never use the hot-melt glue or nylon ties to fix the gyro onto the airplane!
- You need only one piece of the tapes each time, a soft or thick mounting may probably impact the performance of the gyro.
- The gyro is a sensing device, please make enough space around it and keep as far away from other electronic devices or wires as possible.

CONNECTION

⚠ NOTES

- [MODE] is used for flight mode switching of the gyro, connect it to a 3-way switch channel of the receiver to switch the flight mode in flight.
- [SBUS/PPM/G] is used for remote master gain adjusting, connect it to a proportional channel of a volume or slide lever of the transmitter to tune the master gain in flight.
- The ESC or throttle servo is connected to the throttle channel of the receiver directly without passing through the gyro.
- Pay attention to the polarity of the plugs. The orange signal line must always be on the top and the brown on the bottom.

STANDARD PWM RECEIVER CONNECTION

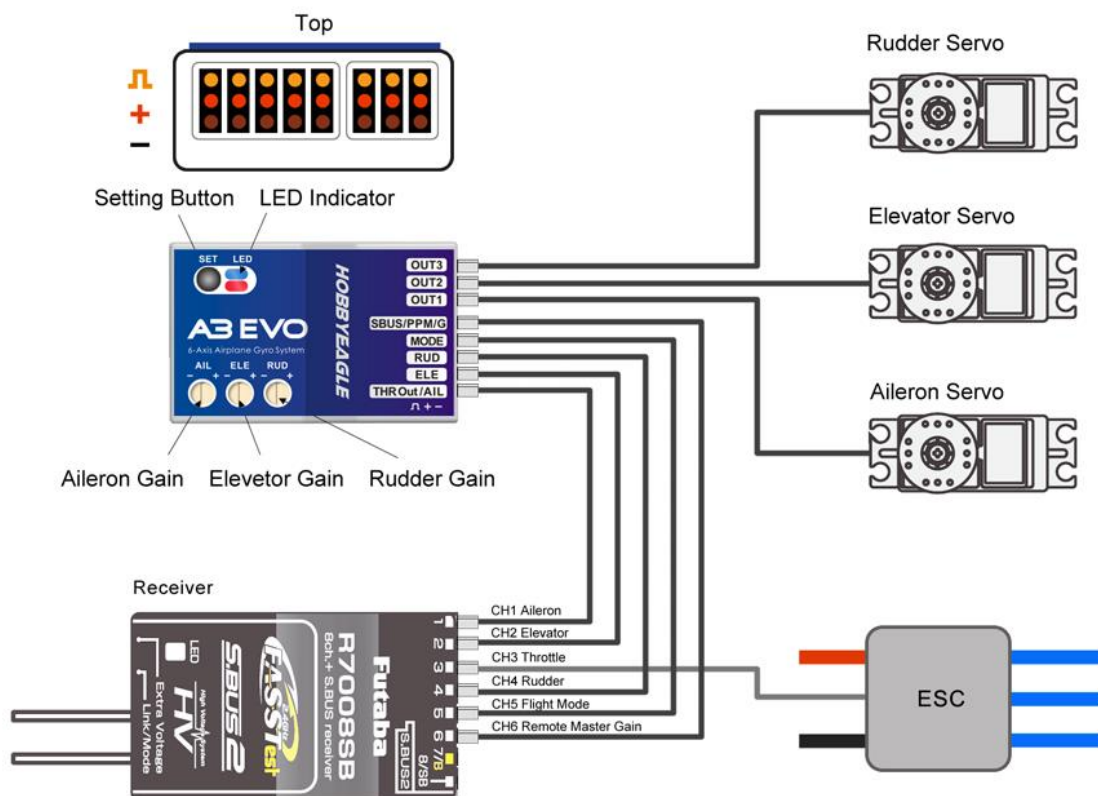

SINGLE-LINE RECEIVER CONNECTION

A3 EVO supports PPM and Futaba S.Bus serial receivers which allows you to connect the gyro to the receiver with one single wire. When using a specific type of these receivers the appropriate type of receiver channel allocation will be preset in the A3 EVO. Please refer to the table below and check if your

radio transmits the channels in the correct order. If you use a standard PWM receiver with standard wiring layout the channel mapping does not apply. When A3 EVO is operating in single line receiver mode, the [THR Out/AIL] can be used as the throttle output channel for the ESC or the throttle servo if a mini receiver is being used which has no additional output connectors.

 Please note that the Remote Master Gain is disabled in single line mode as default. Choose a channel number for gain channel in item 11 of the *Setup Menu* to activate this feature if needed.

Table 1: Default Channel Mapping for Single Line Receivers

Serial Receiver Protocol	AIL	ELE	THR	RUD	MODE	GAIN
PPM Receiver	CH1	CH2	CH3	CH4	CH5	-
Futaba S.Bus (FrSky SBUS or WFLY WBUS)	CH1	CH2	CH3	CH4	CH5	-

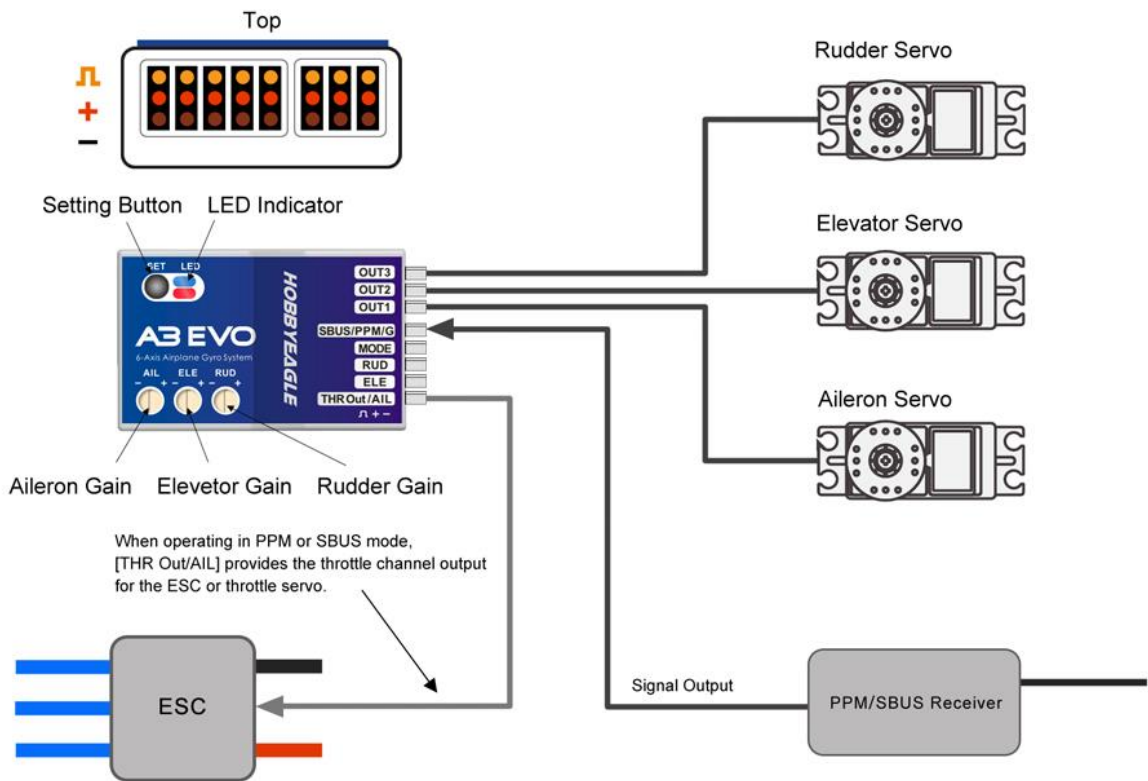

FLIGHT MODES

A3 EVO provides 4 flight modes which can be switched by a 3-position switch of the transmitter during flight. We have provided you with 4 different mode allocation corresponding to the 3 positions of the switch in Item 7 of the *Setting Menu*, the default setting is **MODE 1: NORMAL – LEVEL – HOVER**. The color of the LED shows the current flight mode of the gyro while in use.

Table 2: Colors of the LED for Flight Modes

	Solid Blue	NORMAL Mode
	Solid Red	LEVEL Mode
	Solid Blue&Red	HOVER Mode
	LED Off	GYRO OFF Mode

Table 3: Flight Mode Allocations

Mode	Position-1	Position-2	Position-3
MODE-1 *	NORMAL	LEVEL	HOVER
MODE-2	NORMAL	GYRO OFF	LEVEL
MODE-3	NORMAL	GYRO OFF	HOVER
MODE-4	LEVEL	GYRO OFF	HOVER

1. GYRO OFF MODE

When operating in *GYRO OFF* mode the gyro will be deactivated completely, and the airplane will be completely under the control of your transmitter as it was before installing the gyro. This mode is usually used for testing purpose only.

2. NORMAL MODE

The *NORMAL* mode, also known as the '*Rate mode*', is the most basic function of the gyro. It works based on the rotation rate control of each axis of the airplane. When operating in this mode, the gyro will only correct currently occurring rotational movements, a momentary reaction will be applied to the servos when the airplane rotating on corresponding axis, after rotation the servos will move back to their neutral position as soon as the airplane standing still immediately. The *NORMAL* mode can be used with nearly any size and type of airplanes. It can effectively improve the stability and precision of the airplane and reduce the stall point specially.

3. LEVEL MODE

The *LEVEL* mode is also known as the '*Auto-Level mode*', '*Auto-Balance mode*' or '*Horizon mode*'. When operating in this mode, the airplane will be brought to horizontal position automatically when releasing the sticks. Different from the *ANGLE* mode, there is no maximum angle limitation in this mode and the airplane will be stabilized only when there is no specific control input from aileron and elevator sticks. This mode can be used if the pilot becomes disoriented and would like to save the airplane from crashing.

4. HOVER MODE

The *HOVER* mode, also known as the '*Auto-Hover mode*', provides the same functionality as the *LEVEL*

mode. The only difference is that when you release the sticks, the airplane will be brought to vertical position (nose up) and keeps hovering. This mode is designed to help you to learn hovering maneuver and reduce the probability of crashing.

GAIN ADJUSTMENT

BASIC GAIN

There are 3 trimming potentiometers on the front of the A3 EVO. They are used to adjust the basic gain of the gyro for Aileron, Elevator and Rudder separately. Clockwise for increase, anticlockwise for decrease. Basic gain determines the momentary reaction strength of the gyro. In general, the higher the gain the harder the airplane will stop after rotation and the more stable and precise the airplane will fly. But if the gain is too high the airplane will tend to oscillate at high frequency on the corresponding axis. If too small, the operation and stability will not be so good and the airplane does not stop precisely and overshoots. The gyro will be deactivated completely if you turn the basic gain to 0%.

For the first flight test it is recommended to start with a lower basic gain setting (e.g. 30%) and switch the gyro to *NORMAL* mode. In case the airplane starts to oscillate in flight then reduce the gain of the corresponding axis. If the control feels weak and imprecise and does not hold position when stopping then increase the gain, according to this approach, fine tune the basic gain until you get the best performance.

REMOTE MASTER GAIN

The [SBUS/PPM/G] is used to control the remote master gain for parallel PWM receiver. You can make a linear adjustment by using a volume or slide lever on your transmitter or make a 3-level gain selection using a 3-position switch. This function is optional, the master gain will always default to 100% if you do not connect it. Master gain will not affect the basic gain setting on the gyro.

SETTING METHOD

Setup Menu

To get into the *Setup Menu*, press and hold the button for about 2 seconds until the LED starts flashing Blue and Red quickly. The *Setup Menu* contains 11 setting functions which normally only need to be setup once after installation.

Function Selection

In the *Setup Menu*, the LED will flash Blue and Red several times every 3 seconds in a loop and the number of times LED flashes shows at which function item you are currently. For example, one Blue and Red flashing means the first setting "*Aileron Gyro Direction*", after waiting about 3 seconds, a twice Blue and Red flashing means the second setting "*Elevator Gyro Direction*", and so on.

Option Switching

When you reach the function that you wish to operate in, short press the button to get into it. After entering in, the current selected option is indicated by the color of the LED. Each short press of the button advances the option to the next value. After you finish making your selection, just wait for 5 seconds until the LED starts blink quickly which indicates that the modified is saved and then you will be brought back to the *Setup Menu* level automatically. If you do not want to change anything, just wait for timeout without any operation.

Exit of Menu

To exit the menu just keep the button pressed for 2 seconds again until the LED starts flashing Blue and Red quickly.

SETUP MENU TABLE (* is the default setting)

Functions	LED Status	Solid Blue	Solid Red	Blue&Red	Blue Flashing	Red Flashing	Blue&Red Flashing
1 Aileron Gyro Direction	1 flash	Normal *	Reversed				
2 Elevator Gyro Direction	2 flashes	Normal *	Reversed				
3 Rudder Gyro Direction	3 flashes	Normal *	Reversed				
4 Wing Type	4 flashes	Standard *	Delta-wing	V-Tail			
5 Receiver Type	5 flashes	PWM *	PPM	SBUS			
6 Mount Orientation	6 flashes	Flat *	Flat Inverted	Upright	Upright Inverted		
7 Flight Mode Allocation	7 flashes	Mode-1 *	Mode-2	Mode-3	Mode-4		
8 Servo Frequency	8 flashes	50Hz *	100Hz	200Hz			
9 Level Calibration	9 flashes						
10 Hover Calibration	10 flashes						
11 Remote Master Gain	11 flashes	Disabled *	CH6	CH7			

1-3. GYRO DIRECTION

The top 3 items of the *Setting Menu* is used to reverse the gyro direction for *Aileron*, *Elevator* and *Rudder*. The color of LED shows you the gyro direction currently selected, the default setting is *Normal (Solid Blue)*. Each short press of the button will switch between *Normal* and *Reversed*. After you finish making your selection, just wait for 5 seconds until LED starts blink quickly which indicates that the modified is saved and then you will be brought back to the *Setup Menu* level automatically.

LED Color	Description
Solid Blue	Normal (default)
Solid Red	Reversed

! VERY IMPORTANT!

It is extremely important to make sure that the gyro reacts in the correct direction for each channel before flight. An opposite reaction of the gyro could lead to losing control or even crash!

Check the gyro direction for Aileron Quickly move the right wing downward around the roll axis, the right aileron surface should flap down and the left flap up as shown below.

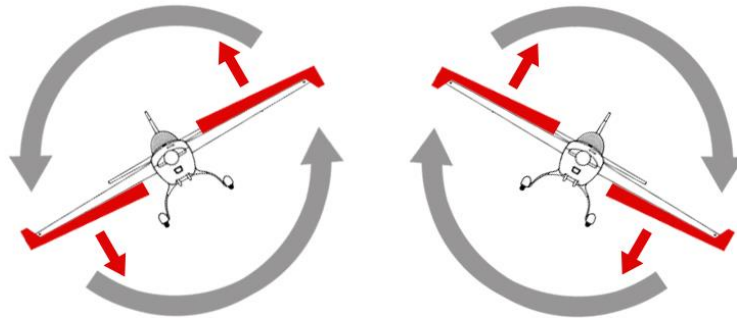

Check the gyro direction for Elevator Quickly move the nose of the airplane downward around the pitch axis, the elevator surface should flap up as shown below.

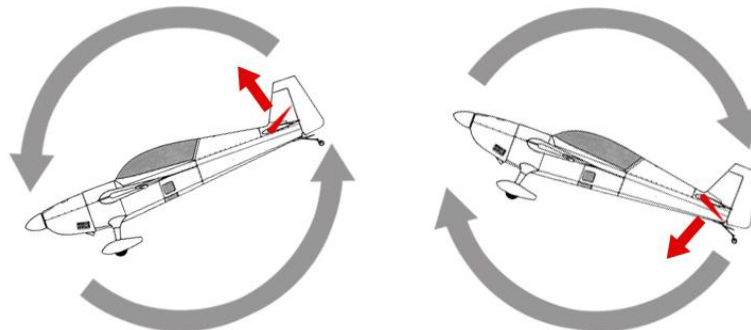

Check the gyro direction for Rudder Quickly move the nose of the airplane to the left around the yaw axis, the rudder surface should flap right as shown below.

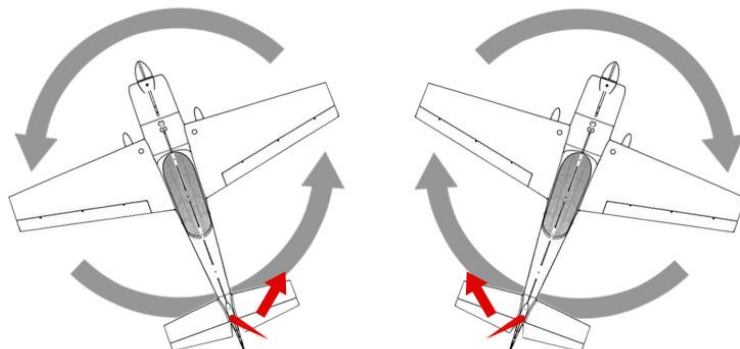

4. WING TYPE

The 4th item of the *Setup Menu* is used to setup the wing type. A3 EVO supports standard fixed-wing, flying-wing (delta-wing) and V-tail. The color of LED shows you the wing type currently selected. The default setting is *Standard (Solid Blue)*, each short press of the button will switch to the next type. After you finish making your selection, just wait for 5 seconds until LED starts blink quickly which indicates that the modified is saved and then you will be brought back to the *Setup Menu* level automatically.

LED Color	Description
Solid Blue	Standard (default)
Solid Red	Flying-wing (Delta-wing)
Blue & Red	V-Tail



NOTES

- Make sure that there are no mixing functions active on your transmitter. Have a look at the radio's servo monitor and verify that each stick controls only one output channel.
- If two aileron servos are being used, please connect a Y-extended lead to [OUT1].
- Most flying-wings have no rudder, in this case, [RUD] is unnecessary to connect.

Servo Connection Illustration

Standard Wing Type

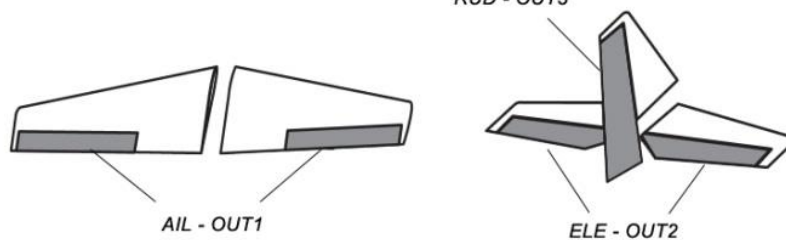

Flying Wing (Delta)

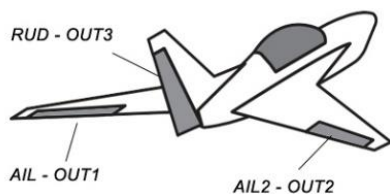

V-TAIL

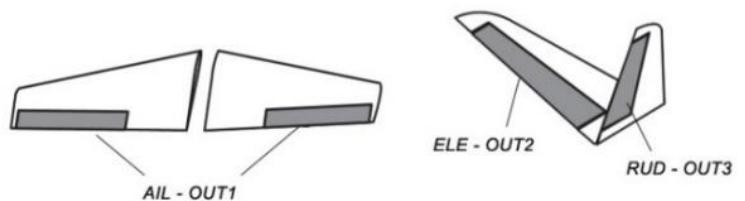

5. RECEIVER TYPE

The 5th item of the *Setup Menu* is used to choose the receiver type. The color of LED shows you the receiver type currently selected. The default setting is *PWM Receiver (Solid Blue)*, each short press of the button will switch to the next value. After you finish making your selection, just wait for 5 seconds until the LED starts blink quickly which

LED Color	Description
Solid Blue	PWM Receiver (default)
Solid Red	PPM Receiver
Blue & Red	Futaba S.Bus Receiver

indicates that the modified is saved and then you will be brought back to the *Setup Menu* level automatically.

Restart the gyro to make the new receiver type setting take effect!

6. MOUNT ORIENTATION

The 6th item of the *Setup Menu* is used to setup the mounting orientation of the gyro. The color of LED shows you the orientation currently selected. The default setting is *Flat, face up (Solid Blue)*, each short press of the button will switch to the next value. After you finish making your selection, just wait for 5 seconds until LED starts blink quickly which indicates that the modified is saved and then you will be brought back to the *Setup Menu* level automatically.

LED Color	Description
Solid Blue	Flat, face up (default)
Solid Red	Flat, face down
Blue & Red	Upright, button up
Blue Flash 	Upright Inverted

The setting here should be the same as the mounting orientation of your unit installed in the airplane, otherwise the gyro will not work normally.

7. FLIGHT MODE ALLOCATION

The 7th item of the *Setup Menu* is used to select the flight mode allocation definition for the 3-position switch. The color of LED shows you the orientation currently selected. The default setting is *Mode-1 (Solid Blue)*, each short press of the button will switch to the next value. After you finish making your selection, just wait for 5 seconds until LED starts blink quickly which indicates that the modified is saved and then you will be brought back to the *Setup Menu* level automatically.

LED Color	Description
Solid Blue	MODE-1 (default)
Solid Red	MODE-2
Blue & Red	MODE-3
Blue Flash 	MODE-4

See “*Table 3: Flight Mode Allocations*” on page 5 for description of each mode.

8. SERVO FREQUENCY

The 8th Item of the *Setup Menu* is used to select the working frequency of the servos. The color of LED shows you the frequency currently selected. The default setting is *50Hz (Solid Blue)*, each short press of the button will switch to the next value. After you finish making your selection, just wait for 5 seconds until LED starts blink quickly which indicates that the modified is saved and then you will be brought back to the *Setup Menu* level automatically.

LED Color	Description
Solid Blue	50Hz (default)
Solid Red	100Hz
Blue & Red	200Hz

Please note that the analog servos can only work with 50Hz. If you do not know what the maximum update rate that is tolerated by your servos never use more than 50Hz. The higher the frequency the better it is for the flight performance of the gyro but you must check the servo specifications before increasing the setting. Otherwise, the servos may get damaged!

9. LEVEL CALIBRATION

When flying in *LEVEL* mode, A3 EVO needs to know the angle of the airplane in both roll and pitch directions, this is achieved by calculating the attitude of its own. A small angle deviation caused by installation can lead to an unexpected behavior when flying in *LEVEL* mode. For this reason, a level calibration is recommended to offset the error caused by installation and to establish a proper level reference of your airplane after installing the gyro.

Before calibrating, the airplane should be placed on the horizontal ground and make the wing parallel to the ground. Make the airplane slightly nose-up because a certain elevation angle is usually required to maintain level flight for most airplanes. Short press the button when you reach the 9th item of the *Setup Menu*, then LED will start blink Blue rapidly for several seconds, do not move the airplane and keep its attitude until the calibration is done.

10. HOVER CALIBRATION

As a same reason, a hover calibration is recommended to perform after installation if you want to fly with *HOVER* mode. The procedure is quite similar to that of level calibration. The only difference is that before calibrating, you need to lift the airplane and make it vertical to the ground instead of putting it on the ground.

Short press the button when you reach the 10th item of the *Setup Menu*, then LED will start blink Blue rapidly for several seconds, do not move the airplane and keep its attitude until the calibration is done.

11. REMOTE MASTER GAIN

The 11th item of the *Setup Menu* is used to enable or disable the remote master gain function for SBUS or PPM receiver mode. The master gain is disabled as default when leaving the factory, you need to choose either channel 6 or channel 7 as the gain channel to activate this feature if needed.

LED Color	Description
Solid Blue	Disable (default)
Solid Red	Channel 6
Blue & Red	Channel 7

* FACTORY RESET

To restore the gyro to factory default settings, press and hold the button while turn on the power of the gyro, release it when LED starts flash Blue and Red. (FYA: the button needs to be hold for more than 4 seconds), after successfully entering the program the LED will remain flashing Blue, press and hold the button again for about 2 seconds until the LED starts flash Blue quickly, release the button to confirm the

reset. After a successful reset the gyro will start the initialization automatically.

★ ACCELEROMETER CALIBRATION

Before leaving the factory, every unit has been carefully tested and calibrated. Usually, you do not need to perform a calibration of the accelerometer during use. However, in some specific cases, we would suggest you re-calibrate the accelerometer to obtain better performance, these include temperature changes those will probably cause the mechanical characteristics changes of the sensor, or replacement of new sensor, etc. The calibration should be done on a horizontal desktop and the gyro needs to be removed from the airplane.

Entering the Calibration Program

To access the accelerometer calibration program, press and hold the button while turn on the power of the gyro, release it when LED turns Blue and Red.







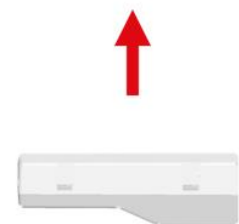

Calibration Steps

A3 EVO uses a quick approach for accelerometer calibration, there are only 2 steps corresponding to both sides of Z axis of the unit required to be calibrated. Each step will take about 2 seconds. While calibrating, the LED will flash Blue several seconds and then light up solid in Blue. Do not move the gyro until the calibration is done.

- ① Put the gyro flat and face up on the table and make it parallel to the desktop. short press the button, do not move the gyro while the LED is flashing Blue quickly.
- ② Put the gyro flat and face down on the table and make it parallel to the desktop, short press the button, do not move the gyro while the LED is flashing Blue quickly.
- ③ After you have finished the 2 steps above, the LED will flash Blue and Red once which indicates that the calibration is complete, after a successful calibration the gyro will start the initialization automatically.

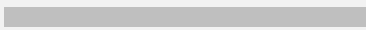

LED DESCRIPTIONS

	Blue, Flashing	Power-on initialization and self-test
	Solid Blue	NORMAL Mode
	Solid Red	LEVEL Mode
	Solid Blue&Red	HOVER Mode
	LED Off	GYRO OFF Mode
	Red, Slow Flashing	No receiver signal detected
	Blue, Fast Flashing	Calibrating or testing
	Red, Fast Flashing	Gyroscope sensor error

SPECIFICATIONS

Main Controller:	AVR MCU	Sensor:	MEMS 6-axis sensor
Gyro Scale Range:	$\pm 2000\text{dps}$	Accel Scale Range:	$\pm 4\text{g}$
PWM Output:	Limit: 970uS to 2070uS, Neutral: 1520uS		
Input Voltage:	4.8V to 8.4V (H.V. 2S Lithium Battery Supported)		
Operating Temperature:	-10°C to 50°C		
Size:	43 × 27 × 14mm	Weight:	10g (excluding wires)