

# TAUMAC™

YOUR AUTOMATION SOLUTION

## TAUWELD 200J

### User and maintenance manual

Translation of the original instructions



**Laser Welding machine**

**Serial**

**TAUWELD 200J**

**Model**

**TAUWELD 200J**

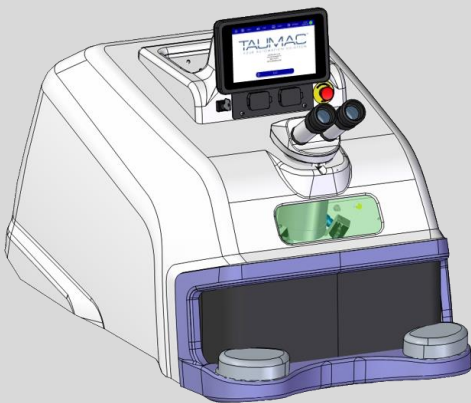

**Serial numbers**

**All**

**Year of manufacture**

**2022**

**Manual code**

**UMS034**

**Review / date**

**0.0 / 04/11/2022**



## 1 General index

	Tittle	Page
1	<b>General index .....</b>	<b>3</b>
2	<b>Warranty and liability .....</b>	<b>4</b>
3	<b>Use of the manual.....</b>	<b>6</b>
4	<b>General instructions.....</b>	<b>9</b>
5	<b>Characteristics and technical data .....</b>	<b>25</b>
6	<b>Transport and installation .....</b>	<b>34</b>
7	<b>Operation .....</b>	<b>43</b>
8	<b>Operation instructions .....</b>	<b>64</b>
9	<b>Maintenance .....</b>	<b>87</b>
10	<b>Storage conditions of the machine .....</b>	<b>95</b>
11	<b>Disassembly of the machine .....</b>	<b>96</b>
12	<b>Support service.....</b>	<b>98</b>
13	<b>Summary and index of figures .....</b>	<b>99</b>
	 Annexes	
A1	<b>Copy of EC Declaration of conformity</b>	
A2	<b>Delivery record for the safety keys of the machine</b>	

## 2 Warranty and liability

### 2.1 Warranty

This Warranty covers the product it accompanies at the time of purchase.

This Warranty guarantees the product against any material or manufacturing faults for a period of THREE YEARS from the original date of purchase.

Should any material or manufacturing defects be found during the warranty period, we will provide to repair or replace (at our discretion) the product or its defective components according to the terms and conditions listed below, free of any charges for labor costs or spare parts. Our support service reserves the right to replace defective products or their components with new or overhauled products or parts. All replaced products and components will become property of Taumac S.r.l. .

### 2.2 Conditions

Repairs under warranty will be performed only if the defective product is presented within the warranty period, along with the original sale invoice or a purchase receipt (indicating the date of purchase, the type of product and the name of the dealer).

Taumac S.r.l. reserves the right to refuse repairs under warranty in the absence of the aforementioned documents or if the information they feature is incomplete or illegible. This Warranty will cease to apply if the indication of the model or serial number on the product have been changed, cancelled, removed or have become illegible.

This Warranty does not cover the costs and risks involved in transporting your product to our FACILITIES.

The following are excluded from this Warranty:

- Periodic maintenance operations and repairs or replacements of parts due to wear and tear;
- Consumption materials (components which foreseeably require periodic replacing during the lifespan of a product, such as tools, lubricants, filters, etc.).
- Damage or faults due to incorrect operating, use or treatment of the product, for different purposes than normal professional use;
- Damage or modifications to the product caused by incorrect use, including:
  - Treatments that cause physical, aesthetic or superficial damage or alterations;
  - Incorrect installation or use of the product for different purposes than those it is designed for, or failure to observe instructions for its installation and use;
  - Incorrect maintenance of the product, non-compliant with instructions for its correct maintenance;
  - Installation or any use of the product that is not in compliance with technical and safety laws of the Country where the product is installed or used;
  - Conditions or defects in the systems the product is connected to or in which it is incorporated;
  - Repairs or attempted repairs by unauthorized staff;
  - Adjustments or changes to the product carried out without prior written authorization from the manufacturer, update of the machinery exceeding the technical specifications and functions described in the instructions manual, or changes made to the product to make it compliant with different national or local technical or safety laws than those for which the product was specifically designed and built;
  - Negligence;
  - Accidents, fires, liquids, chemical substances or other types of substances, flooding, vibrations, overheating, inadequate ventilation, excessive or incorrect electrical supply, radiations, electrostatic discharge, including lightning and other external forces or sources of impact.

### 2.3 Exclusions and restrictions

With the exception of the above, Taumac S.r.l. does not release any warranty (explicit, implicit, statutory or of any other nature) for the product in terms of quality, performance levels, precision, reliability, suitability for specific uses or other aspects.

If this exclusion not admissible, fully or partially, on the basis of currently applicable laws, Taumac S.r.l. excludes or restricts its warranties to the maximum limit allowed by applicable laws.

Any warranty that cannot be fully excluded will be restricted (according to terms allowed by applicable laws) to the duration of the present Warranty.

The only obligation held by Taumac S.r.l. in the framework of this Warranty consists of repairs or replacements of products based on the present warranty terms and conditions. Taumac S.r.l. declines any liability for losses or damage concerning products, services, the present Warranty or other aspects, including economic or intangible losses – the price paid for the product – loss of profits, income, data, employment or use of the product or of other associated products – indirect, incidental or consequential losses or damage. This is also valid for losses and damage deriving from:

- Compromised functioning or breakdowns of the product or of associated products due to defects or lack of availability while under assessment in the facilities of Taumac S.r.l. or other authorized support centers, with consequent downtime, loss of production time or interruptions in operations;
- Imperfect performances of the product or associated products.

This is also valid for losses and damage in the context of any legal theories, including negligence and other illegal acts, contractual violations, explicit or implicit warranties and strict liability (including cases in which Taumac S.r.l. or the support center have been warned of the possibility of such damage occurring).

If currently applicable laws prohibit or restrict these liability exemptions, Taumac S.r.l. excludes or restricts its liability to the maximum limit allowed by applicable laws.

Some nations, for example, prohibit the exclusion or restriction of damage due to negligence, grave negligence, intentional non-compliance, fraud and similar acts. In the framework of this Warranty, in no event will the liability held by Taumac S.r.l. be greater than the price paid for the product, notwithstanding that if applicable laws require higher liability limits, these limits will be applied in compliance with the law.

#### **2.4 Reserved legal rights**

Applicable national laws grant (statutory) legal rights to purchasers in the context of consumer product sales.

This Warranty does not affect purchaser rights set by currently effective laws, nor rights that cannot be excluded or restricted, nor the client's rights in relation to the dealer. The client will decide, at his sole discretion, whether to enforce the rights he is entitled to.

#### **2.5 Seals**

Seals are present in specific points of the welding machine. These seals must not be broken or removed for any reason. The seals parts can be opened only and exclusively by Taumac S.r.l. or by the authorized support center.



**INFORMATION!:** *Breaking or removal of the seals placed by the manufacturer on the welding machine will result in immediate forfeit of the warranty.*



**WARNING!:** *Only authorized, qualified and trained personnel is allowed to access internal parts of the machine.*

### 3 Use of the manual

This manual was prepared by the Manufacturer and is an integral part of the supply of the machinery.

The information featured in the TAUWELD 200J, manual addresses the staff in charge of operating and maintaining the machine.

The manual offers information that all qualified staff must mandatorily be familiar with, and which allows for use of the machine in safe conditions.



***OBLIGATION! All relevant staff, as a result of its tasks and responsibilities, must read and understand the contents of this manual before installing, using or performing any other operation on the machine!***

#### 3.1.1 Definitions

- **Safety component:** a component or device used to ensure safety functions; failures or malfunctions of these components can jeopardize the health and/or safety of exposed persons (e.g. fixed and mobile guards, electronic safety devices, etc.);
- **Protection device:** device (other than guards) designed to reduce risks, either by itself or in combination with guards;
- **Operator:** individual(s) in charge of installing, running, regulating, cleaning, repairing or moving a machine or in charge of its maintenance;
- **Hazard:** a potential source of injuries or harm;
- **Exposed person:** any person located fully or partially within a hazardous area;
- **Guard:** element of the machine used specifically to ensure protection via a material barrier;
- **Risk:** combination of the probability and gravity of injuries or harm caused by a hazardous situation;
- **Residual risk:** risk that remains after the implementation of protection measures;
- **Expected use:** use of the machinery compliant with information provided in the instructions for use;
- **Reasonably foreseeable incorrect use:** different use of the machine than that indicated in the instructions for use, but deriving from easily predictable human behavior;
- **Hazardous area:** any area inside and/or near the machine in which the presence of a person constitutes a risk for his/her health and safety.

## 3.2 Structure of the manual

### 3.2.1 Division of the manual

This manual is divided into chapters. Each chapter may in turn be divided into paragraphs. The lower external margin of each page indicates the page number and the total number of pages in the manual.

A general summary is included at the end of the manual for quick consultation.

### 3.2.2 Illustrations and tables

Illustrations and tables are normally included within the text. When this is not possible, they are linked to the page and listed as a connected illustration or table. All tables and illustrations are numbered and feature a caption (Tab. 2.2-1, Fig. 2.2-1, etc.).

### 3.2.3 Annexes

We intend as annexes all technical documents that are an integral part of the user and maintenance manual, such as electrical and pneumatic diagrams, declarations of conformity for components, technical specification sheets, etc. These documents are included at the end of the manual (after the summary and the illustrations index).

## 3.3 Units of measurement

The following units of measurement have been used in this manual, as defined by the International System (S.I.), under the ISO 80000-1 standard. The units of measurement normally used in this manual are:

- **Linear dimensions** – The chosen unit of measurement for length is the meter, symbol [**m**], or its submultiples (centimeters and millimeters, i.e. [**cm**] and [**mm**]). The inch is used in some cases;
- **Time** - The chosen unit of measurement for time is the second [**s**]. When convenient, the manual may also use minutes [**min**] and/or hours [**h**];
- **Mass** - The chosen unit of measurement for mass is the kilogram [**kg**]. When convenient, the manual may also use grams [**g**];
- **Electric current intensity** – Electric current intensity is measured in Ampere [**A**];
- **Thermodynamic temperature** – According to the SI system, the essential unit of measurement for thermodynamic temperature is the Kelvin degree [**K**]. The temperature unit generally used in this manual is the Celsius degree [**°C**]. The temperature will be left in Fahrenheit degrees [**°F**] only when specific sections refer to parts for which the manufacturer is supplying technical specifications;
- **Light intensity** – Light intensity per surface unit is measured in [**lux**];
- **Plane angle** – Based on international standards, plane angles are measured in radians [**rad**]. This manual uses sexagesimal degrees, according to the ratio:  $360^\circ = 2\pi$  [**rad**].

### 3.3.1 Derived units

Derived units of measurement are all based on the essential units described above. In addition to units derived from essential metric units, some essential Anglo-Saxon units and their derived units may be used in certain parts of the manual.

### 3.4 Conservation of the manual

#### 3.4.1 How to conserve the manual

This manual, the original copy of the declaration of conformity and all the technical annexes must be stored with care for the entire lifespan of the machine, including the disassembly phase.

#### 3.4.2 Where to store the manual

The manual should be kept in a dry place near the machine and must in any case always be available for consultation by the staff in charge of running and monitoring the machine.

#### 3.4.3 How to reproduce the manual

This manual can be photocopied only from the original copy, given that photocopies made from other copies will decrease the clarity of the images and therefore of the information.



**PROHIBITION!:** *Reproducing this manual is permitted only for the purpose of making a spare copy.*

*In compliance with the law, Taumac S.r.l. reserves ownership of this manual, prohibiting its transfer to third parties and/or its unauthorized reproduction.*

#### 3.4.4 What to do in the event of loss or damage

If this manual is damaged or lost, the Client can ask for a certified copy. When forwarding the request, please indicate the code and version of the manual. This data can be found at the top of each page (Fig. 3-1).

code: UMS034	revisew: 0.0	date: 04/11/2022
--------------	--------------	------------------

Fig. 3-1 - Manual ID data

#### 3.4.5 What to do if ownership of the machine is transferred

If the machine is sold to a third party, the manual must be delivered to the new owner.

#### 3.4.6 What to do in the event of changes to the machine

Before making any changes to the machine, contact the manufacturer or the dealer in order to receive the necessary clarifications on feasibility of the operations without altering the machine characteristics or safety conditions.

If substantial changes are made to the machine or its control units, the machine certification and consequently this manual **will no longer be considered valid**.



## 4 General instructions

### 4.1 Working in safe conditions

Safety instructions included in the user and maintenance manual refer to operations which can be performed on the machine.

Safety symbols are included in the text to highlight items which require particular attention. It is essential that these safety instructions be observed at all times. Failure to observe the instructions may cause injuries to persons and/or damage to machinery or to other equipment.

Keeping this in mind, please find below a series of key safety instructions:





- Read and learn this section of the safety instructions before installing, using, maintaining or repairing the machine;
- Read and follow the safety signs included in the text and referring to specific operations;
- When required, wear personal protective equipment (P.P.E.) such as protective glasses, safety gloves and shoes;
- Know and observe the safety instructions provided by Taumac S.r.l. , as well as general standards for prevention of injuries and safety laws.

### 4.2 Safety signs

When pertinent, the symbols illustrated below are used in this user and maintenance manual. These symbols were inserted to warn the staff of hazards or potential sources of danger. **Learn their meaning.**

Failure to pay attention to these symbols may cause personal injuries, death and/or damage to the machine or to equipment.

There are generally three types of signs (Tab. 4-1):

<i>Symbol</i>	<i>Shape</i>	<i>Type</i>	<i>Description</i>
	Framed triangle	<b>Hazard signs</b>	Indicate instructions concerning present or potential hazards
	Barred circle frame	<b>Prohibition signs</b>	Indicate instructions concerning actions that must be avoided
	Full circle	<b>Obligation signs</b>	Indicate information the staff must read and observe
	Circle frame	<b>Information</b>	Indicate useful information, <b>different</b> than the hazard / prohibition / obligation type







Tab. 4-1 – Type of safety signage

According to the information they intend to transmit, the signs may feature a series of symbols to help understand the type of hazard, prohibition or obligation they refer to, via an association of ideas.

### 4.3 Symbols used

The following symbols are used in this manual.

These symbols have been included to help understand performed / described activities; they are generally featured in paragraphs 7.4 and 7.5 and in chapters 8 and 9.

<i>Symbol</i>	<i>Description</i>
	Indicates the use of control devices. May be accompanied by text (e.g.: ON/OFF, Start/Stop), indications on the rotation direction, etc.
	Indicates locking/unlocking, opening/closing, screwing/loosening actions to be performed with specific tools (e.g. wrenches, screwdrivers).
	Indicates operations concerning the tools (assembly, disassembly, replacement).
	Indicates measuring or detection operations (product dimensions, positioning of guides or clamps).
	Indicates regulation operations.
	Indicates the need to perform checks.
	Indicates lubrication operations.

Tab. 4-2 – Symbols used

#### 4.3.1 Hazard signs



**Generic hazard**

*This sign is used to highlight hazardous situations which may cause damage to persons, animals and things. Failure to observe instructions associated with this sign can cause danger.*



**Hazard due to the presence of voltage**

*This sign is used to highlight the danger of electrocution due to direct or indirect contact with live parts of the machine. Failure to observe instructions associated with this sign can cause serious injuries to persons or even their death.*



**Hazard due to laser radiation**

*This sign is used to highlight the danger deriving from the presence of sources of artificial optical radiation. Failure to observe instructions associated with this sign can cause the risk of damage to sight.*



**Danger of burns**

*This sign is used to highlight the danger of burns due to contact with hot surfaces (> 60 °C). Failure to observe instructions associated with this sign can cause the risk of burns to the hands or upper limbs.*



**Danger of explosion**

*This sign is used to highlight the danger of explosion. Failure to observe instructions associated with this sign can cause explosions.*



**Danger of fire**

*This sign is used to highlight the danger of fire. Failure to observe instructions associated with this sign can cause fires.*



**Danger of death**

*This sign is used to highlight situations of grave danger which may cause serious injuries or even death. Failure to observe instructions associated with this sign can cause serious injuries to persons or their death.*

#### 4.3.2 Prohibition signs



**Generic prohibition**

*This sign is used to highlight that certain maneuvers, operations or forms of behavior are not permitted. Failure to observe instructions associated with this sign can cause damage to things, animals, persons.*



**No touching**

*This sign is used to highlight that the operator is not permitted to touch specific parts of the machine. Failure to observe instructions associated with this sign may cause hand injuries.*



**No introducing hands**

*This sign is used to highlight that the operator is not permitted to introduce his/her hands in specific areas. Failure to observe instructions associated with this sign may cause injuries to the hands and upper limbs.*



**No smoking and no use of naked flames**

*This sign is used to highlight that smoking and/or the use of naked flames are not permitted. Failure to observe instructions associated with this sign may cause explosions and/or fires.*



**No extinguishing with water**

*This sign is used to highlight that flames and/or incipient fires must not be extinguished by using water. Failure to observe instructions associated with this sign can cause damage to things, animals, persons.*

### 4.3.3 Obligation signs



**Generic obligation**

*This sign is used to highlight that the operator must observe the specific instructions. Failure to observe instructions associated with this sign can cause damage to things, animals, persons.*



**Mandatory use of specific P.P.E.**

*These signs are used to highlight the mandatory use of specific personal protective equipment during operations. Failure to observe instructions associated with this sign can cause serious injuries or the death of the operator.*



**Mandatory grounding**

*This sign is used to highlight the mandatory connection of the machine to an efficient grounding system. Failure to observe instructions associated with this sign can cause damage to things, animals, persons.*



**Mandatory disconnection of plug from socket**

*This sign is used to highlight the mandatory disconnection of the electrical supply plug before performing any operations. Failure to observe instructions associated with this sign can cause damage to things, animals, persons.*



**Mandatory guard efficiency check**

*This sign is used to highlight a mandatory efficiency check of the guards (removed during maintenance, repairs, cleaning or lubrication operations). Failure to observe instructions associated with this sign can cause damage to things, animals, persons.*



**Obligation to read instructions**

*This sign is used to highlight the obligation to read instructions (the user and maintenance manual, technical diagrams, etc.) before installing, using or performing any other operation on the machine!*

#### 4.4 General information on classification of lasers

Classification of lasers follows this standard:

- CEI EN 60825-1: 2014 Safety of laser products Part 1: Classification of devices and requirements.

##### 4.4.1 Hazard potential of laser classes

The concept of laser is insufficient to describe the hazard presented by a device emitting coherent electromagnetic radiation.

The risk potential can vary greatly according to the device in question and the conditions in which it is used. This is why international laws recommend the assignment of a specific class to each laser system, in order for the danger potential to immediately be clear to all. The higher the class number, the greater the risk level.

##### 4.4.2 Classification obligation

Producers of laser devices can deliver a product to the user only after attributing it to one of the seven classes defined in the standard on lasers (failure to assign a class would result in the user having to follow the strict rules set for class 4).

Class	Risks	Necessary measures
1	Harmless in normal operation conditions <sup>1</sup> .	No necessary measures.
1M	Harmless without optical tools.	Warn individuals using optical tools.
2	Harmless is exposure is temporary.	<ul style="list-style-type: none"> <li>• Do not look directly at the laser ray;</li> <li>• Do not direct the laser towards the face.</li> </ul>
2M	Without optical tools: same as class 2.	Warn individuals using optical tools.
3A	Eliminated.	Treat the same as classes 1m or 2m.
3R	Moderately dangerous.	For use by qualified staff only.
3B <sup>2</sup>	<ul style="list-style-type: none"> <li>• Direct rays are dangerous for the eyes;</li> <li>• Scattered radiation is not dangerous.</li> </ul>	<ul style="list-style-type: none"> <li>• Appoint a head of laser safety;</li> <li>• Delimit the area of use with architectonic elements;</li> <li>• Control access to the area;</li> <li>• Declare the presence of lasers at the entrance;</li> <li>• Allow use by qualified staff only;</li> <li>• Wear protective glasses if necessary.</li> </ul>
4	<ul style="list-style-type: none"> <li>• Rays are dangerous for the eyes and skin;</li> <li>• Scattered radiation is potentially dangerous for the eyes;</li> <li>• Risk of fire.</li> </ul>	<ul style="list-style-type: none"> <li>• Same precautions as per class 3b;</li> <li>• Use the necessary P.P.E.</li> </ul>

Tab. 4-1 – Classification of lasers in compliance with standard CEI EN 60825-1:2014

Based on the active material and the pumping source, the laser can operate continuously (cw = continuous wave, with an emission duration > 0,25 s), in pulsed mode or in repetitive pulsed mode, or can emanate its energy in the form of a single giant pulse.

#### 4.5 Effects of laser radiation on biological tissues

##### 4.5.1 General information

The mechanism by which laser radiation causes damage is similar for all biological systems and can lead to heat interactions, transitory thermoacoustic events, photochemical processes and non-linear effects.

In the event of damage, the level of responsibility of each of these mechanisms can be referred to certain physical parameters of the radiation source, the most relevant of which are the **wavelength**, the **duration of the pulse**, the **dimensions of the image**, the irradiance and the radiant exposure.

<sup>1</sup> In normal conditions of use, class 1 lasers must be safe even in the absence of specific instructions.

<sup>2</sup> If safety depends on imparted instructions, the lack of danger involved in using the device should not be indicated as class 1, but with a declaration of the following kind: "No hazards in the marked area".

In general, in the case of exposures exceeding the threshold, the predominant mechanism mainly depends on the duration of the exposure pulse.

Thus, following an ascending order of duration of the pulse, **the predominant effects in the following time intervals** are:

- **For exposures lasting nanoseconds and lower than one nanosecond**, micro-cavitation, transitory acoustic events and non-linear effects;
- **Between 100  $\mu$ s and a few seconds**, thermal effects;
- **Above approximately 10 seconds**, photochemical effects.

Laser radiation differs from all other known types of radiation due to its high radiance and collimation of the beam.

This fact, together with the high initial energy content, results in the transmission of noteworthy quantities of energy towards biological tissues.

**The main event** in any type of damage caused by laser radiation to a biological system **is the absorption of optical radiation by the system in question**. This absorption occurs on the atomic or molecular level and represents a specific process of the wavelength. Thus, the wavelength determines which tissue may be damaged by a specific laser beam.

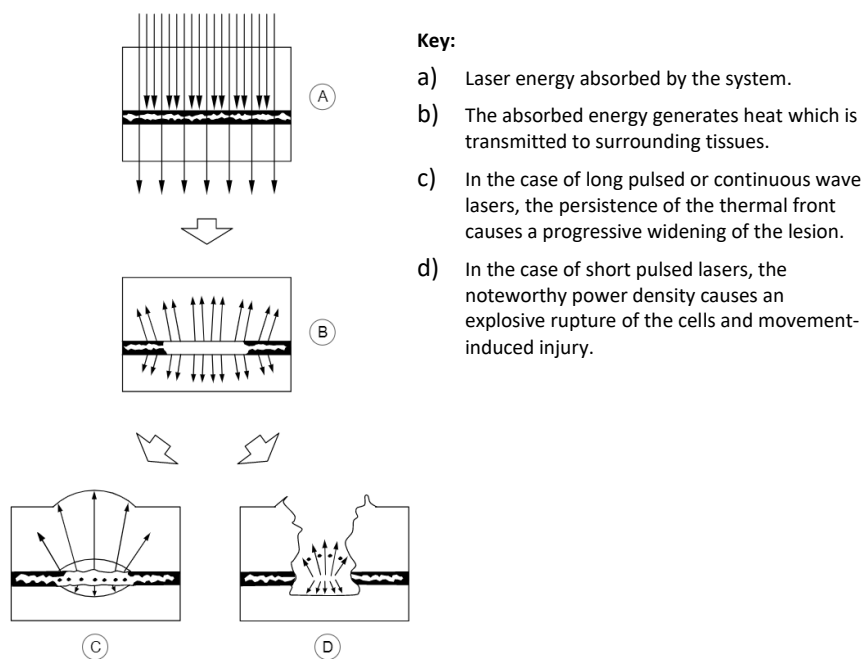

**Key:**

- a) Laser energy absorbed by the system.
- b) The absorbed energy generates heat which is transmitted to surrounding tissues.
- c) In the case of long pulsed or continuous wave lasers, the persistence of the thermal front causes a progressive widening of the lesion.
- d) In the case of short pulsed lasers, the noteworthy power density causes an explosive rupture of the cells and movement-induced injury.

Fig. 4-1 – Examples of absorption of laser radiation based on time of exposure and dimensions of the beam

## 4.5.2 Hazards to the eyes

### 4.5.2.1 Physiology of the eye

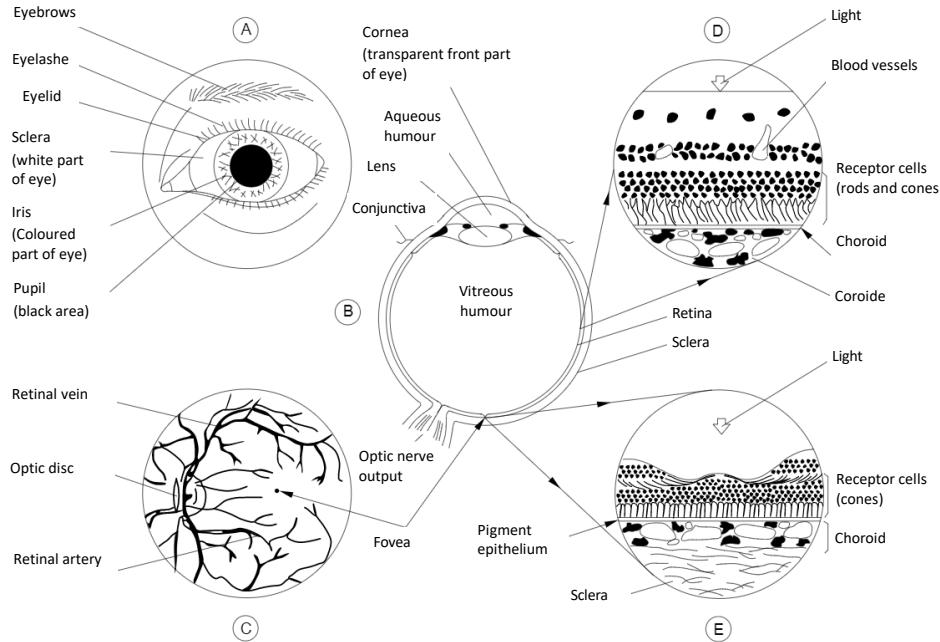

Fig. 4-2 – Physiology of the human eye

Section (A) of Fig. 4-2 displays the external structure of a left eye.

The distance between the eyelids limits the field of vision (FOV) of the eye to an almond-shaped surface. The main elements of the front part of an eye are also indicated.

Section (B) displays the horizontal section of a left eye. The eye is divided into two parts, the anterior or front chamber limited by the cornea, iris and lens, and the posterior chamber limited by the retina, which contains the gelatinous-looking vitreous humor.

Section (C) displays the inside of an intact eye as observed through an ophthalmoscope. This tool directs a light beam through the pupil and illuminates the inside of the eye, thus allowing for its observation. The image seen in this way is called back of the eye. It appears reddish in color, but the main retinal vessels are clearly distinguishable. The other main elements are the optic disc, whitish in color, and the fovea. The fovea is a small depression of the retinal surface which may be more pigmented than the surrounding retina and is the most distinguished area of vision. The fovea is the center of the macula; the macula is responsible for sharp vision.

Section (D) displays the structure of the retina as seen in the section of its surface shown in Fig. 4-2 (B), but enlarged a few hundred times from its natural size. The retina consists of a series of nervous cell layers which cover the photosensitive cells: the cones and rods; in other words, light arriving on the retinal surface must move through the nervous cell layers before reaching the photosensitive cells. Beneath the layer of cones and rods is a layer known as pigment epithelium which contains a black-darkish melanin pigment; under this is a thin layer of blood vessels, the choriocapillaris. The last absorbent layer is the choroid, which contains both pigment cells and blood vessels.

Section (E) displays the structure of the fovea region, enlarged a few hundred times from its natural size. This area only features cones. The nervous cells are located radially towards the external part of this area of sharper vision. The macular pigment, which mainly absorbs wavelengths between 400 nm and 500 nm, is located in Henle's fiber layer.



### 4.5.3 Pathological effects of laser radiation

#### 4.5.3.1 Hazards to the eyes

Fig. 4-2 features a brief description of the anatomy of the eye. The eye is particularly well-suited to receiving and transmitting optical radiation.

Associated pathologies due to excessive exposures are summarized in Tab. 4-2, below. Lasers emitting radiation in the ultraviolet and far infrared represent a hazard for the cornea, while radiation from systems emitting at wavelengths in the visible and near infrared is transmitted to the retina.

<i>Spectral region<sup>3</sup></i>	<i>Pathological effects on the eyes</i>	<i>Pathological effects on the skin</i>
Ultraviolet C (180 nm to 280 nm)	Photokeratitis.	<ul style="list-style-type: none"> <li>Erythema (sunburn);</li> <li>Acceleration of skin ageing process;</li> <li>Increased pigmentation.</li> </ul>
Ultraviolet B (280 nm to 315 nm)		
Ultraviolet A (315 nm to 400 nm)	Photochemical cataract.	<ul style="list-style-type: none"> <li>Darkening of pigment;</li> <li>Photosensitive reactions;</li> <li>Burnt skin.</li> </ul>
Visible (400nm to 780 nm)	Photochemical and thermal lesion to the Retina.	
Infrared A (780 nm to 1 400 nm)	Cataract, burnt retina.	Burnt skin.
Infrared B (1,4µm to 3,0 µm)	Inflammation of aqueous humor, cataract, burnt cornea.	
Infrared C (3,0µm to 1 mm)	Burnt cornea.	

Tab. 4-2 – Pathological effects of lasers in relation to spectral region

Lasers visible in the near infrared represent a special danger for the eye, specifically because the necessary properties for the eye to be an effective light transducer subject highly pigmented tissues to high radiant exposure.

Lasers outside the specter of visible light are particularly hazardous as there is no optical perception of the beam and the protection deriving from palpebral reflexes is absent.

#### 4.5.3.2 Hazards to the skin

In general, skin can withstand a much higher exposure to the energy of a laser beam than the eye.

The biological effect of skin irradiation with lasers operating in the spectral regions of the visible (from 400 nm to 700 nm) and of the infrared (greater than 700 nm) can **vary from a slight erythema to large blisters**.

Ash-colored carbonization is prevalent in tissues with high superficial absorption levels following exposure to short pulsed lasers with high peak power. This may not be followed by an erythema.

Pigmentation, ulceration, the appearance of skin scars and damage to underlying organs may be caused by extremely high irradiation. It has been established that latent or cumulative effects of laser radiation are not frequent.

However, some limited studies have suggested that, in particular conditions, repeated local exposures may sensitize small areas of human tissue, causing changes to the levels of exposure behind minimal reactions and a worsening of tissue reactions to low levels of exposure.

Studies concerning biological thresholds indicate that, with wavelengths between 1500 nm and 2600 nm, the risk of skin lesions follows a similar pattern to that of the eye. The EMP increases within this spectral region for exposures with a duration of up to 10s.

<sup>3</sup> Spectral regions defined by the CIE are only synthetic annotations used to describe biological effects, and may not correspond exactly to the spectral intervals indicated in the CEI EN 60825-1 standard.

#### 4.6 Classification and specific hazards of radiation emitted by TAUWELD 200J

Based on the CEI EN 60825-1: 2014 standard, TAUWELD 200J is classified as indicated in the following Tab. 4-3:

Parameter	Value
Laser class	<b>LASER Class 4</b>
Wavelength	<b>1064 nm</b>
Type of emission	<b>Pulsed, non-repetitive, non-continued</b>
Pulse duration	<i>TAUWELD 200J:</i> <b>From 0,1 to 20 ms</b>
Divergence of the laser beam (in the output window located on the optical channel)	<b>Between 0,5 and 30 Hz</b>
Laser class	<b>7,153°</b>
Maximum emitted power or energy	<i>TAUWELD 200J:</i> <b>10 kW / 200 J</b>

Tab. 4-3 –TAUWELD 200J classification according to CEI EN 60825-1:2014



**WARNING!:** Class 4 lasers are laser products in relation to which direct viewing of the beam and skin exposure are hazardous and in which the viewing of diffuse reflections can also be dangerous. These lasers often also represent a fire hazard.

**This laser emits a radiation in the non-visible specter and is therefore particularly dangerous, as it is not perceivable by the human eye.**

**Furthermore, non-visible laser radiation decreases the (natural) protective effect of palpebral reflexes<sup>4</sup>.**

- D.N.R.O <sup>5</sup> for direct or specularly reflected radiation: 15 m;
- D.N.R.O for diffuse radiation: 0,5 m.



**WARNING!:** Only the use of personal protective equipment can protect the operator from the effects of laser radiation.

**OBLIGATION:** The Employer must mandatorily assess the risks deriving from exposure and choose to make adequate personal protective equipment available to the workers.

<sup>4</sup> The eyelid closes due to the reflected effect of glare.

<sup>5</sup> Nominal Optical Risk Distance.

#### 4.7 Graphic signs and written warnings

Please find below the graphic signs and written warnings located on the machine. These signs were inserted to make the operator aware of hazards or residual potential sources of danger. An explanatory comment can be found next to each exclusively graphic sign. **Make sure you learn the meaning of these signs.**

For information on the position of these signs, please refer to paragraph 4.7.4.



**WARNING!** Failure to understand or pay attention to the meaning of signs and warnings can cause personal injuries, death and/or damage to the machinery or to equipment.

##### 4.7.1 Hazard graphic signs and written warnings

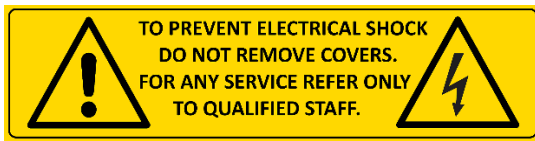

Fig. 4-3 – Hazard pictogram

This sign (featuring indications of the correspondent voltage value) highlights the **hazard** (residual risk) due to the presence of voltage.



Fig. 4-4 – Hazard pictogram

This sign highlights the **hazard** (residual risk) associated with exposure of the eyes and skin to direct or diffuse radiation.

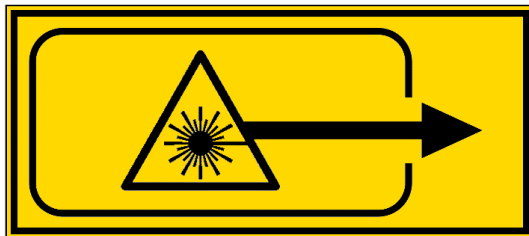

Fig. 4-5 – Hazard pictogram

This sign highlights the **hazard** (residual risk) associated with laser radiation in proximity to an opening (in the welding chamber).

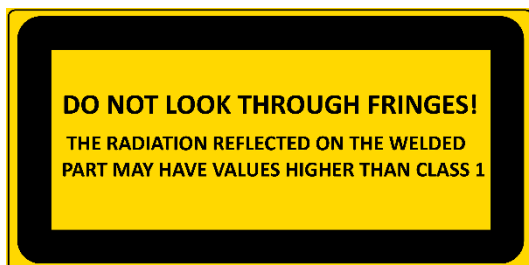

Fig. 4-6 – Explanatory label

This sign highlights the **hazard** (residual risk) associated with laser radiation reflected through the blind.

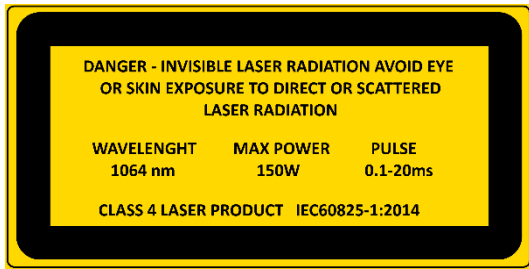

Fig. 4-7 – Warning label

This sign highlights the **hazard** (residual risk) associated with exposure of the eyes and skin to direct or diffuse radiation, and furthermore provides information on the characteristics of the laser source.

#### 4.7.2 Obligation graphic signs and written warnings



Fig. 4-8 – Obligation pictogram

This sign highlights that the operator has an **obligation** to read and understand the manual before using the machine.

Failure to observe instructions can cause death or serious injuries.

#### 4.7.3 Other graphic signs and written warnings

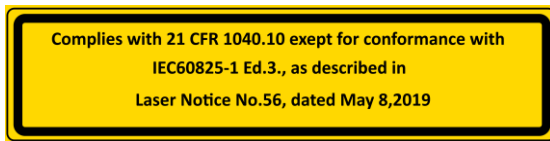

Fig. 4-9 – Conformity pictogram

This sign highlights the manufacturers' conformity to FDA<sup>6</sup> performance standards for laser products.

<sup>6</sup> Food and Drug Administration.

**4.7.4 Position of graphic signs and written warnings**

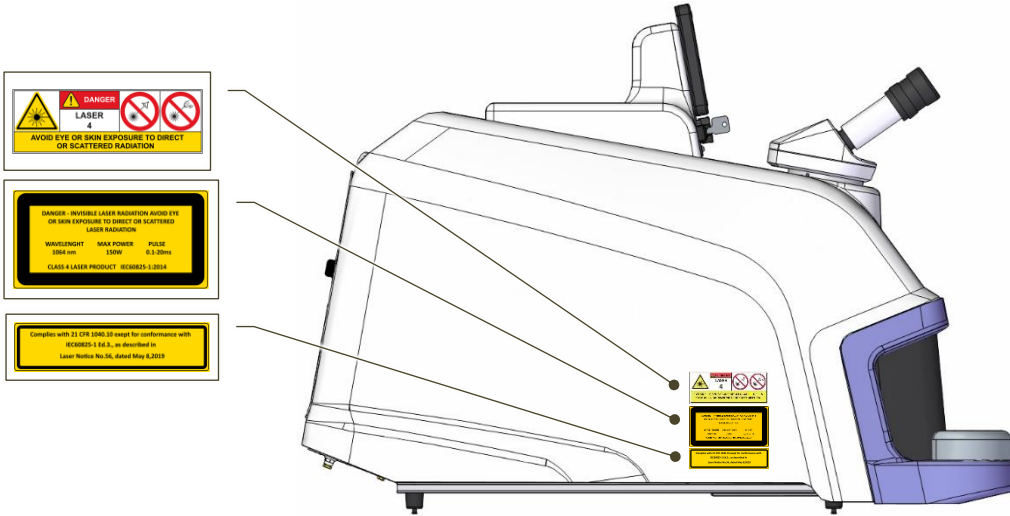

Fig. 4-10 - Position of graphic signs and written warnings – left side view



Fig. 4-11 - Position of CE plate, graphic signs – rear side view

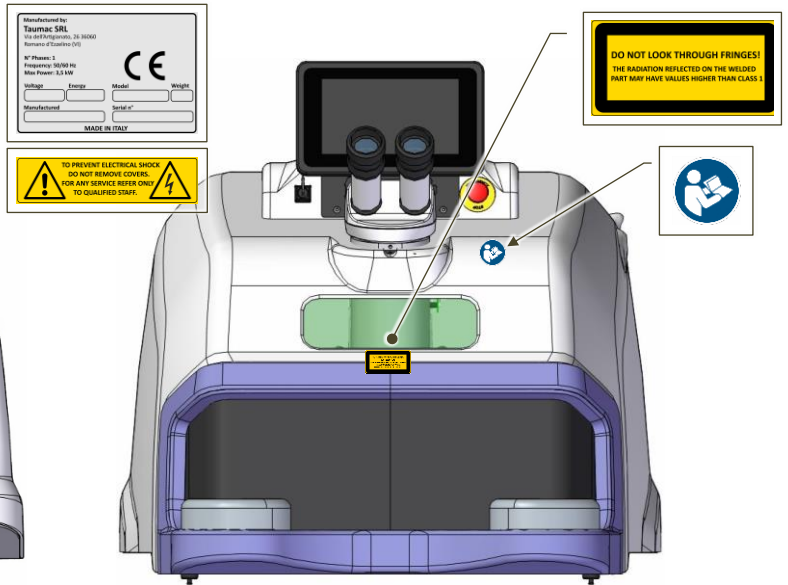

Fig. 4-12 - Position of graphic signs and written warnings – right side view

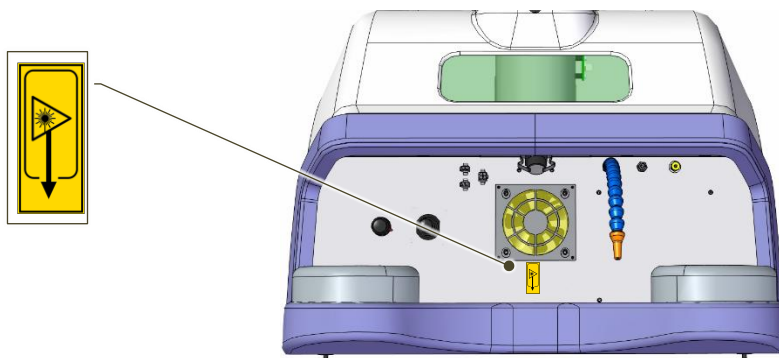

Fig. 4-13 - Position of graphic signs – internal view of welding chamber

#### 4.8 Physical and intellectual requirements of personnel

The personnel must be capable – also on a physical level – of performing necessary operations and of familiarizing with instructions and safety laws. This staff will have been trained (according to performed/assigned tasks) to be able to safely use the machine and/or to perform maintenance operations on the machinery in safe conditions.



**WARNING!:** Failure to understand or pay attention to the meaning of signs and warnings can cause personal injuries, death and/or damage to the machinery or to equipment.



**PROHIBITION!:** Staff members cannot operate on the machine if they have taken substances that reduce reaction times.

The staff can be divided into:

- Personnel in charge of transporting;
- Staff in charge of extraordinary maintenance (support service);
- Laser safety officer;
- Staff in charge of operating the machine.

Each of these profiles is characterized by specific skills described below.

#### 4.9 Personnel in charge of transporting the machine

The personnel in charge of transporting the machine must consist of workers in possession of the necessary professional qualifications to operate with specific work equipment, such as lifting machinery and devices, for example.

Operations requiring the simultaneous intervention of multiple workers must always be coordinated by a supervisor.

The supervisor must assess the potential risk of interference with operations performed by other workers in the location where the machinery is to be installed.

#### **4.10 Staff in charge of extraordinary maintenance (support service)**

In terms of maintenance staff, standard EN 15628 (Maintenance – Qualification of maintenance personnel) identifies the following three professional figures and defines their correspondent necessary skills:

- Maintenance manager (indicatively referable to EQF levels 6 and 7<sup>7</sup>);
- Maintenance supervisor and maintenance engineer (indicatively referable to EQF levels 5 and 6);
- Specialist maintenance technician (indicatively referable to EQF levels 4 or 5).

The skills of the **specialist maintenance technician** consist of the capacity to carry out autonomous maintenance activities, including the following key skills:

- Perform or ensure safe performance of maintenance plans in observance of company strategies;
- Promptly intervene in the event of any malfunctions or anomalies, ensuring effectiveness of recovery operations;
- Observe or ensure full observance of laws and procedures concerning health and safety, as well as protection of the environment;
- Ensure availability of materials, equipment and tools needed for performing maintenance operations;
- Coordinate and/or supervise maintenance operations;
- Ensure quality standards of maintenance operations;
- Use and ensure use of ICT (information and communication technology) systems.



***OBLIGATION! Extraordinary maintenance operations (support service) can be performed exclusively by personnel of Taumac S.r.l. or by dealers / installation technicians authorized by Taumac S.r.l.***

<sup>7</sup> EQF is the European Qualifications Framework, a Standard reference list of job qualifications that implements a system based on learning results obtained at the end of a training process. Learning results are defined in terms of Knowledge, Skills and Responsibility/Autonomy. The overall result is an index, included between 1 and 8, which aims to promptly and univocally identify the learning level achieved in a specific context.

#### 4.11 Laser safety officer

In many countries, in case of class 3B or 4 laser products, the employer must appoint a LASER SAFETY OFFICER. Consult local laws in this regard.

#### 4.12 Staff in charge of operating the machine

The machine must be run by a **professional** operator, as described under paragraph 5.4, which also describes his/her position and tasks.

The operator must never perform different tasks on the machine than those described for its operation, with the exception of those described under paragraphs 9.2 (ordinary maintenance) and 9.5 (cleaning the machine); all extraordinary maintenance operations, repairs or other actions different than those required for operation of the machine are reserved to qualified staff.



**PROHIBITION!: Never take the personal initiative of intervening to solve machine downtime situations unless strictly linked to operating the machinery.**

**Absolutely do not try to help staff in charge of maintenance or tooling operations.**

#### 4.13 Training of staff

The machine can be used exclusively by trained staff that has passed the training period set during the sale contract phase and is therefore authorized to use the machinery. In any case, the machine cannot be used by personnel that is not adequately trained with regards to its operation and safety devices.



**WARNING!: Taumac S.r.l. declines any liability deriving from incorrect operations performed by staff not trained to use the machinery, and from failure to observe general laws on work safety.**

#### 4.14 Incorrect use

The machine is designed to be used exclusively for the purposes described in the specific section of this manual (paragraph 5.3). Different forms of use than those described in this manual are to be considered incorrect and therefore not compliant with safety laws.



**WARNING!: Improper use of the machine can cause personal injuries, death and/or damage to the machine or to equipment. In particular, it can lead to harmful exposure to laser radiation.**

Please find below a series of possible incorrect forms of use which can cause personal injuries or damage to the machine or to equipment, for which Taumac S.r.l. refuses to respond and rejects any liability:

- Unauthorized modifications or replacements of parts of the machine;
- Failure to observe safety instructions;
- Failure to observe instructions concerning the installation, use, functioning, maintenance, repairs of the machine or performance of any of the above by unqualified staff;
- Use of incorrect or incompatible materials or of auxiliary equipment;

Failure to observe rules or currently effective laws concerning safety in the workplace.



## 5 Characteristics and technical data

### 5.1 Description of the machine

TAUWELD 200J (Fig. 5-1 and Fig. 5-2) is a welding machine for artefacts made of metallic materials that uses electromagnetic laser radiation as an energy source for heating metals to melting temperature.

The machine consists of the following elements:

- Machine body;
- Stereomicroscope vision system binocular;
- Welding chamber;
- Control device

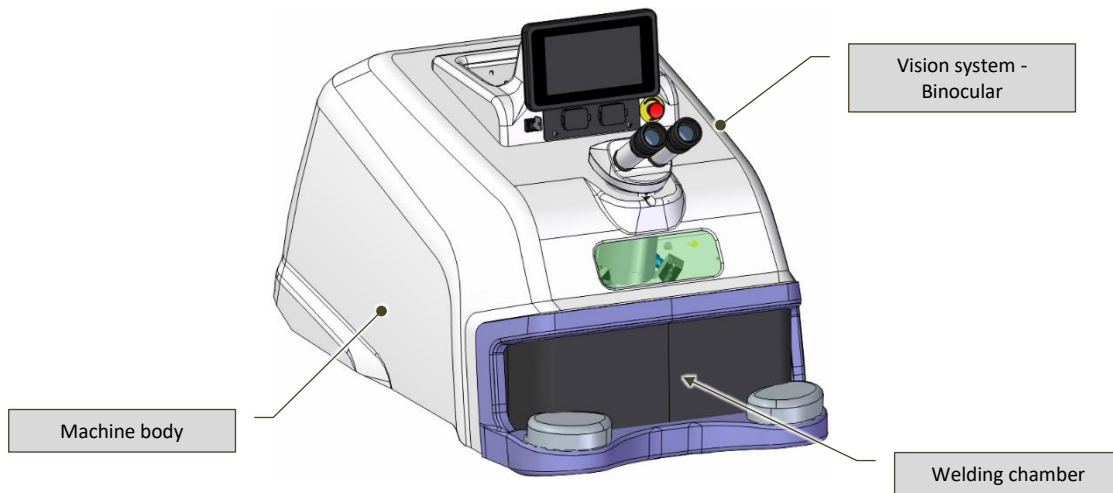

Fig. 5-1 – TAUWELD 200J (top view)

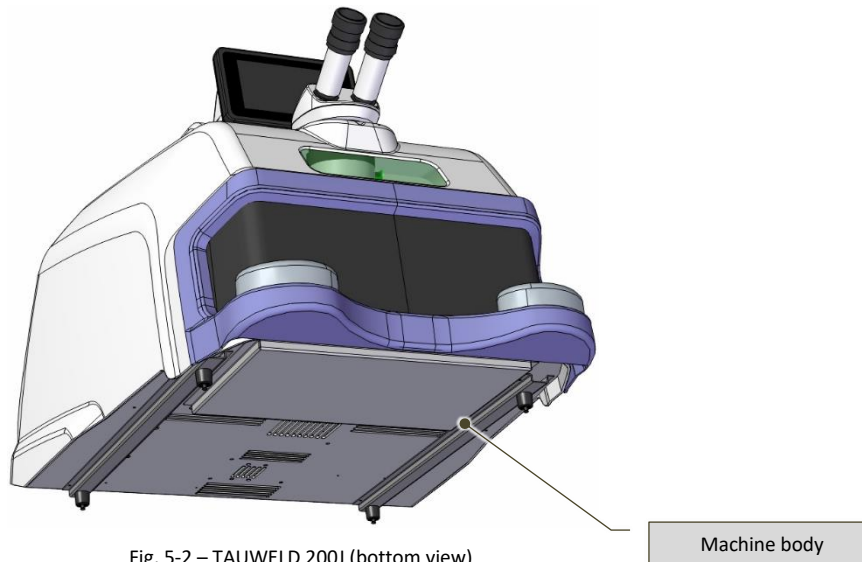

Fig. 5-2 – TAUWELD 200J (bottom view)

### 5.2 Applicable technical regulations and laws

The machine was designed in observance of the following Community rules on the safety of the machinery and laser system products:

- EN ISO 12100:2010 Safety of machinery - General principles for design - Risk assessment and risk reduction;
- EN 60204-1:2018 Safety of machinery - Electrical equipment of machines – Part 1: General requirements;
- CEI 76-11:2011 Safety of laser products - Part 14: User guide (IEC TR 60825-14:2004);

- EN 60825-1:2014 Safety of laser products - Part 1: Equipment classification and requirements;
- EN 61000-6-2:2005/AC:2005 Electromagnetic compatibility (EMC) - Part 6-2: Generic standards Immunity for industrial environments;
- EN 61000-6-4:2007/A1:2011 Electromagnetic compatibility (EMC) - Parte 6-4: Generic standards - Emissions for industrial environments;
- EN 61000-3-2:2014 Electromagnetic compatibility (EMC) - Part 3-2: Limits - Limits for harmonic current emissions (equipment input current  $\leq 16$  A per phase);
- EN 61000-3-3:2013 Electromagnetic compatibility (EMC) - Part 3-3: Limits - Limitation of voltage changes, voltage fluctuations and flicker in public low-voltage supply systems, for equipment with rated current  $\leq 16$  A per phase and not subject to conditional connection.

Furthermore, the following European Community directives were also observed:

- European Parliament and Council Directive 2006/42/CE dated May 17<sup>th</sup> 2006 on machinery, modifying Directive 95/16/CE (recasting);
- European Parliament and Council Directive 2014/30/UE dated February 26<sup>th</sup> 2014 and concerning the harmonization of member State legislations on electromagnetic compatibility (recast);
- European Parliament and Council Directive 2014/35/UE February 26<sup>th</sup> 2014 and concerning the harmonization of member State legislations on making available on the market electrical material for use within specific voltage limits.
- European Parliament and Council Directive 2011/65/UE dated June 8<sup>th</sup> 2011 on the restriction of use of specific hazardous substances in electric and electronic equipment;
- Delegated directive (UE) 2015/863 dated March 31<sup>st</sup> 2015 modifying annex II of European Parliament and Council Directive 2011/65/UE with regards to the list of substances characterized by restrictions of use.



***INFORMATION!*** Even if the machine is compliant with applicable EU Directives, we cannot exclude that these may be (or have been) implemented via specific legislation at a local (national) level.

### 5.3 Intended conditions of use

TAUWELD 200J was designed exclusively to perform operations described under paragraph 5.1 of this manual.

The machine must operate in environmental conditions that comply with the descriptions featured in the specific section (Permissible environmental values) of Tab. 5-3.

In terms of typology and dimensions, the product on which the machine operates must comply with requirements listed in the paragraph on characteristics of the product (5.6).



## 5.4 Residual risks

The machine requires the preparation of work stations as indicated in the following Tab. 5-1:



<b>Work station</b>	<b>N° of operators</b>	<b>Operations</b>
In front of the machine	1 operator	Welding

Tab. 5-1 – Work stations

In normal work conditions, the residual risks described below (Tab. 5-2) may still be present:

<b>Parameter</b>	<b>Risks</b>	<b>P.P.E. *</b>
Transportation and handling	<b>Risk of impact and crushing:</b> due to incorrect use of lifting and transportation tools, or during manual transportation of the machine (if the machine is dropped by accident).	
Installation, assembly and connections	<b>Risk of impact and crushing:</b> due to incorrect use of lifting and transportation tools, or during manual transportation of the machine (if the machine is dropped by accident). <b>Risk of impact, tripping and falling:</b> if the area where the machine is installed is not sufficiently illuminated. <b>Risk of electrocution and electric shock:</b> if the machine is connected to a non-suitable/damaged electrical system or if the device was damaged during transportation or assembly.	
Loading and unloading of the product	<b>Risk of muscular-skeletal injuries:</b> if the operator lifts heavy materials incorrectly (or by himself/herself) (please also refer to paragraph 6.3). <b>Risk of electrocution and electric shock:</b> if the machine is connected to a non-suitable/damaged electrical system or if the device or the cable connecting it to the electrical power supply network are damaged, modified or altered.	 
Regulations and use	<b>Risk of exposure to laser radiation:</b> direct viewing of the laser beam and exposure of the skin are hazardous and the viewing of diffuse radiation can also be dangerous. These lasers are often associated with a danger of <b>fire</b> , as they may trigger the combustion of flammable substances, such as volatile substances, as well as methacrylate or plastic resins. <b>Risk of anoxia:</b> if the inerting gas (which does not represent a health hazard in itself) dangerously reduces the concentration of oxygen in the air due to inadequate natural ventilation. Do not cover the ventilation grids. Read the safety data sheets of the substances in use. <b>Residual risk due to the formation of smoke and steam during welding operations:</b> The interaction of the laser beam with organic and inorganic materials causes the formation of smoke and steam which, in some cases, can be harmful to human health and/or toxic. Therefore, the machine must be placed on a vacuumed surface or the smoke must be extracted with a suction system (not supplied with the machine). <b>Residual risks deriving from the presence of persons</b> unrelated to operations near the machine. <b>Risk of impact, tripping and falling:</b> if the area where the system is installed is not sufficiently illuminated.	

**Laser Welding machine - TAUWELD 200J**

<i>Parameter</i>	<i>Risks</i>	<i>P.P.E. *</i>
Maintenance	<p><b>Risk of electrocution and electric shock:</b> the machine is powered by electricity, and therefore operations on live or disconnected electrical parts must be performed exclusively by the specifically responsible technician, in observance of all necessary precautions (EN 50110-1). Removal of the case, parts of the case or guards is reserved exclusively to Taumac S.r.l. .</p>	
	<p><b>Risk of exposure to laser radiation:</b> direct viewing of the laser beam and exposure of the skin are hazardous and the viewing of diffuse radiation can also be dangerous. Perform maintenance operations only when the machine is disconnected from the electrical network. Removal of the case, parts of the case or guards is reserved exclusively to Taumac S.r.l. .</p>	 
<p>* Based on the specific operations to be performed, the employer must assess the adequacy of the P.P.E. in relation to the residual risk linked to use of the machine, also in relation to the presence of further risks during operations.</p>		

Tab. 5-2 – Residual risks

The risks listed above are reduced to acceptable levels if the personnel operates in adequate conditions, as described at the beginning of this paragraph.

## 5.5 Technical data of the machine

### 5.5.1 Technical data

Parameter		Description	TAUWELD 200J
Dimensions		Minimum length of installation area	<b>2600 mm</b>
		Minimum width of installation area	<b>2900 mm</b>
		Minimum height of installation area	<b>2700 mm</b>
		Maximum length of machine	<b>715 mm</b>
		Maximum width of machine	<b>Approx. 552 mm</b>
		Maximum height of machine	<b>516 mm</b>
Connections		Electricity	
Masses		Compressed Air	
		Inerting gas	
Masse		Overall weight of machine and packaging	<b>56 Kg</b>
Power supply		Net weight of machine (without coolant)	<b>43 Kg</b>
Power supply	Electricity	Supply voltage for electrical equipment	<b>230 VAC (opt. 110 VAC) +/- 5%</b>
		Supply frequency	<b>50/60 Hz</b>
		Type of connection to ground circuit (IEC 60364-3) <i>Different electric distribution systems must first be checked and approved by the manufacturer.</i>	<b>TN-S</b>
		Supply voltage for auxiliary circuits	<b>24 V CC +/- 10%</b>
		Medium power consumption	<b>2,5 kW</b>
		Shielding gas	Type of gas
		Purity level	<b>99,8 %</b>
		Maximum operating pressure	<b>1,5 bar</b>
		Consumption (at maximum pressure level)	<b>2,4 l/min</b>
Laser characteristics		Class	<b>LASER Class 4</b>
		Wavelength	<b>1064 nm</b>
		Type of emission	<b>Pulsed, non-repetitive, non-continued</b>
		Repetition rate	<b>0,5 ÷ 30 Hz</b>
		Shot duration	<b>0,1 ÷ 20 ms</b>
		Divergence of the laser beam (in the output window located on the optical channel)	<b>7,153°</b>
		Maximum emitted power or energy	<b>10 kW / 200 J</b>
		Average power	<b>150 W</b>

**Laser Welding machine - TAUWELD 200J**

<b>Parameter</b>	<b>Description</b>	<b>TAUWELD 200J</b>
	Duty Cycle	<b>80 %</b>
	Size of laser beam diameter	<b>0,2 ÷ 2,0 mm</b>
	Type of cooling system	<b>Liquid</b>
	Cooling tank capacity	<b>2 liters</b>
	LASER crystal type	<b>Nd: YAG</b>
Permissible environmental values	Operating temperature	<b>+5 °C ÷ +40 °C<sup>8</sup></b>
	Storage temperature	<b>-20 °C ÷ +55 °C</b>
	Environmental temperature variations	<b>Max. 1.1°C / Min</b>
	Average temperature	<b>Not above +35°C in 24 h</b>
	Relative humidity (RH) range	<b>65 % or less</b>
	Vibrations	<b>≤ 0,5 G</b>
	Altitude	<b>Up to 1000 m.a.s.l.</b>

Tab. 5-3 – Technical data

**5.5.2 Noise levels**

The machine was designed to reduce noise emissions at their source. In normal conditions of use, the sound power level of the machine is:

<b>Acoustic pressure</b>	
(A)-weighted equivalent continuous acoustic pressure	<b>&lt; 70 dB</b>
Weighted instantaneous acoustic pressure	<b>&lt; 130 dB</b>

Tab. 5-4 – Acoustic pressure

The noise levels indicated above are emission levels measured in normal conditions of use in observance of the EN ISO 3744, 3745, 3746 and 11200-11204 standards. These values may vary if any modifications are made to the machine, and will therefore need to be re-determined in relation to such changes.

The noise levels indicated above are emission levels and do not necessarily represent safe operating levels.

Despite the existence of a relation between emission levels and exposure levels, this cannot be used in any reliable way to establish if further precautions are necessary or not. The factors that determine the level of exposure workers are subjected to include duration of the exposure, environmental characteristics of the workplace and the presence of other sources of noise (number of machines, adjacent processes, etc.). Furthermore, even permissible exposure levels may vary from country to country. In any case, this information will help the user to assess the danger and risk he/she is exposed to.

<sup>8</sup> Electrical equipment is capable of functioning correctly when relative humidity does not exceed 50% at a maximum temperature of +40 °C. Higher relative humidity levels can be permissible at lower temperatures (e.g. 90% at +20 °C).



**WARNING!** *The acoustic impact produced by the machine in the surrounding environment can be considered of little relevance in test conditions.*

*In any case, it is important to keep in mind that the level of exposure of the operator in charge of running the machine will have to be assessed in the actual operating conditions of the machine, in conformity with current legislation (of the country where the machine is placed on the market).*

Pursuant to Community Directive 2003/10/CE, given that in test conditions the acoustic pressure of the machine does not cause a worker located appropriately and continuously in the installation area to be exposed to pressure equal or above 80 dB (A) on a daily basis, the manufacturer is not required to provide information concerning the noise levels of the machine.

### 5.5.3 Vibrations

The vibration levels produced by the machine are very low, and do not represent a hazard for the operator.

In any case, the levels were determined in compliance with the ISO 5349 standard for vibrations transmitted to the hand/arm system (HAV).

#### Vibrations

Vibrations transmitted to hand/arm system	$\leq 2,5 \text{ m/s}^2$
---	--------------------------

Tab. 5-5 – Vibrations



**OBLIGATION!** *No specific measures are required to protect the operator from the effects of vibrations produced by the machine. The operator must immediately stop the machine in the presence of any abnormal vibrations and notify the maintenance staff of the issue.*

### 5.5.4 Levels of protection

#### Protection level of electrical equipment (IP<sup>9</sup>)

Protection level against solid foreign objects (dust-tight)	<b>2</b>
Protection level against water (water-tight)	<b>X</b>
Protection level against access to dangerous parts	<b>B</b>

Tab. 5-6 – Levels of protection

<sup>9</sup> As set by CEI EN 60529.

**5.6 Product characteristics**

**5.6.1 Technical characteristics of workable products**

The products to be processed (an example is shown in Fig. 5-3) consist of products for the goldsmith/jewelry sector, such as, for example: jewels and glasses, watches and bracelets.



Fig. 5-3 – Examples of products to be processed for the goldsmith sector

To be workable with TAUWELD 200J products must be made exclusively with the materials listed in the following Tab. 5-7.

<i>Technical characteristics of workable products</i>		
Dimensions	Maximum size of the product (L x W x H)	<b>400x150x110 mm</b>
Materials		<b>Titanium</b>
		<b>Yellow gold</b>
		<b>Rose gold</b>
		<b>White gold</b>
		<b>Platinum</b>
		<b>Steel</b>
		<b>Palladium</b>
		<b>Nickel silver</b>
		<i>Only for Series PLUS</i>

Tab. 5-7 – Permissible materials



**PROHIBITION!:** Use of the welding machine to weld different materials than those indicated in the “Usable materials” table above IS STRICTLY PROHIBITED. If you need to weld different materials, we invite you to contact the manufacturer. Do not attempt to weld different materials than those indicated above, in any way.  
It is forbidden to weld flammable materials.





**WARNING!** *Make sure that the metals to be processed feature no impurities which may cause the formation of smoke or gas during the melting stages.*

### **5.6.2 Weld materials**

If required by the type of welding in question, the operator can use weld materials such as silver, monel, steel, cobalt-chromium alloy and titanium.

## 6 Transport and installation

### 6.1 Transport

The machine and all the provided parts are usually supplied fully packaged in a cardboard box. During transportation, the box is fastened to a transport pallet; in the case of transportation via airplane, the box is in turn packaged within a wooden crate.

The pallet for transportation of the machine must be lifted and handled by using a forklift with suitable capacity. The capacity of the forklift must correspond to at least the weight of the packaged machine, increased by 20%.



#### **INFORMATION!**

- *Conserve the box for future storage, transportation and/or sale;*
- *Unnecessary packaging materials must be disposed of based on their typology and in compliance with currently effective laws concerning waste management.*

### 6.2 Handling and removal of packaging



#### **WARNING!: Observe the following instructions.**

Once removed from its packaging, TAUWELD 200J, can be lifted and/or handled manually **by two people**:

- By observing safety conditions described under paragraph 6.3;
- By gripping with both hands positioned on the two lower edges;
- By making sure:
  - You don't knock and drop the machine, in order to avoid damage to its electrical parts and internal optical components,
  - You don't tilt or flip the machine or the package.

Take the machine, still within its packaging, to the installation site and, after opening the box:

- Extract the power supply cable, the control pedal, the tube and the cooling liquid top-up funnel from the upper part;
- Extract TAUWELD 200J from its box and place it on a work surface (please also refer to paragraph 6.6);
- Remove the protective film from the machine and its protruding parts.

Now, the machine can be installed for use.

If the machine is not used for long periods of time, it may be stored in its box, after emptying the cooling liquid tank (please refer to paragraph 0), and by performing all installation and unpacking operations in reverse order.

### 6.3 Manual handling of loads

Manual handling of loads (MHL) must be carried out in safe conditions to avoid overloading the dorsal-lumbar tract of the spine. Please find below a series of safety instructions concerning manual handling of loads.



**WARNING!:** Lifting and handling operations must be performed in compliance with maximum weight liftable by a person<sup>10</sup>; use specific lifting devices to avoid the risk of any back injuries.



**PROHIBITION!:** Do not manually lift products that exceed the permissible limit!

In any case, it is important to remember that during manual handling activities, operators are subject to the following risks:

- Falling of loads;
- Crushing of feet.

To prevent risks deriving from incorrect handling of loads, please observe the following general indications:

- Make sure the floor is stable and smooth;
- If possible, use suitable transportation devices (e.g. hand pallet trucks Fig. 6-1, forklifts or cranes);



Fig. 6-1 - Transportation devices

- Hold a stable position;
- Flex your knees (at a 90° angle) and use the muscles in your legs to lift the load. Lift the load slowly, while keeping your back straight (Fig. 6-2);



Fig. 6-2 – Lifting technique

- Avoid torsions of the bust (Fig. 6-3);

<sup>10</sup> 25 kg for men and 15 kg for women, according to the ISO 11228-1 standard (also check the limits set by national laws regarding the health and safety of workers).

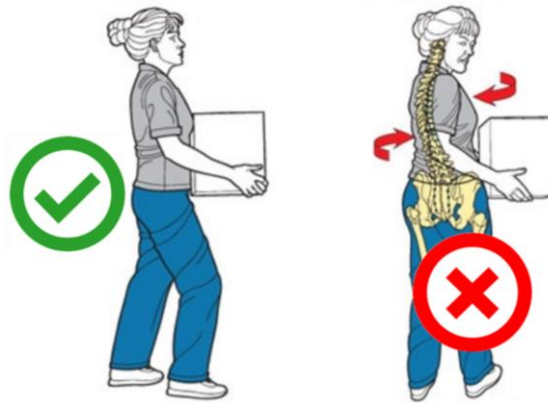

Fig. 6-3 – Handling technique

- Keep the load as close as possible to your body;
- Distribute the load on both sides;
- Keep your view clear;
- Ensure at least two operators manage the lifting of bulky loads (Fig. 6-4);
- Observe the limits concerning maximum weight liftable by one person;
- If the load is too heavy or lifting it requires a noteworthy physical effort, it is advisable to opt for one of the following solutions:
  - Use auxiliary tools,
  - Divide the load into multiple parts that can be transported individually,
  - Transport the load with help from another person.

If certain components need to be moved by pushing or pulling, observe the following general indications:

- Always operate in a stable position;
- If possible, place the load on devices with wheels;
- It is preferable to push by leaning your back against the load and keeping your arms parallel to your body; if you push the load frontally, make sure you keep your back straight;
- Remember it is always preferable to push rather than pull;
- If pulling is required, always use secure gripping points (ones that will not break due to the pulling operation).

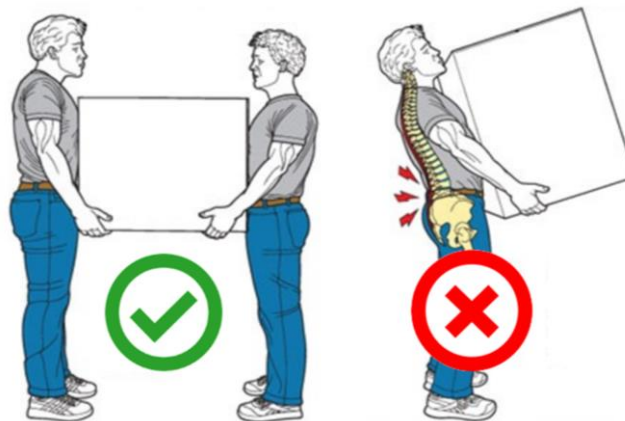

Fig. 6-4 - Handling technique

## 6.4 Installation



**WARNING!** Before proceeding with installation of the machine, carefully read the instructions below.

Failure to observe the following warnings can cause injuries, death or damage to equipment.

Taumac S.r.l. declines any liabilities for damage to persons or things due to installation in an environment characterized by one of the situations described below.

## 6.5 Installation limits



**PROHIBITION!** The machine cannot be installed in explosive atmosphere environments as defined by standards EN 60079-10-1 "Explosive atmospheres. Part 10-1: Classification of places – Explosive atmospheres due to the presence of gas" and EN 60079-10-2 "Explosive atmospheres. Part 10-2: Classification of places – Explosive atmospheres due to the presence of combustible dusts".

Machines, components and devices designed to operate in explosive atmospheres must feature the  (ATEX) label as set forth by standard EN 60079-14 "Explosive atmospheres. Part 14: Design, choice and installation of electrical systems".



**PROHIBITION!** The machine cannot be installed in environments requiring a higher IP protection level than 2X.



**PROHIBITION!** As use of these lasers entails the danger of fires, the machine must not be installed near flammable materials. A fire extinguisher must be kept near the machine.



**WARNING!** Do not perform welding operations in proximity of degreasing, cleaning or vaporization areas. A reaction could take place between the heat and the vapors, generating highly toxic and irritating gases.

## 6.6 Preparation of the installation site

The machine can be installed only in a specially prepared site, located upon a stable work surface, capable of sustaining its weight (please refer to Tab. 5-3), in a perfectly horizontal position and at a height from the floor that ensures ergonomic use by the operator; the work surface must be of suitable dimensions to allow for use of the machine.

**As established by currently effective laws, the installation site must comply with requirements for hosting a class 4 laser (laser controlled area, LCA).**

The site is a well-ventilated indoor area.

The minimum dimensions of the installation area are 2600 x 2900 mm, mm, in order to ensure adequate access to the machine and suitable space for maneuvering around it. The minimum height of the building where the machine is installed must correspond to 2700 mm.

The client is responsible for preparing the power supply network (electricity). This network must be designed and sized to guarantee correct functioning of the machine and compliance with safety laws.

The work environment must feature an independent lighting system and an adequate aspiration system for fumes deriving from machine operations; in terms of the latter, the *ideal* configuration (to obtain a healthy environment and protect the operator's health) is one that features a suction vent (to be connected to an aspiration system via a duct – *these elements are not supplied with the*

machine) located directly on the worktable, under the machine (as schematically illustrated in Fig. 6-5), and corresponding with the product smoke output grid (

Fig. 6-6).

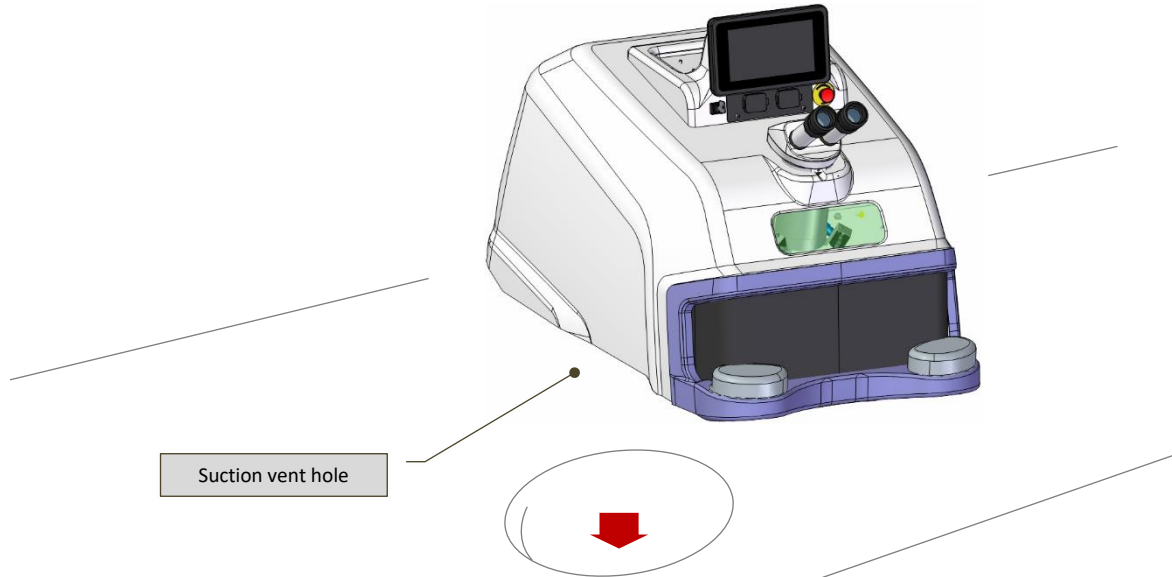

Fig. 6-5 – Ideal installation on worktable



**WARNING!** *Welding operations produce smoke and gas: breathing these can be harmful for human health.*



**OBLIGATION!** *The smoke extraction system (not supplied with the machine) must ensure an adequate aspiration level during all work phases.*

*Minimum suction capacity of this system depends on multiple factors (environmental, related to how frequently the machine is used, and so on).*

*Before being released into the environment, the smoke must be filtered.*

## 6.7 Assembly

The machine is supplied fully assembled.

To install the machine, proceed as follows:

- Place TAUWELD 200J on the work surface (please also refer to paragraph 6.6), so that:
  - It is leaning all four feet (
  - 
  - Fig. 6-6);
  - The welding chamber is positioned outside the work surface, with the lower rear side leaning on the edge of the surface;

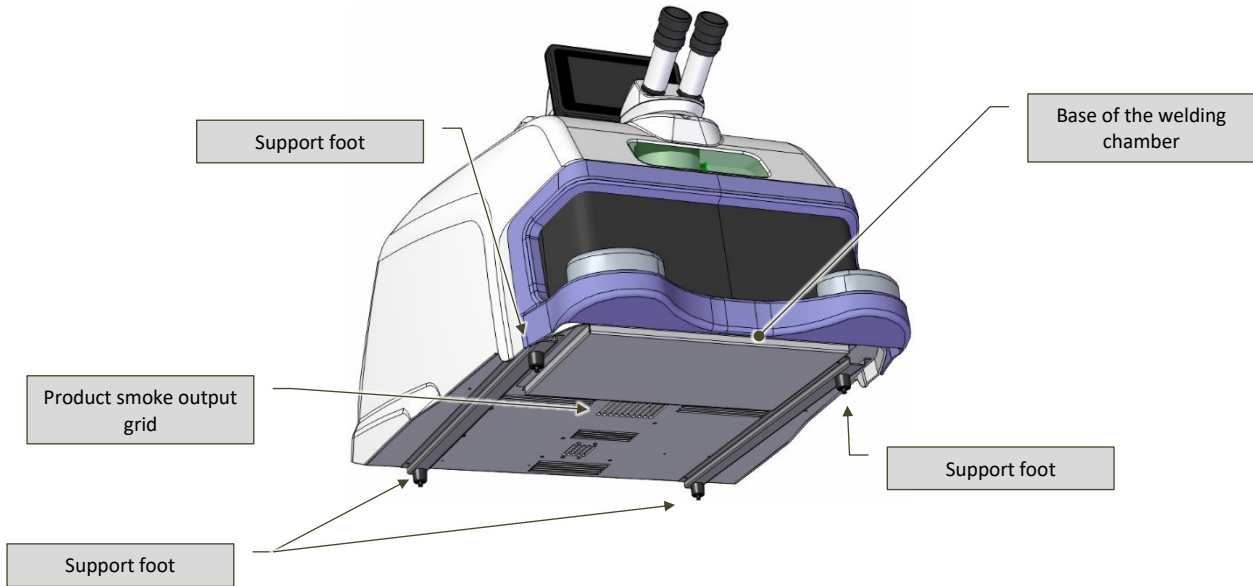

Fig. 6-6 – View of machine support base

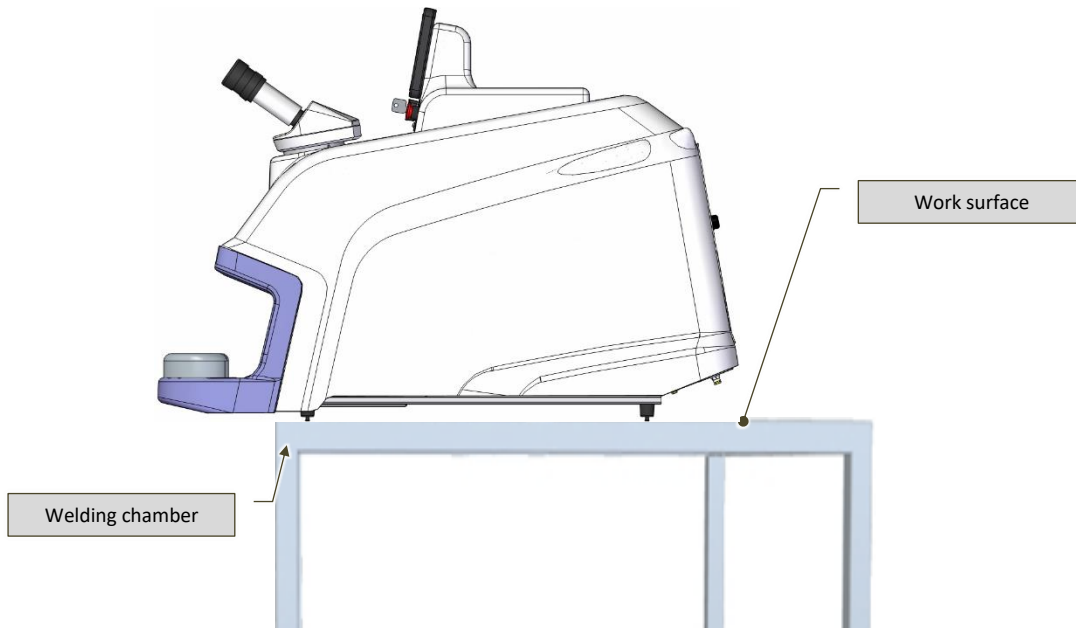

Fig. 6-7 – Positioning on the work surface

- Connect the control pedal of the machine:
  - Connect the male connector of the trigger control pedal to the female DB-9 female serial port (Fig. 6-8), located on the rear of the machine;
  - Place the control pedal on the floor, in front of the machine.



Fig. 6-8 - Position of control pedal connection

- Connect the electrical cable and then the plug it into the power supply network (please refer to paragraph 6.8);
- If required, connect the compressed air supply (please refer to paragraph 6.10);
- If required, connect the shield gas supply (please refer to paragraph 6.10);
- Fill up the cooling circuit tank with cooling liquid (please refer to paragraph 7.3.1).



**PROHIBITION!** *If the machine must be moved, pay attention not to tilt it or flip it over, to avoid cooling liquid leaking into the machine.*

## 6.8 Lighting



**WARNING!** *The installation site must feature sufficient lighting for the performance of use and maintenance operations.*

The optimal lighting level obviously varies according to the type of operations to be performed; please refer to the EN 12464-1 standard (paragraph 5.3) for detailed information concerning the type of activity and the work environment.



## 6.9 Connection to the electrical network

### 6.9.1 Instructions



**WARNING!** The machine must be connected to the grounding system. Grounding continuity must be ensured for all electrical equipment. For this purpose, the client must supply the connection points for the grounding system of the building, making sure the system is compliant with requirements set forth by current legislation.



**OBLIGATION!** Only use the supplied electrical cable to connect the machine to the electrical grid! Do not replace or change the connection plug. If necessary, please contact Taumac S.r.l. .

### 6.9.2 How to connect

Connect the supplied power cable to the power supply connector (Fig. 6-9) located on the rear of the machine.

Insert the Schuko plug of the power cable into the wall socket (Fig. 6-10).

The power supply line the machine is connected to must be protected by a circuit breaker capable of withstanding the correspondent electrical loads.

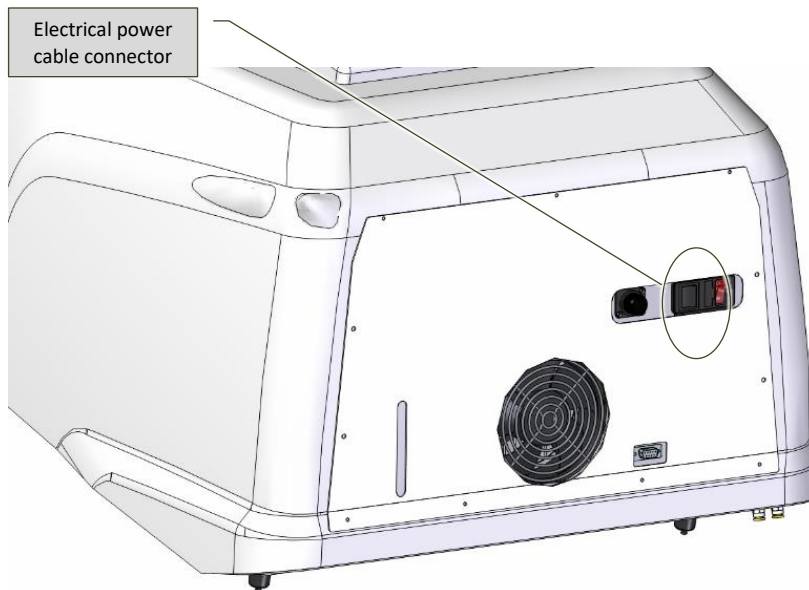

Fig. 6-9 – Electrical power cable connector

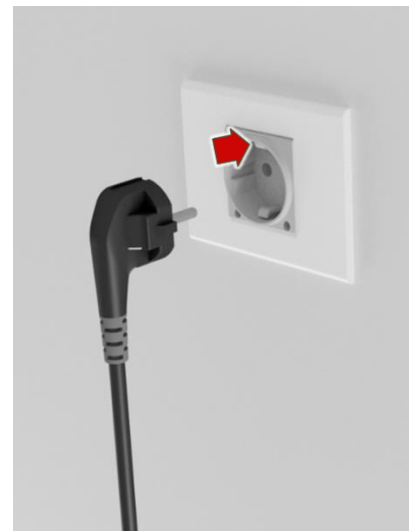

Fig. 6-10 – Socket (Schuko) / 2-pin plug + grounding

### 6.9.3 Protection from electric shocks

#### 6.9.3.1 Direct contact

Direct contact is when “persons or animals come in contact with live parts”, i.e. with dangerous voltage levels (EN 60204-1).

All electrical devices are inserted within specific casings for electrical material, which require a tool to be opened.

Electrical devices which cannot be enclosed in casings for technical reasons must feature suitable isolation systems for the correspondent voltage level and for the environment in which they are used.

#### 6.9.3.2 Indirect contact

Indirect contact is when “persons or animals come in contact with masses<sup>11</sup> that are live due to faulty conditions” (EN 60204-1).

The following method was selected to protect persons from indirect contact:

- Automatic interruption of power supply.

Coordination against indirect contact takes place by checking that, at the time of the fault current from one of the phases of the equipment, the devices used to intercept the fault current (fuses, automatic switches and circuit breakers) open the faulty circuit within time frames that are compatible with the safety of persons, in relation to the electricity distribution system.

In the case of TT distribution systems, the fault current generated in the circuit must correspond to the following relation:

$$R_a * I_a \leq 50 \text{ V}$$

In which:

- **R<sub>a</sub>** = earth resistance;
- **I<sub>a</sub>** = current level that triggers the protection device within time frames set by law;
- **50V** = conventional safe voltage value.

---

<sup>11</sup> Conductive part of a machinery which can be touched and is not live in normal operating conditions, but may become live in faulty conditions (EN 60204-1).

## 6.10 Shield gas/compressed air connection



**OBLIGATION!:** This operation can only be performed by the dealer / authorized installation technician!

TAUWELD 200J can be set up for use with a shield gas (argon), an ideal choice when welding materials such as titanium, to protect the material from oxidation and improve welding quality.

The machine features the following elements (Fig. 6-11):

- An articulated nozzle, for dispensing the gas within the welding chamber.

The rear of the machine features specific quick connections (Fig. 6-12) for the shield gas (for example, via tanks – not supplied with the machine, to be procured by the client / user).

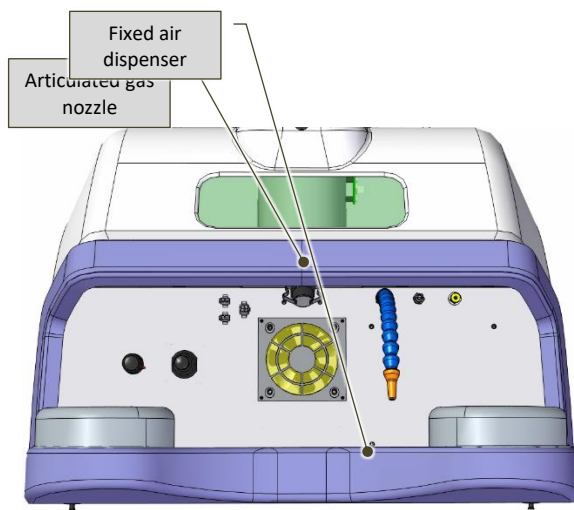

Fig. 6-11 – Air and gas dispensers inside the welding chamber

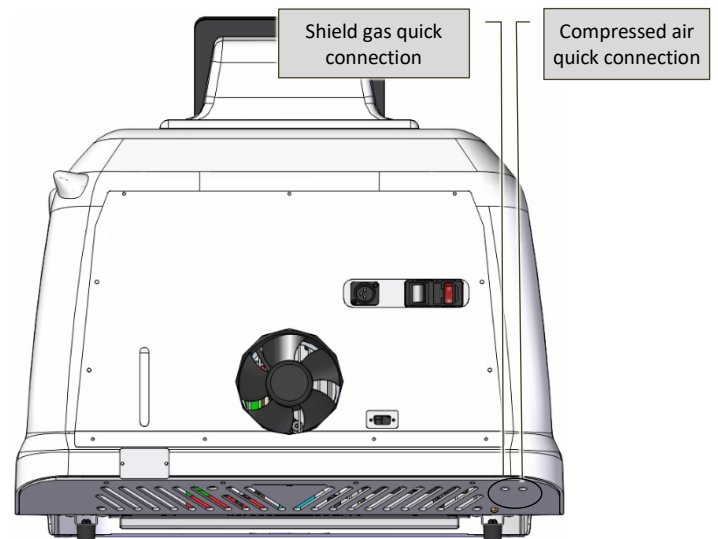

Fig. 6-12 – Quick connections for shield gas and compressed air supplies



**WARNING!:**

- All operations to connect the shield gas and compressed air supplies must be performed in the absence of pressure in the pressurized air circuit;
- The input shield gas must have a maximum pressure of 1,5 bar and a continuous flow rate of 2,4 l/min;
- All tubes connected to the machine must be capable of withstanding operating pressure levels;
- Supply tubes located outside the machine must be subjected to regular checks for wear or damage;
- The supply tubes must never be compressed or crushed. Place these tubes in a position that ensures no operators will tread or trip on them.



**WARNING!:**

- The gas contained in the tanks is pressurized, so the tanks can explode if not handled with care;
- Protect the tank from excessive heat or impact;
- Install the tanks in a vertical position, fastening them to a fixed support with a chain or a specific tank holder to avoid falls or impacts;

## Laser Welding machine - TAUWELD 200J

- *Keep the tanks distant from the welding site and any electrical circuits;*
- *Use only regulation tanks and pressure reducers, tubes and connections that have been approved for this specific use; keep these elements and all connected parts in good conditions;*
- *Do not expose your face to the output valve of the tank when open;*
- *Always keep the valve covered with a screw cap, except when using gas from the tank, i.e. when the tank is connected to the equipment.*



**WARNING!** *Although not a health threat, inserting gas can dangerously lower the concentration of oxygen in the air, and therefore cause anoxia!*

*The employer must assess this hazard and if necessary make sure the workplace features sufficient natural ventilation.*

### 6.11 Further connections

The machine features further connection points, such as:

- A female RJ45 port for connection to an Ethernet network;
- A USB port (optional) for connection to storage devices.

Furthermore, the machine features a Wi Fi antenna, for connection to a wireless network.

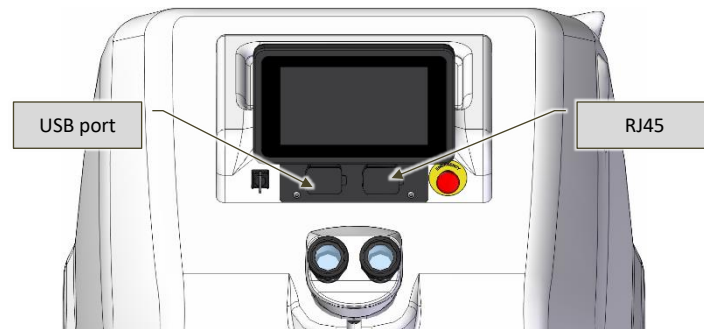

Fig. 6-13 - Position of connection points for networks and external units in the TAUWELD 200J

## **6.12 Management of machine keys**

The keys of the machine (interlock bypass connector and activation key) are delivered separately.

These keys must be managed by the Laser Safety Technician (LST).

Before activating the machine, the interlock contact must be connected to the safety system set up in the site where the machine is installed.

The activation key must be kept by a Supervisor, so that he/she may give it to trained staff only, in order to avoid unauthorized use of the machine.

## 7 Operation

### 7.1 Machine operation

TAUWELD 200J (Fig. 7-1) is a welding machine for artefacts made of metallic materials that uses electromagnetic laser radiation as an energy source for heating metals to melting temperature.

The machine consists of the following elements:

- Machine body;
- Stereomicroscope vision system binocular;
- Welding chamber;
- Control device.

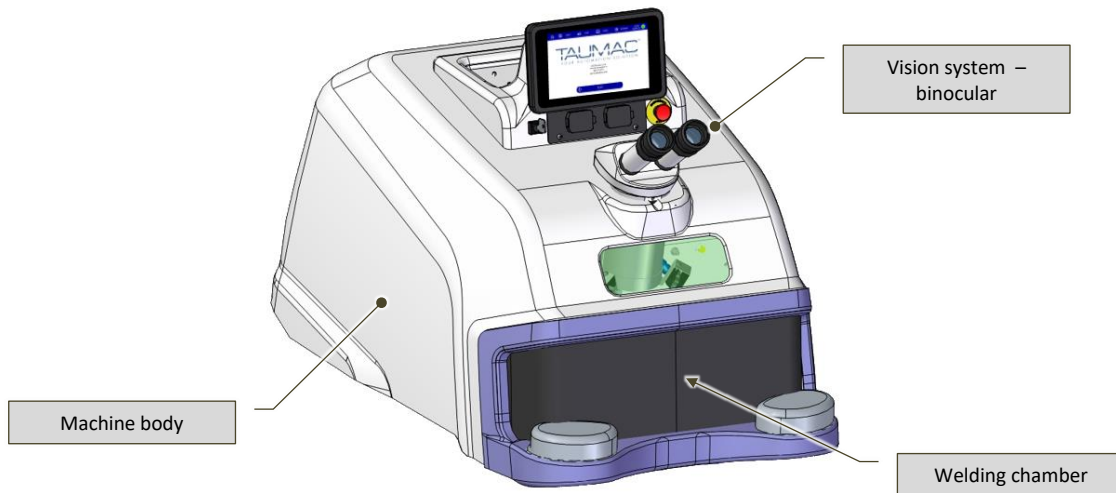

Fig. 7-1 – TAUWELD 200J

#### 7.1.1 Operating principle

The physical principle behind the generation of laser electromagnetic radiation is stimulated light emission. LASER is indeed the acronym of Light Amplification by Stimulated Emission of Radiation.

This means that lasers are light amplified by a photonic chain emission, originating from a first photon (light particle) that – by interacting with an excited atomic system – stimulates the emission of two photons which, in turn, interact with other atoms and so on, resulting in a “snowball” effect.

Excitement of the atomic system requires a suitable external energy supply to trigger the laser effect. This technique, known as “optical pumping”, is successful when the emitted radiation (in this case from a light source) involves an “active” material (one that emits laser light when stimulated) exciting the atoms as an effect of energy absorption.

Amplification of the laser effect is achieved by letting the light emitted by the material cross the material itself multiple times. This takes place by placing the active medium between two opposing mirrors, i.e. by building and “aligning” what is defined as an “optical resonator”.

When the resonator is “aligned” perfectly, the crystal and the mirrors are centered along the optical axis. The faces of the crystal, the front mirror and the face of the rear mirror closest to the crystal are parallel. In this optical configuration, the resonator extraction of laser energy is at maximum level, the beam is circular and its intensity is approximately uniform (consistent).

After being amplified, the laser beam is capable of exiting the resonator via the partially reflective mirror and being concentrated by a focus lens (with different focal length values), and can now be deviated into the welding chamber (in this case by a 45° mirror).

Focusing allows the energy to be concentrated in a specific spot (measuring just a few tenths of a millimeter), making the rising of temperature levels to metal melting points possible.

## Laser Welding machine - TAUWELD 200J

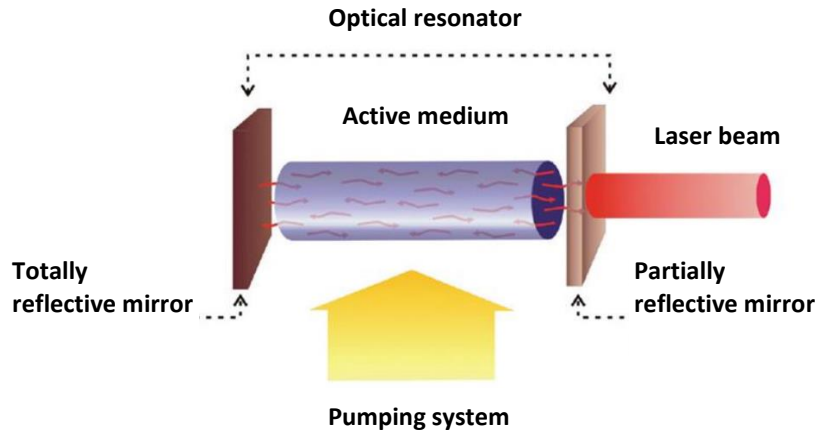

Fig. 7-2 – Operating principle



### 7.1.2 Specific glossary

The following **Tab. 7-1** features definitions of specific laser application terminology, for the purpose of making the contents of this manual more comprehensible.

<b>Term</b>	<b>Definition</b>
Aperture, diaphragm	Aperture means any opening in the laser device protective casing through which the laser radiation is emitted, thus allowing human access to the radiation in question. A diaphragm is an aperture which defines the surface on which the radiation is measured.
Beam	Laser radiation which can be characterized by direction, divergence, diameter or by scanning specifications. Diffuse radiation from a reflection is not considered a beam.
Beam expander	Combination of optical elements used to increase the diameter of a laser beam.
Beam stop device	Device that interrupts the trajectory of a laser beam.
Diffuse reflection	Change in the spatial distribution of a radiation beam when it is diffused in multiple directions by a surface or medium. A perfect diffuser eliminates any correlation between the directions of the incident and emergent radiation.
Class 4 laser device	Every laser device which allows human access to laser radiation exceeding accessible emission limits defined under Class 3B.
Stray laser radiation	Laser radiation that deviates from the expected beam trajectory. This includes unexpected secondary reflections from optical components located in the beam trajectory, radiation deviated by misaligned or damaged components and reflections from workpieces.
Direct viewing of the beam	All visual conditions in which the eye is exposed to a direct or specularly reflected laser beam. This is different from the viewing of diffuse radiations, for example.
Maintenance	Execution of regulations or procedures indicated in the user instructions supplied by the manufacturer along with the laser machinery, which must be performed by the user to ensure the machine meets expected performance levels. This does not include operation of the machine, nor support services.
Nominal Ocular Hazard Distance (NOHD)	Distance at which the irradiation or the energy beam exposure is equal to the maximum permissible exposure (MPE) for the cornea. If the NOHD includes the possibility of optically assisted vision, it is called "extended NOHD".
Pulsed laser	Laser that supplies its energy in the form of a single pulse or as a pulse train. Each pulse lasts less than 0,25 s.
Tool	Screwdriver, coin or any other object that can be used on screws or similar means of fastening.
Transmission factor	Ratio between the transmitted radiant flow and the incident flow in specifically set up conditions.
Visible radiation (light)	Every optical radiation capable of directly causing a visual perception (IEV 845-01-03). Indicates the electromagnetic radiation for which the wavelengths of the monochromatic components are included between 400 and 700 nm.
Workpiece	Object to be processed with laser radiation.

Tab. 7-1 – Specific glossary

### 7.1.3 Machine body

The body of the machine (Fig. 7-3) consists of an injection molded technopolymer casing.

The casing is closed with screws. It contains the laser source (lamp and resonator), all power and control devices for the laser source, the coolant system, the laser channeling and focus unit and the resonator shutter (a shutter controlled by an electromagnet, which has the function of interrupting the laser beam within the resonator).

The top of the machine body features the cylindrical connection (optical channel), while the vision system is connected.

The outermost part of the optical channel features a liquid crystal (LCD) filter that, if subjected to specific tension, will turn completely dark. The shutter will intervene, interrupting the operator's view in the binocular in the moment when the laser pulse causes the workpiece to melt.

The function of this device is to prevent the effect of glare caused by the visible radiation light flash emitted by the weld bath.

The welding chamber is located on the front side of the machine body.

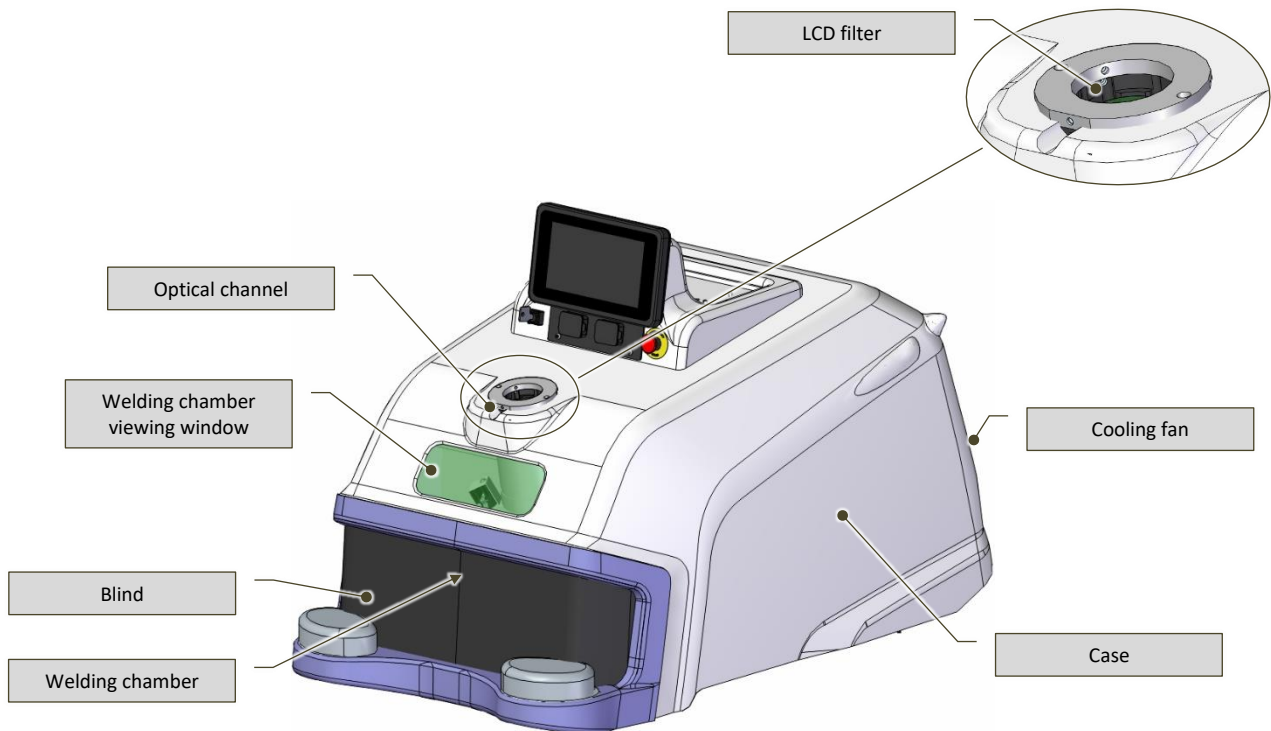

Fig. 7-3 – Body of the machine (image without binocular/visor)

The gas supply and cooling liquid top-up connections are located on the rear of the machine.

The power switch is located on the left side of the machine.

The cooling fan is located on the right side of the machine. (Fig. 7-3).

#### 7.1.4 Stereomicroscope vision system

The work area can be visualized via binocular stereoscopic microscope.

The vision system consists of an optical magnification system that allows the operator to focus on the laser target during welding operations.

This type of optical microscope is designed to provide stereoscopic vision of an object.

In the binocular (Fig. 7-4), this is achieved via two distinct and differently aligned optical paths within the microscope, both of which end with two lenses and two oculars.

These two optical paths offer the right and left eye images from different angulations.

The device consists of two articulated oculars. Each ocular features a ring for focusing ocular and for correcting any vision defects (dioptric correction, Fig. 7-5).

The binocular is supplied with two (removable) blinkers, which can be applied to the oculars if the operator is wearing prescription glasses.



Fig. 7-4 - Binocular



Fig. 7-5 – Dioptic correction ring

A filter (an optical glass that becomes frosted at a laser wavelength of 1064 nm) is installed within the vision system (in the optical tube).

This light grey and perfectly transparent filter becomes frosted at a laser wavelength of 1064 nm and therefore blocks entry in the oculars of the laser radiation generated by the source (Fig. 7-6)

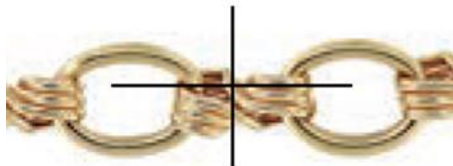

Fig. 7-6 – Example of display through the vision system

### 7.1.5 Welding chamber

The welding chamber is incorporated within the welding machine casing.

The access compartment of the welding chamber (Fig. 7-3), is closed by a sector curtain with the function of containing the laser radiation, as this may be diffused or reflected during welding operations (e.g. by the surface of welded parts or by tools used to support the welded parts).

The following elements are located inside the welding chamber:

- Laser radiation optical output channel, protected by a special protection glass featuring a fine crosshair aiming reticle;
- Extraction fan for smoke generated during welding operations;
- Mobile shield gas dispenser with controller;
- Fixed dispenser for compressed air;
- LED lights;
- Lighting regulation switch (white or cold light);
- Joystick for scrolling and editing operational laser settings.

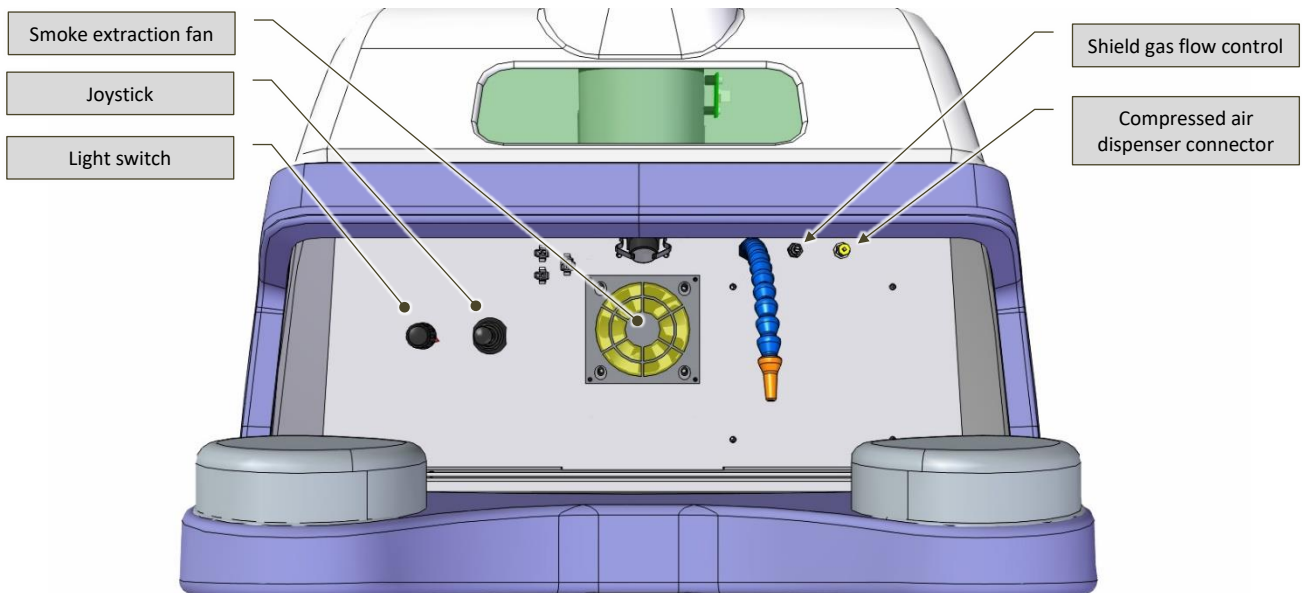

Fig. 7-7 – Welding chamber (without blind)

The optical channel is the channel through which the laser beam is introduced to the chamber.

This channel is closed by a protection glass (Fig. 7-8) which protects the optical channel from fused particle projections which may take place during welding operations.

A reticle pointer is engraved on the protection glass and helps aim the laser beam at the welding point.

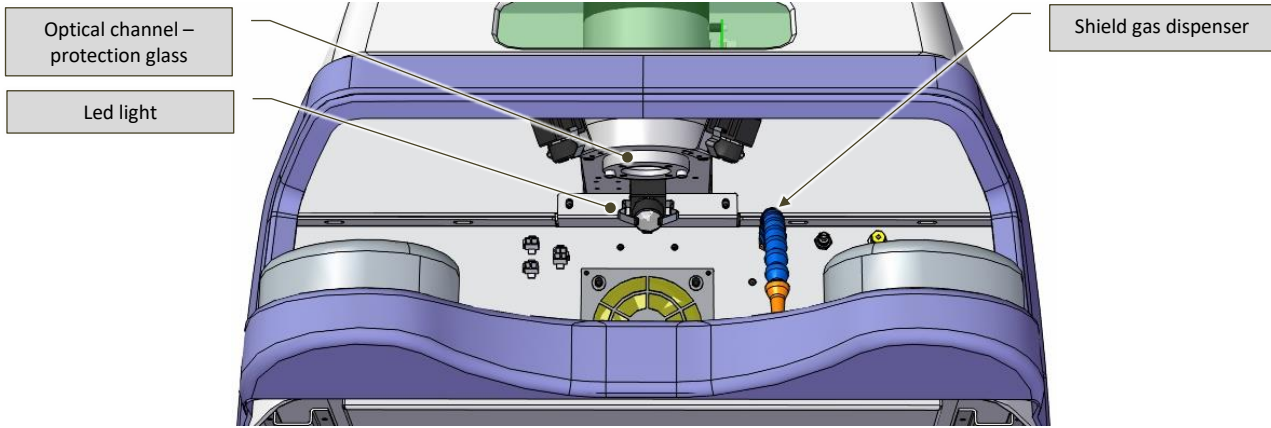

Fig. 7-8 – Optical channel – view from welding chamber

**7.2 Control device**

The following figures (Fig. 7-9, Fig. 7-10, Fig. 7-11) illustrate the control and emergency devices installed on TAUWELD 200J and described in Tab. 7-2.

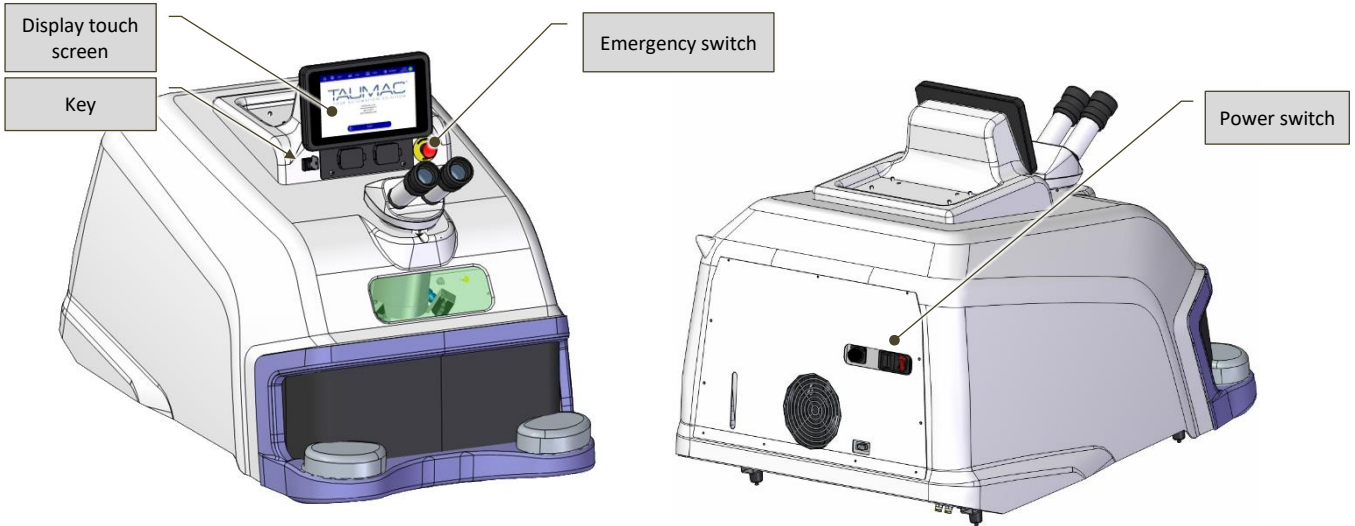

Fig. 7-9 – Control devices: located on the left in the TAUWELD 200J model

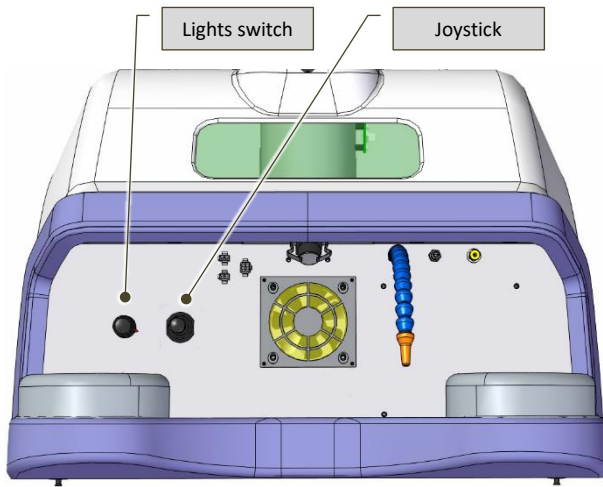







Fig. 7-10 – Control devices inside the welding chamber



Fig. 7-11 – Control pedal

**Laser Welding machine - TAUWELD 200J**

<b>CONTROL DEVICES</b>	
<i>Position</i>	<i>Description</i>
<p>Fig. 7-9</p> 	<p>General power switch:</p> <ul style="list-style-type: none"> <li>• <b>O</b>: the machine is disconnected from the electrical power supply;</li> <li>• <b>I</b>: the machine is electrically powered.</li> </ul>
<p>Fig. 7-9</p> 	<p>2-contact key selector (ignition key) command:</p> <ul style="list-style-type: none"> <li>• <b>LOCK</b> (to the left): machine off - machine shutdown procedure activated. In this position the key can be removed from the selector;</li> <li>• <b>STAND BY</b> (to the right): machine switched on with blocked resonator set to ON (active) which blocks the laser path.</li> </ul>
<p>Fig. 7-10</p> 	<p>Red emergency stop push-button.</p>
<p>Fig. 7-10</p> 	<p>Multi-position switch for turning the LED lights in the welding chamber on/off and for selecting their color (white or cold).</p>
<p>Fig. 7-10</p> 	<p>4-unstable-position control joystick:</p> <ul style="list-style-type: none"> <li>• <b>↑ SET UP</b> (move joystick upwards): increases the value of the underlined setting;</li> <li>• <b>↓ SET DOWN</b> (move joystick downwards): decreases the value of the underlined setting;</li> <li>• <b>← SET FUNCTION</b> (move joystick leftwards): selects the setting to the left of the currently displayed one, or shifts the selection underlining leftwards;</li> <li>• <b>→ SET FUNCTION</b> (move joystick rightwards): selects the setting to the right of the currently displayed one, or shifts the selection underlining rightwards;</li> </ul>
<p>Fig. 7-11</p> 	<p>Control pedal for activation of the laser emission (welding).</p>

Tab. 7-2 – Control and notification devices

### 7.2.1 Operator interface

In addition to the devices mentioned above, the machine also features an operator interface (Fig. 7-12).

The interface features a touch terminal (7" color touch screen display) which allows the operator to set the various operational parameters.

For information on how the operator interface software works, please refer to the specific section of this manual (paragraph 8.5).



Fig. 7-12 - Operator interface



### 7.3 Safety devices

The machine features a series of safety devices, illustrated in the following paragraphs.

#### 7.3.1 Emergency buttons

When pressed, the emergency buttons (Fig. 7-13), allow the operator to stop the machine in the event of emergencies.

Their protruding shape (push-buttons) makes them easy to push with the palm of a hand.

These buttons are always red and feature a small highlighter yellow ring at their base.

Once pushed, these buttons require manual unlocking, which is achieved by rotating the button clockwise or by pulling it outwards.

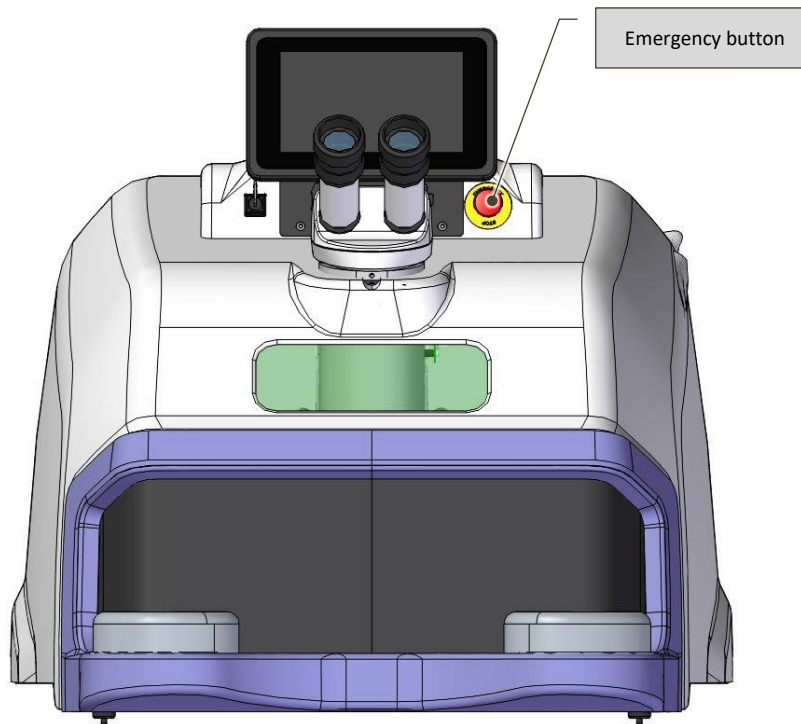

Fig. 7-13 – Emergency button (internal view of welding chamber)

### 7.3.2 Interlock

The interlock (Fig. 7-14) is a safety device (that must be activated **before using the machine for the first time**); failure to activate this device will block the laser and therefore stop TAUWELD 200J from operating.

In order to use the interlock, the contact on the foreseen safety device must be “remoted” (e.g.: coupled with opening of the door to the work environment, or of safety guards, if present).

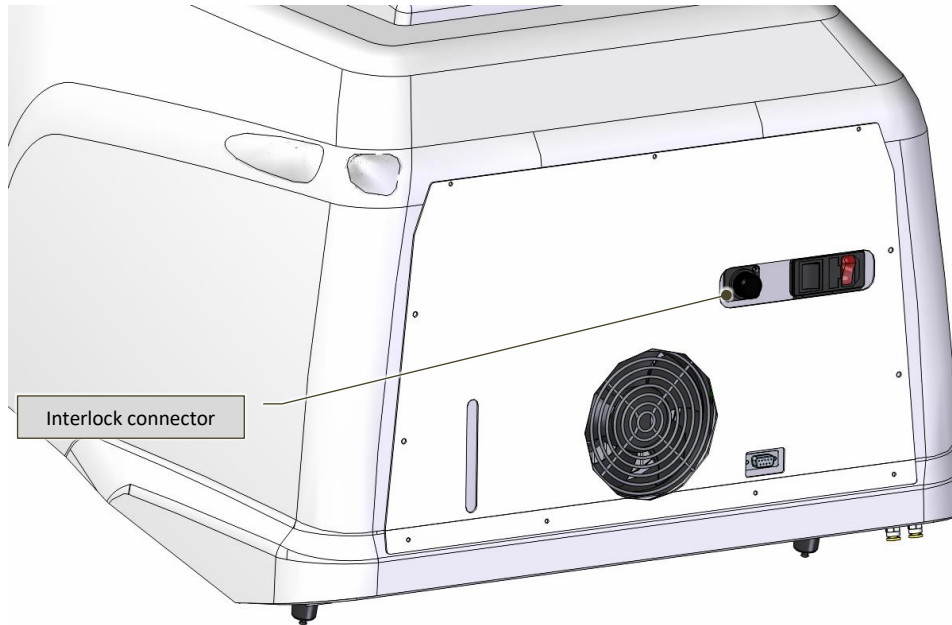

Fig. 7-14 – Interlock



**OBLIGATION!:** *The laser safety technician is in charge of managing the interlock (please refer to paragraph 4.11). The interlock must be connected to the foreseen safety system by qualified staff in charge of maintenance of the machine (please refer to paragraph 4.9). For further information on this installation process, please contact the manufacturer.*

### 7.3.3 Activation key

The activation key (Fig. 7-15) allows the operator to turn the machine on for use. The key must always be removed from the machine if left unattended, to avoid use by unauthorized staff.



Fig. 7-15 – Activation key (internal view of welding chamber)



**OBLIGATION!:** When not in use, the key must be kept by the laser safety technician (please refer to paragraph 4.11), who will only give it to personnel in charge of operating the machine and trained in the use of laser devices, who in turn will be responsible for returning the key at the end of their work shift.

### 7.3.4 Resonator shutter

This device consists of a small flag controlled by a spring-loaded rotary coil, located inside the laser resonator. The function of this device is to prevent the generation of undesired laser radiation.

When the machine is switched on (general switch on "I"), and the key switch is turned to READY, the shutter remains closed. Only once the laser is enabled by pressing the START control area, does the resonator shutter open, clearing the laser path. At this point, the welding machine is ready for normal operation.

By turning the key to OFF, the machine will run the program to turn the laser source off, the resonator shutter will close and the machine will monitor that the shutting process took place correctly and within the foreseen time frame.

The resonator shutter becomes operational (activates) also in the following events:

- If any errors are detected;
- When the activation key is removed - "LOCK" state;
- If the emergency button is pushed;
- If an interruption in the electrical power supply occurs (for example, if the electrical plug is disconnected or if the general switch is set to "O");
- If the interlock device is triggered.

### 7.3.5 Microscope shutter

This device consists of a liquid crystal (LCD) filter that, when subjected to a specific tension, turns completely dark. It is located between the 45° mirror and the focus lens of the microscope.

The shutter interrupts the operator's visual path through the microscope in the moment in which the laser shot melts the workpiece.

The function of this device is to stop the operator from being dazzled by the visible radiation flash of light generated by the weld pool.

This protection prevents anomalous diffusion of laser radiation towards the operator's eyes.

The normal condition of the device is when the microscope shutter is closed, thus allowing for use of the microscope in any given moment.

Once the laser emission is enabled (resonator shutter open), the operating logic of the microscope shutter is the following:

- Pressure on the control pedal;
- The microprocessor detects the closure of the pedal contact and commands the microscope shutter to close;
- The microprocessor enables activation of the laser lamp;
- The status of the microscope shutter is ON as long as the laser lamp is activated, plus a reasonable time frame to allow the weld pool to cool down and lose its luminosity;
- Return to standby status, with detection of full opening of the microscope shutter.

### 7.3.6 Microscope infrared filter

The infrared filter is an optical glass, opaque at a laser radiation level of 1064 nm, which impedes passage in any direction of the laser radiation in use; it is located within the optical tube.

It appears light grey and perfectly transparent.

The function of this filter is to protect the operator's eyes from stray laser radiations in the optic path of the microscope, even if these are highly improbable in this area.

### 7.3.7 Welding chamber infrared filter

The welding chamber infrared filter is an optical glass, which becomes frosted at a laser radiation level of 1064 nm, which constitutes the inspection window of the welding chamber (Fig. 7-3).

This filter is light grey and perfectly transparent.

The filter is easy to replace.

### 7.3.8 Guards

Guards are parts of a machine used specifically to provide protection via the presence of a physical barrier. Based on their build, guards can be called headset, lid, door, total segregation guard, etc.

Guards can operate autonomously and are only functional when closed or associated with an interlock device, which may or may not feature a system for blocking of the guard; when it does, protection is guaranteed regardless of the position of the guard.

Please find below a description of the types of guard used on this machine (Fig. 7-16 and Fig. 7-17):

- **Fixed guard** – this guard is held in position (i.e. closed) either permanently (via welding, etc.) or with fastening elements (screws, nuts, etc.), which make it impossible to remove/open without using tools;
- **Flexible shield** – Closes access to the welding chamber. Allows for introduction of the workpieces, limits the emission of diffuse or reflected radiation and prevents any inert shield gas leaks from the welding chamber (if used during the welding stages), thus effectively protecting the metals from oxidation.

**Laser Welding machine - TAUWELD 200J**

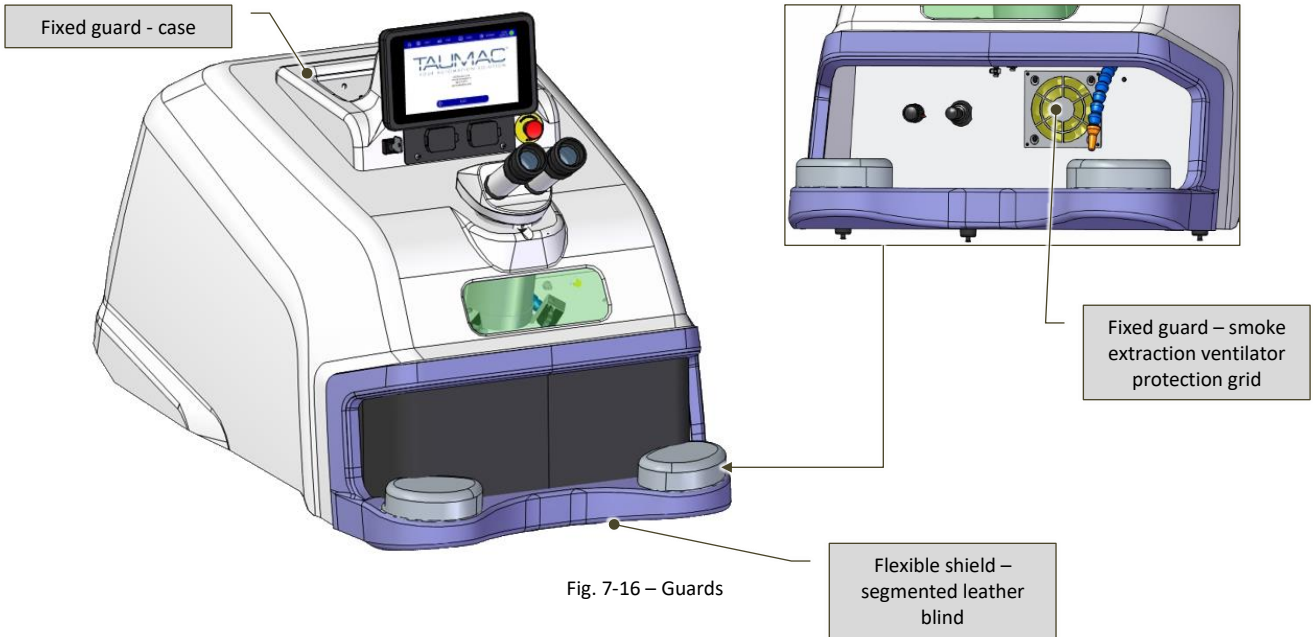

## 7.4 Preliminary operations

### 7.4.1 Insertion of the cooling liquid

The cooling liquid (distilled and deionized water) is required to cool the laser source.

The machine is supplied with a container featuring the correct quantity of cooling liquid.



**OBLIGATION!:** Use only the cooling liquid container supplied with the machine.

To insert the liquid, please proceed as indicated below:

- Connect the supplied cooling liquid top-up tube to the female connector (Fig. 7-18) on the rear of the machine;
- Manually remove the black cap (Fig. 7-18) from the “overflow” tube located on the upper rear of the machine;



**WARNING!:** Hold the overflow tube firmly (Fig. 7-18) when removing its black cap, to ensure it does not become dislodged.

- Hold the free end of the top-up tube, insert the supplied funnel in this end and, while holding the tube in vertical position, fill the tank with cooling liquid (Fig. 7-19): the correct cooling liquid level in the tank is reached when water starts flowing out of the upper “overflow” tube;

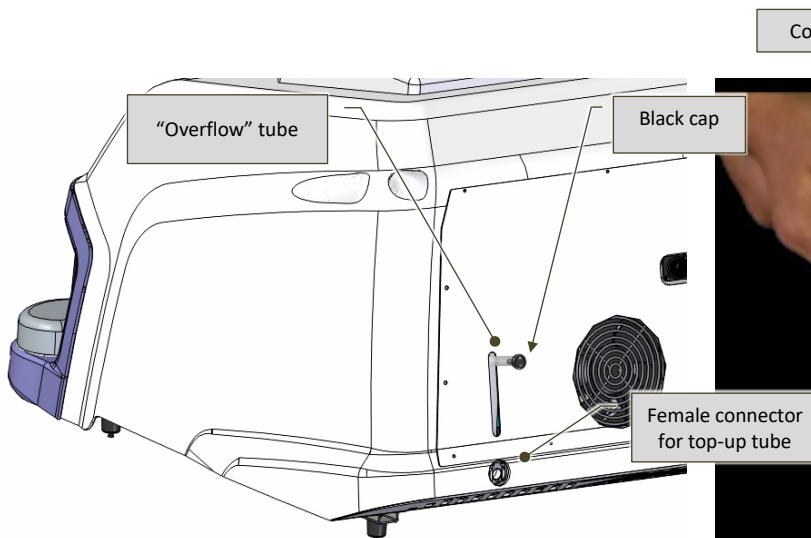

Fig. 7-18 – Cooling liquid top-up – rear view of the machine

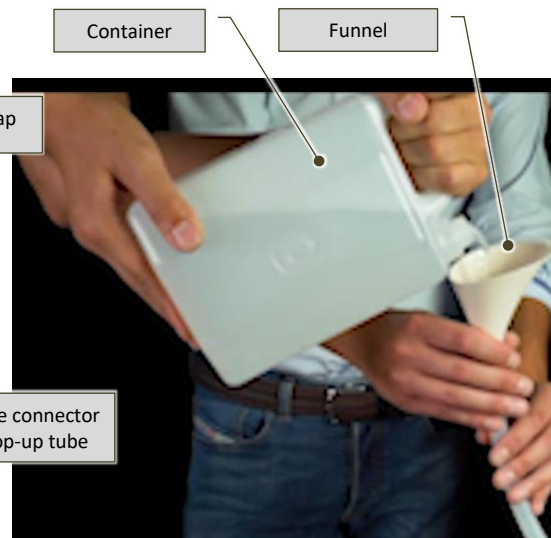

Fig. 7-19 – Insertion of the cooling liquid

- Release the top-up tube from the lower female connector by pressing on the release tooth;
- Place the top-up tube and the funnel in the box for transporting the machine or in another environment/room used for its storage;
- Purge any air bubbles from the circuit:
  - Switch the machine power to on (please refer to paragraph 8.3);
  - Insert the activation key;
  - If Error 02 TEST FLUX H2O occurs, purge any air bubbles inside the circuit:
  - Power up the machine (see paragraph 8.3);
  - If the operator panel displays the warning message “ERROR 02 TEST FLUX H2O”, remove the key - OFF and repeat the previous two steps until all air in the cooling circuit has been purged;
  - Turn off the machine (please refer to paragraph 8.6.4) and place the black cap back on the overflow tube.

## 7.5 Preliminary regulation operations



**WARNING!: Failure to perform preliminary regulation operations can cause damage to the machine and/or installed equipment.**







**WARNING!: All preliminary regulation operations must be performed with the machine switched off.  
If certain regulation operations require activation of the machine devices, strictly follow indications listed in chapter 8 "Operation instructions".**

Before starting the machine, you may need to perform a series of preliminary regulation operations described in the following paragraphs.

### 7.5.1 Regulation of the binocular

Regulation of the binocular requires particular care, as imprecise regulation of this device can jeopardize the entire focus process and consequently the quality of welding operations.

The right ocular features a reticle pointer which must be aligned with the laser in order to start welding in the correct position. To regulate the binocular, please follow the sequence of operations described in the following Tab. 7-3.

Symbol	Action	Feedback / notes
	<ul style="list-style-type: none"> <li>Use the ring to regulate both oculars on the neutral diopter (●);</li> <li>Keep using the ring (+ / -) to focus your view;</li> <li>Operate on each single ocular to perform dioptic corrections, if required.</li> </ul>	 <p>Fig. 7-20 – Focus / dioptic regulation</p>
	<p><i>If you do <b>not</b> use glasses, we recommend using the (removable) eye cups supplied with the machine.</i></p>	 <p>Fig. 7-21 - Eye cups</p>
	<p>Place an object under the focal lens at a height where it is in focus and then proceed to regulate the binocular width so that you have a single shadowless circle and a clear view when observing its contents.</p>	 <p>Fig. 7-22 – Binocular width</p>

Tab. 7-3 – Regulation of the binocular

## 8 Operation instructions

### 8.1 Safety instructions



**WARNING!** Failure to observe the following safety instructions may result in injuries, death or damage to the machine.

This machine must be operated exclusively by “qualified staff”, based on the correspondent indications included in this manual.

**Please find below a series of checks that must mandatorily be performed before and after performing operations with the machine.**

#### 8.1.1 Necessary checks before starting the machine

- Check that attire worn by the operator is suitable. The operator must not wear wide clothes, wristwatches, rings, necklaces and similar objects. Long hair must be tied back;
- Check that no individuals uninvolved in operations with the machine are present in the operational area of the machine;
- Make sure that no foreign objects (tools, rags, etc.) are left inside the welding chamber, in particular specular surfaces such as chrome-plated details, mirrors, aluminum films, etc.: these surfaces may cause hazardous reflections of the laser beam within the welding chamber;
- If operations require the use of personal protective equipment, check that this is compliant with currently effective correspondent laws.

#### 8.1.2 Required checks and behavior after starting the machine

- Immediately stop the machine if, once started, it is making unusual noises. Restart the machine after removing the source of the noise;
- Immediately stop the machine if the operator panel displays error warnings. Restart the machine only once the cause for the error has been identified and solved;
- During operations, remain within the operator area;
- Never leave the machine unguarded during operations.
- Do not allow anyone near the machine during operations;
- Monitor that the machine performs its work cycle correctly, and stop it immediately in the event of anomalous operations;
- Do not deactivate protection and safety devices;
- Always remove the activation key if leaving the machine unattended.

#### 8.1.3 Behavior in the event of fire/incipient fire

- In the event of fire or incipient fire, the operator must immediately shut down all aspiration systems in the machine(if present); Ventilation supplies oxygen-rich air and facilitates the propagation of fires;
- Quickly use hand-held extinguishers (we recommend the use of CO2 extinguishers). In the absence of aspiration, extinguishing agents can potentially make the air unbreathable. Act promptly and with great care. Remain within the hazardous environment as little as possible;
- If the fire cannot be controlled, abandon the building and make sure to close the doors.



#### 8.1.4 Non permissible operations



**The following uses of the welding machine are explicitly prohibited:**

- The TAUWELD 200J welding machine is designed for professional use.
- **Use of the welding machine when it presents signs of tampering or damage (in particular cracks in the casing and protection curtain) or when it is emitting different noises or signals in panel control IS PROHIBITED. Do not try to repair the welding machine. Only the manufacturer is authorized to repair the welding machine.**
- **When using the welding machine, observation of the welding chamber through the workpiece insertion opening is PROHIBITED. Use only the inspection window to look into the welding chamber.**
- **Direct observation of the laser source IS PROHIBITED, even when wearing personal protective eye equipment! No personal protective eye equipment is capable of protecting the eyes from direct radiation!**
- **Use of the welding machine for the welding of flammable or combustible materials IS PROHIBITED. We remind the user that many metals (e.g. magnesium, sodium, aluminum) are easily flammable (especially when small in dimensions).**
- **Introducing or depositing different materials than the workpieces – such as tools, supports or other objects, for example – IS PROHIBITED. The welding chamber must always be left empty. Any tools used to support the workpiece must be made of non-reflective materials.**
- **Use of the welding machine for the welding of different materials than those indicated in the Tab. 5-7 – of this manual IS PROHIBITED. If you need to weld different materials, we invite you to contact the manufacturer. Never try to weld different materials than those indicated in the table;**
- **Use of the machine in environments characterized by a potentially explosive atmosphere (due to flammable dusts or gases) IS PROHIBITED. Laser radiation can trigger fires or explosions.**

#### 8.1.5 Requirements for safe use



**WARNING!: safe use of the welding machine is dependent on strict observation of the following indications:**

- **Use the welding machine only after wearing suitable personal protective equipment to protect your eyes and skin from laser radiation effects, based on requirements set by your Employer;**
- **Pay particular attention when welding reflective materials. Reflective surfaces can deviate the laser beam towards the opening of the welding chamber. If this occurs, only the protection curtain and suitable personal protective equipment can guarantee the operator's safety;**
- **Before performing any welding operations, always make sure that the chamber protection curtain is undamaged and positioned in such a way that it covers all possible openings of the chamber;**
- **Although it features a system for extracting smoke from the chamber, the welding machine does not guarantee the filtering of fumes. Re-insertion of smoke in the work environment can be dangerous. Carefully assess the hazard represented by emissions during welding. You may need to use a localized extraction system and/or personal protective equipment. In any case, always observe the following indications during welding operations:**
  - **Keep your head far away from smoke. Do not inhale any fumes;**
  - **Do not cover any part of the machine;**
  - **Carefully read the instructions on the various types of material which can be laser-welded;**
  - **Use the welding machine in a suitably ventilated environment;**
  - **Only weld clean surfaces. Many substances used to degrease or clean workpieces, as well as any inclusions in the materials, may react to the laser energy by producing fumes which can be dangerous for your health.**

#### 8.1.6 Non-evident hazards

**WARNING!: Both the qualified operator and the technical personnel of Taumac S.r.l. in charge of operating on the machine must be aware of additional less evident hazards that are often underestimated in production sites:**

- **Protruding parts of the machine;**
- **Parts of the machine which may present sharp surfaces and/or edges;**



- **Electrostatic charges that are still present after switching off the machine;**
- **Hot parts of the machine.**

## 8.2 Preparation for start-up

Before starting TAUWELD 200J you must make sure that the electrical system of the building where the machine is installed is activated. Please refer to indications supplied by the respective manufacture-installation service to activate the electrical system. Before starting the machine, make sure that the suction system (not supplied with the machine) is already active and functioning.

## 8.3 Tensioning

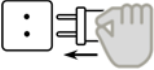
Follow the sequence of operations described in the following Tab. 8-1 to perform the tensioning of TAUWELD 200J.

<i>Symbol</i>	<i>Action</i>	<i>Feedback / notes</i>
	Check that the plug is plugged into the network socket (please refer to paragraph 6.8).	
	Check that the red "EMERGENCY" button is not pressed. If this is the case, reset the button.	
	Turn the power switch to "I"	The operator panel display will turn on and the home page will display the message "Machine locked. Turn the key."









Tab. 8-1 – Tensioning

## 8.4 Start-up

### 8.4.1 Operation

After switching TAUWELD 200J on (tensioning), you need to enable its operation (insertion).

To enable TAUWELD 200J to operate, please follow the sequence of operations described in the following Tab. 8-2.

Symbol	Action	Feedback / notes
	Check that all preliminary operations and calibrations have been performed (please refer to paragraphs 7.4 and 7.5).	
	Insert the activation key in the switch and the machine turn it to "STAND BY".	The home page on the operator panel will display the message "Laser in stand-by. Press start."
	Access the "laser operation settings" page on the operator panel, by pressing the <b>LASER</b> control area and check that all parameters are set to zero.	The machine cannot be used if the operation parameters are not set to zero: please refer to paragraph 8.7 or contact the Support Service.
	Access the home page on the operator panel and press the <b>START</b> control area.	<ul style="list-style-type: none"> <li>The shutter resonator will deactivate.</li> <li>The display will show the laser operation settings page.</li> <li>The STATUS notification area for the machine will display the following message "Laser activated. Check settings."</li> </ul>
	If necessary, on the basis of the type of welding operation, the operator can load the laser operation settings saved in one of the existent programs or edit the settings of one of these programs. Please refer to the recommended welding settings in Tab. 8-3.	<b>The settings values can also be edited by using the joystick.</b>
	If necessary, calibrate the shield gas flow by using the specific controller inside the welding chamber (Fig. 7-7).	
	Manually introduce the workpiece(s) into the welding chamber – checking their position through the visual system – and focus the aim on the welding point by using the crosshairs reticle.	 According to the size of the product, the operator can also use plastic pincers to perform this operation. Please refer to paragraph 5.6 for information on permissible products.
	Press the control pedal to weld. <i>If the repetition rate is deactivated (the display will show two dashes, "--"), pressing the pedal will generate a single shot.</i> <i>If the repetition rate is activated (the display will show a value in Hz), pressing the pedal will generate a correspondent number of shots per second.</i> <i>To weld again, press the pedal again.</i>	For pulse characteristics (based on the product to be welded), please refer to Tab. 8-3.
	<b>We recommend carrying out some preliminary welding tests on a sample of the material you intend to weld, in order to identify the correct welding setting among the twelve available options.</b>	

Tab. 8-2 – Operation

#### 8.4.1.1 Welding settings

TAUWELD 200J can store up to 100 (one hundred) different work programs.

In any case, we recommend the following welding settings (Tab. 8-3), based on the materials requiring welding.



**WARNING!:** INDICATIVE data! Always try, before starting the welding work, on sample pieces, as the resulting weld depends very much on the alloys used.

<i>Material</i>	<i>Power [kW]</i>	<i>Spot [mm]</i>	<i>Time [ms]</i>	<i>Frequency [Hz]</i>	<i>Wave</i>
THIN YELLOW GOLD	2,0	0,2	2,0	5,0	SLO+
YELLOW GOLD THREAD	2,4	0,4	2,4	6,5	SLO+
YELLOW GOLD COATING	3,6	0,7	3,6	6,5	SLO+
THIN WHITE GOLD	1,5	0,2	1,6	6,5	SLO
WHITE GOLD THREAD	1,7	0,4	1,7	6,5	SLO
WHITE GOLD COATING	2,3	0,8	2,1	6,5	SLO
THIN RED GOLD	1,6	0,2	1,9	5	SLO+
RED GOLD THREAD	1,8	0,3	2,2	5	SLO+
RED GOLD COATING	3,2	0,6	3,1	6,5	SLO+
THIN SILVER	3,7	0,3	3,7	5	NORM
SILVER THREAD	4,2	0,3	4,2	5	NORM
SILVER COATING	4,5	0,4	4,5	4	NORM
THIN PLATINUM	1,8	0,4	0,8	5	NORM
PLATINUM THREAD	1,8	0,5	1	1,6	NORM
PLATINUM COATING	2,2	0,8	1,8	1,9	NORM
THIN STEEL	1	0,3	1	6	NORM
STEEL THREAD	1,2	0,5	1,2	7	NORM
STEEL COATING	1,8	0,7	1,8	7	NORM
THIN TITANIUM	1,8	0,7	1,8	7	NORM
TITANIUM THREAD	1	0,2	0,2	2,5	NORM
TITANIUM COATING	1,0	0,2	0,2	2,5	NORM
THIN PALLADIUM	1,6	0,2	1,3	5,0	NORM
PALLADIUM THREAD	1,8	0,5	1,6	6,5	NORM
PALLADIUM COATING	2,4	0,7	1,8	8	NORM
THIN GERMAN SILVER	1,6	0,7	1,4	5	NORM
GERMAN SILVER THREAD	1,4	0,8	1,4	7	NORM
GERMAN SILVER COATING	1	0,9	1,9	8	NORM

Tab. 8-3 – Welding settings

## 8.5 Operator panel

This paragraph describes all the settings that can be edited by using the operator interface (operator panel).

The operator panel terminal is a “touch screen” (or tactile terminal), allowing the operator to send commands and/or edit machine settings by simply using his/her finger to press the control areas on the terminal corresponding to the chosen command.



**WARNING!** When using the “touch screen” terminal, make sure to press the displayed commands delicately and without using any sharp objects.



**WARNING!** Do not clean the “touch screen” terminal with aggressive solvents or abrasive products.

### 8.5.1 Menu bar

The upper part of the operator panel pages (with a few exceptions) features a menu bar which allows the operator to promptly access the main pages.

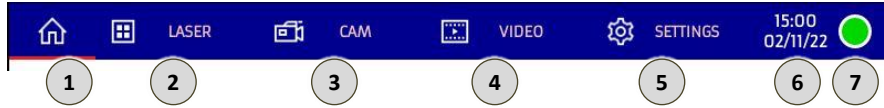

Fig. 8-23 – Menu bar

- 1 When pressed, this control area allows the operator to access the “Home” page (paragraph 8.5.2).
- 2 When pressed, this control area allows the operator to access the “Laser” operation settings page (paragraph 8.5.3).
- 3 When pressed, this control area allows the operator to access the “Cam” camera operation settings page (paragraph 8.5.4).
- 4 When pressed, this control area allows the operator to access the “Video” page (paragraph 8.5.5).
- 5 When pressed, this control area allows the operator to access the “Settings” page (paragraph 8.5.6).
- 6 Area displaying the current date and time.

View-only area displaying the laser status, which is indicated by a dot of the following colors:

- 7
  - GREEN, indicates the machine is running;
  - Flashing YELLOW, indicates the laser is ready to weld;
  - RED, indicates the laser is in use (pedal pressed);
  - Continuous RED with “ALARM!” message, flags an error (please refer to Tab. 8-4 for details).

### 8.5.2 “Home” page



Fig. 8-2 – “Home” page

When pressed, this control area allows the operator to access the “Language” settings page.

- 1 This page (Fig. 8-3) allows the operator to set the language of all texts on the pages and on the alphanumeric keyboard for data input.

The operator can return to the home page by pressing the  control area on the Language page.



Fig. 8-3 – Language page

- 2 When pressed, this control area allows the operator to access the user manual of the machine.

When pressed, this control area allows the operator to view the manufacturer contact details.

- 3 The operator can return to the home page by pressing the  EXIT control on the Contacts page (Fig. 8-4).



Fig. 8-4 – Contacts page

- 4 Area displaying the laser status and the action required to proceed: “Laser stand-by. Press start” or “Laser active. Check settings or “MACHINE LOCKED TURN THE KEY TO ON”.
- 5 When pressed, this control area allows the operator to prepare the machine for normal operation (the resonator shutter deactivates and the laser is ready for use) and to access the “Laser” operation settings page (paragraph 8.5.3).

### 8.5.3 “Laser” operation settings page

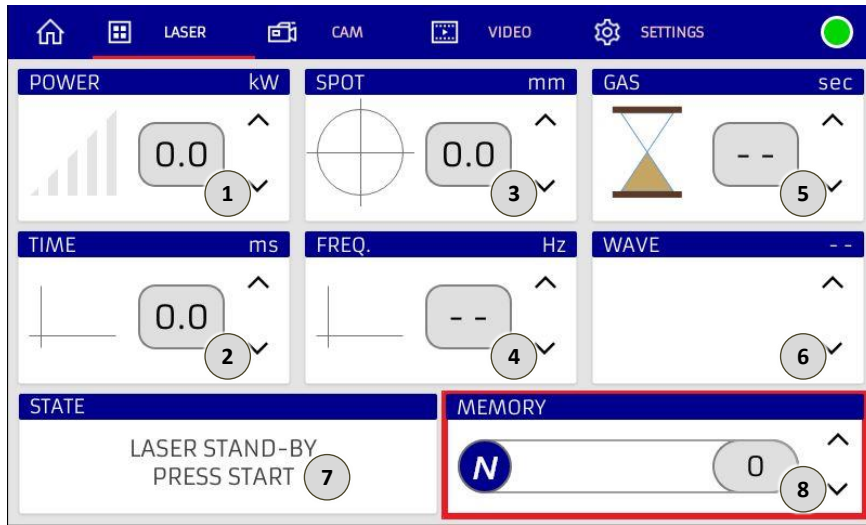

Fig. 8-5 – “Laser” operation settings page

- 1 This display area shows the power, in kilowatts, of the welding shot set for the selected welding program; the stored ID number of the program is indicated under item 8.  
Next to this area you will find the  and  controls. When pressed, these controls allow the operator to increase or decrease the set value.
- 2 This display area shows the duration, in milliseconds, of the welding shot set for the selected welding program; the stored ID number of the program is indicated under item 8.  
Next to this area you will find the  and  controls. When pressed, these controls allow the operator to increase or decrease the set value.
- 3 This display area shows the diameter, in millimeters, of the laser beam focus point on the workpiece, as set for the selected welding program; the stored ID number of the program is indicated under item 8.  
Next to this area you will find the  and  controls. When pressed, these controls allow the operator to increase or decrease the set value.
- 4 This display area shows the repetition rate of the laser pulse, in hertz, set for the selected welding program; the stored ID number of the program is indicated under item 8.  
Next to this area you will find the  and  controls. When pressed, these controls allow the operator to increase or decrease the set value.  
Once the minimum permissible value has been reached, pressing the  control again will cancel the repeated beam trigger function (thus, the machine will generate a single laser shot): in this case, the display will show two dashes, “ - - ”.  
*Note: In any case, the permissible repetition rate value is connected to the power (Kw) and time (ms) settings. It is impossible to work with high power settings and time values set at the maximum repetition rate value, as an auto-adjustment function will decrease the repetition rate value in relation to the power output.*
- 5 This display area shows the countdown for the remaining time, in seconds, during which inert gas is dispensed to protect the welding operation after the latest shot.  
Next to this area you will find the  and  controls. When pressed, these controls allow the operator to increase or decrease the set value.  
*Note: When this parameter is set to “- -” (two dashes), welding will take place without using the inert shield gas.*
- 6 This display area shows the laser pulse waveform set for the selected welding program; the stored ID number of the program is indicated under item 8.  
Next to this area you will find the  and  controls. When pressed, these controls allow the operator to select the wave form from the 5 available options.  
*Note: The default laser pulse waveform of the programs is set as “normal” (squared wave).*
- 7 View-only area displaying the interface messages indicating the status of the machine, including minor error warnings.



## Laser Welding machine - TAUWELD 200J

This control area displays the ID number of the welding program (in the memory index) the machine is currently set to perform. In addition to this number, the display shows the name associated with this program, which generally corresponds to the type of metal requiring welding.

8

When pressed, this control area allows the operator to change the name of the program (Fig. 8-6) and save it in the desired position (in the memory index).

Next to this area you will find the  and  controls. When pressed, these controls allow the operator to change the number of the program (in the memory index) to a different number among the 99 available options.

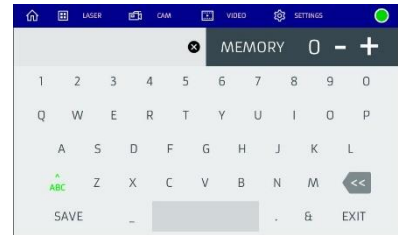

Fig. 8-6 – Program name input page

### 8.5.4 Cam page

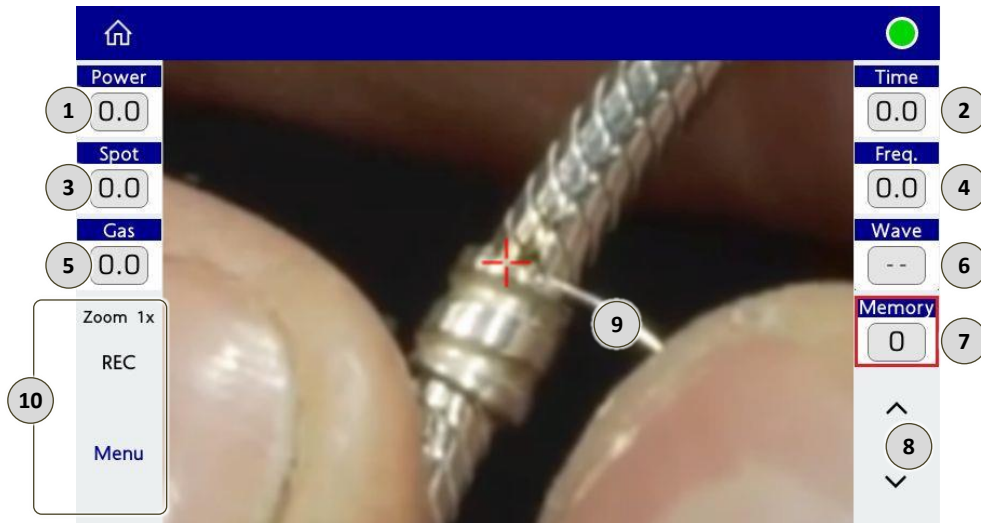

Fig. 8-7 – “Cam” page

- 1 This display area shows the power, in kilowatts, of the currently set welding shot. When pressed, it will become selected to allow the operator to change the value by using the controls described under item 8.
- 2 This display area shows the duration, in milliseconds, of the currently set welding shot. When pressed, it will become selected to allow the operator to change the value by using the controls described under item 8.
- 3 This display area shows the currently set diameter, in millimeters, of the laser beam focus point on the workpiece. When pressed, it will become selected to allow the operator to change the value by using the controls described under item 8.
- 4 This display area shows the repetition rate, in hertz, of the currently set laser pulse. When pressed, it will become selected to allow the operator to change the value by using the controls described under item 8.
- 5 This display area shows the countdown for the remaining time, in seconds, during which inert gas is dispensed to protect the welding operation after the latest shot. When pressed, it will become selected to allow the operator to change the value by using the controls described under item 8.  
*Note: When this parameter is set to “0” (zero), welding will take place without using the inert shield gas.*
- 6 This display area shows the currently set laser pulse waveform. When pressed, it will become selected to allow the operator to change the value by using the controls described under item 8.
- 7 This display area shows the ID number of the welding program (in the memory index) the machine is currently set to perform. When pressed, it will become selected to allow the operator to change the value by using the controls described under item 8.
- 8 When pressed, these control areas allow the operator to increase or decrease the value displayed for one of the welding settings described under items 1 to 7. The edited setting is the one highlighted by an orange border.
- 9 Camera display area.  
  
When pressed, these control areas allow the operator to:
  - Zoom: set the zoom level of the camera;
- 10
  - REC: Start video recording (the writing turns red and blinks). The next time you press, the recording stops;
  - Menu: Access the “Crosshairs” page for calibration (paragraph 8.5.5);

### 8.5.5 “Crosshairs” page

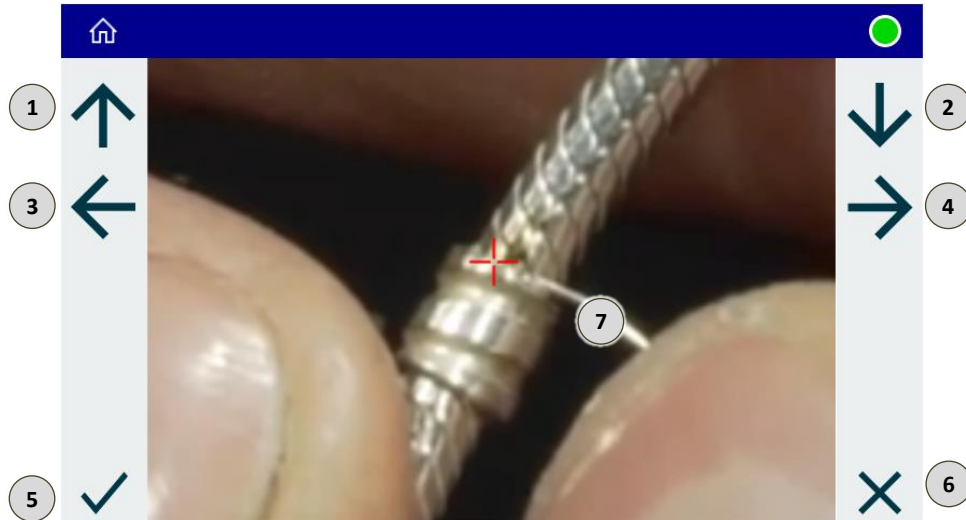

Fig. 8-8 – “Crosshairs” page

- 1 When pressed, this control area allows the operator to shift the crosshairs upwards in the display area described under item 7.
- 2 When pressed, this control area allows the operator to shift the crosshairs downwards in the display area described under item 7.
- 3 When pressed, this control area allows the operator to shift the crosshairs leftwards in the display area described under item 7.
- 4 When pressed, this control area allows the operator to shift the crosshairs rightwards in the display area described under item 7.
- 5 When pressed, this control area allows the operator to save any edits made on the page.
- 6 When pressed, this control area allows the operator to exit without saving any edits made on the page.
- 7 Crosshairs aiming display area.

### 8.5.6 “Video” page

This page allows the operator to watch tutorial videos on how to use the machine or how to perform a series of maintenance operations, pre-uploaded to the internal storage of the machine).

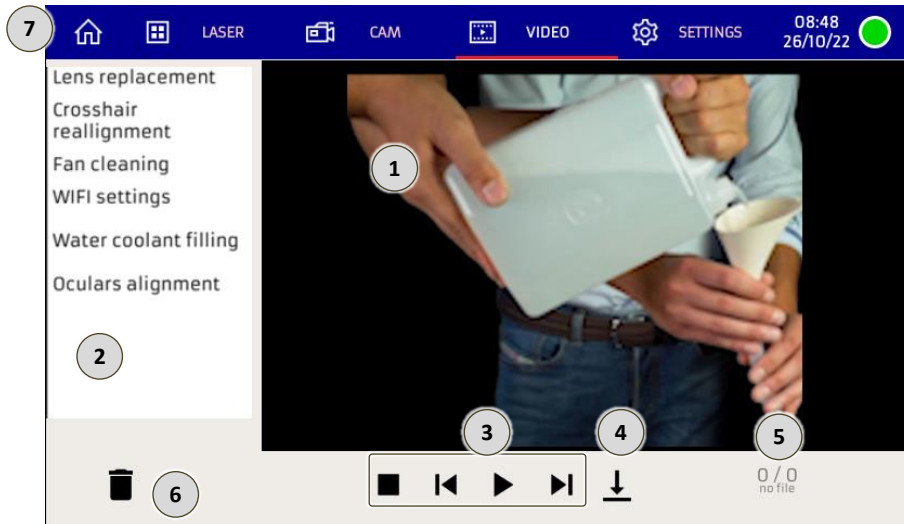

Fig. 8-31 – “Video” page

- ① Video display area.
- ② Available video display and selection area.
- ③ When pressed, these control areas allow the operator to manage the video playback: stop, back to start, play, next video.
- ④ When pressed, this control area allows the operator to download the video onto an external storage device (USB).
- ⑤ This display area shows the current video number, out of the total number of videos saved in storage.
- ⑥ Command area for deleting the selected video.
- ⑦ When pressed, this control area allows the operator to return to the “Home” page (paragraph 8.5.2).

### 8.5.7 Settings page

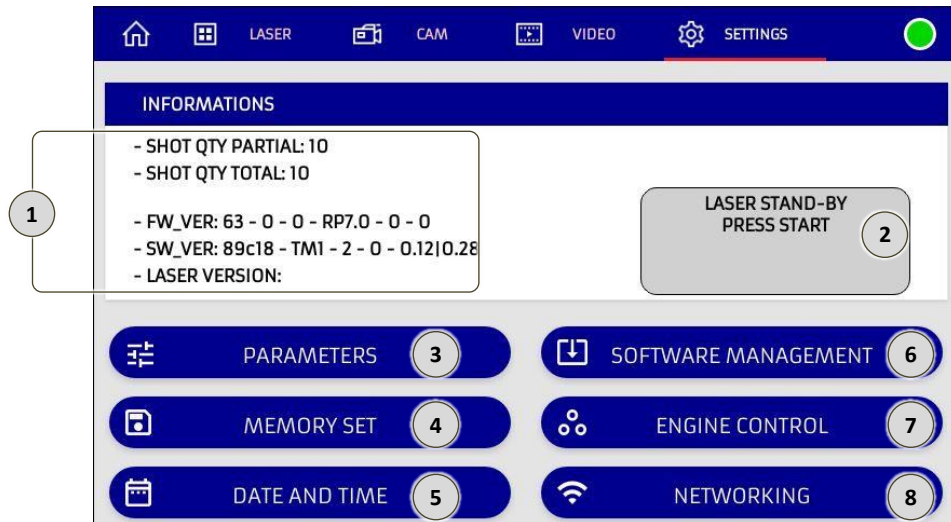

Fig. 8-10 – Settings page

View-only area displaying:

- The partial number of shots generated by the machine;
  - The total number of total shots generated by the machine;
  - The firmware version number of the machine;
  - The software version number of the machine;
- The number of the laser version assembled on the machine.

1

2

View-only area displaying the current status of the machine.

3

When pressed, this control area allows the operator to access the “Parameters” page (paragraph 8.5.7.1).

4

When pressed, this control area allows the operator to access the “Memory set” page (paragraph 8.5.7.3).

5

When pressed, this control area allows the operator to access the date/time settings page (paragraph 8.5.7.4).

6

When pressed, this control area allows the operator to access the software management page (paragraph 8.5.7.5).

7

This control area is not available for use.

8

When pressed, this control area allows the operator to access the network settings page (paragraph 8.5.7.6).

**8.5.7.1 Parameters page**

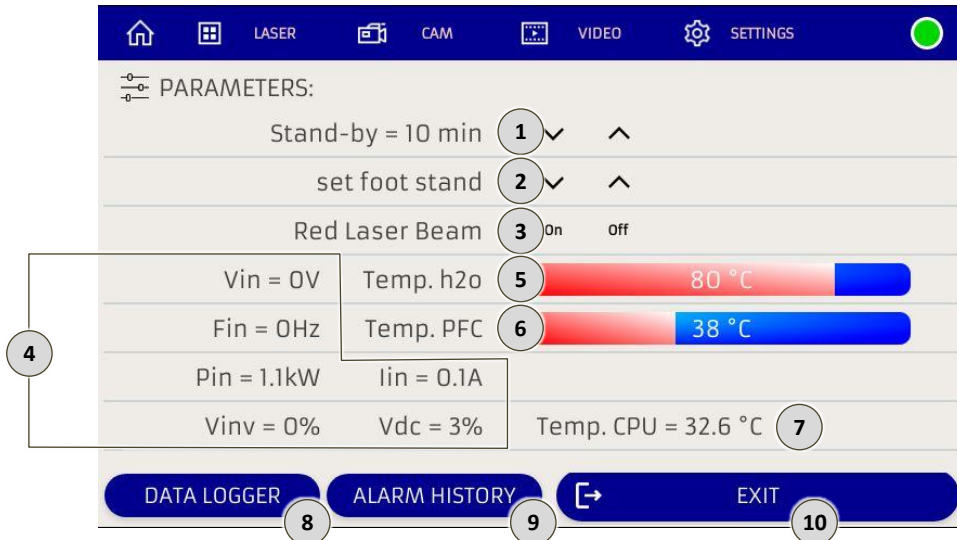

Fig. 8-11 – Parameters page

- 1 This display area shows the idle time, in minutes, after which – unless the pedal is pressed – the machine will automatically shift into stand-by mode (the resonator shutter will activate and interrupt the laser path). Next to this area you will find the ▲ and ▼ controls. When pressed, these controls allow the operator to increase or decrease the set value.
- 2 When pressed, these control areas allow the operator to lift ▲ or lower ▼ the motorized up-down support (optional machine accessory, sold separately).
- 3 When pressed, these control areas allow the operator to turn on or turn off the class 1 laser pointer, which projects a dot (optional machine accessory, sold separately).
- 4 View-only area displaying the instantaneous values of the electrical welding characteristics.
- 5 View-only area displaying the temperature (°C) of the cooling liquid.
- 6 View-only area displaying the temperature (°C) of the PFC source.
- 7 View-only area displaying the temperature (°C) of the welding machine CPU.
- 8 When pressed, this control area allows the operator to display the log file.
- 9 When pressed, this control area allows the operator to view the history of all warnings flagged by the machine. For a list of warning messages, please refer to paragraph 8.5.7.2.
- 10 When pressed, this control area allows the operator to return to the “Settings” page (paragraph 8.5.7

### 8.5.7.2 Warning messages

The following table (Tab. 8-4) lists the warnings flagged by the machine. For each warning, the table includes the warning text displayed on the operator panel, the possible cause for the warning and, when applicable, the operations required to restore the machine to normal conditions.

If you need to request an intervention by the technical support team, please refer to chapter 12 for details on how to contact Taumac S.r.l.

#	Warning message	Possible cause	Troubleshooting operations
Error 01	TEST SIMMER	The laser lamp is not turning on.	<ul style="list-style-type: none"> <li>• Check the fuse;</li> <li>• Please contact the <i>Customer Service</i>.</li> </ul>
Error 02	TEST FLUX H2O	The cooling liquid is not flowing in the cooling tubes, due to: <ol style="list-style-type: none"> <li>a) The pump not activating.</li> <li>b) Dirty or torrid water.</li> </ol>	<ul style="list-style-type: none"> <li>• Check the fuses and please contact the <i>Customer Service</i>,</li> <li>• Look through the inspection slits to check the color of the cooling liquid and if any debris residues are present on the bottom of the tank. If this is the case, replace the liquid and clean the cooling system.</li> </ul>
Error 03	TEST TEMP H2O	The cooling liquid has reached the critical temperature threshold of 55°, due to: <ol style="list-style-type: none"> <li>a) Heavy machine work cycle;</li> <li>b) Insufficient liquid in the tank;</li> <li>c) The cooling fan on the side of the machine not working;</li> <li>d) Too much dust or dirt lodged on the heat pump.</li> </ol>	<ol style="list-style-type: none"> <li>a) Wait 15 minutes, with the machine switched on, until the error message disappears; if the message does not disappear, please contact the <i>Customer Service</i>;</li> <li>b) Check from the side of the machine if there is enough liquid in the tank; if needed, top-up with distilled water;</li> <li>c) Check that the fan is working; in the event of warning message n°1, the fan should spin at a very high speed, creating a certain level of disturbance. If this is not the case, please contact the <i>Customer Service</i>;</li> <li>d) Clean all dust off the exchanger by using a vacuum cleaner through the slits. Do not open this part of the machine, unless you have first contacted and consulted with the <i>Customer Service</i>.</li> </ol>
Error 04	TEST VENT PFC	The internal power electronics thermostat has detected a high temperature due to: <ol style="list-style-type: none"> <li>a) Heavy work cycle;</li> <li>b) Dust or dirt lodged on cooling fan;</li> <li>c) Cooling fan not working.</li> </ol>	<ol style="list-style-type: none"> <li>a) Wait a few minutes for the error message to disappear and let the machine rest for approximately 20 minutes;</li> <li>b) Use a vacuum cleaner through the slits of the ventilation grids to remove dust or dirt. Do not open this part of the machine, unless you have first contacted the <i>Customer Service</i>;</li> <li>c) Please contact the <i>Customer Service</i>.</li> </ol>

**Laser Welding machine - TAUWELD 200J**

#	Warning message	Possible cause	Troubleshooting operations
	Error 05 TEST RELAY	The machine is on but does not weld: a) Power supply issues.	b) Check the connection to the electrical grid; c) Replace the electrical power cable.
	Error 06 TEST VDC	The electronics have failed to load the capacitor bank: a) The generator is broken.	Please contact the <i>Customer Service</i> .
	Error 07 MOTOR RESET KO	The motor regulating the shot diameter fails to move.	Turn the machine off and back on again. The machine will repeat all checks on the motor. If the error persists, please contact the <i>Customer Service</i> .
	Error 12 INTERLOCK OPEN!	The interlock is disconnected.	Reconnect or please contact the <i>Customer Service</i> .

Tab. 8-4 – Warning messages



### 8.5.7.3 Memory set page

The machine can store up to 100 memory indexes.

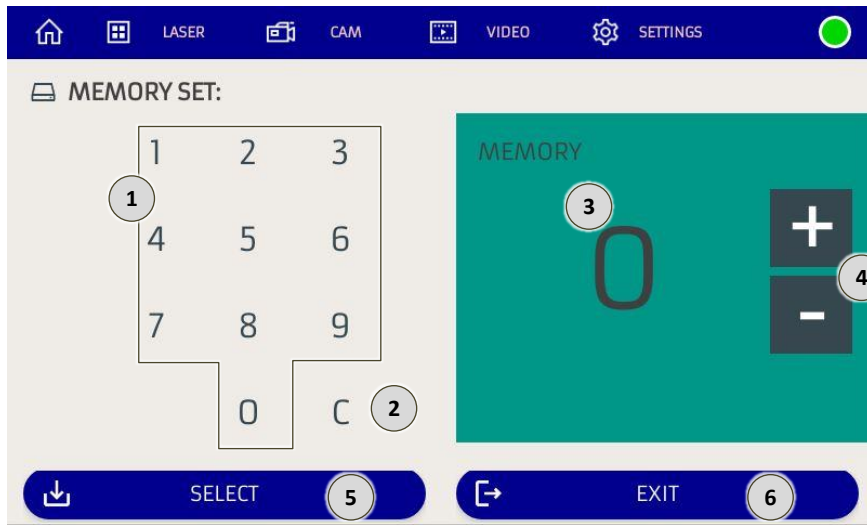

Fig. 8-12 – Memory set page

- 1 Numeric keyboard for inputting the program (memory index) number. Pressing the control areas will update the value displayed under item 3.
- 2 When pressed, this control area allows the operator to delete the latest number he/she has typed on the numeric keyboard described under item 1.
- 3 View-only area displaying the program (memory index) number the operator intends to select.
- 4 When pressed, these control areas allow the operator to increase (+) or decrease (-) the value displayed in item 3 by one unit.
- 5 When pressed, this control area allows the operator to “load” the laser operation parameters stored in the memory index indicated in item 3.
- 6 When pressed, this control area allows the operator to return to the “Settings” page (paragraph 8.5.7).

#### 8.5.7.4 Date/time settings page

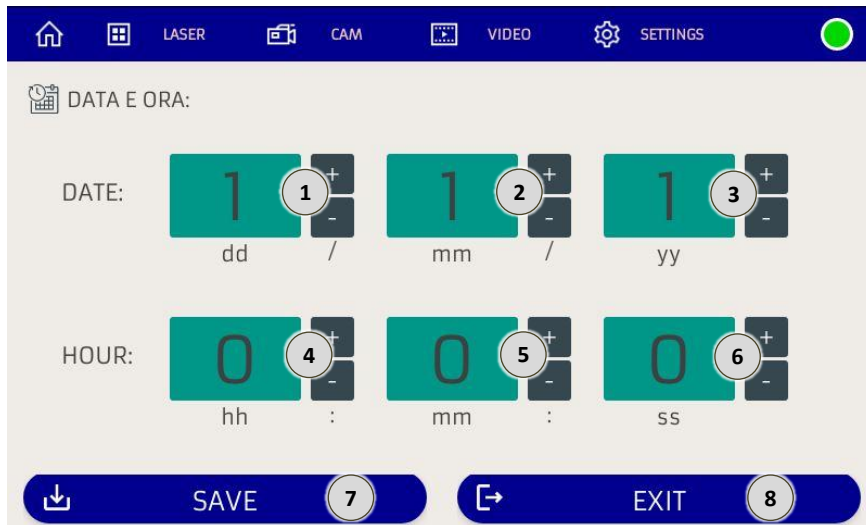

Fig. 8-13 – Date/time settings page

- 1 This display area shows the day.  
Next to this area you will find the controls that, when pressed, allow the operator to increase (+) or decrease (-) the set value by one unit.
- 2 This display area shows the month.  
Next to this area you will find the controls that, when pressed, allow the operator to increase (+) or decrease (-) the set value by one unit.
- 3 This display area shows the year (last two numbers).  
Next to this area you will find the controls that, when pressed, allow the operator to increase (+) or decrease (-) the set value by one unit.
- 4 This display area shows the hour.  
Next to this area you will find the controls that, when pressed, allow the operator to increase (+) or decrease (-) the set value by one unit.
- 5 This display area shows the minutes.  
Next to this area you will find the controls that, when pressed, allow the operator to increase (+) or decrease (-) the set value by one unit.
- 6 This display area shows the seconds.  
Next to this area you will find the controls that, when pressed, allow the operator to increase (+) or decrease (-) the set value by one unit.
- 7 When pressed, this control area allows the operator to “save” the date and the time set in this page.
- 8 When pressed, this control area allows the operator to return to the “Settings” page (paragraph 8.5.7).

**8.5.7.5 Software management page**

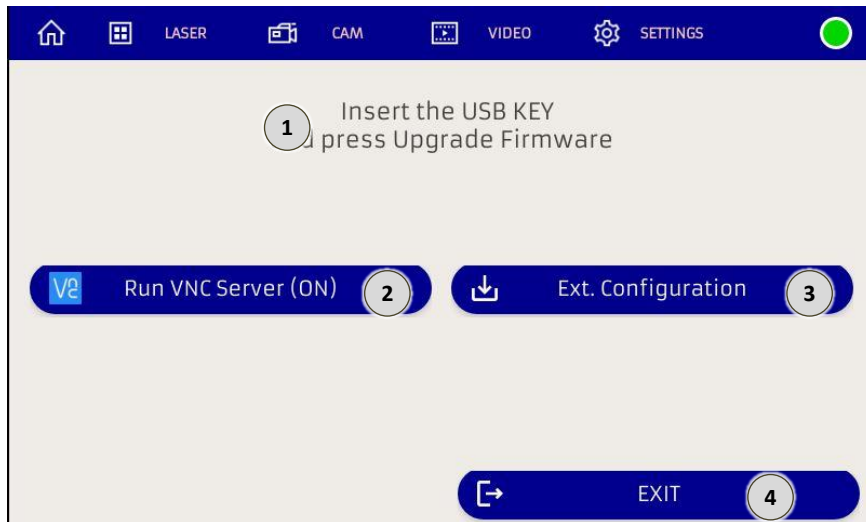

Fig. 8-14 – Software management page

- ① View-only area displaying the interface messages indicating the operations required to proceed with the update.
- ② When pressed, this control area allows the operator to start a teleassistance connection.
- ③ When pressed, this control area allows the operator to load a firmware update - concerning the graphics of the operator panel - from a USB source.
- ④ When pressed, this control area allows the operator to return to the “Settings” page (paragraph 8.5.7)

### 8.5.7.6 Network settings page

The machine can be connected to an Ethernet and/or Wi Fi network.

The RJ45 socket (Fig. 6-13) is located on the rear of the machine.



Fig. 8-15 – Network settings page (Ethernet)

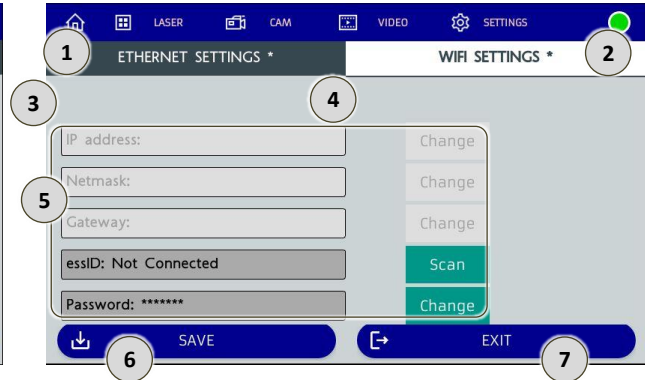

Fig. 8-16 – Network settings page (Wi Fi)

- 1 When pressed, this control area allows the operator to display the network settings for an Ethernet network.
- 2 When pressed, this control area allows the operator to display the network settings for a Wi Fi network.
- 3 When pressed, this control area allows the operator to enable/deactivate the DHCP protocol that automatically assigns the machine the various parameters needed for its operation on the network it is connected to.  
*Note: When the DHCP protocol is enabled, the settings described under item 5 cannot be edited.*
- 4 When pressed, this control area allows the operator to enable/deactivate the interface.
- 5 When pressed, these control areas allow the operator to set the various parameters needed for the machine to operate on the network it is connected to.  
*Note: Some parameters can only be edited if the DHCP protocol is deactivated.*
- 6 When pressed, this control area allows the operator to “save” the settings on this page.
- 7 When pressed, this control area allows the operator to return to the “Settings” page (paragraph 8.5.7).
- 8 When pressed, this control area allows the operator to enable/deactivate the settings as a supervisor.

## 8.6 How to stop the machine

### 8.6.1 Introduction

Please find below details on operations required to stop the machine. The operations described below are the only ones permitted by the manufacturer.

### 8.6.2 Standby

The machine will automatically suspend laser operations (the resonator shutter activates, interrupting the laser path, and the resonator is unloaded) when the control pedal is not used for a certain time frame.

The duration of the idle period causing the laser to be put in standby can be set from the “parameters” page on the operator panel (paragraph 8.5.7.1).

To start using the machine again, simply press the **START** control on the home page of the operator panel.

### 8.6.3 Normal stop





To stop the machine (for operator breaks, at the end of work shifts, for calibration operations, etc.), please follow the sequence of actions described in the following Tab. 8-5.

Symbol	Action	Feedback / notes
	Turn the ignition key leftwards, to the “LOCK” position.  Remove the key from the ignition switch and give it to the person in charge of its management.	The machine will turn the laser source off, the resonator shutter will close and the machine will check that it has closed in the expected time frame.

Tab. 8-5 – Normal stop

### 8.6.4 How to turn the machine off

To turn the machine off, please follow the sequence of operations described in the following Tab. 8-6.

Symbol	Action	Feedback / notes
	Turn the ignition key leftwards, to the “LOCK” position.	The machine will turn the laser source off, the resonator shutter will close and the machine will check that it has closed in the expected time frame.
	When the STATUS notification area on the laser operation settings page displays the “LASER LOCKED” message, turn the power switch to the “O” position.	
	Disconnect the plug from the network socket.	
	<b>Always turn the machine off by first remove the key, “OFF” state, so that the microprocessor can unload the internal capacitors bank; only turn off the electrical switch after the machine is locked.</b>	

Tab. 8-6 – How to turn the machine off

## 8.7 Troubleshooting

The following table (Tab. 8-7) lists a series of potential issues which may take place (due to incorrect use / operations with TAUWELD 200J and/or due to machinery faults) and cause:

- Inadequate processing quality (and consequently insufficient quality of the product);
- Inadequate efficiency / productivity levels;
- Hazards for the machine and/or operator.

The table lists the possible cause and solution(s) to be implemented for each issue.

If the problem cannot be solved with the solutions proposed below, please contact the Customer Service: please refer to chapter 12 for details on how to request support.

#	Issue	Solution(s)
1	The machine turns on but does not reach the START position.	<ul style="list-style-type: none"> <li>• Check the position of the safety key.</li> </ul>
2	The display shows the settings, but the laser fails to shoot.	<ul style="list-style-type: none"> <li>• Check the connection between the machine and the control pedal.</li> </ul>
3	The shutter closes the visual path in the microscope and turns dark, but there is no effect on the welded workpiece.	<ul style="list-style-type: none"> <li>• The power and time settings are too low;</li> <li>• The zoom drum is not in the correct position;</li> <li>• The positioning glass is dirty (please refer to paragraph 9.2.4).</li> </ul>
4	The lights in the welding chamber fail to turn on.	<ul style="list-style-type: none"> <li>• Check the position of the activation switch and of the calibration switch for the lights inside the welding chamber;</li> <li>• Check the fuses.</li> </ul>
5	When using the laser, the smoke generated by the welding floats upwards, towards the microscope, and clouds the operator's view.	<ul style="list-style-type: none"> <li>• The filter on the internal fan of the welding chamber is too dirty;</li> <li>• If the fan is not operating, check the fuse.</li> </ul>
6	No shield gas is released when pressing the control pedal.	<ul style="list-style-type: none"> <li>• Check on the display that the gas release countdown is activated (please refer to paragraph 8.5.3);</li> <li>• Check that the input pressure level does not exceed 2 bar;</li> <li>• Check the gas flow calibration by using the regulator inside the welding chamber (Fig. 7-7);</li> <li>• Check that no foreign object is blocking the passage of gas in the rear connection.</li> </ul>
7	No compressed air is produced when the dispenser is turned on.	<ul style="list-style-type: none"> <li>• Check that no foreign object is blocking the passage of air in the rear connection;</li> <li>• The pressure level is too low.</li> </ul>
8	The laser fails to turn on.	<ul style="list-style-type: none"> <li>• Check that the power switch of the machine is set on the "I" position;</li> <li>• Check that the emergency press-button is not pressed;</li> <li>• Check the fuses;</li> <li>• Check the connection to the electrical power network.</li> </ul>

Tab. 8-7 – Issues, causes and solutions



**OBLIGATION!:** Should you need to replace a fuse, use exclusively original spare parts of the same type as the one that needs to be replaced. Please contact Taumac S.r.l. to solve any queries.

## 9 Maintenance

### 9.1 Maintenance safety rules



**OBLIGATION!** All EXTRAORDINARY maintenance operations must be performed exclusively by qualified Taumac S.r.l. staff (please refer to paragraph 4.8) or staff authorized by this company, with the necessary technical know-how to perform these operations in conditions of maximum safety and in full compliance with currently effective regulations and laws on the subject.



**WARNING!** Failure to observe these safety instructions can cause injuries, death or damage to the machine.



**WARNING!** Every maintenance operation must be performed with the machine switched off, after having disconnected all sources of electrical power supply from it. This is the only way to make sure that no accidental starting of the machine will occur while the maintenance staff is working.



**WARNING!** Some components of the electrical equipment may still be live even after the electricity has been disconnected.



**WARNING!** When requiring the opening of cover panels, maintenance of the machine must be performed exclusively by qualified staff (please refer to paragraph 4.8) from Taumac S.r.l. or authorized by the company.



**WARNING!** If, during maintenance operations performed by the specialized Taumac S.r.l. staff, operations involving the line-of-sight laser trace are required, the work area will be considered a class IV LASER safety area. In this case, all persons within the area must wear the required protection devices (special protective glasses for the indicated wavelength (1.064 nm)), or exit the area in question. We recommend delimiting the area during maintenance and servicing operations by using fixed walls or protection curtains.

### 9.2 Ordinary maintenance

#### 9.2.1 Checking safety signs

Check the presence (in the pre-established points, please refer to paragraph 4.4), integrity and readability of all safety signs on the machine, **every six months**.

Replace any damaged labels or signs.



**WARNING!:** *The absence of safety signs can expose the worker to hazards, as he/she may not perceive the presence of any residual risks.*

### 9.2.2 Welding chamber infrared filter

The infrared filter of the welding chamber inspection window **must always be checked visually** (making sure of its functional integrity) **every time the machine is used**. If the filter is broken, the machine must not be used until the glass-filter is replaced.



**OBLIGATION!:** *Use original spare parts only.*



**WARNING!:** *The use of common types of glass or non-certified filters can cause radiation leakages that can be hazardous for the operator's eyes and skin.*

### 9.2.3 Guards

The guards must be checked **at least every 6 months**.

The following elements need to be checked:

- Check that no part of the guard is missing or damaged, especially if this diminishes its safety functions;
- Replace any worn parts (e.g. the flexible shielding);
- Check the wear levels of joints and fastening points;
- Check for any deterioration caused by corrosion, temperature variations, chemical effects.

Specifically, the segmented blind (flexible shield) **must always be checked visually** (making sure of its functional integrity) **every time the machine is used**. In the event of ruptures, missing parts, excessive curling, bending or wear of the leather segments, the machine must not be used until the blind is replaced.



**PROHIBITION!:** *Never remove, disassemble or change the casing or parts of the casing. If necessary, only specialized Taumac S.r.l. staff can access the inner parts of the machine.*



#### 9.2.4 Replacement of the special protection glass

Whenever the special protection glass is “dirty”, its performance will decrease; thus, whenever a significant concentration of metal sprays hits its surface, the glass will need to be replaced.

Periodically check the protection glass of the microscope lens, located inside the welding chamber; this special glass, which becomes non-reflective at 1064 nm, is fastened to the optical path exit by an aluminum ring.

Please follow the indications provided below to replace the special protection glass (Fig. 9-1):

- Use a 3mm hex head wrench to unscrew the two fastening screws of the support ring;
- Remove the ring from the optical unit and extract the glass;
- Clean the surface with a soft and non-abrasive cloth;
  - Do not attempt to remove any metal spray residues;



**INFORMATION!: We recommend replacing the protection glass if it is stained by a significant amount of metal sprays, given that the laser pulses may further overheat it and even cause it to crack.**

- Insert the new glass in its seat, carefully return the ring to its position and fasten the previously removed screws.

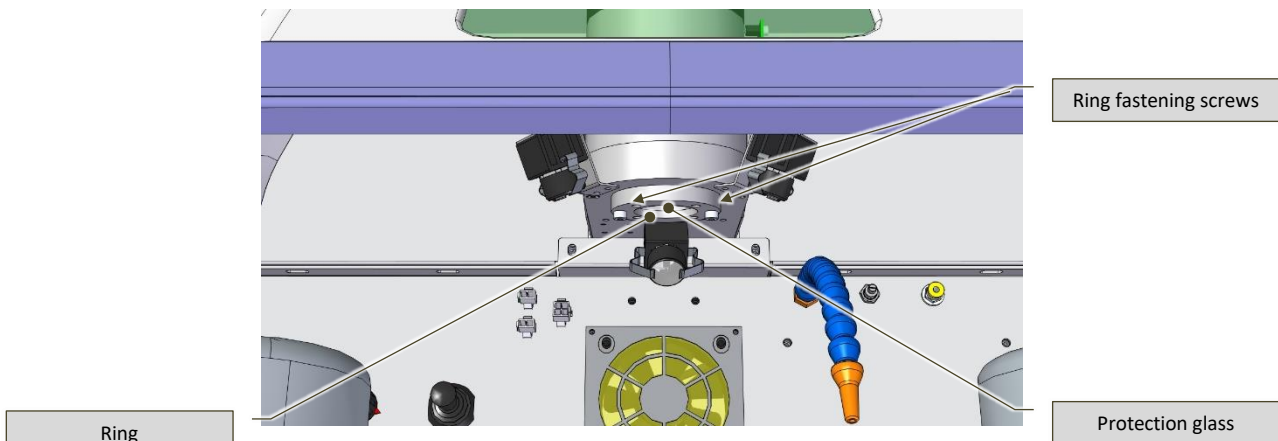

Fig. 9-1 – Replacement of the special protection glass – bottom-up view of the welding chamber



**OBLIGATION!: Use original spare parts only.**

**The use of common types of glass or non-certified filters can cause radiation leakages that can be hazardous for the operator's eyes and skin.**

### 9.2.5 How to align the reticle pointer of the binocular

The reticle pointer may sometimes not be aligned with the actual shot point. This can occur when the welding machine is moved or lifted.

Impacts with the microscope can also cause misalignments between the reticle pointer and the actual shot point. In any case, these minor optical defects can be compensated for by performing regulation of the pointer.

First of all, you will need to align the binocular (Fig. 9-2):

- Loosen the screw holding the binocular in position on its base (use the 2,5 mm hex head wrench supplied with the machine);
- Push the binocular against the side, in the opposite direction to the frontal position;
- Fasten the binocular position screw;
- Calibrate the binocular, by following the instructions provided under paragraph 7.5.1.

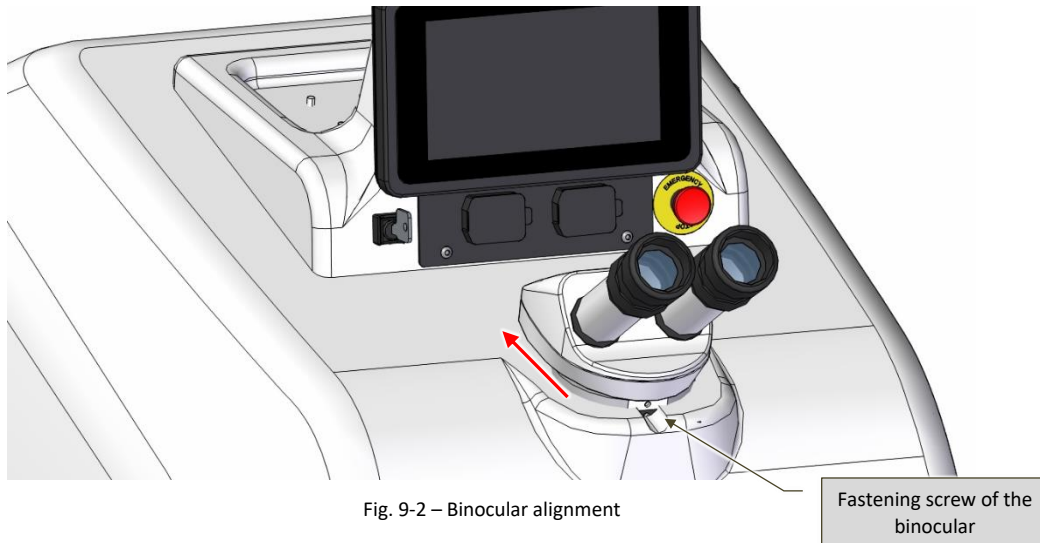
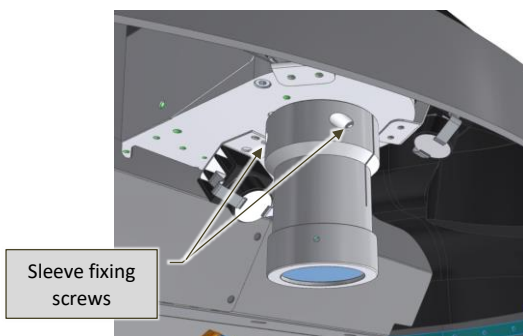

Fig. 9-2 – Binocular alignment

To check and possibly correct the alignment of the aiming reticle, follow the instructions below:

- Place a piece of sheet metal on the workpiece table in a stable way with a focused view;
- Hit the previously positioned plate with a single low-power shot;
- Deactivate the laser source;
- Loosen the two locking screws of the sleeve (Fig. 9-3) e and lower it just enough to reach the adjustment screws around the optical canal (Fig. 9-4);



Sleeve fixing screws

Fig. 9-3 – Preparation of the sleeve for the adjustment of the binocular (left side view)

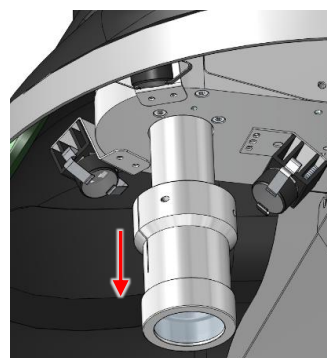

Fig. 9-4 – Preparation of the sleeve for the adjustment of the binocular (right side view)

- Look inside the microscope and, using a 3 mm hex wrench, slightly rotate the screws 1 and / or 3 present near the sleeve, until the reticle overlaps with the point where the shot hit the blade (**Errore. L'origine riferimento non è stata trovata.6**).

Progressively act on screws 1 and 3, alternating the action on one and the other, as many times as necessary to ensure that both (the aiming reticle focused on the object and the point of focus of the shot) coincide perfectly.



**INFORMATION !:** It is important to act on only one screw at a time as each of them has a distinct displacement effect:

- Screw 1 allows vertical movements, clockwise upwards;
- Screw 3 allows horizontal displacements, clockwise to the right.



**PROHIBITION !:** Screw 2 must NEVER be touched (it remains fixed), otherwise you risk compromising the entire alignment system.

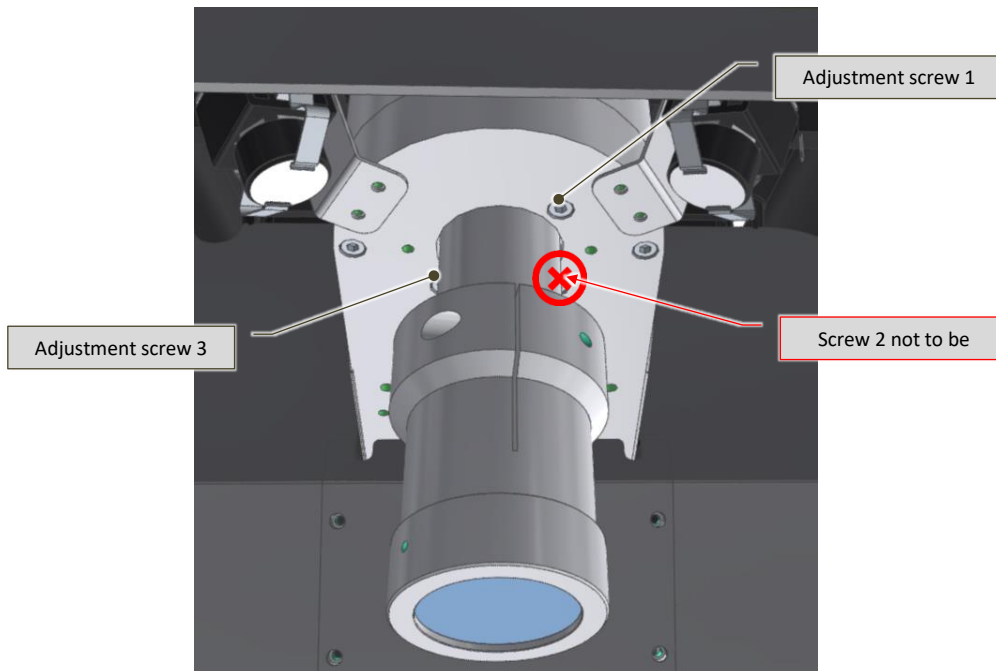

Fig. 9-5 – Adjusting the alignment of the aiming reticle

- Once the adjustment is complete, reposition the sleeve so that there is approximately 1-2 mm between the optical channel and the upper base in order to avoid touching and moving the internal prism. Tighten its two locking screws.



**ATTENTION !:** During the alignment phases pay attention to the position of the hands which could interfere with the passage of the laser beam.



**INFORMATION !:** Always approach the alignment point with small movements and keeping the test plate stable.

***Never completely unscrew the adjustment screws (1 and 3) and DO NOT touch the screw 2 (Errore. L'origine riferimento non è stata trovata.).***

### 9.2.6 How to check and replace the cooling liquid

The cooling liquid in the tank must be checked (level) **every year** and refilled if necessary, only with distilled water, and replaced **every 3 years**, in order to avoid the formation of micro-algae in the closed cooling circuit, which could decrease or impede the efficacy of the heat exchange process.



**INFORMATION!: We recommend replacing the water before the end of the hot season.**

To remove the cooling liquid from the machine:

- Connect the supplied cooling liquid top-up tube to the female connector (Fig. 7-18) on the rear of the machine;
- Place the free end of the top-up tube in a container to collect the water;
- Manually remove the black cap (Fig. 7-18) of the “overflow” tube on the upper rear of the machine;



**WARNING!: Hold the overflow tube firmly (Fig. 7-18) when removing its black cap, to ensure it does not become dislodged.**

- Let the cooling liquid flow out, until the tank is completely empty;
- Next, proceed to re-fill the cooling system, by following instructions provided under paragraph 7.4.

### 9.3 Extraordinary maintenance (support service)



**OBLIGATION!: These procedures can be performed EXCLUSIVELY by expert and qualified Taumac S.r.l. staff (or by personnel authorized by Taumac S.r.l. ).**

**To contact Taumac S.r.l. , please consult chapter 12 (Support service).**

#### 9.3.1 Safety devices checks and maintenance

The integrity and functionality of the safety devices must be checked by a qualified and expert technician (please refer to paragraph 4.8 for details on staff in charge of extraordinary maintenance) **at least every six months**.

#### 9.4 Further maintenance operations

TAUWELD 200J must undergo overhauling and extraordinary maintenance that also involves the replacement of the laser lamp and cleaning of the mirrors (**every 7 million laser pulses**); this must be performed by expert and qualified Taumac S.r.l. staff (or by personnel authorized by this same company).

To display the total number of laser shots performed by the machine, access the “Settings” page on the operator panel (paragraph 8.5.7).

## 9.5 Cleaning the machine



**WARNING!** Every cleaning operation must be performed with the machine switched off, after having disconnected all sources of electrical power supply from it. This is the only way to make sure that no accidental starting of the machine will occur while the staff in charge of cleaning it is working.

Please observe the following warnings when cleaning the machine or some of its parts:

- Do not use water or other fluids to clean electrical equipment. To remove any dust deposits, simply use a clean brush or a dry rag;
- Do not use pressurized air or water sprays to clean the machine. If necessary, use an aspirator;
- Do not clean surfaces with alcohol or solvents. Use specific detergents only;
- Do not clean the lenses and the filters with solvents or other flammable substances;
- Dispose of cleaning materials in compliance with currently effective laws on the subject. Do not disperse used materials or cleaning residues in the environment.

Periodically, you will need to remove dust accumulations and/or processing waste to avoid their dispersion in the workplace.

Frequency of cleaning operations depends on the quantity of waste on the machine. In any case, we recommend cleaning the machine at the end of the work shift **every day**.

Waste is removed manually by using a suitable industrial aspirator.

Always use a normal vacuum to clean the fans – both the cooling fans and the smoke extraction fan inside the welding chamber. This operation should be carried out periodically, based on usage.



**OBLIGATION!** Suitable personal protective equipment for the respiratory tract and the eyes must be worn during all cleaning operations.



**WARNING!** Do not use pressurized air for cleaning operations. Use an industrial aspirator.

## 9.6 Spare parts

If you need to purchase spare parts (or consumables), please contact the support service (please refer to chapter 12).

## **10 Storage conditions of the machine**

### **10.1 Temporary decommissioning**

If the machine needs to be put out of service for short periods of time, simply unplug it from the electrical socket.

### **10.2 Decommissioning for long periods of time**

If you expect to put the machine out of service for particularly long periods of time, we recommend that you first clean it thoroughly and remove all water from the cooling system (please refer to paragraph 0). Next, repeat operations listed under paragraph 10.1.

Once these operations are completed, put the machine and its accessories back in the original package.

Before reactivating the machine after a long period of disuse, the cooling liquid will need to be inserted in the machine (please refer to paragraph 7.4.1).

## 11 Disassembly of the machine

### 11.1 Disassembly of the machine

The machine must be disassembled by an operator authorized to perform these operations. In any case, you will need to remember to perform a series of mandatory operations before its demolition and after it has been put out of service.



**PROHIBITION!:** Disposal of the machine or parts of the machine via the normal solid urban waste collection system is strictly prohibited (even if sorted).



**OBLIGATION!:**

- Remove all cooling liquid from the machine, as indicated in the maintenance chapter;
- Remove any accumulators (buffer batteries, dry-cell batteries, etc.). All accumulators you remove must be disposed of in compliance with currently effective laws on the subject;
- Remove all ID labels from the machine and then proceed to destroy these and any other documents concerning the machine (manuals, diagrams, etc.).

### 11.2 General rules on disposal of industrial waste

As different rules are in force in single countries, you will need to observe requirements set in place by the laws and competent institutions within the country in question.

For member countries of the EU, the legal framework is the following:

- Directive 91/156/CEE on waste products;
- Directive 91/689/CEE on hazardous waste products;
- Directive 94/62/CE on packaging and packaging waste products.

According to currently effective legislation, the machine will classify as a special waste product once disassembled.

For extra-EU countries, you will need to check and apply the correspondent legislative requirements.

### 11.3 Waste management by companies



**WARNING!:** The following rules do not apply if the holder of the waste product is a private subject.

By waste management we intend all activities aimed at managing the entire process from the production of the waste up to its final disposal, including collection, transportation, treatment and recycling.

The European Union strategy defines a series of priorities for the question of waste management:

- Reduction of waste production via the development of clean technology, the design and commercialization of products that do not contribute to waste production and pollution, as well as technological improvements to eliminate the presence of hazardous substances in waste products;
- Prevention of waste production via a correct assessment of the environmental impact of each product during its full lifespan;
- Recovery of waste products via recycling, including recycling for energy-saving purposes.

Actual disposal solutions, such as the sending of products to landfills, can be implemented only for materials which cannot be recycled.

A thorough check of the entire production chain of the waste producer will be required for waste products deriving from production operations of any sort.

In particular, producers of **hazardous and non-hazardous special** waste products are required to:

- Codify and classify their waste products;



## Laser Welding machine - TAUWELD 200J

- Keep them in observance of instructions on temporary storage conditions;
- Manage their recovery or disposal by delivering them to **qualified entities** (disposal or recovery via third parties);
- Observe all administrative obligations.



**WARNING!:** *Regardless of the destination country, environmental laws are vast and complex (and are also in constant development); we therefore invite you to read these carefully (possibly with your consultants on the subject), in order to check all obligations and rules you will need to apply.*

**WARNING!:** *Environmental laws usually sets various types of onerous penalties in the event of failed and/or incorrect application.*

## 12 Support service

To request an intervention by our support service or to order spare parts, please cite the following data, which are also featured on the EC label on the machine:

- **MODEL** of the machine;
- **SERIAL** number;
- **YEAR** of manufacture.

Every request must be addressed to:

### **Taumac S.r.l.**

Via dell'Artigianato, 26  
Romano d'Ezzelino, 36060 (Vicenza) Italia  
info@taumac.com  
[www.taumac.com](http://www.taumac.com)

Technical support is available from Monday to Friday from 8:30 am to 12:30 am and from 2:00 pm to 6:00 pm.

## 13 Summary and index of figures

### 13.1 Summary

1	General index.....	3
2	Warranty and liability .....	4
2.1	Warranty .....	4
2.2	Conditions .....	4
2.3	Exclusions and restrictions .....	4
2.4	Reserved legal rights .....	5
2.5	Seals .....	5
3	Use of the manual.....	6
3.1.1	Definitions.....	6
3.2	Structure of the manual .....	7
3.2.1	Division of the manual .....	7
3.2.2	Illustrations and tables.....	7
3.2.3	Annexes.....	7
3.3	Units of measurement .....	7
3.3.1	Derived units.....	7
3.4	Conservation of the manual.....	8
3.4.1	How to conserve the manual.....	8
3.4.2	Where to store the manual.....	8
3.4.3	How to reproduce the manual.....	8
3.4.4	What to do in the event of loss or damage .....	8
3.4.5	What to do if ownership of the machine is transferred .....	8
3.4.6	What to do in the event of changes to the machine .....	8
4	General instructions .....	9
4.1	Working in safe conditions.....	9
4.2	Safety signs.....	9
4.3	Symbols used.....	10
4.3.1	Hazard signs .....	11
4.3.2	Prohibition signs .....	12
4.3.3	Obligation signs.....	13
4.4	General information on classification of lasers.....	14
4.4.1	Hazard potential of laser classes.....	14
4.4.2	Classification obligation .....	14
4.5	Effects of laser radiation on biological tissues .....	14
4.5.1	General information .....	14
4.5.2	Hazards to the eyes.....	16
4.5.3	Pathological effects of laser radiation .....	17

4.6	Classification and specific hazards of radiation emitted by TAUWELD 200J.....	18
4.7	Graphic signs and written warnings.....	19
4.7.1	Hazard graphic signs and written warnings.....	19
4.7.2	Obligation graphic signs and written warnings.....	20
4.7.3	Other graphic signs and written warnings.....	20
4.7.4	Position of graphic signs and written warnings.....	21
4.8	Physical and intellectual requirements of personnel.....	22
4.9	Personnel in charge of transporting the machine.....	22
4.10	Staff in charge of extraordinary maintenance (support service).....	23
4.11	Laser safety officer.....	24
4.12	Staff in charge of operating the machine.....	24
4.13	Training of staff.....	24
4.14	Incorrect use.....	24
5	Characteristics and technical data.....	25
5.1	Description of the machine.....	25
5.2	Applicable technical regulations and laws.....	25
5.3	Intended conditions of use.....	26
5.4	Residual risks.....	27
5.5	Technical data of the machine.....	29
5.5.1	Technical data.....	29
5.5.2	Noise levels.....	30
5.5.3	Vibrations.....	31
5.5.4	Levels of protection.....	31
5.6	Product characteristics.....	32
5.6.1	Technical characteristics of workable products.....	32
5.6.2	Weld materials.....	33
6	Transport and installation.....	34
6.1	Transport.....	34
6.2	Handling and removal of packaging.....	34
6.3	Manual handling of loads.....	35
6.4	Installation.....	37
6.5	Installation limits.....	37
6.6	Preparation of the installation site.....	37
6.7	Assembly.....	39
6.8	Lighting.....	40
6.9	Connection to the electrical network.....	41
6.9.1	Instructions.....	41
6.9.2	How to connect.....	41
6.9.3	Protection from electric shocks.....	42

6.10	Shield gas/compressed air connection .....	43
6.11	Further connections .....	45
6.12	Management of machine keys .....	46
7	Operation.....	47
7.1	Machine operation.....	47
7.1.1	Operating principle .....	47
7.1.2	Specific glossary .....	49
7.1.3	Machine body .....	50
7.1.4	Stereomicroscope vision system.....	51
7.1.5	Welding chamber .....	52
7.2	Control device .....	54
7.2.1	Operator interface .....	56
7.3	Safety devices.....	57
7.3.1	Emergency buttons.....	57
7.3.2	Interlock .....	58
7.3.3	Activation key .....	59
7.3.4	Resonator shutter .....	59
7.3.5	Microscope shutter .....	60
7.3.6	Microscope infrared filter .....	60
7.3.7	Welding chamber infrared filter .....	60
7.3.8	Guards.....	60
7.4	Preliminary operations.....	62
7.4.1	Insertion of the cooling liquid .....	62
7.5	Preliminary regulation operations .....	63
7.5.1	Regulation of the binocular .....	63
8	Operation instructions.....	64
8.1	Safety instructions.....	64
8.1.1	Necessary checks before starting the machine .....	64
8.1.2	Required checks and behavior after starting the machine .....	64
8.1.3	Behavior in the event of fire/incipient fire .....	64
8.1.4	Non permissible operations.....	65
8.1.5	Requirements for safe use .....	65
8.1.6	Non-evident hazards.....	65
8.2	Preparation for start-up .....	66
8.3	Tensioning .....	66
8.4	Start-up .....	67
8.4.1	Operation.....	67
8.5	Operator panel .....	69
8.5.1	Menu bar .....	70

8.5.2	“Home” page .....	71
8.5.3	“Laser” operation settings page .....	72
8.5.4	Cam page .....	74
8.5.5	“Crosshairs” page.....	75
8.5.6	“Video” page.....	76
8.5.7	Settings page.....	77
8.6	How to stop the machine .....	85
8.6.1	Introduction .....	85
8.6.2	Standby .....	85
8.6.3	Normal stop .....	85
8.6.4	How to turn the machine off .....	85
8.7	Troubleshooting .....	86
9	Maintenance.....	87
9.1	Maintenance safety rules.....	87
9.2	Ordinary maintenance .....	87
9.2.1	Checking safety signs .....	87
9.2.2	Welding chamber infrared filter .....	88
9.2.3	Guards.....	88
9.2.4	Replacement of the special protection glass .....	89
9.2.5	How to align the reticle pointer of the binocular .....	90
9.2.6	How to check and replace the cooling liquid.....	93
9.3	Extraordinary maintenance (support service).....	93
9.3.1	Safety devices checks and maintenance.....	93
9.4	Further maintenance operations .....	93
9.5	Cleaning the machine.....	94
9.6	Spare parts .....	94
10	Storage conditions of the machine.....	95
10.1	Temporary decommissioning.....	95
10.2	Decommissioning for long periods of time .....	95
11	Disassembly of the machine .....	96
11.1	Disassembly of the machine.....	96
11.2	General rules on disposal of industrial waste .....	96
11.3	Waste management by companies.....	96
12	Support service .....	98
13	Summary and index of figures .....	99
13.1	Summary .....	99
13.2	Index of figures.....	103

### 13.2 Index of figures

Fig. 3-1 - Manual ID data.....	8
Fig. 4-1 – Examples of absorption of laser radiation based on time of exposure and dimensions of the beam .....	15
Fig. 4-2 – Physiology of the human eye .....	16
Fig. 4-3 – Hazard pictogram .....	19
Fig. 4-4 – Hazard pictogram .....	19
Fig. 4-5 – Hazard pictogram .....	19
Fig. 4-6 – Explanatory label.....	19
Fig. 4-7 – Warning label .....	20
Fig. 4-8 – Obligation pictogram .....	20
Fig. 4-9 – Conformity pictogram .....	20
Fig. 4-10 - Position of graphic signs and written warnings – left side view .....	21
Fig. 4-11 - Position of CE plate, graphic signs – rear side view .....	21
Fig. 4-12 - Position of graphic signs and written warnings – right side view .....	21
Fig. 4-13 - Position of graphic signs – internal view of welding chamber .....	21
Fig. 5-1 – TAUWELD 200J (top view).....	25
Fig. 5-2 – TAUWELD 200J (bottom view) .....	25
Fig. 5-3 – Examples of products to be processed for the goldsmith sector .....	32
Fig. 6-1 - Transportation devices .....	35
Fig. 6-2 – Lifting technique .....	35
Fig. 6-3 – Handling technique .....	36
Fig. 6-4 - Handling technique .....	36
Fig. 6-5 – Ideal installation on worktable.....	38
Fig. 6-6 – View of machine support base.....	39
Fig. 6-7 – Positioning on the work surface.....	39
Fig. 6-8 - Position of control pedal connection .....	40
Fig. 6-9 – Electrical power cable connector .....	41
Fig. 6-10 – Socket (Schuko) / 2-pin plug + grounding .....	41
Fig. 6-11 – Air and gas dispensers inside the welding chamber .....	43
Fig. 6-12 – Quick connections for shield gas and compressed air supplies .....	43
Fig. 6-13 - Position of connection points for networks and external units in the TAUWELD 200J .....	45
Fig. 7-1 – TAUWELD 200J .....	47
Fig. 7-2 – Operating principle .....	48
Fig. 7-3 – Body of the machine (image without binocular/visor) .....	50
Fig. 7-4 - Binocular .....	51
Fig. 7-5 – Dioptic correction ring.....	51
Fig. 7-6 – Example of display through the vision system .....	51
Fig. 7-7 – Welding chamber (without blind) .....	52
Fig. 7-8 – Optical channel – view from welding chamber .....	53

Fig. 7-9 – Control devices: located on the left in the TAUWELD 200J model .....	54
Fig. 7-10 – Control devices inside the welding chamber .....	54
Fig. 7-11 – Control pedal.....	54
Fig. 7-12 - Operator interface .....	56
Fig. 7-13 – Emergency button (internal view of welding chamber).....	57
Fig. 7-14 – Interlock .....	58
Fig. 7-15 – Activation key (internal view of welding chamber).....	59
Fig. 7-16 – Guards .....	61
Fig. 7-17 – Guards .....	61
Fig. 7-18 – Cooling liquid top-up – rear view of the machine .....	62
Fig. 7-19 – Insertion of the cooling liquid .....	62
Fig. 7-20 – Focus / dioptric regulation .....	63
Fig. 7-21 - Eye cups .....	63
Fig. 7-22 – Binocular width .....	63
Fig. 8-23 – Menu bar.....	70
Fig. 8-24 – “Home” page.....	71
Fig. 8-25 – Language page .....	71
Fig. 8-26 – Contacts page.....	71
Fig. 8-27 – “Laser” operation settings page.....	72
Fig. 8-28 – Program name input page.....	73
Fig. 8-29 – “Cam” page .....	74
Fig. 8-30 – “Crosshairs” page.....	75
Fig. 8-67 – “Video” page .....	76
Fig. 8-32 – Settings page .....	77
Fig. 8-33 – Parameters page .....	78
Fig. 8-34 – Memory set page .....	81
Fig. 8-35 – Date/time settings page.....	82
Fig. 8-36 – Software management page .....	83
Fig. 8-37 – Network settings page (Ethernet) .....	84
Fig. 8-38 – Network settings page (Wi Fi) .....	84
Fig. 9-1 – Replacement of the special protection glass – bottom-up view of the welding chamber .....	89
Fig. 9-2 – Binocular alignment .....	90
Fig. 9-4 – Preparation of the sleeve for the adjustment of the binocular (left side view).....	90
Fig. 9-5 – Preparation of the sleeve for the adjustment of the binocular (right side view) .....	90
Fig. 9-6 – Adjusting the alignment of the aiming reticle.....	91



**A1 Copy of EC Declaration of conformity**



**La sottoscritta ditta:**  
The undersigned company:  
Die Unterzeichnerfirma:  
L'entreprise soussignée:  
La empresa abajo firmante:

**Dichiara sotto la propria responsabilità che la MACCHINA nuova:**  
Declares, under its own responsibility, that the new MACHINE:  
Erklärt auf eigene Verantwortung, dass die neue MASCHINE:  
Déclare sous sa propre responsabilité que la nouvelle MACHINE:  
Declara bajo su responsabilidad que la MÁQUINA es nueva:

**Descritta in appresso:**  
Described below:  
Nebenstehende Beschreibung:  
Décrite ci-après:  
Se describe a continuación:

**È conforme alle seguenti Direttive Comunitarie:**  
Is compliant with the following Community Directives:  
Den folgenden EG-Richtlinien entspricht:  
Conforme aux directives communautaires suivantes:  
Cumple con las siguientes Directivas Comunitarias:

**Soddisfa gli obiettivi di sicurezza indicati dalla Direttiva bassa tensione (2014/35/UE).**  
It meets the safety objectives given in the Low Voltage Directive (2014/35/EU).  
Die von der Niederspannungsrichtlinie (2014/325/EU) angegebenen Sicherheitsziele erfüllt.  
Répond aux objectifs de sécurité de la directive basse tension (2014/35/UE).  
Cumple los objetivos de seguridad especificados por la Directiva de Baja Tensión (2014/35/UE).

**Soddisfa, ove pertinenti, i requisiti delle seguenti Norme Armonizzate:**  
Satisfies, when pertinent, the requisites set by the following harmonized rules:  
Die Anforderungen der folgenden harmonisierten Richtlinien, sofern relevant, erfüllt.  
Satisfait, le cas échéant, aux exigences des normes harmonisées suivantes:  
Cumple, cuando es pertinente, los requisitos de las siguientes Normas Armonizadas:

**Costituzione del fascicolo tecnico:**  
Constitution of the technical file:  
Verfassung der technischen Unterlagen:  
Constitution du dossier technique:  
Creación del expediente técnico:

**Nome:**  
Name: - Name: - Nom: - Nombre:

**Luogo e data:**  
Place & date: - Ort und Datum: - Lieu et date: - Lugar y fecha:

**Dichiarazione di conformità - Allegato II A - 2006/42/CE**

Declaration of conformity - Annex II A - 2006/42/EC  
Konformitätserklärung - Anhang II A - 2006/42/EG  
Déclaration de conformité - Annexe II A - 2006/42/CE  
Declaración de Conformidad - Anexo II A - 2006/42/CE



**TAUMAC S.r.l.**

Via dell'Artigianato, 26 Romano d'Ezzelino, 36060 (Vicenza) Italia

**Modello:**  
Model: - Modell: - Modèle: - Modelo:

**Tipo:**  
Type: - Typ: - Type: - Tipo:

**Matricola/e:**  
Serial /s n: - Serial n: - Matricule/s:

**Anno di fabbricazione:**  
Year of manufacture: - Baujahr: - Année de fabrication:

**TAUWELD 200J**

**Saldatrice laser**  
Laser welding machine - Laser-Schweißgerät - Soudeuse laser - Máquina de soldadura por láser

**2022**

Saldatrice per manufatti in materiale metallico, che utilizza la radiazione elettromagnetica laser come sorgente di energia per riscaldare i metalli fino a portare gli stessi alla temperatura di fusione.  
Welding machine for artefacts made of metal materials, using electromagnetic laser radiation as an energy source for heating metals to melting temperature.  
Schweißgerät für Werkstücke aus Metallmaterial, das die elektromagnetische Laserstrahlung als Energiequelle zum Erhitzen der Metalle bis zum Erreichen ihrer Schmelztemperatur verwendet.  
Machine à souder les produits manufacturés en métal, qui utilise le rayonnement électromagnétique laser comme source d'énergie pour chauffer les métaux jusqu'à ce qu'ils atteignent la température de fusion.  
Máquina de soldar para trabajos en material metálico, que utiliza la radiación electromagnética del láser como fuente de energía para calentar los metales hasta alcanzar la temperatura de fusión.

**Direttiva Macchine**

Machinery Directive - Maschinenrichtlinie - Directive Machines - Directive Compatibilité électromagnétique - Directiva «Máquinas»  
2006/42/CE - 2006/42/EC (ex 98/37/CEE - 89/392/CEE - 91/368/CEE - 93/44/CEE - 93/68/CEE) (ehemals 98/37/EWG - 89/392/EWG - 91/368/EWG - 93/44/EWG - 93/68/EWG)

**Direttiva Compatibilità Elettromagnetica**

Electromagnetic Compatibility Directive - Richtlinie für elektromagnetische Verträglichkeit - Directive Compatibilité électromagnétique - Directiva sobre la compatibilidad electromagnética  
2014/30/UE - 2014/30/EU (ex 89/336/CEE) (ehemals 89/336/EWG)

Tuttavia, come previsto dal paragrafo §63 della Linea Guida all'applicazione della direttiva "macchine" 2006/42/CE, redatta dalla Commissione Europea imprese e industria, la presente Dichiarazione CE di conformità NON fa riferimento alla Direttiva bassa tensione.  
However, as indicated in paragraph §63 of the Guidelines on how to apply the Machinery Directive 2006/42/EC, written by the European Commission for business and industry, this EC Declaration of Conformity DOES NOT refer to the Low Voltage Directive.  
Wie vom Abschnitt § 63 der von der europäischen Kommission für Unternehmen und Industrie verfassten Leitlinien zur Anwendung der Maschinenrichtlinie 2006/42/EG vorgesehen, nimmt die vorliegende CE-Erklärung jedoch NICHT auf die Niederspannungsrichtlinie Bezug.  
Cependant, comme prévu par le paragraphe §63 des Lignes Directrices pour l'application de la directive «Machines» 2006/42/CE, rédigée par la Commission Européenne pour les entreprises et l'industrie, la présente déclaration de conformité CE NE fait PAS référence à la Directive Basse Tension.  
Sin embargo, tal y como establece el apartado §63 de la Directriz para la aplicación de la directiva «Máquinas» 2006/42/CE, elaborada por la Comisión Europea para Empresas e Industrias, esta Declaración de Conformidad CE NO hace referencia a la Directiva de Baja Tensión.

**EN ISO 12100 – EN 60204-1 – CEI 76-11 – EN 60825-1 – EN 61000-6-2 – EN 61000-6-4 – EN 61000-3-2 – EN 61000-3-3**

**Responsabile:**  
Technical File Manager: - Verantwortlicher: - Responsable: - Responsable:

**Luogo di conservazione:**  
Storage: - Aufbewahrungsort: - Lieu de conservation: - Lugar de almacenamiento:

Via dell'Artigianato, 26 Romano d'Ezzelino, 36060 (Vicenza) Italia

**Posizione:**  
Position: - Stellung: - Position: - Posición:

**Quality Manager**

**Firma:**  
Signature: - Unterschrift: - Signature: - Firma:

Romano d'Ezzelino, Italia

**A2 Delivery record for the safety keys of the machine**

stipulated upon delivering the “Laser welding machine” identified by the following characteristics:

Model: TAUWELD 200J

Serial number:

Year of manufacture:

The individual in charge of use and maintenance of the machine, Mr./Mrs. \_\_\_\_\_ of the Company \_\_\_\_\_, which has purchased the machine for its use, declares he/she has received:

- the full set of keys (interlock connector and activation key) needed to run the machine, as described in the user and maintenance instructions.

Date:

Stamps and signatures:

*The Manufacturer*

*The individual in charge of the machine for the Company*

## Laser Welding machine - TAUWELD 200J





