

SR Motor Series 115v and 230v Parts Price List

**All Warranty
SR Motor repairs
must be done at
the factory**

NOTE:

1 The Front and Rear Armature Ball Bearings (2) are fastened to the motor housings with Loctite 587 adhesive or equivalent.

2 The Motor Brush Tubes are fastened to the Front Housing with Araldite 2012 (AW210/HW 2934) two component epoxy adhesive or equivalent.

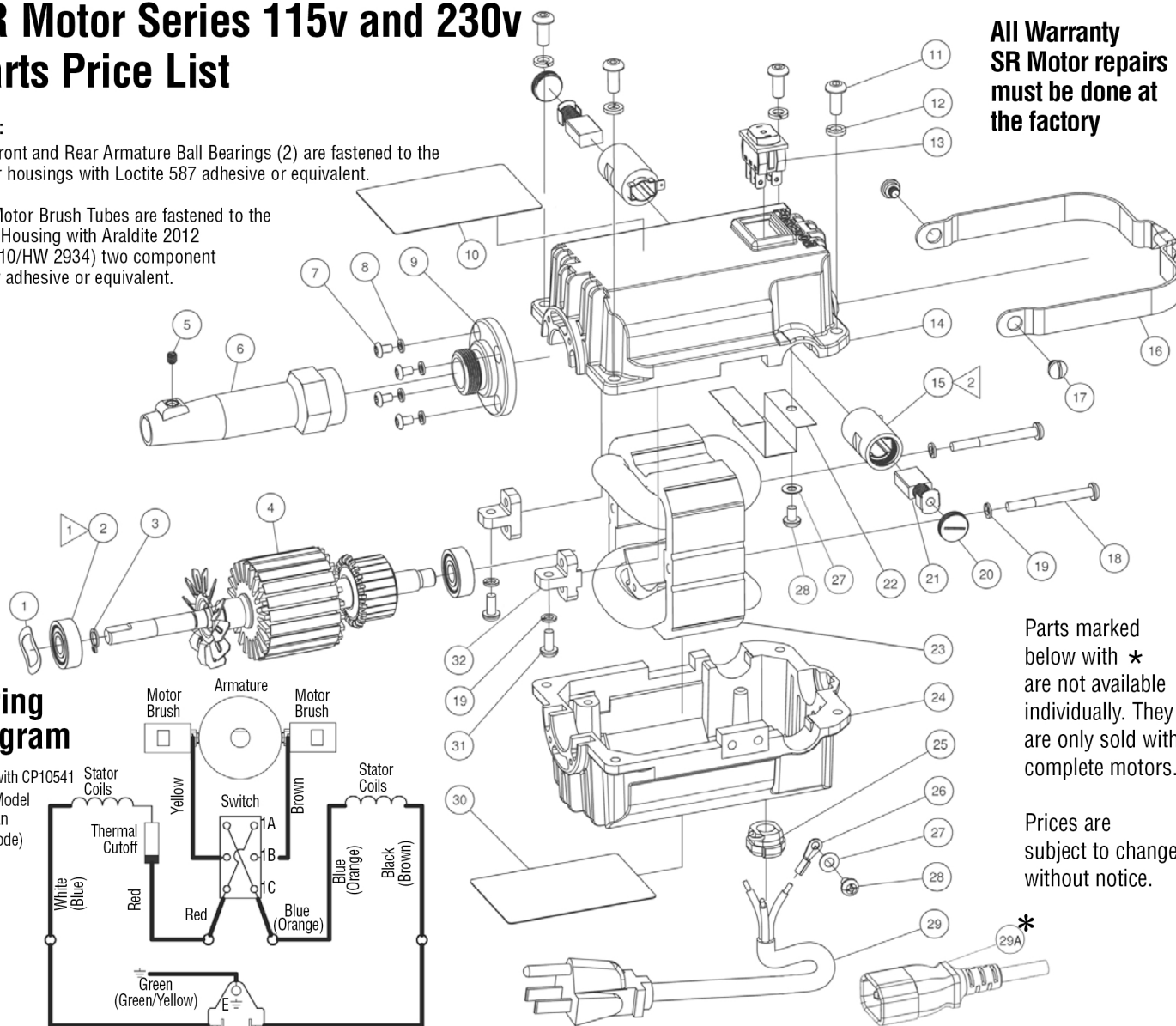

Wiring Diagram

Shown with CP10541 (230V Model European Color Code)

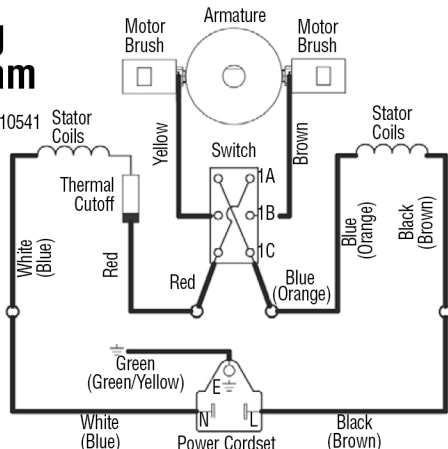

Parts marked below with * are not available individually. They are only sold with complete motors.

Prices are subject to change without notice.

Item	Part No.	Description	Qty
1	UA810	Washer, Wavy Spring, Ø21mm x Ø14.5mm x 2.5mm x 0.2 Thick	1
2	HP61	Ball Bearing, Ø22mm x Ø8mm 7mm	2
3	UA812	External Retaining Ring, Ø8mm Shaft	1
4	MP135	115V Armature Assembly, (Includes 2 Ball Bearings)	1
	MP136	230V Armature Assembly, (Includes 2 Ball Bearings)	
5	UA113	Set Screw, 8-32 x 5/16, Slotted Headless, Cup Point	1
6	UA111P	Motor Connector	1
7	UA814	Screw, M3.5 x 0.6 x 7.8mm, Cross Recessed Pan Head	4
8	UA816	Spring Lock Washer, M3.5, Type B	4
9	MP138	Hub	1
10	*	Nameplate	1
11	UA818	Cap Screw, M5 x 0.75 x 12mm, Hexagon Socket Button Head	4
12	UA819	Spring Lock Washer, M5, Type B	4
13	MP131	Switch, Three Position	1
14	*	Housing, Front	1
15	MP134	Brush Tube Assembly	2
16	UA1059	Motor Hanger	1

Item	Part No.	Description	Qty
17	UA106	Motor Hanger Screw	2
18	UA820	Screw, M4 x 0.7 x 40mm, Cross Recessed Pan Head	2
19	UA822	Spring Lock Washer, M4, Type B	4
20	MP133	Cap, Brush Tube	2
21	MP132P	Brush, Motor, (Pair)	1
22	*	Insulation Cover, Switch	1
23	*	Field	1
24	*	Housing, Rear	1
25	CP10003-3	Strain Relief, Cordset	1
26	UA824	Ring Terminal Ø4.2mm	1
27	UA825	Washer Plain, M4	2
28	UA826	Screw, M4 x 0.7 x 6mm, Cross Recessed Pan Head	2
29	CP10541	110V Cordset, male	1
29A	CP10560	230V Cordset, male *	1
30	*	Label, Specification	1
31	UA828	Screw, M4 x 0.7 x 12mm, Cross Recessed Pan Head	2
32	*	Bracket	2

FOREDOM®

Foredom Electric Company 16 Stony Hill Rd., Bethel, CT 06801

Tel: 203-792-8622 • Fax: 203-796-7861 • www.foredom.net

Form 1168 n 3/18

Complete Motor Part No. (Not including Motor Connector UA111P or Hanger UA1059)

SR 115V MP94-120

SR 230V MP94-122

* for motors produced after May, 2006.