ASSEMBLY INSTRU



ASSEMBLY INSTRUCTION

ASSEMBLY TIPS:

- 1.Remove hardware from box and sort by size.
- 2.Please check to see that all hardware and parts are present prior to start of assembly.
- 3.Please follow attached instructions in the same sequence as numbered to assure fast & easy assembly.





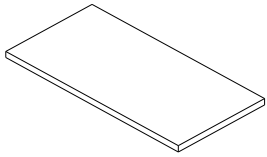
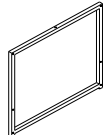
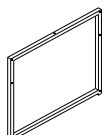
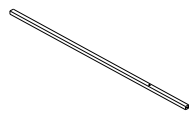
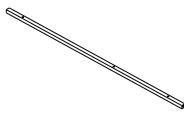
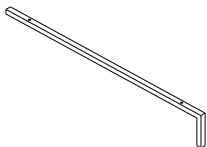
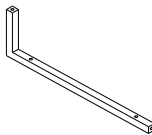
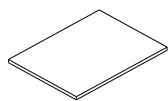
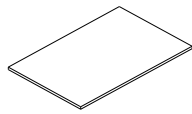

Warning!!

- 1.Don't attempt to repair or modify parts that are broken or defective.Please contact the store immediately.
- 2.This product is for home use only and not intended for commercial establishment.

PARTS IDENTIFICATION

| | |
|--|--|
| <p>A TOP</p>  <p>1PC</p> | <p>B LEFT FRAME</p>  <p>1PC</p> |
| <p>C RIGHT FRAME</p>  <p>1PC</p> | <p>D BOTTOM CROSSBAR</p>  <p>2PCS</p> |
| <p>E TOP CROSSBAR</p>  <p>2PCS</p> | <p>F LARGE CROSSBAR</p>  <p>2PCS</p> |
| <p>G SMALL CROSSBAR</p>  <p>2PCS</p> | <p>H SMALL SHELF PANEL</p>  <p>1PC</p> |
| <p>I LARGE SHELF PANEL</p>  <p>1PC</p> | |

HARDWARE PACKAGE

| Z | DESCRIPTION | FIGURE | Q'TY |
|---|--------------|---|-------|
| 1 | LONG BOLT |  | 16PCS |
| 2 | SHORT BOLT |  | 14PCS |
| 3 | CAP |  | 4PCS |
| 4 | ALLEN WRENCH |  | 1PC |

STEP 1

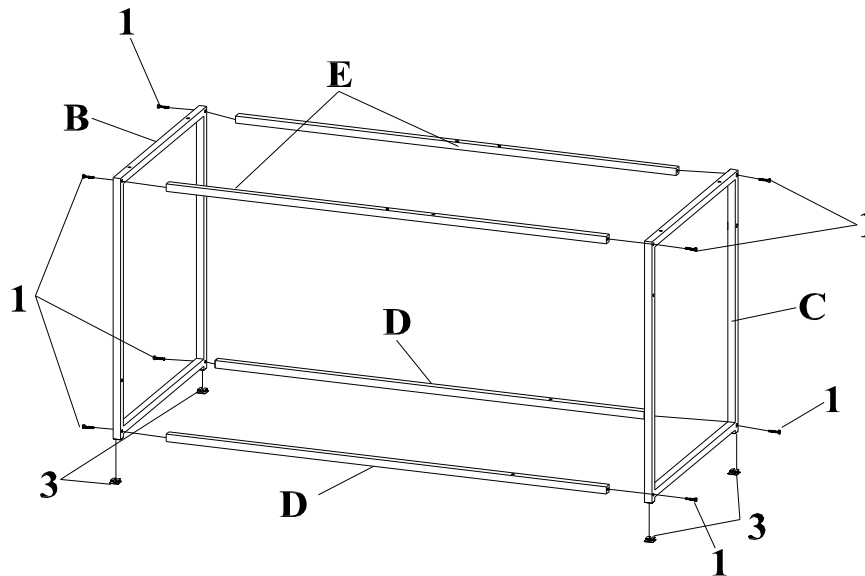

You will need one people for this installation. And will take about thirty-five minutes.

STEP 1 :

1. Insert Cap (3) into the hole at Left/Right Frame (B,C).
2. Attach Top/Bottom Crossbar (E,D) to Left/Right Frame (B,C) using Long Bolt (1) as shown.

STEP 2

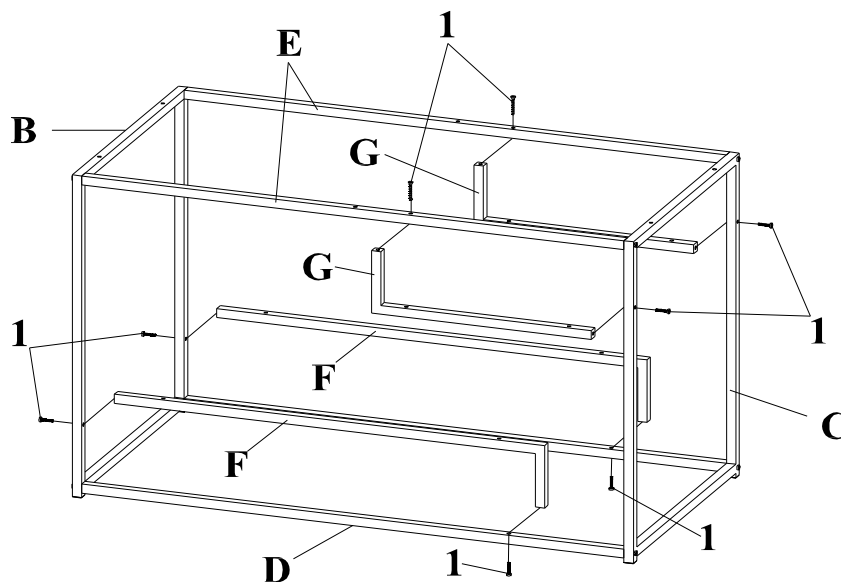

STEP 2 :

1. Attach Small Crossbar (G) to Right Frame (C) and Top Crossbar (E) by using Long Bolt (1) tighten with allen wrench.
2. Attach Large Crossbar (F) to Left Frame (B) and Bottom Crossbar (D) by using Long Bolt (1) tighten with allen wrench.

STEP 3

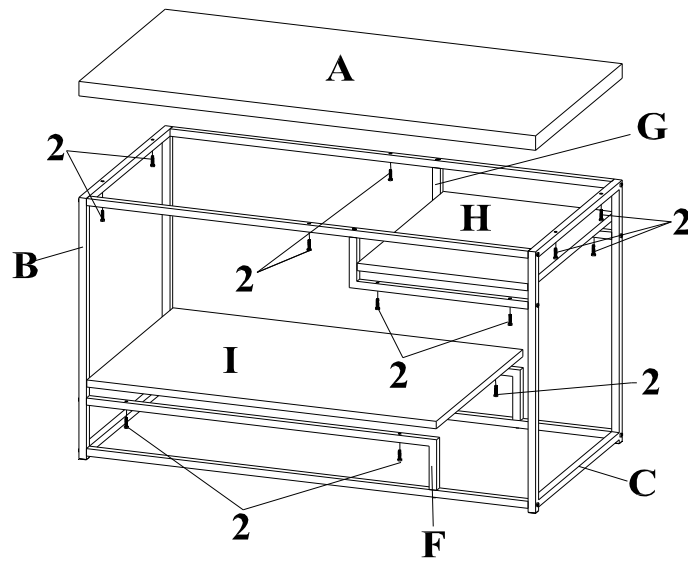

STEP 3 :

1. Place the Top (A) to Left/Right Frame (B,C) by using Short Bolt (2) tighten with allen wrench.
2. Place the Small Shelf Panel (H) to Small Crossbar (G) by using Short Bolt (2) tighten with allen wrench.
3. Place the Large Shelf Panel (I) to Large Crossbar (F) by using Short Bolt (2) tighten with allen wrench.

FINISH

