

COASTER® **460244N (B1 - B3)**
FINE FURNITURE **TWIN/TWIN BUNK BED**

ASSEMBLY INSTRUCTIONS
COASTER FINE FURNITURE



www.coastercompany.com

ITEM : 460244N (B1 - B3)

ASSEMBLY INSTRUCTIONS

ASSEMBLY TIPS:

1. Remove hardware from box and sort by size.
2. Please check to see that all hardware and parts are present prior to start of assembly.
3. Please follow attached instructions in the same sequence as numbered to assure fast & easy assembly.



Warning!

1. Don't attempt to repair or modify parts that are broken or defective. Please contact the store immediately.
2. This product is for home use only and not intended for commercial establishments.



ASSEMBLY TIME

30 MINUTES

PARTS IDENTIFICATION

B1 (BOX 1)

	PART NAME	FIGURE	QTY
A	RIGHT UPPER BED END		1 PC
B	LEFT UPPER BED END		1 PC
C	LOWER BED END		2 PCS

B2 (BOX 2)

	PART NAME	FIGURE	QTY
D	UPPER BED BACK BED RAIL (WITH 2 HOLES)		1 PC
E	UPPER BED FRONT BED RAIL(WITH 3 HOLES)		1 PC
F	LOWER BED FRONT BED RAIL(WITH 2 HOLES)		1 PC
G	LOWER BED BACK BED RAIL		1 PC
H	BACK GUARDRAIL		2 PCS
I	FRONT GUARDRAIL		2 PCS
JF	LEFT LADDER STILE		1 PC
KF	RIGHT LADDER STILE		1 PC

PARTS IDENTIFICATION

B2 (BOX 2)

	PART NAME	FIGURE	QTY
LF	LADDER STEP		3 PCS
M	FLAT GUARDRAIL SUPPORT		3 PCS

B3 (BOX 3)

	PART NAME	FIGURE	QTY
N	ROLL SLAT (14PCS/SET)		2 SETS

HARDWARE IDENTIFICATION

Z-B2 (BOX 2) - HARDWARE PACK IS LOCATED IN 460244N (B2).

	HARDWARE NAME	FIGURE	QTY
1	LONG BOLT (1/4 x 70 x 13mm - RBW)		22 PCS
2	BARREL NUT (1/4 x 13mm - RBW)		22 PCS
3	WOOD DOWEL (10 x 40mm)		8 PCS
4	SHORT BOLT (1/4 x 35 x 13mm - RBW)		24 PCS
5	FLAT HEAD SCREW (4 x 35mm - RBW)		16 PCS
6	METAL DOWEL (12 x 125mm - RBW)		4 PCS
7	ALLEN WRENCH (M4 - RBW)		1 PC

NOTE: PHILLIPS HEAD SCREW DRIVER IS REQUIRED IN THE ASSEMBLY PROCESS HOWEVER MANUFACTURER DOES NOT PROVIDE THIS ITEM.

LOWER BED END

STEP 1

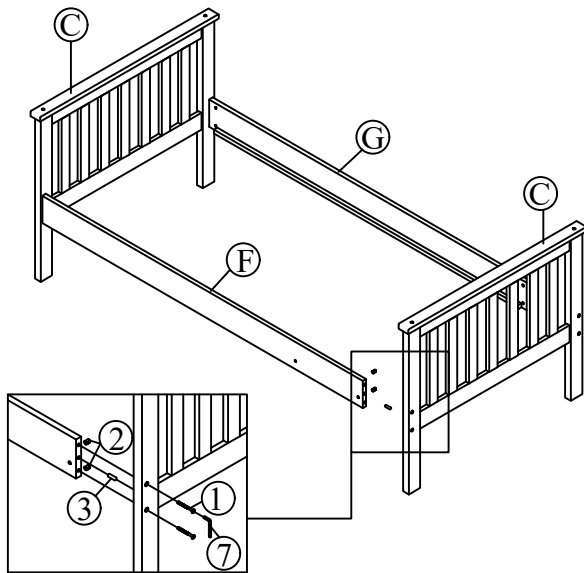

UPPER BED END

STEP 2

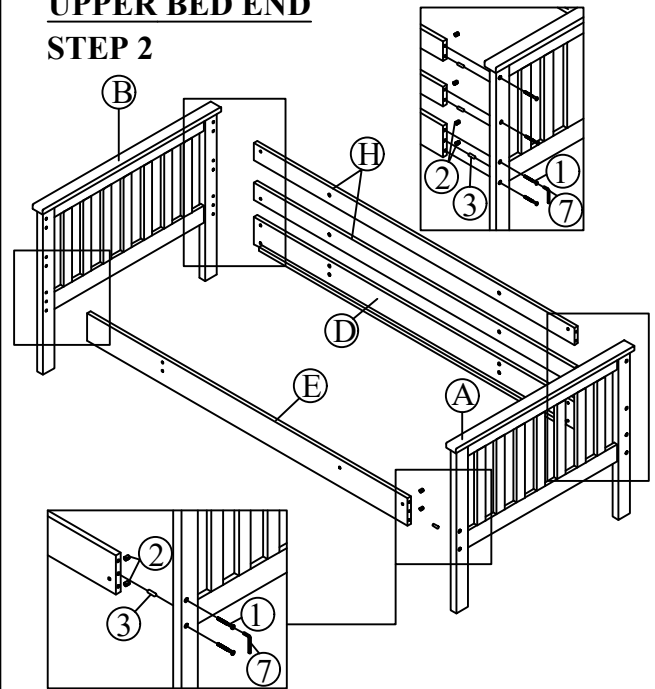

STEP 3

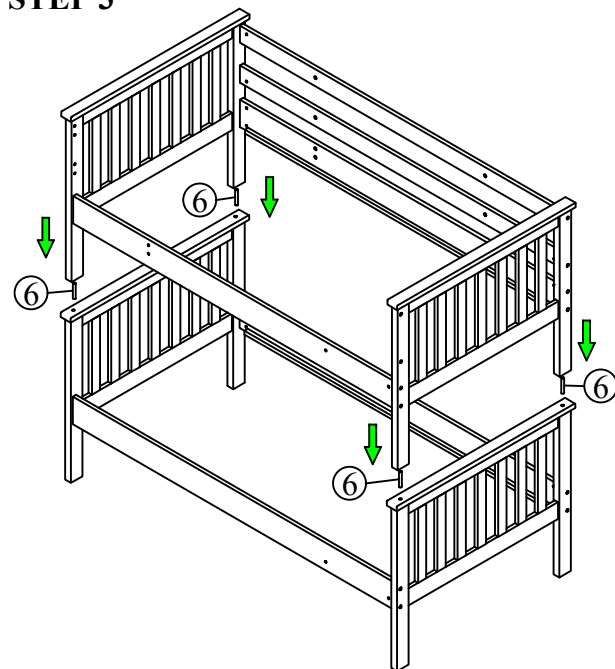

STEP 4

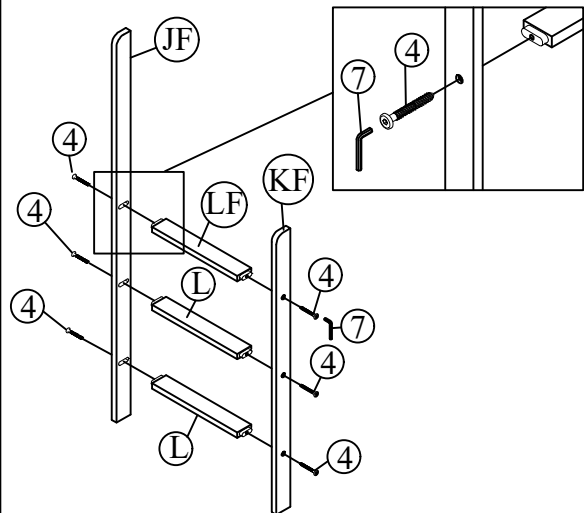

STEP 5

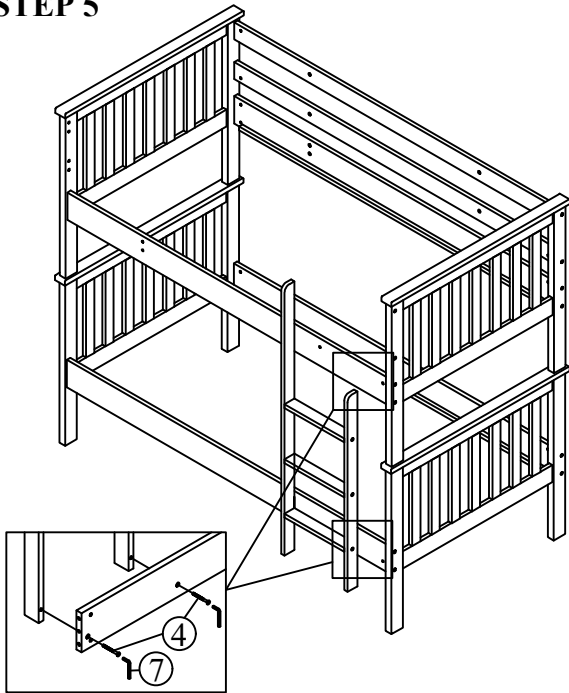

STEP 6

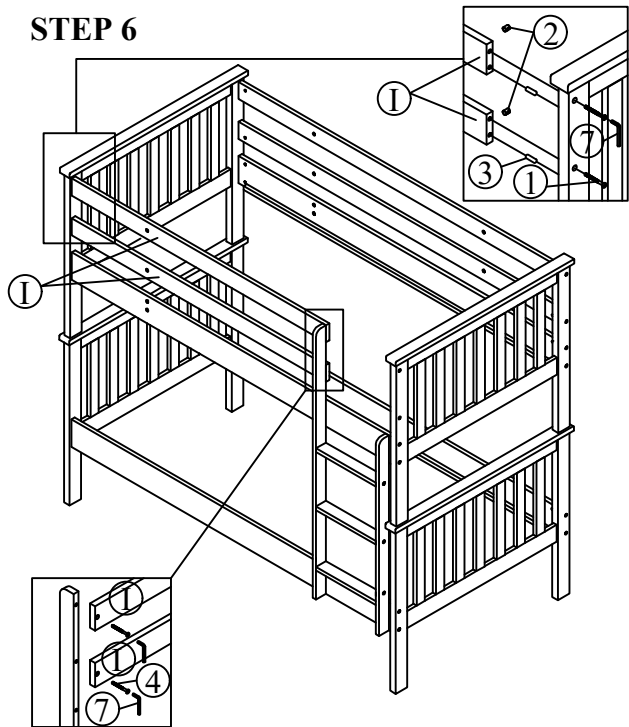

STEP 7

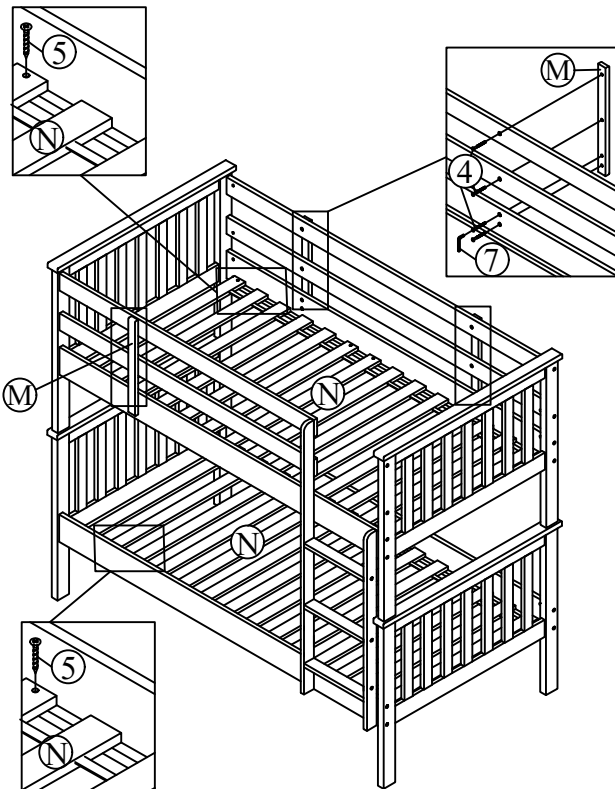

STEP 8

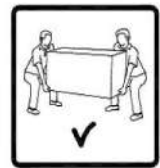
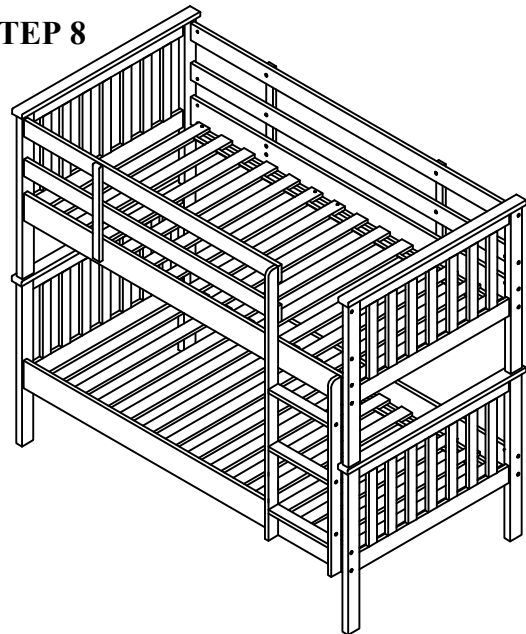

SIZE OF MATTRESS

The length and width of the bunk mattress are as follow:

	<u>Length</u>	<u>Width</u>	<u>Thickness</u>
Upper bunk	74" - 75"	37 1/2"- 38 1/2"	6" Maximum
Lower bunk	74" - 75"	37 1/2"-38 1/2"	6" Maximum

Ensure thickness of mattress does not exceed 6” and there must be at least 5” from mattress sleeping surface to top edge of guardrail.



SAFETY WARNING



1. Follow the information on the warnings appearing on the upper bunk end structure and on the carton. Do not remove the warning label from bed.
 2. Always use the recommended size mattress or mattress support or both to help prevent the likelihood of entrapment or falls.
 3. Surface of mattress must be at least 5 in. (127 mm) below the upper edge of guardrails.
 4. Do not allow children under 6 years of age to use the upper bunk.
 5. Prohibit more than one person on upper bunk.
 6. Periodically check and ensure that the guardrail, ladder, and other components are in their proper position, free from damage, and that all connectors are tight.
 7. Do not allow horseplay on or under the bed and prohibit jumping on the bed.
 8. Always use the ladder for entering and leaving the upper bunk.
 9. Do not use substitute parts. Contact the manufacturer or dealer for replacement parts.
 10. Use of a night light may provide added safety precaution for a child using upper bunk.
 11. Always use guardrails on both long sides of the upper bunk. If the bunk bed will be placed next to the wall, the guardrail that runs the full length of the bed should be placed against the wall to prevent entrapment between the bed and wall.
 12. The use of water or sleep flotation mattress is prohibited.
 13. Keep these instructions for future reference.
- STRANGULATION HAZARD:**
14. Never attach or hang items to any part of the bunk bed that are not designed for use with the bed for example, but not limited to hooks, belts, and jump ropes.

REPLACEMENT PARTS:

Replacement parts, including additional guardrails may be obtained from any COASTER Furniture Dealer.

 **WARNING****TO PREVENT SERIOUS OR FATAL INJURY**

1. When using beds as bunk beds, the ladder **MUST** be securely attached to the upper bunk rail at all times.
2. When using the beds as two (2) separate floor-standing beds, the ladder **MUST** be stored in a separate location where children cannot use the ladder in any manner.
3. **DO NOT** use, nor permit children to use, the ladder in any manner whatsoever, other than to access the top unit when used as bunk beds, and only if the ladder is securely attached to the top bunk rail, as set forth in the instructions.
4. Any misuse or unauthorized use of the ladder could result in serious or fatal injury.
5. Failure to follow the above **WARNING**, and/or failure to follow assembly instructions completely, will void any and all liability of COASTER COMPANY OF AMERICA for damages and injury to persons and property.

COASTER[®]
Fine Furniture

www.coastercompany.com | 877-COASTER (262-7837)