ASSEMBLY INSTRUCTIONS



www.coastercompa

ASSEMBLY INSTRUCTION

ASSEMBLY TIPS:

- 1.Remove hardware from box and sort by size.
- 2.Please check to see that all hardware and parts are present prior to start of assembly.
- 3.Please follow attached instructions in the same sequence as numbered to assure fast & easy assembly.





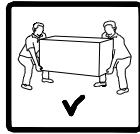

Warning!!

- 1.Don't attempt to repair or modify parts that are broken or defective. Please contact the store immediately.
- 2.This product is for home use only and not intended for commercial establishment.

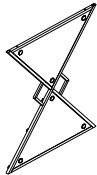
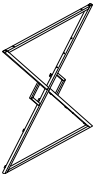
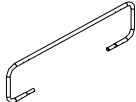

ASSEMBLY TIME PER UNIT: 60 MINUTES

PARTS IDENTIFICATION

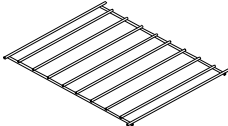
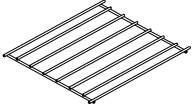
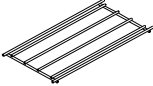
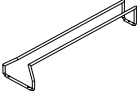
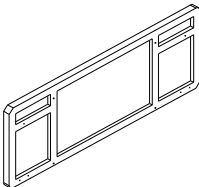
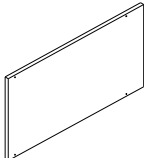
A		1PC	B		1PC
FRONT FRAME			BACK FRAME		
C		1PC	D		2PCS
FOOTREST			SHORT CROSSBAR		
E		4PCS	F		4PCS
SUPPORT LEG			BOTTLE RACK		
G		2PCS	H		1PC
LARGE SHELF			MIDDLE SHELF		
I		1PC	J		2PCS
SMALL SHELF			GLASS HOLDER		
K		1PC	L		2PCS
TOP			TOP SIDE PANEL		

M

BOTTOM SIDE PANEL

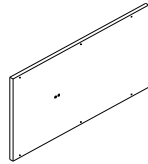

2PCS

HARDWARE PACKAGE

Z	DESCRIPTION	FIGURE	Q'TY
1	LONG BOLT		4PCS
2	LONG ALLEN BOLT		4PCS
3	SHORT ALLEN BOLT		12PCS
4	MIDDLE BOLT		4PCS
5	SHORT BOLT		12PCS
6	WINE BOLT		16PCS
7	SCREW		26PCS
8	LARGE LEVELER		4PCS
9	SMALL LEVELER		4PCS
10	ALLEN WRENCH		1PC

STEP 1

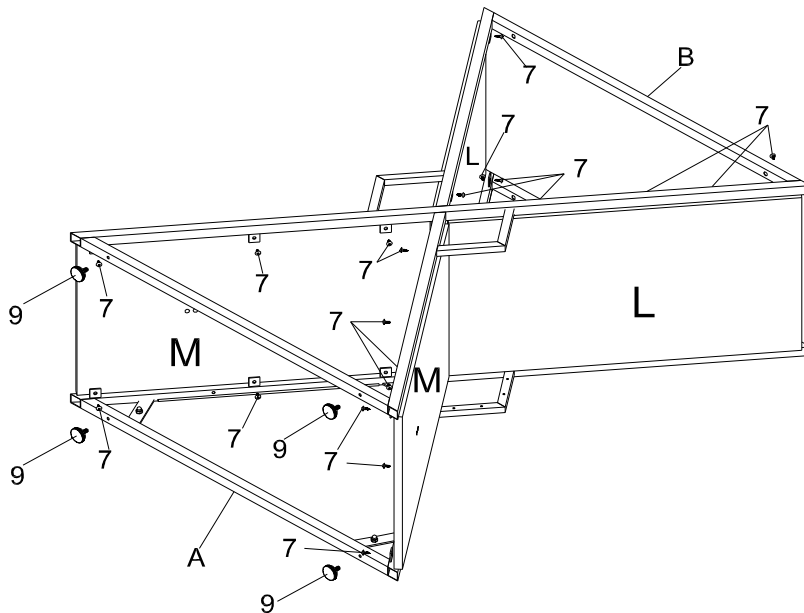

STEP 2

Same as the other side, to use #6 8pcs to assemble.

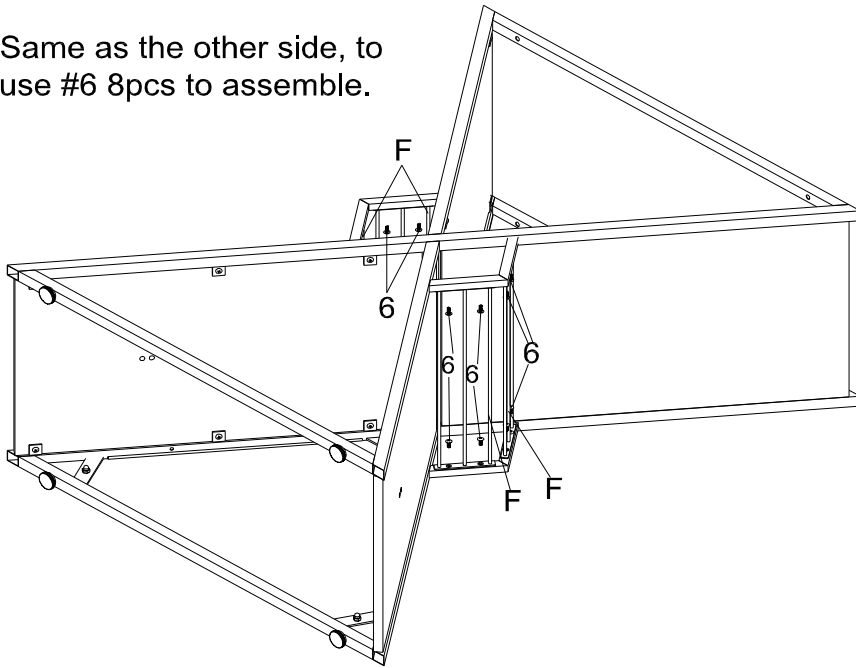

STEP 3

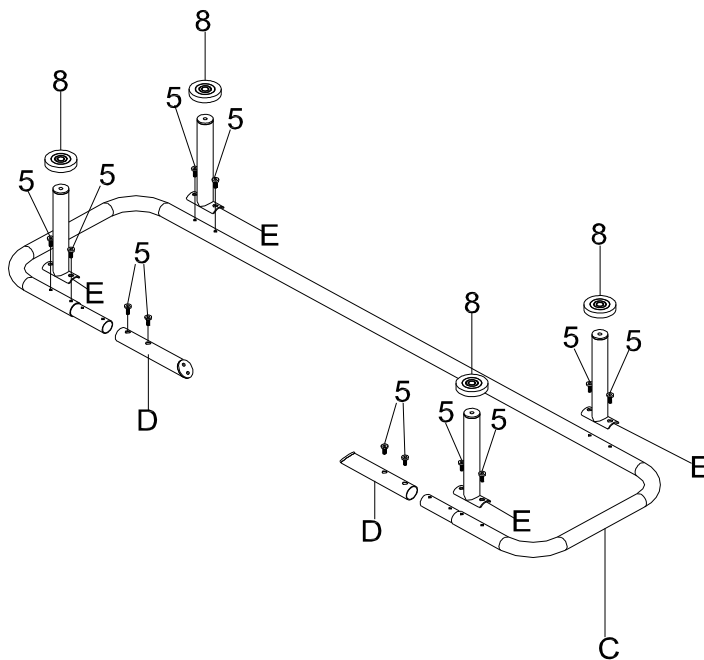

STEP 4

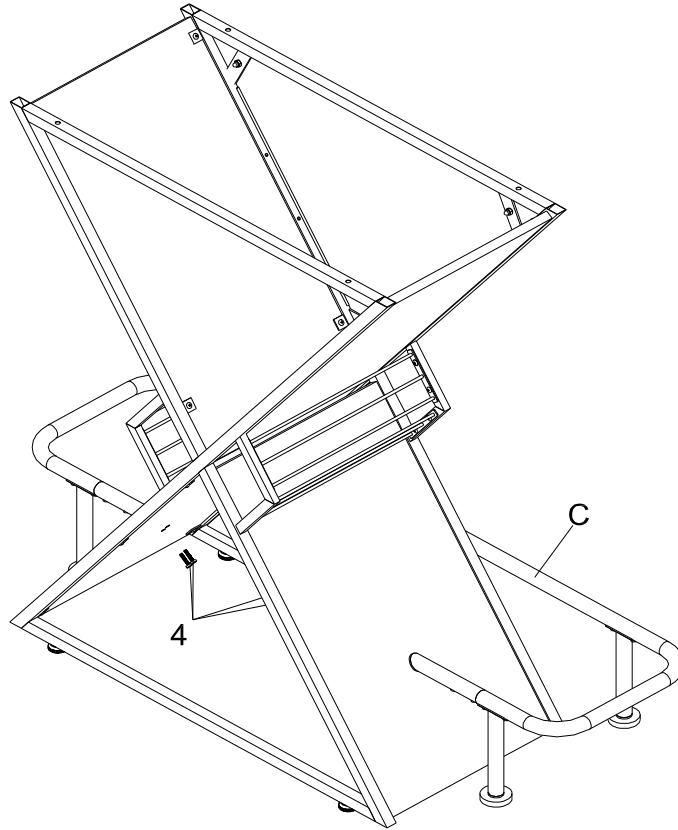

STEP 5

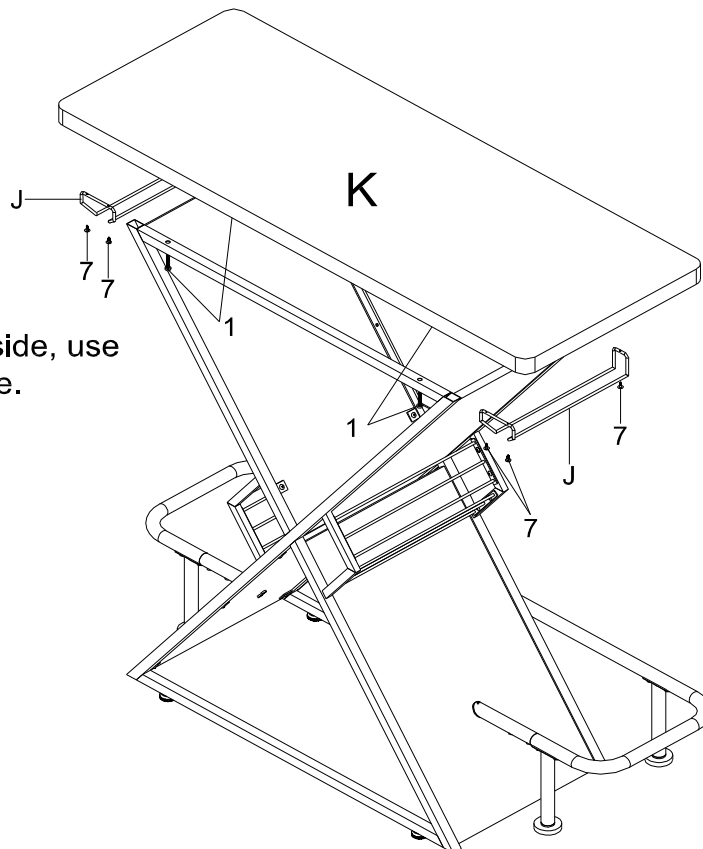

Same as the other side, use #7 3pcs to assemble.

STEP 6

Same as the other side, use #3 6pcs to assemble.

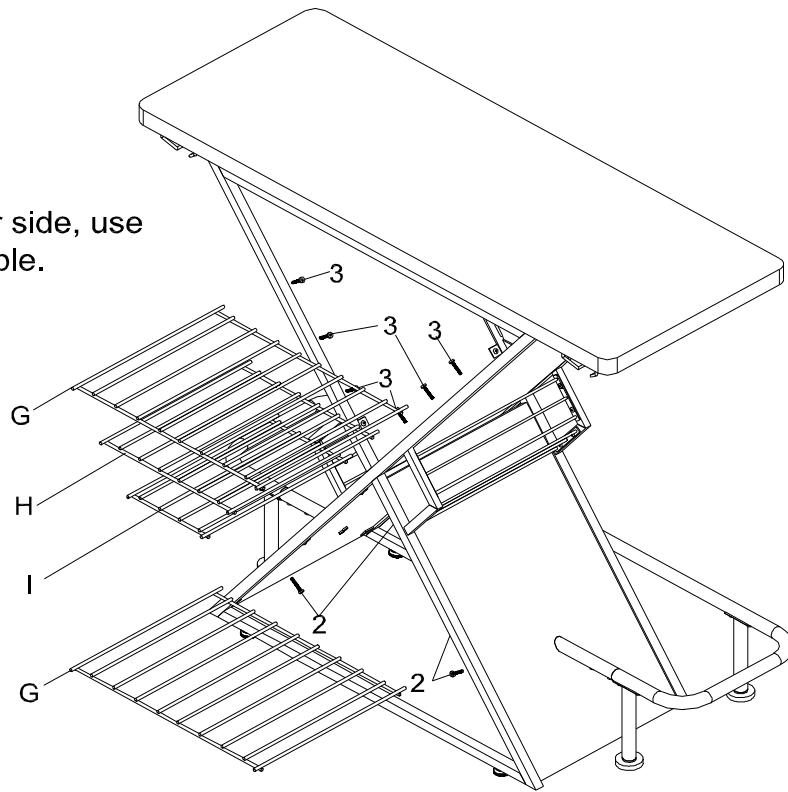

FINISH

