

**ASSEMBLY INSTRU**



[www.coastercompa](http://www.coastercompa)

**ASSEMBLY INSTRUCTION**

**ASSEMBLY TIPS:**

- 1.Remove hardware from box and sort by size.
- 2.Please check to see that all hardware and parts are present prior to start of assembly.
- 3.Please follow attached instructions in the same sequence as numbered to assure fast & easy assembly.







**Warning!!**

- 1.Don't attempt to repair or modify parts that are broken or defective.Please contact the store immediately.
- 2.This product is for home use only and not intended for commercial establishment.

**PARTS IDENTIFICATION:**

<b>A TOP WOOD</b>		<b>1PC</b>	<b>F LARGE SHELF CROSS BAR</b>		<b>2PCS</b>
<b>B SHELF GLASS</b>		<b>2PCS</b>	<b>G BOTTOM SHELF CROSS BAR</b>		<b>1PC</b>
<b>C BOTTOM WOOD</b>		<b>1PC</b>	<b>H GLASS HOLDER</b>		<b>3PCS</b>
<b>D SIDE WOOD</b>		<b>1PC</b>	<b>I SMALL CROSS BAR</b>		<b>1PC</b>
<b>E CENTER SUPPORT BAR</b>		<b>2PCS</b>			

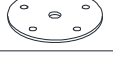
## HARDWARE PACKAGE:

Z	DESCRIPTION	FIGURE	Q'TY
1	CAM-1		2P
2	CAM-BOLT		2P
3	WOOD I		4P
4	GLASS		4P
5	GLASS BOLT		4P
6	SMALL SCREW		20P
7	BOLT		3P
8	LARGE SCREW		2P
9	PLASTIC WASHER		5P
10	SMALL WASHER		1P
11	SMALL ALLEN BOLT		1PC
12	ALLEN BOLT		1PC
13	F( ) I		5P
14	COVER LABEL		2P
15	ALLEN		1P
16	LARGE WASHER		1PC
17	ROUND		1PC
18	SPRING		1PC
19	LARGE ALLEN BOLT		1PC
20	GLUE		1PC

## STEI

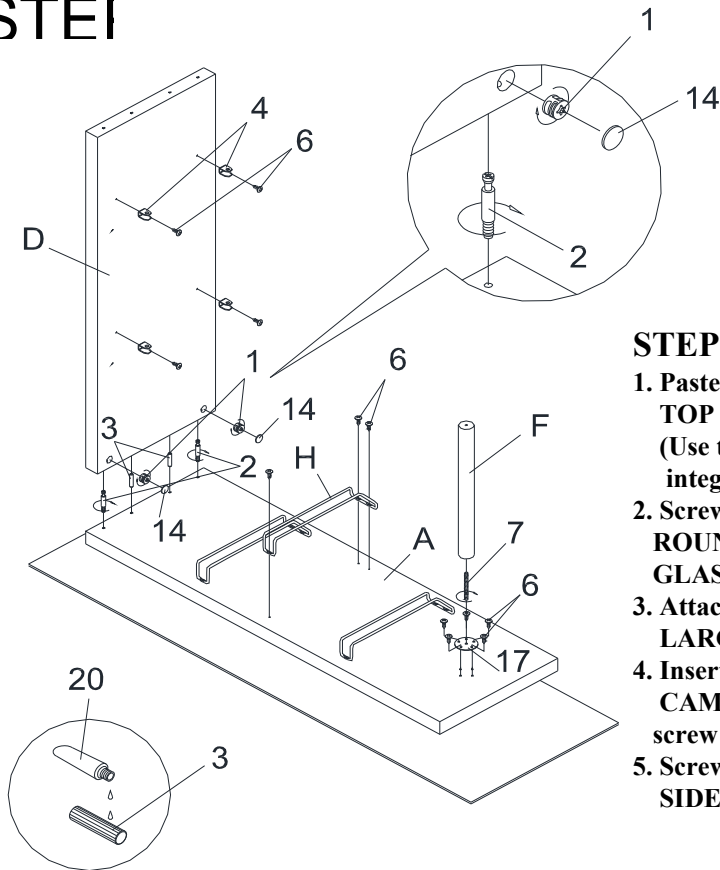

## STEP 1

1. Paste **GLUE (20)** on **WOOD DOWEL (3)** and insert into **TOP WOOD (A)** and **SIDE WOOD (D)**.  
(Use the glue when securing dowels to ensure the integrity of the structure.)
2. Screw **CAM-BOLT (2)** and **WOOD DOWEL (3)** and **ROUND IRON (17)** onto **TOP WOOD (A)**. Install **GLASS HOLDER (H)** using **SMALL SCREW (6)**.
3. Attach **ROUND IRON (17)** using **BOLT (7)** and attach **LARGE SHELF CROSS BAR (F)** using **BOLT (7)**.
4. Insert **SIDE WOOD (D)** into **TOP WOOD (A)** then install **CAM-LOCK (1)** and place **COVER LABELS (14)** on the screw hole after tightening.
5. Screw **GLASS METAL (4)** and **SMALL SCREW (6)** onto **SIDE WOOD (D)**.

## STEI

## STEP 2

1. Place **PLASTIC WASHER (9)** into **BOLT (7)** then install **BOLT (7)** and **GLASS METAL (4)** onto **SHELF GLASS (B)** and then tighten with **GLASS BOLT (5)**.
2. Place **PLASTIC WASHER (9)** into **BOLT (7)** then tighten with **LARGE SHELF CROSS BAR (F)**.

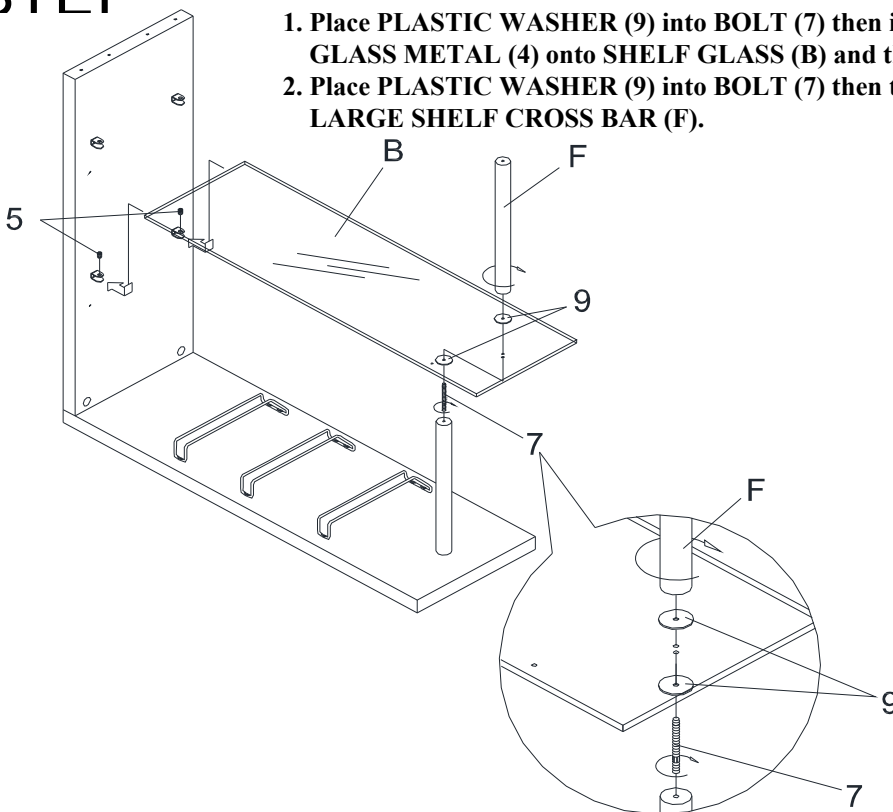

## STEI

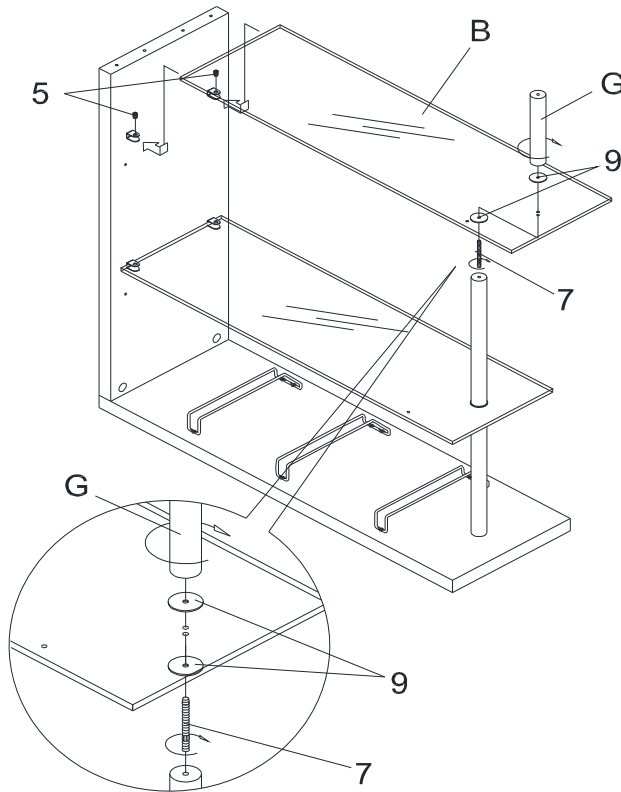

## STEP 3

1. Place PLASTIC WASHER (9) into BOLT (7) then install BOLT (7) and GLASS METAL (4) onto SHELF GLASS (B) and then tighten with GLASS BOLT (5).
2. Place PLASTIC WASHER (9) into BOLT (7) then tighten with BOTTOM SHELF CROSS BAR (G).

## STEI

## STEP 4

1. Insert FOOT PIN (13) onto BOTTOM WOOD (C).

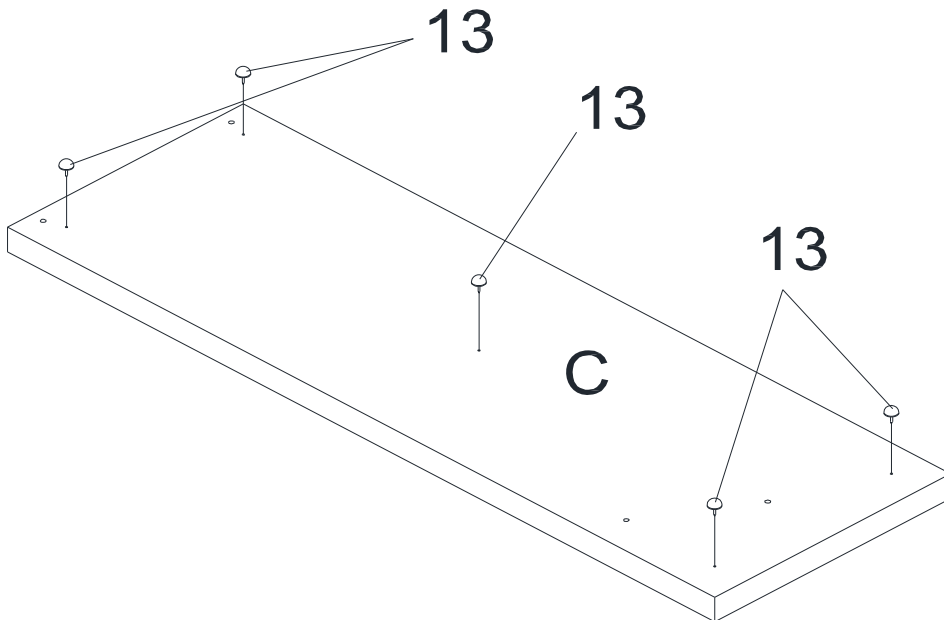

## STEI

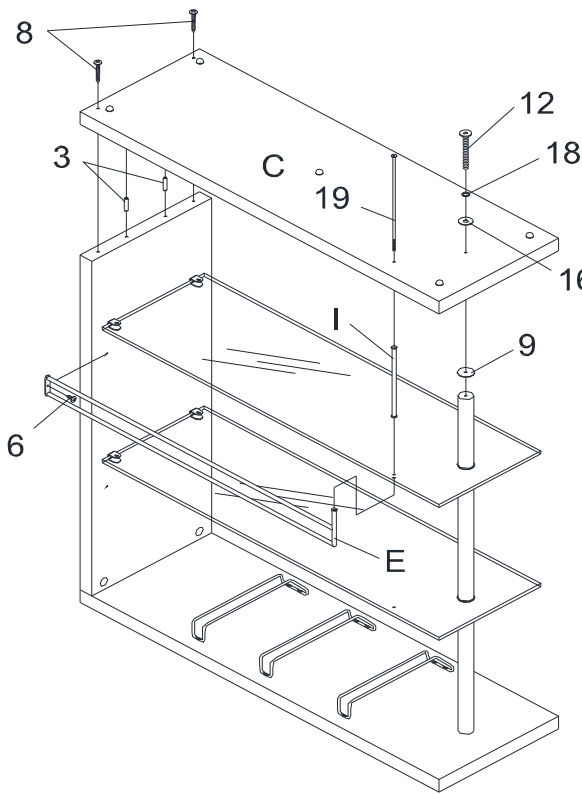

## STEP 5

1. Paste GLUE(20) on WOOD DOWEL(3) and insert into SIDE WOOD(D) and BOTTOM WOOD(C). (Use the glue when securing dowels to ensure the integrity of the structure).
2. Place PLASTIC WASHER (9) into BOTTOM SHELF CROSS BAR (G), screw WOOD DOWEL (3) onto SIDE WOOD (D). Insert BOTTOM WOOD (C) into SIDE WOOD (D) and tighten using LARGE SCREW (8).
3. Place SPRING WASHER (18) and LARGE WASHER (16) onto ALLEN BOLT (12) and then screw it to BOTTOM WOOD (C) with BOTTOM SHELF CROSS BAR (G) and PLASTIC WASHER (9).
4. Place SMALL CROSS BAR (I) into SHELF GLASS (B), Insert LARGE ALLEN BOLT (19) into SMALL CROSS BAR (I) and CENTER SUPPORT BAR (E) before tighten using LARGE SCREW (8).
5. Screw CENTER SUPPORT BAR (E) to the screw with SIDE WOOD (D) using SMALL SCREW (6).

## STEI

## FINISH

## STEP 6

1. Place SMALL WASHER (10) into SMALL ALLEN BOLT (11), screw SMALL ALLEN BOLT (11) onto CENTER SUPPORT BAR (E).
2. Screw CENTER SUPPORT BAR (E) to the screw with SIDE WOOD (D) using SMALL SCREW (6).

