ASSEMBLY INSTRU



ASSEMBLY INSTRUCTION

ASSEMBLY TIPS:

- 1.Remove hardware from box and sort by size.
- 2.Please check to see that all hardware and parts are present prior to start of assembly.
- 3.Please follow attached instructions in the same sequence as numbered to assure fast & easy assembly.







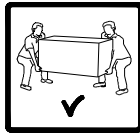

Warning!!

- 1.Don't attempt to repair or modify parts that are broken or defective. Please contact the store immediately.
- 2.This product is for home use only and not intended for commercial establishment.

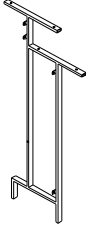
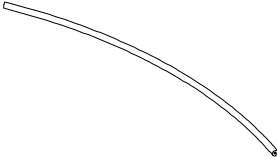
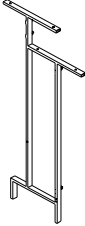
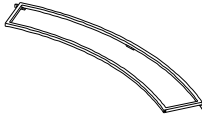

ASSEMBLY TIME PER UNIT: 70 MINUTES

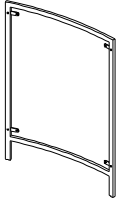

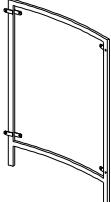
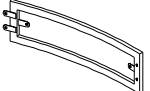
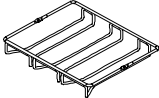



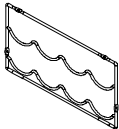
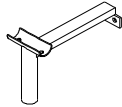
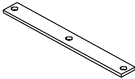
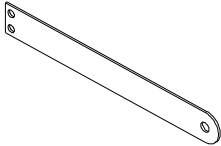
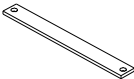
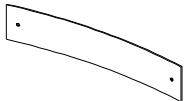
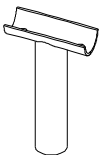
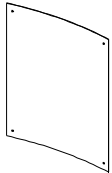

PARTS IDENTIFICATION







A		1PC	G		1PC
RIGHT SIDE			FOOT REST BAR		
B		1PC	H		1PC
LEFT SIDE			BOTTOM SHELF FRAME		
C		1PC	I		1PC
TOP GLASS SHELF			BOTTOM GLASS SHELF		
D		1PC	J		1PC
BAR TABLE GLASS			FRONT LARGE RIGHT PANEL		
E		1PC	K		1PC
FRONT SMALL RIGHT FRAME			FRONT LARGE LEFT PANEL		
F		1PC	L		1PC
FRONT SMALL LEFT FRAME			GLASS HOLDER		

PARTS IDENTIFICATION

<p>M</p> <p>BOTTLE RACK</p>  <p>2PCS</p>	<p>Q</p> <p>FOOT REST MIDDLE LEG</p>  <p>1PC</p>
<p>N</p> <p>BOTTLE RACK TOP BAR</p>  <p>2PCS</p>	<p>R</p> <p>FOOT REST SIDE PLATE</p>  <p>2PCS</p>
<p>O</p> <p>BOTTLE RACK BOTTOM BAR</p>  <p>2PCS</p>	<p>S</p> <p>SMALL ACRYLIC</p>  <p>2PCS</p>
<p>P</p> <p>FOOT REST SIDE LEG</p>  <p>2PCS</p>	<p>T</p> <p>LARGE ACRYLIC</p>  <p>2PCS</p>

HARDWARE PACKAGE

Z	DESCRIPTION	FIGURE	Q'TY
1	LARGE ALLEN BOLT		2PCS
2	MEDIUM ALLEN BOLT		18PCS
3	SMALL ALLEN BOLT		20PCS
4	REC CAP		24PCS
5	ROUND CAP		3PCS
6	FLOOR LEVELER		3PCS
7	BOLT		2PCS
8	SUCTION CUP		6PCS
9	NUT		8PCS

10	BOTTLE RACK BOLT		12PCS
11	ALLEN KEY		1PC
12	HEXAGONAL KEY		1PC
13	BOLT		2PCS
14	PLASTIC BOLT		12PCS
15	WASHER		12PCS
16	HAT NUT		12PCS

STEP 1

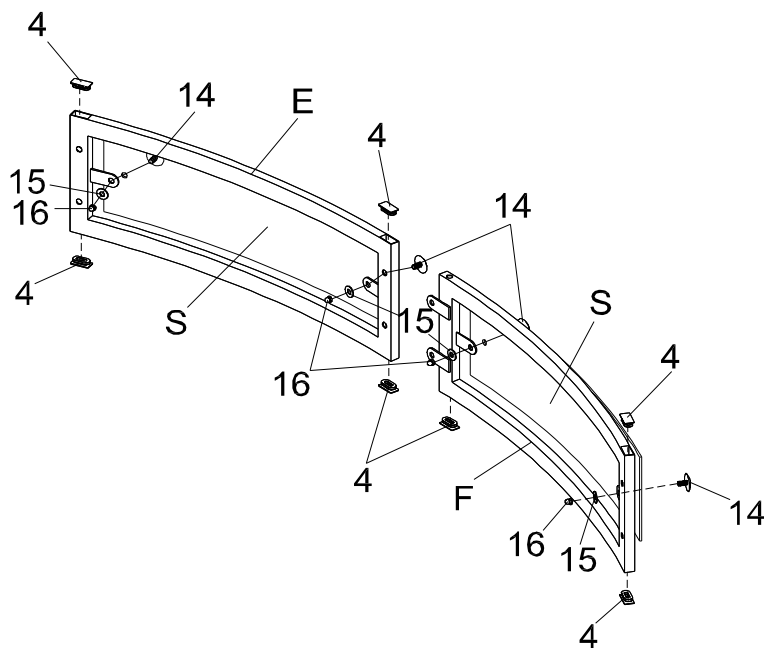

STEP 2

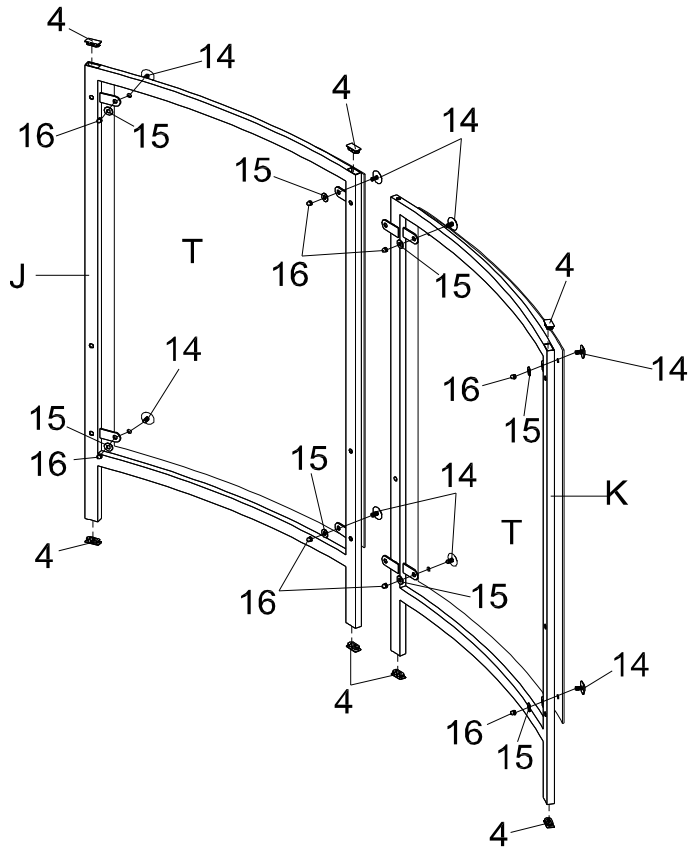

STEP 3

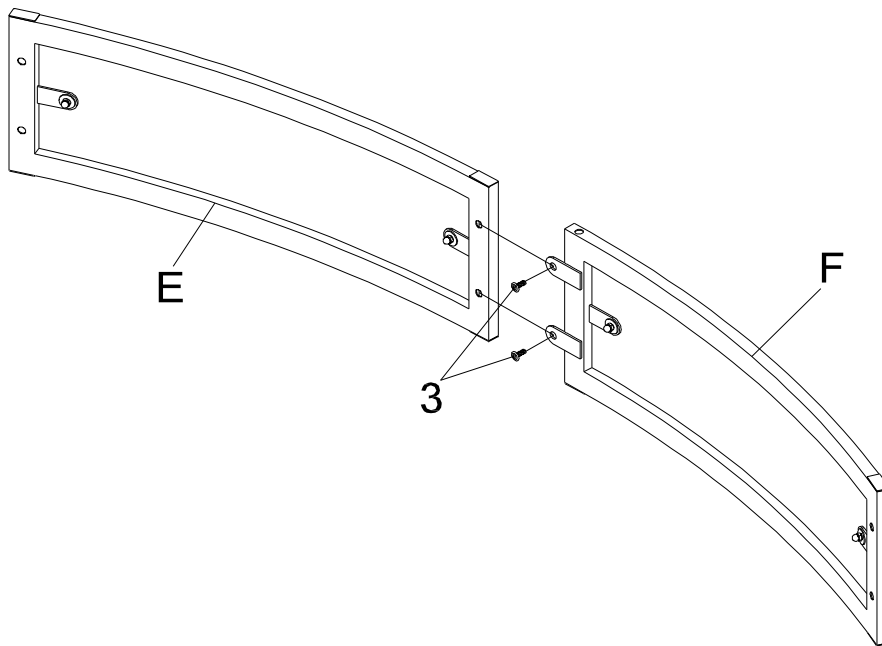

STEP 3

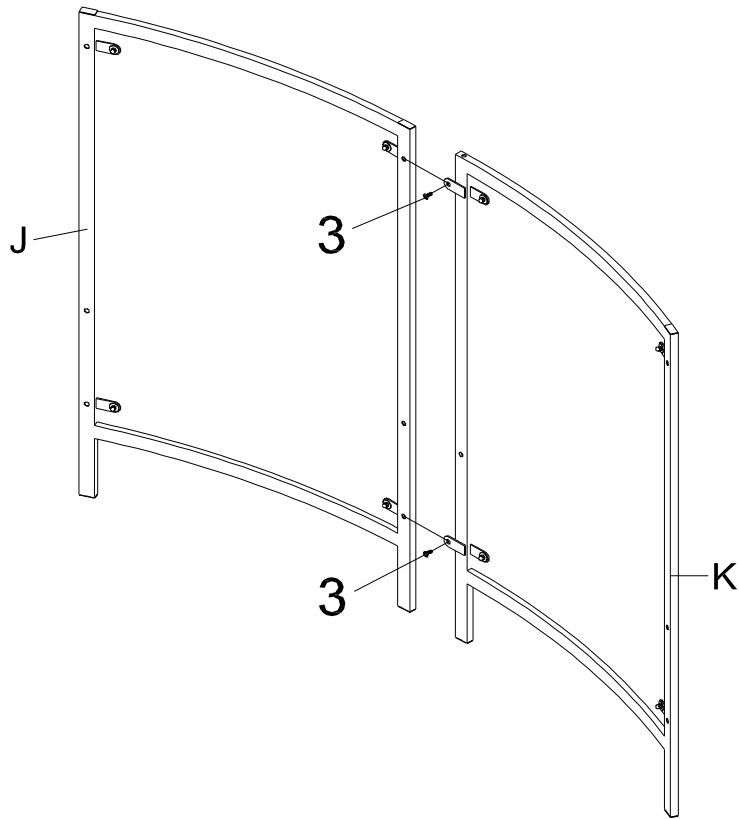

STEP 4

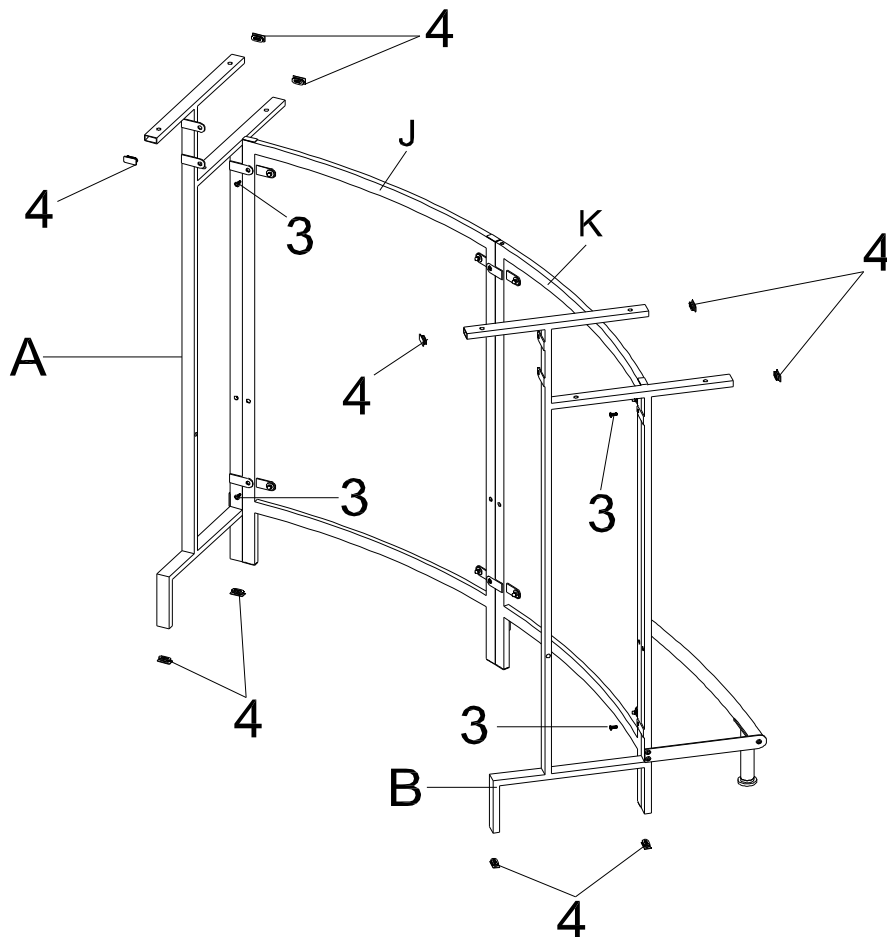

STEP 5

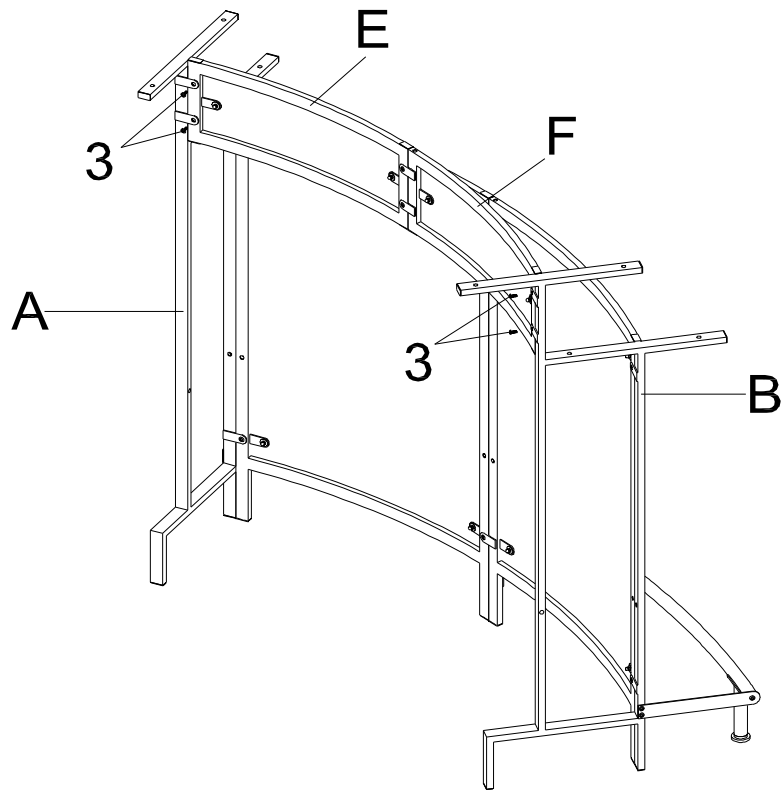

STEP 6

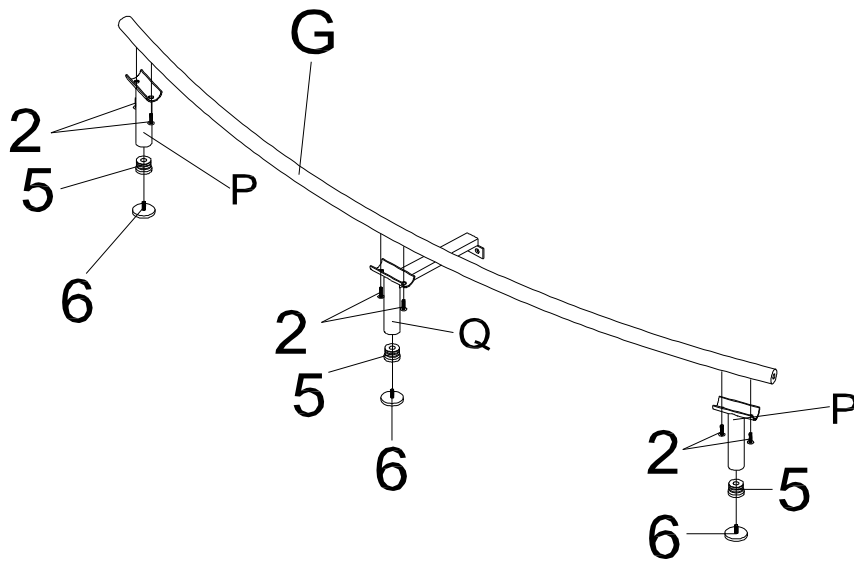

STEP 7

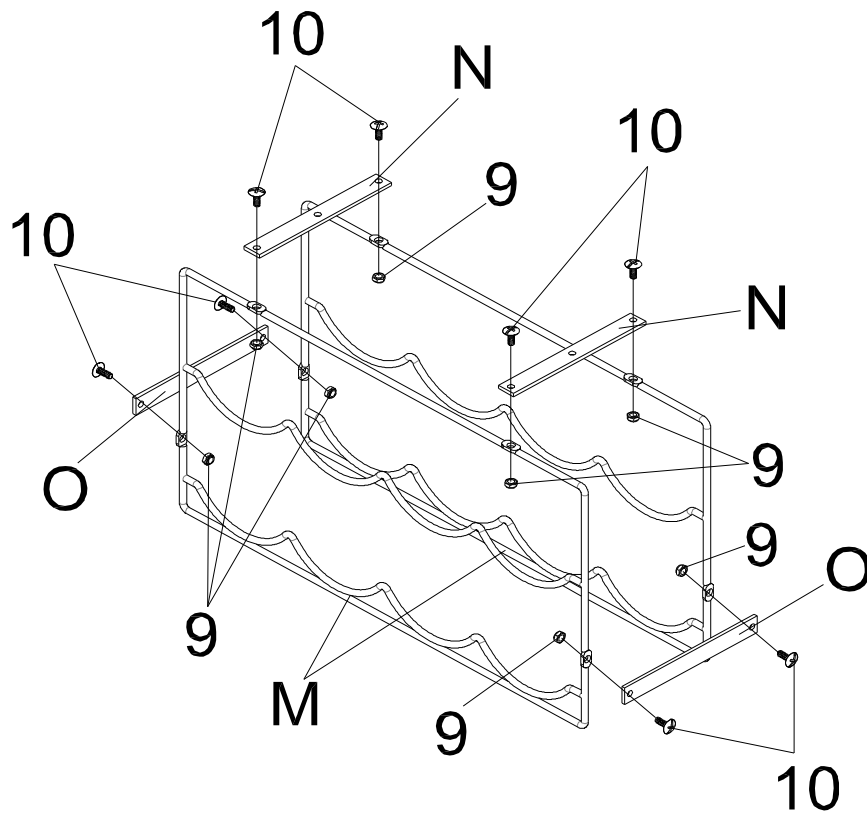

STEP 8

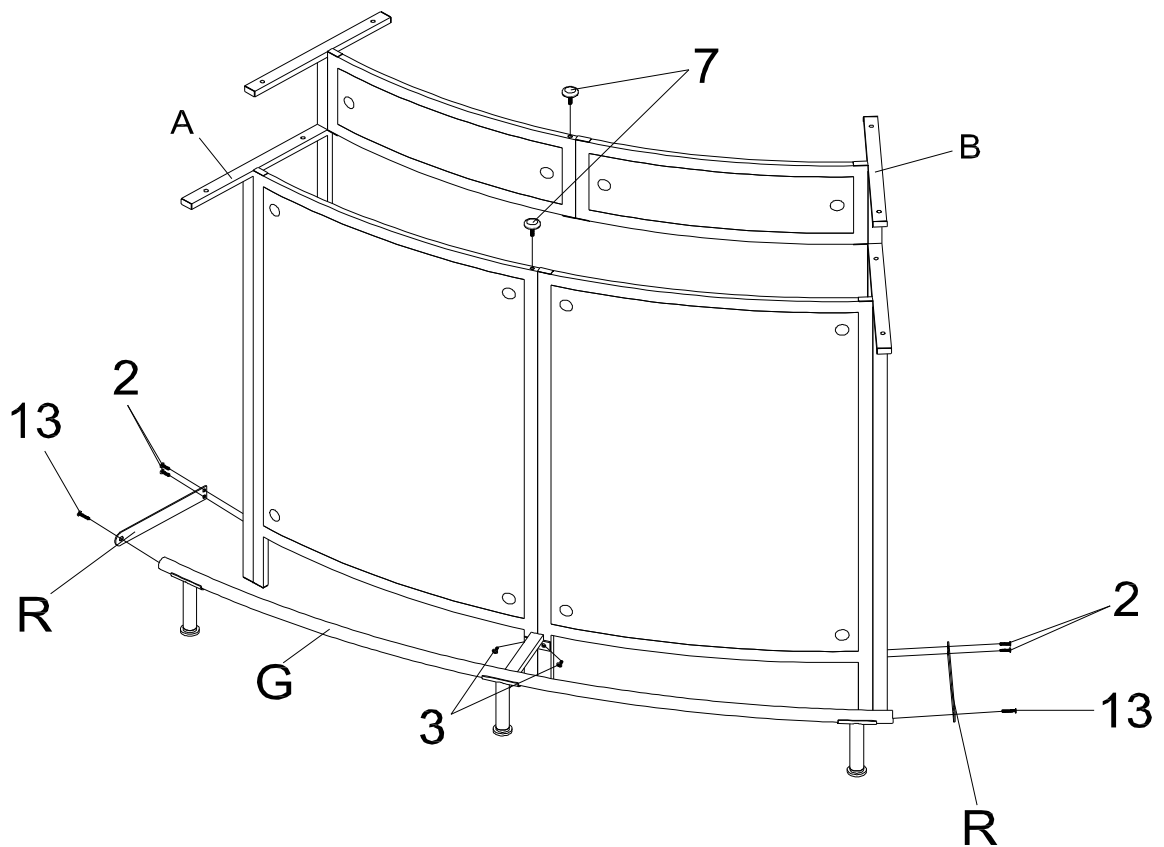

STEP 9

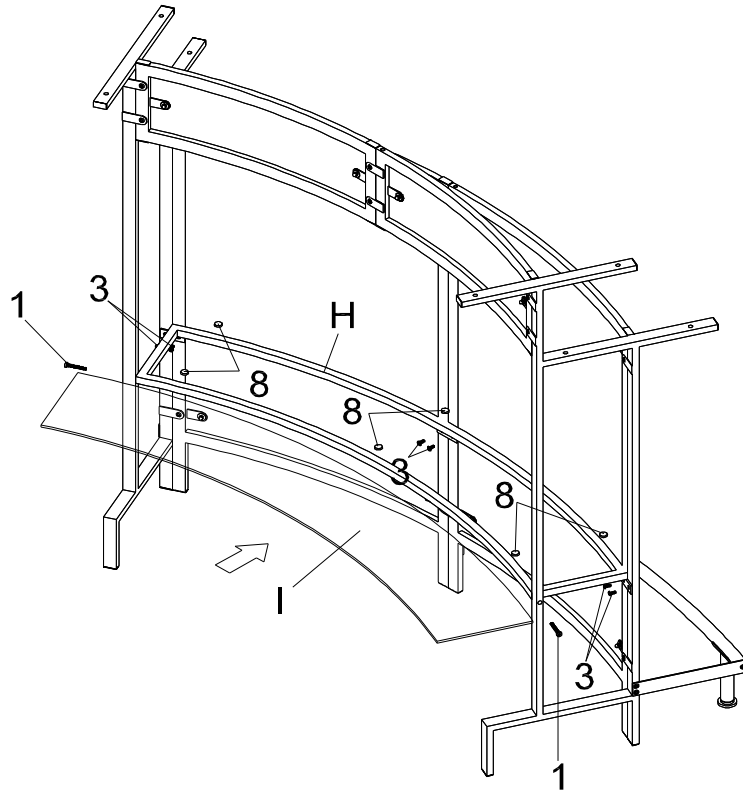

STEP 10

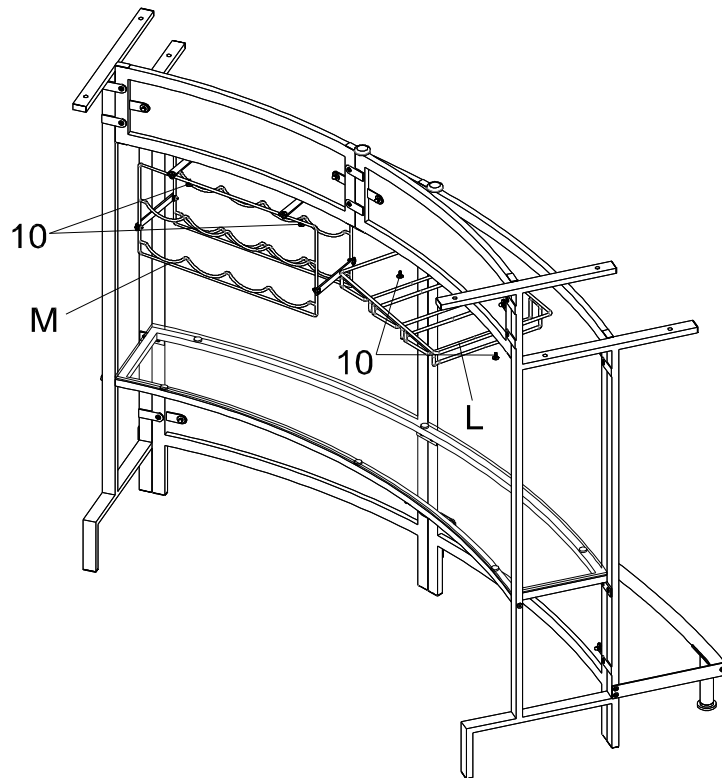

STEP 11

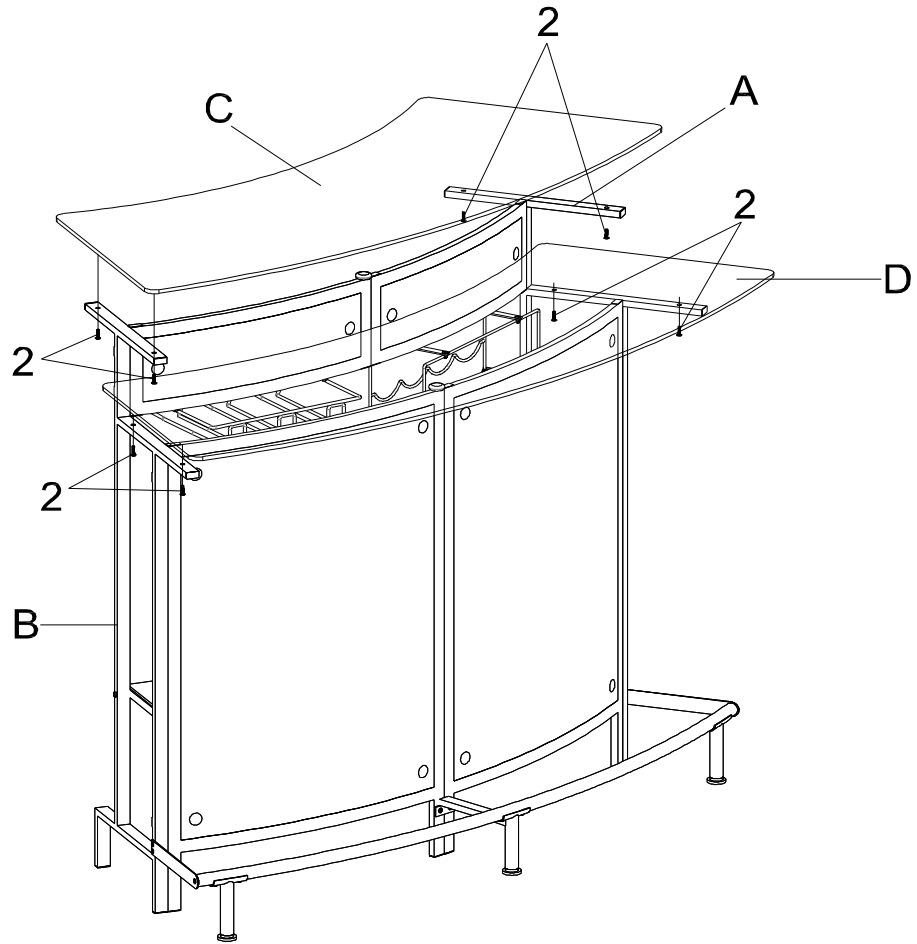

FINISH

