

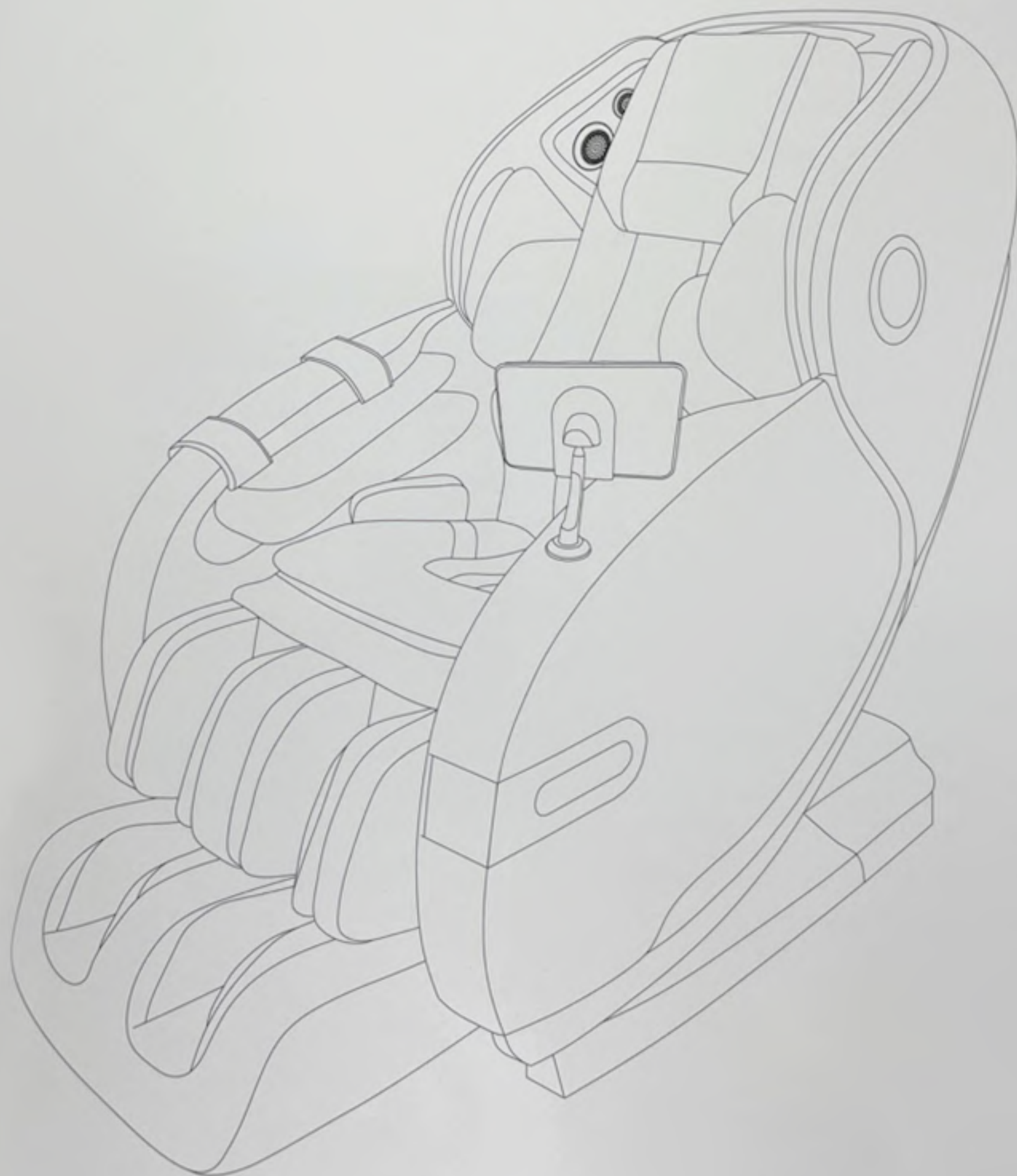

EVERYCARE  
**Massage Chair**  
**GF-500**  
**User 's Manual**







Please read SAFETY INSTRUCTIONS carefully before using the chair.

- ✦ ● Please read this manual carefully to make sure the installation and operation of the massage chair is correct.
- ✦ ● "Safety Instructions" is provided in both Warning and Caution for important safety information.

Both Warning and Caution are important safety caution, please pay more attention.

	<b>Warning</b>	This sign indicates warning of causing possible death or hurt to body.
	<b>Caution</b>	This sign indicates caution of causing possible hurt or damage to things.

## Symbol meaning

	This sign indicates forbidden behavior.		This sign indicates self disassembly is forbidden.
	This sign indicates must follow instruction to operate.		This sign indicates correct operation of cable.

- ✦ ● The following should be kept for any further references.



## Warning

	<ul style="list-style-type: none"> <li>● People with osteoporosis, vertebral fractures, and acute painful diseases such as sprains or muscle strains.</li> <li>● Heart disease patients (including those who have pacemakers or are using other medical electronics).</li> <li>● Cancer patients.</li> <li>● People with perceptual disorders due to high levels of peripheral circulatory disturbances such as diabetes.</li> <li>● People with abnormal spine or crooked spine.</li> <li>● People with Protruded intervertebral Disc.</li> <li>● Pregnant women and those who have just completed childbirth, as well as people with poor health.</li> <li>● People with trauma, such as thrombosis, acute varices, and various skin inflammations.</li> <li>● People who have been identified as having lost their ability to discern temperature.</li> <li>● People with high fever (acute inflammation: such as burnout, chills, blood pressure changes, physical weakness).</li> <li>● Elderly people over 80.</li> <li>● Persons with impaired consciousness, mentally handicapped persons, or those who are incapable of operating the unit are prohibited from using this unit.</li> <li>● People who can not take care of themselves, infants, and drunkards.</li> <li>● Do not use this unit when it is wet or when you are wet.</li> <li>● It must be taken care of, or not used by people who are not sensitive to heat or people who are allergic to heat.</li> <li>● Do not fall asleep in this unit.</li> </ul> <p>People with above symptoms should not use massage chair, or use it under doctor's advice. User's discretion is advised if use the chair.</p>	<p>Not suitable users.</p> <p>Risk of causing accident or body discomfort.</p>
---	---	--



## Warning

	<ul style="list-style-type: none"> <li>● Before sitting, please confirm that there are no foreign matter inclusions between the various parts of the machine.</li> <li>● When using the backrest , calf up &amp;down, or calf extend, be sure to check that there are no people or objects in the area (behind, under, or in front of the chair).</li> <li>● In the event of a physical abnormality or abnormality in use, stop using it immediately and ask a doctor.</li> <li>● Massage around the head should pay attention to the movement of the massage rollers, the head should not do too much or too strong massage.</li> <li>● Pay special attention when you massage the area around your neck.</li> <li>● Avoid excessive neck massage.</li> <li>● Do not massage the abdomen or knees with this machine.</li> <li>● If you want to leave your seat during the massage, you must stop the massage chair before you leave the seat.</li> <li>● Do not use it with other instruments.</li> <li>● Do not allow children or pets to play on or around the unit (especially in use); nor can they sit or stand on backrests ,armrests or legrest.</li> <li>● When people are inconvenient for action or lack of communication skills, they must have strict and continuous care.</li> <li>● Before moving the unit, the backrest and legrest must be angled back to their original position.</li> </ul>	<p>Accident/injury</p>
	<ul style="list-style-type: none"> <li>● When assembling, turn off the switch and unplug it after the chair returns.</li> <li>● Insert the plug of the chair into correct and suitable power socket. Make sure the plug is completely inserted into the socket to reduce short circuit or fire risk.</li> <li>● Unplug the power when not in use, stop all massage functions and turn off on/off key before unplugging.</li> </ul>	<p>Fire and electric shock</p>
	<ul style="list-style-type: none"> <li>● Massage cushions of the chair are not allowed to fold for storage.</li> <li>● The machine is forbidden for no-load running for a long time.</li> <li>● An appliance should never be left unattended when plugged in.</li> </ul>	<p>Accident</p>
	<ul style="list-style-type: none"> <li>● Power cord, plug, socket can't be used in broken or loose contact condition.</li> <li>● Don't use other electric power except rated voltage in case of fire, electric shock or any breakdown.</li> <li>● Any broken, re-process, knotted, twisted power cord or pressed under heavy cargo is not allowed to use.</li> <li>● Never operate this appliance if it has a damaged cord or plug, if it is not working.</li> <li>● Keep the code away the heated surfaces.</li> </ul>	<p>Fire and electric shock</p>
	<ul style="list-style-type: none"> <li>● If the chair works dysfunctional, or is broken, splashed with water or falls into water, please have it repaired by professional repairman or send the chair to assigned service agent. Self-modification, disassembly or maintenance is forbidden.</li> <li>● If power cord or plug is damaged, please don't replace it yourself, please contact us or appointed dealer for replacement.</li> <li>● To avoid electric shock or body hurt, please don't open or disassemble any part of the chair, there is not any attached part of the chair for maintenance by customers.</li> <li>● Check leather or cloth material on the back and other areas is broken or not. If broken, even though it is small, please stop using the chair, unplug the power and have it repaired</li> </ul>	<p>Disassembly and maintenance</p>

Preparation



## Caution

	<ul style="list-style-type: none"> <li>● Please operate the chair in a flat or level place.</li> </ul>	To avoid sudden falling.	
	<ul style="list-style-type: none"> <li>● The maximum suggested operating time is 20mins. 5mins for each position beginning with the slight- step massage. Along continuous massage in the same position may cause uncomfortable feeling.</li> </ul>	Too long time massage is bad for your body.	
	<ul style="list-style-type: none"> <li>● Before sitting on the chair to avoid injury please inspect everything to confirm that the massage heads are in the correct position.</li> </ul>	To avoid accidental injury.	
	<ul style="list-style-type: none"> <li>● Hand control should be timely put into the hand control bag, do not arbitrarily put away, to avoid squeezing or drop damage.</li> </ul>		
	<ul style="list-style-type: none"> <li>● Please make sure that the power switch is at the "OFF" position before inserting the plug into the socket.</li> </ul>		
	<ul style="list-style-type: none"> <li>● Turn off all controls before removing plug from outlet.</li> </ul>	To avoid the accident when turn on the power.	
	<ul style="list-style-type: none"> <li>● Make sure the plug completely insert into the socket.</li> </ul>	To reduce short circuits and any fire hazard.	
	<ul style="list-style-type: none"> <li>● Checking whether any damage on wire, make sure no water or rubbish on wire.</li> </ul>	To avoid electric shock in any leakage or breakdown.	
<ul style="list-style-type: none"> <li>● Installing earth wire in correct way. The plug must be inserted into socket with earth connect, the earth connect couldn't be bend or cut off.</li> </ul>			
	<ul style="list-style-type: none"> <li>● Don't press with hands or step on the massage heads with feet.</li> <li>● Don't put hands between the working massage heads.</li> <li>● Don't put hands or feet in the gap of mechanical parts.</li> <li>● Don't drop or embed anything into the slot of massage chair.</li> <li>● Don't stand or sit or put anything on the backrest, armrest or leg-rest.</li> <li>● Don't move the chair during operation.</li> <li>● Don't stand on the chair during operation.</li> <li>● Don't pull out the plug or turn off the power during operation.</li> <li>● Don't put your hands or head between leg-rest or beneath.</li> <li>● Don't use the massage chair while wearing hair ornaments.</li> <li>● Don't put hard things in pocket when take buttocks and huckle massage.</li> <li>● Don't sit or press on the backrest when the chair is in reclining position.</li> <li>● Don't use at bare skin or were thin clothes, thin clothes may can achieve better massage effect, But it also may cause irritation to the skin or cryogenic burns.</li> <li>● Do not use massager in close proximity to loose clothing or jewelry. Keep long hair away from massager while in use.</li> </ul>	To avoid accidents or injury	
		<ul style="list-style-type: none"> <li>● Keep the chair away from heat, wet, sharp things and corrosive, inflammable, explosive environment.</li> <li>● To use electric blanket or other heating products on the chair is forbidden.</li> </ul>	To avoid fade, discolor on upholstery or hardened, deteriorated on PU.
		<ul style="list-style-type: none"> <li>● Keep the chair away from stove or other heating products.</li> </ul>	
		<ul style="list-style-type: none"> <li>● Don't put the chair directly under the sun or other high temperature places.</li> </ul>	
		<ul style="list-style-type: none"> <li>● Don't put in the space of dust serious or corrosive gas environment,</li> </ul>	
		<ul style="list-style-type: none"> <li>● Don't put the chair in a small space places or use in the bad air circulation places.</li> </ul>	
	<ul style="list-style-type: none"> <li>● Don't use the chair outdoor.</li> </ul>		

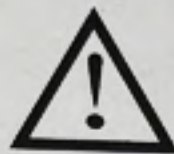

## Caution

	<ul style="list-style-type: none"> <li>● Keep Dry-Don't use or store the chair in the wet environment like nearing the swimming pool, or bathroom.</li> <li>● Keep the chair and remote control dry all the time.</li> <li>● Do not use it when user's body is wet.</li> </ul>	To avoid leakage or electric shock.
	<ul style="list-style-type: none"> <li>● Make sure to install the earth wire in correct way(Incorrect install way may cause electric shock. If you don't know how to install, please find a professional electrician)</li> <li>● Don't use plug adapter (If the enclosed plug doesn't match with socket, please don't change the plug by yourself and find a professional electrician to install a matched socket. )</li> </ul>	To avoid electric shock.
	<ul style="list-style-type: none"> <li>● Unplug the power before cleaning the chair.</li> <li>● Unplug the power after using the chair.</li> <li>● Unplug the power when any damage on the power.</li> <li>● Hold the plug to unplug the power but not try to pull the wire to unplug the power.</li> </ul>	To avoid electric shock or fire harzard.
	<ul style="list-style-type: none"> <li>● Please turn off the power switch and unplug the power after massage.</li> </ul>	To avoid accidents
	<ul style="list-style-type: none"> <li>● Unplug the power immediately when electricity goes off.</li> </ul>	To avoid damage or accidents when power on again.

### Grounding instruction

- ✦ ※The chair is equipped with a cord having a grounding conductor. The plug must be plugged into an appropriate socket that is properly installed and matched with the plug.

### Replace fuse

- ✦ ※When the fuse is burned out, please turn off the switch and unplug the power. Opening the lid covered the fuse which is located in the switch box. Using a same size fuse to replace the old one, then cover the lid. Or you can find an electrician to replace the fuse.

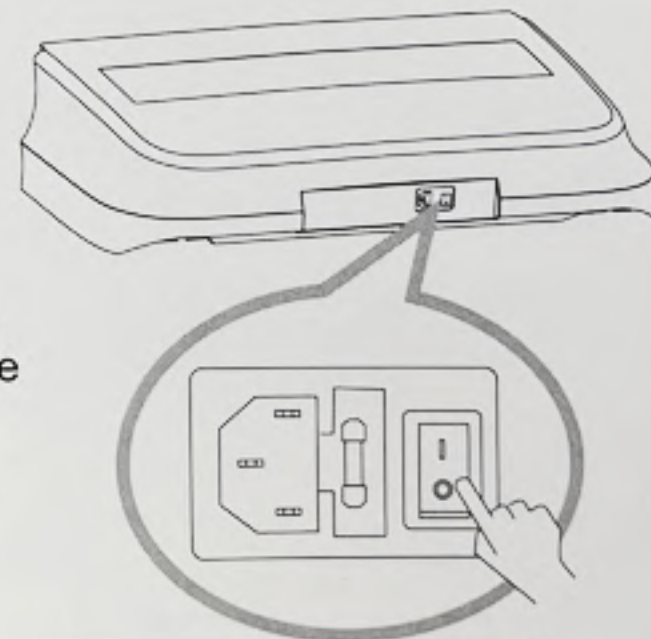

**Earth wire is not allowed to be in these places**

Gas pipe: probably cause explosion or fire.  
 Phone wire and lightning rod: probably cause electric shock and fire when thundering.  
 Water pipe: earth wire is useless where there are plastics

## External structure

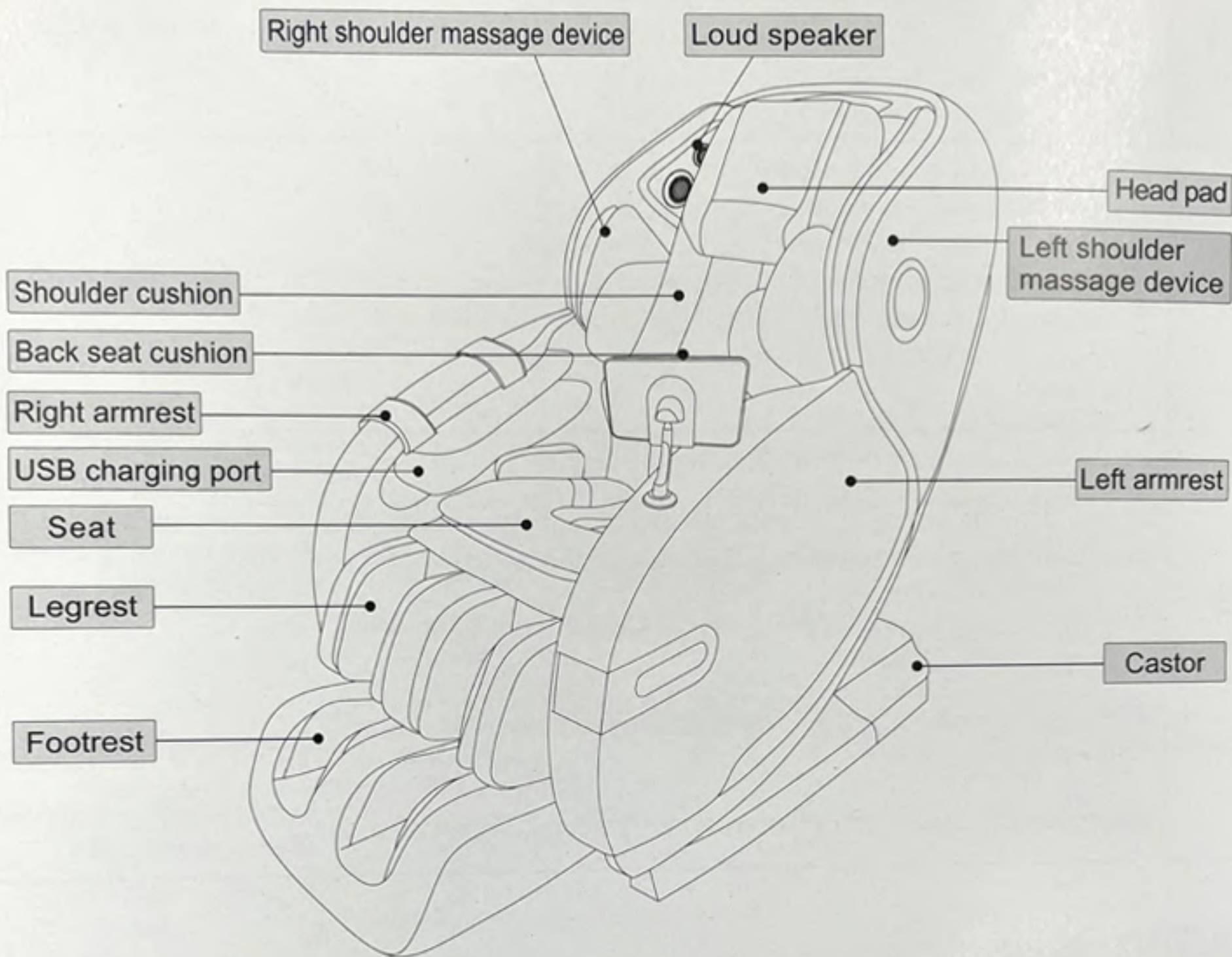

Preparation

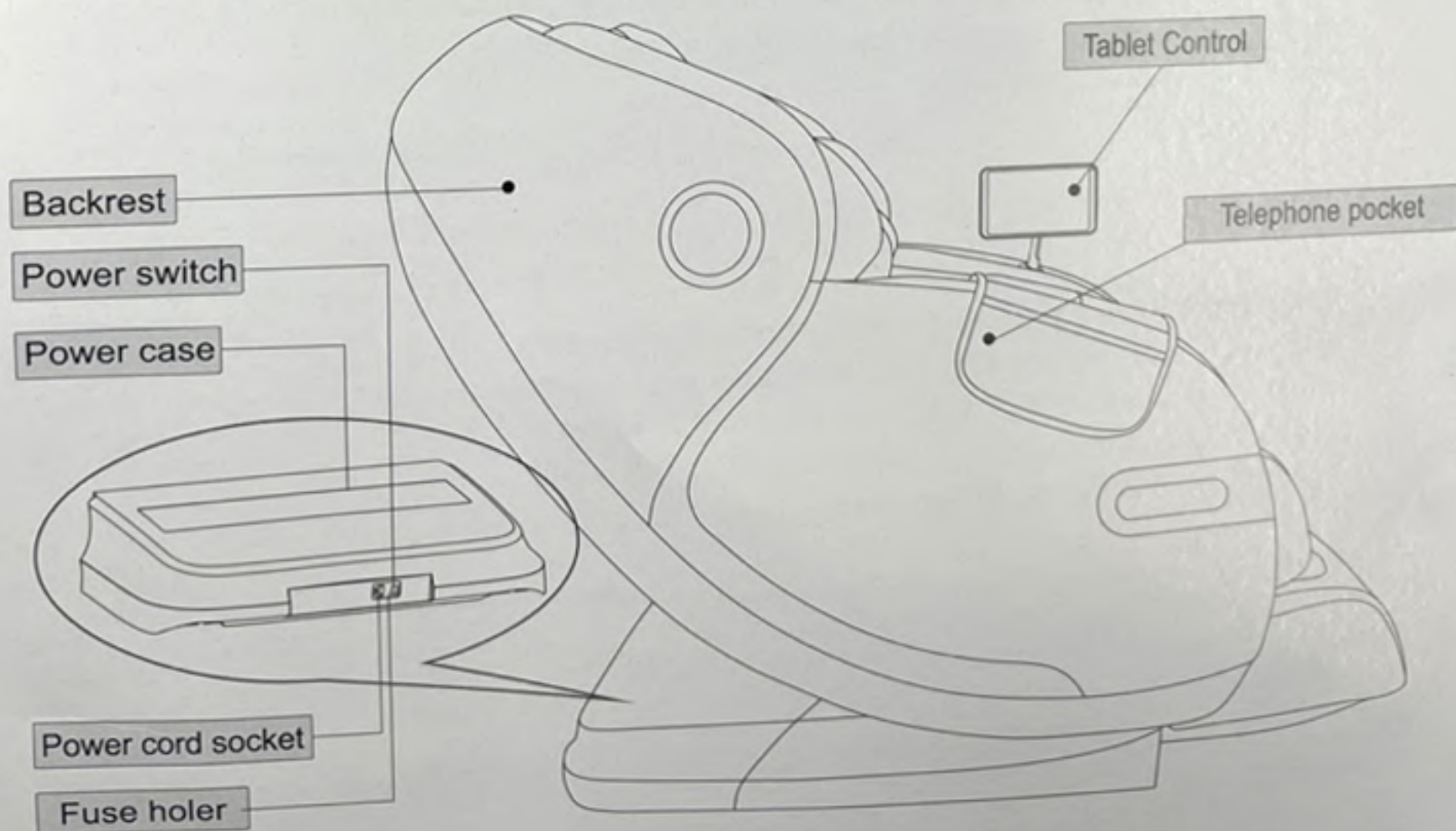

## Internal structure

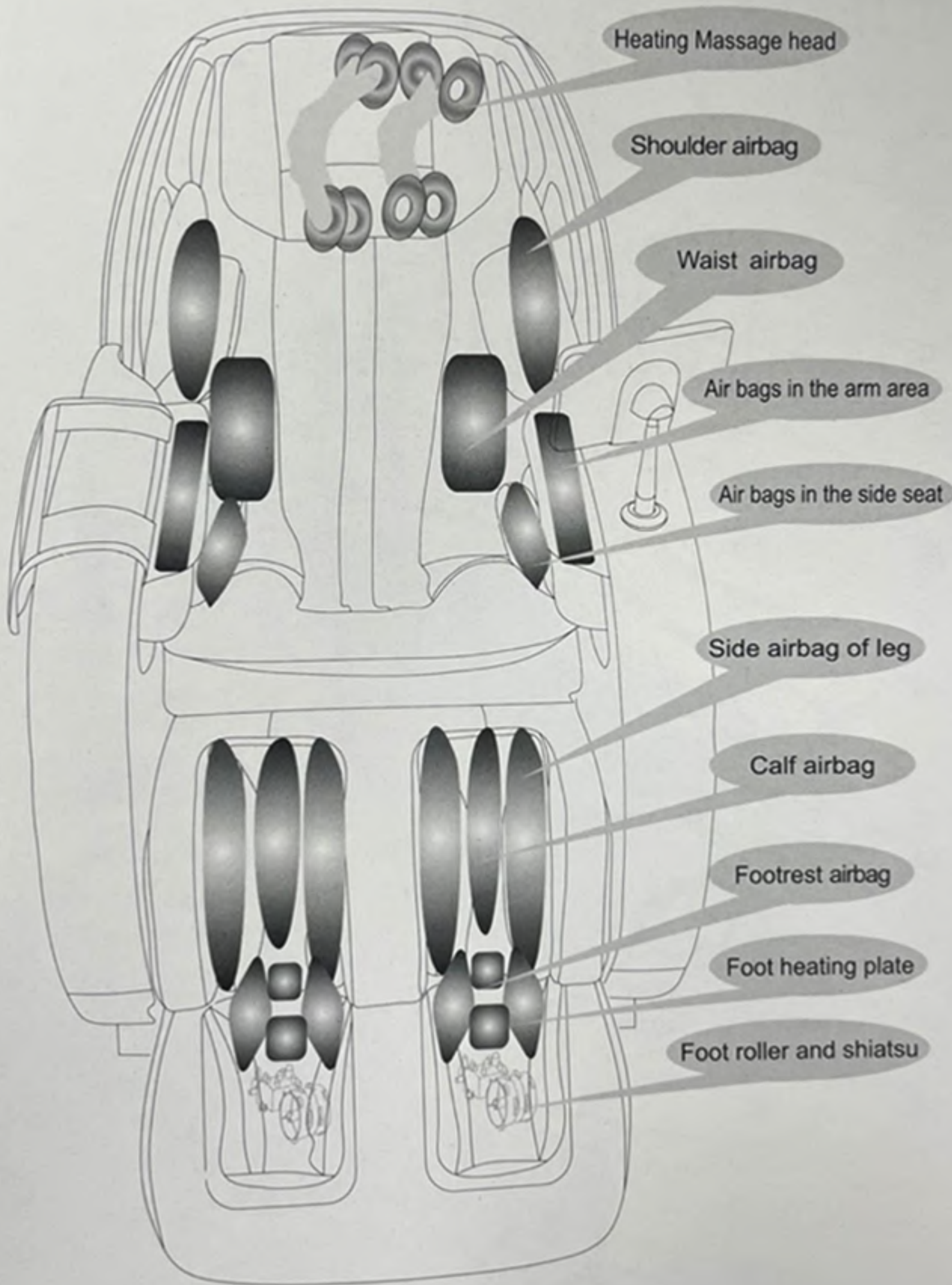

## Explosion Diagram

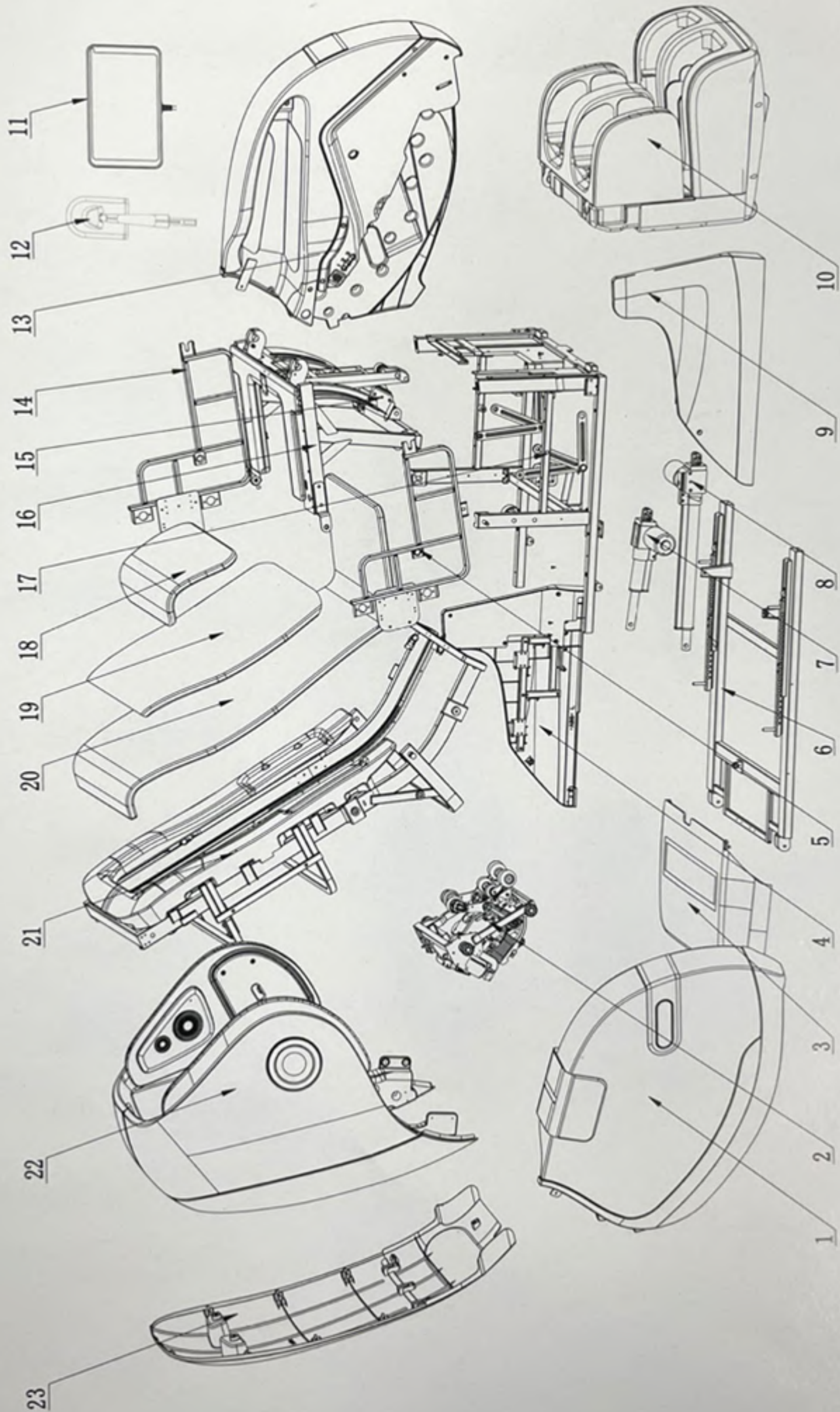

Preparation



## Mechanical components list

NO.	Name	Q' ty	NO.	Name	Q' ty
1	Right armrest assembly	1	22	Shoulder device assembly	1
2	Massage machine	1	23	Back cover assembly	1
3	Power case assembly	1			
4	Left side fender	1			
5	Right armrest frame assembly	1			
6	Under frame assembly	1			
7	Seat electric actuator	1			
8	Backrest electric actuator	1			
9	Right side fender	1			
10	Foot and leg assembly	1			
11	Tablet Control	1			
12	Tablet support pole	1			
13	Left amrest assembly	1			
14	Left armrest frame assembly	1			
15	Footrest electric actuator	1			
16	Seat frame surface assembly	1			
17	Seat bottom frame assembly	1			
18	Pillow	1			
19	Shoulder pad	1			
20	Back and seat cushion	1			
21	Backrest assembly	1			

## Installation (1)

**Step 1. Take out the main body and accessories from the carton box.**

- ① Take out the accessories boxes and the main chair from the carton box by at least three people .
- ② Confirm all the accessories.

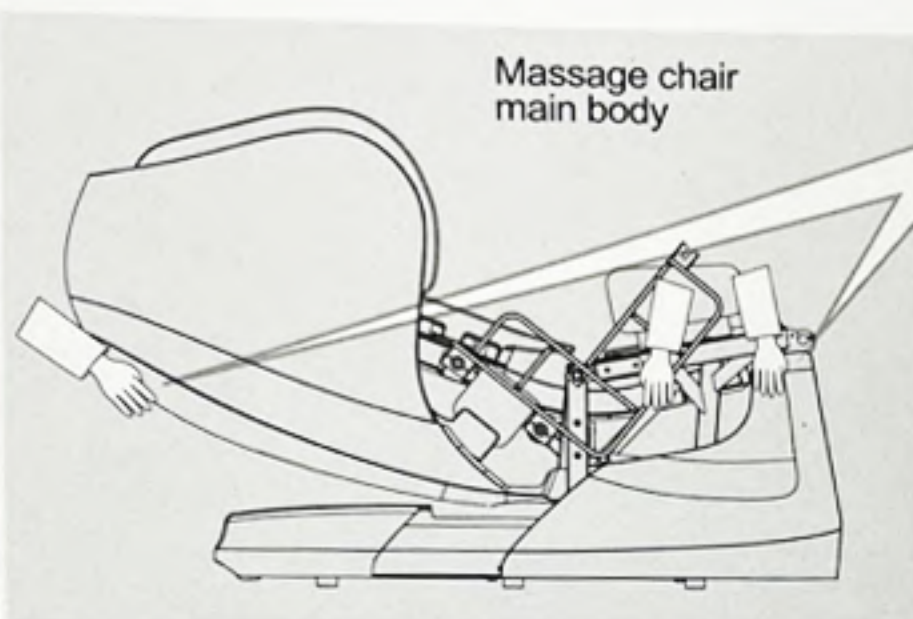

Two people grasp left and right seat metal frame ,the other one catch handling position of the back cover, then take the main body of massage chair out of the box .

**The accessories**

Head pad



Shoulder cushion

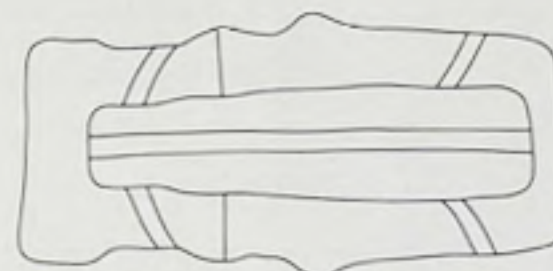

Back seat cushion



Tablet Control



Tablet support pole and screw



The left /right armrest exterior parts



Controller bag



Electric power cable



Left armrest



Right armrest

- ③ Take out the left ,right armrest from the armrest carton box,put the armrest on the table or ground in flat(pay attention to prevent scratches)

- ④ Taking out the legrest device from the legrest carton box,catching the front and back two sides of the legrest and take them out.

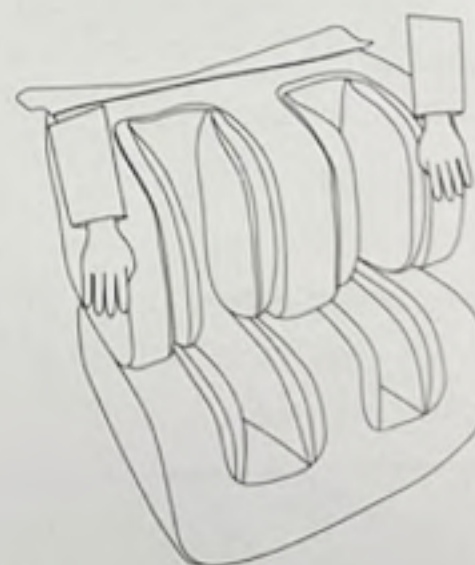

Legrest device

## Installation (2)

- **Check environment**
  - Make sure the recline space.

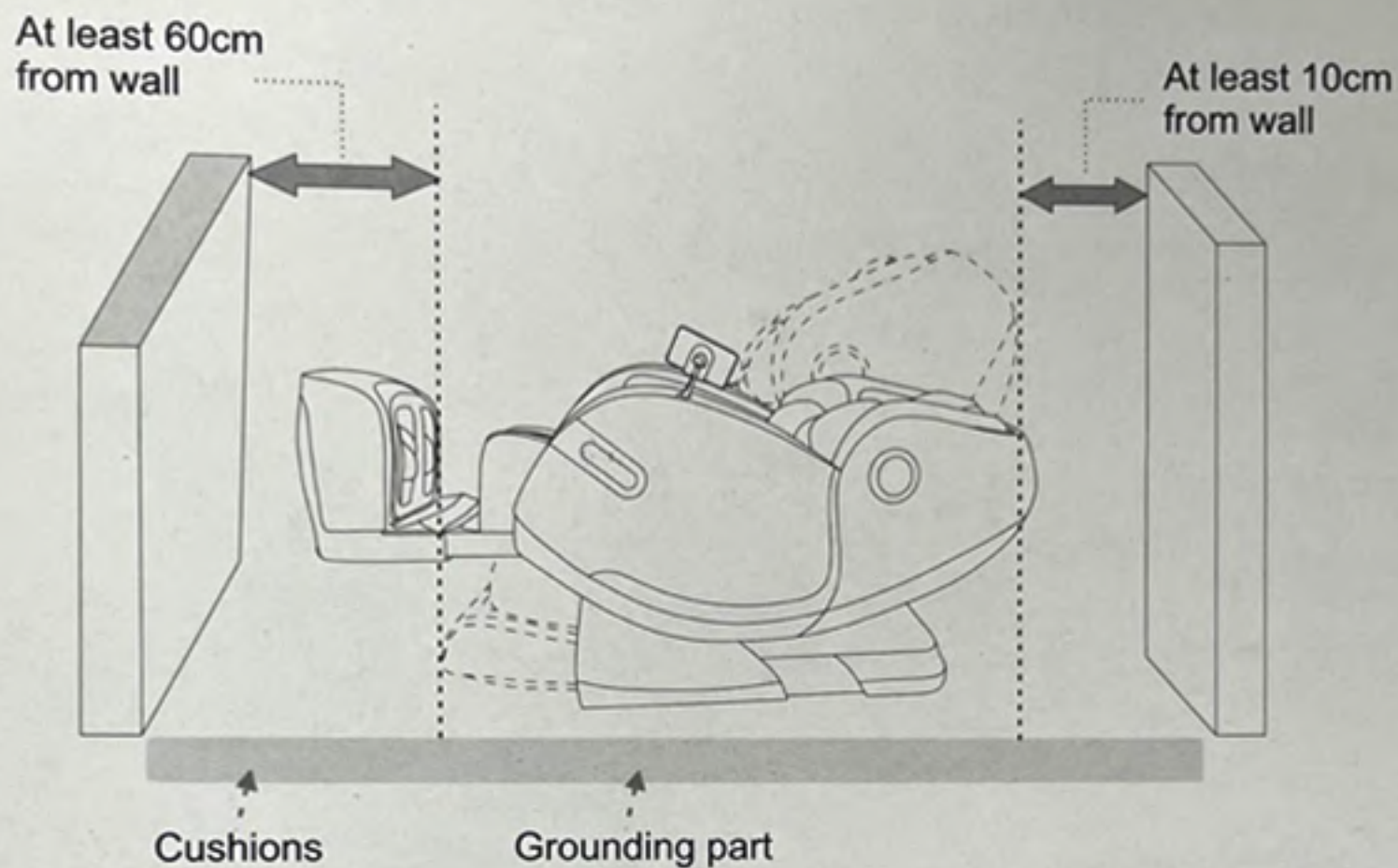

Because the chair is heavy, it may ruin your floor in long time setting. Please put a blanket or other soft things to protect your floor.

**Caution:**

- Don't use the chair in wet places like near swimming pool, bath room to avoid leakage or electric shock.
- Please use chair in flat place to avoid chair falling or noise or other unexpected trouble.
- Don't use under sunlight or near stove or other heating place to avoid upholstery deteriorated.

## Installation (3)

**Step 2. How to assemble the legrest**

- ① Unscrew the bolt from hanger of legrest.
- ② Connect the legrest's air hose with the corresponding air nozzles of the main body tightly.
- ③ Connect the cable plug and the socket.
- ④ Raise the rotation shaft board on hangers, raise the legrest with hands, put rotation shaft into hangers on main body, and put rotation shaft board down.
- ⑤ Screw it back tight.
- ⑥ Connect the legrest leather piece with seat by velcro .

**⚠ Attention:** When connecting the air pipe and cables, don't twist the air pipe and cables together.

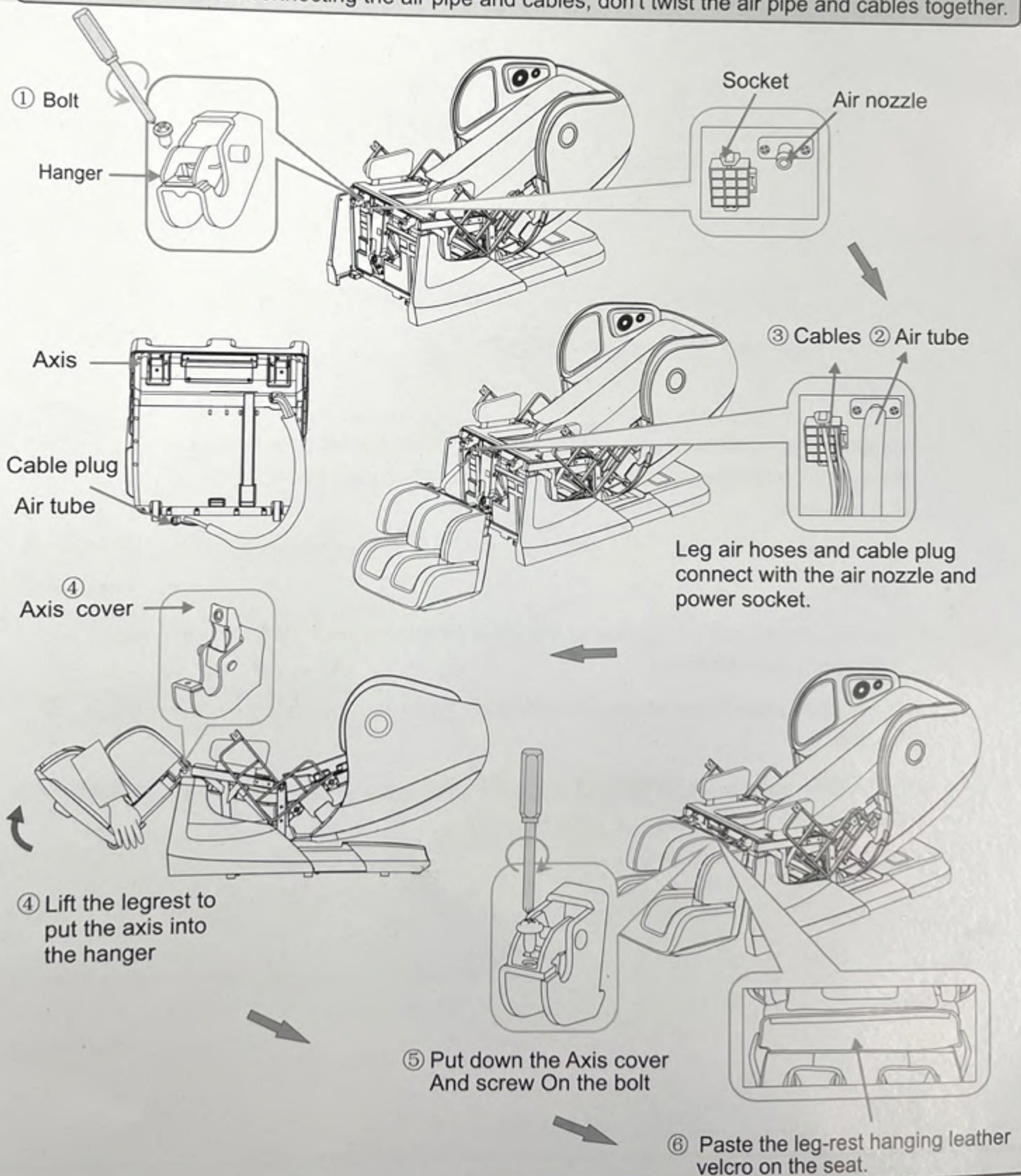

## Installation (4)

### Step 3. How to assemble the left and right armrest

- ① Lift the front armrest and plug it into the rotating stand on the side of the chair body and push back.
- ② Put the cable plug into the connector.
- ③ Connect the air tap of armrest with the air tubes on the seat tightly, the "1" air tube should be connected with the air tap marked with "1" and the "2" air tube should be connected with the air tap marked with "2".
- ④ Insert the 3 fixing peg of the arm outside part into the 3 fixing holes of the front bottom armrest, and buckle 8 snap joints in place.
- ⑤ Insert the 2 metal fixing part of the back armrest into the fixing hole on the back main body, and insert the up fixing part into the gap between shoulder frame and loudspeaker shell.
- ⑥ Remove the rubber plug of the armrest, spin the screws inside the hole tightly then put on the rubber plug tightly.

**Reminder:** when installing the left armrest, there's no cable, only install the air tube is ok.

**⚠ Caution:** Do not squeeze the air tubes during the installation. This may cause air leakage or the air bags not inflatable. Please make sure that the fixed plate and wire need to be plugged firmly, otherwise the armrest may drop or USB can't charge.

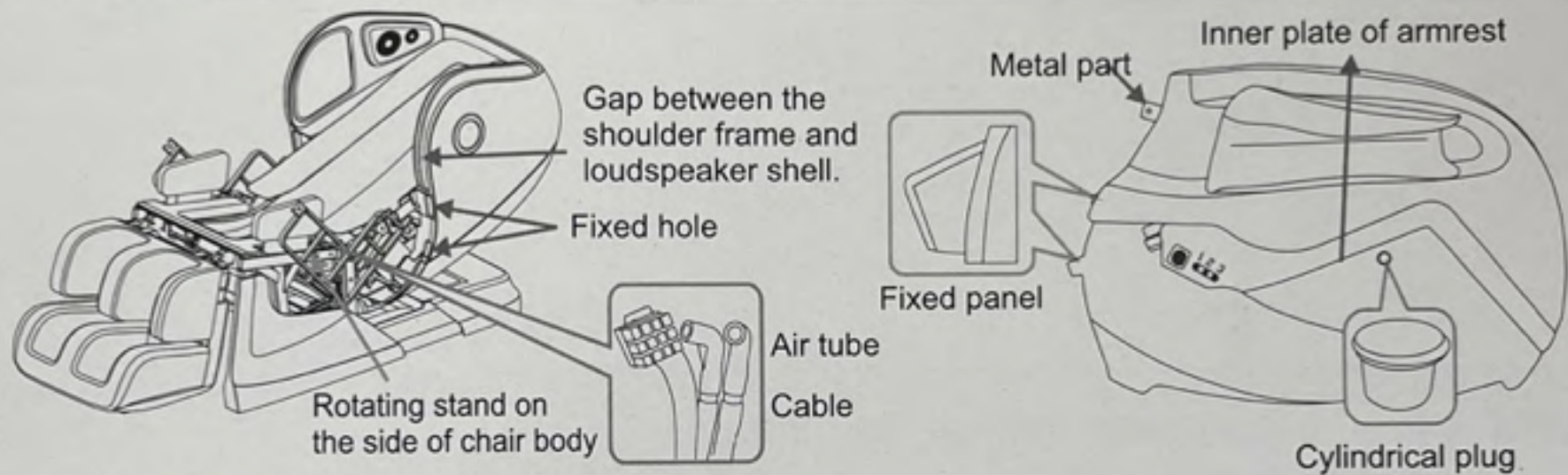

#### Assembly steps

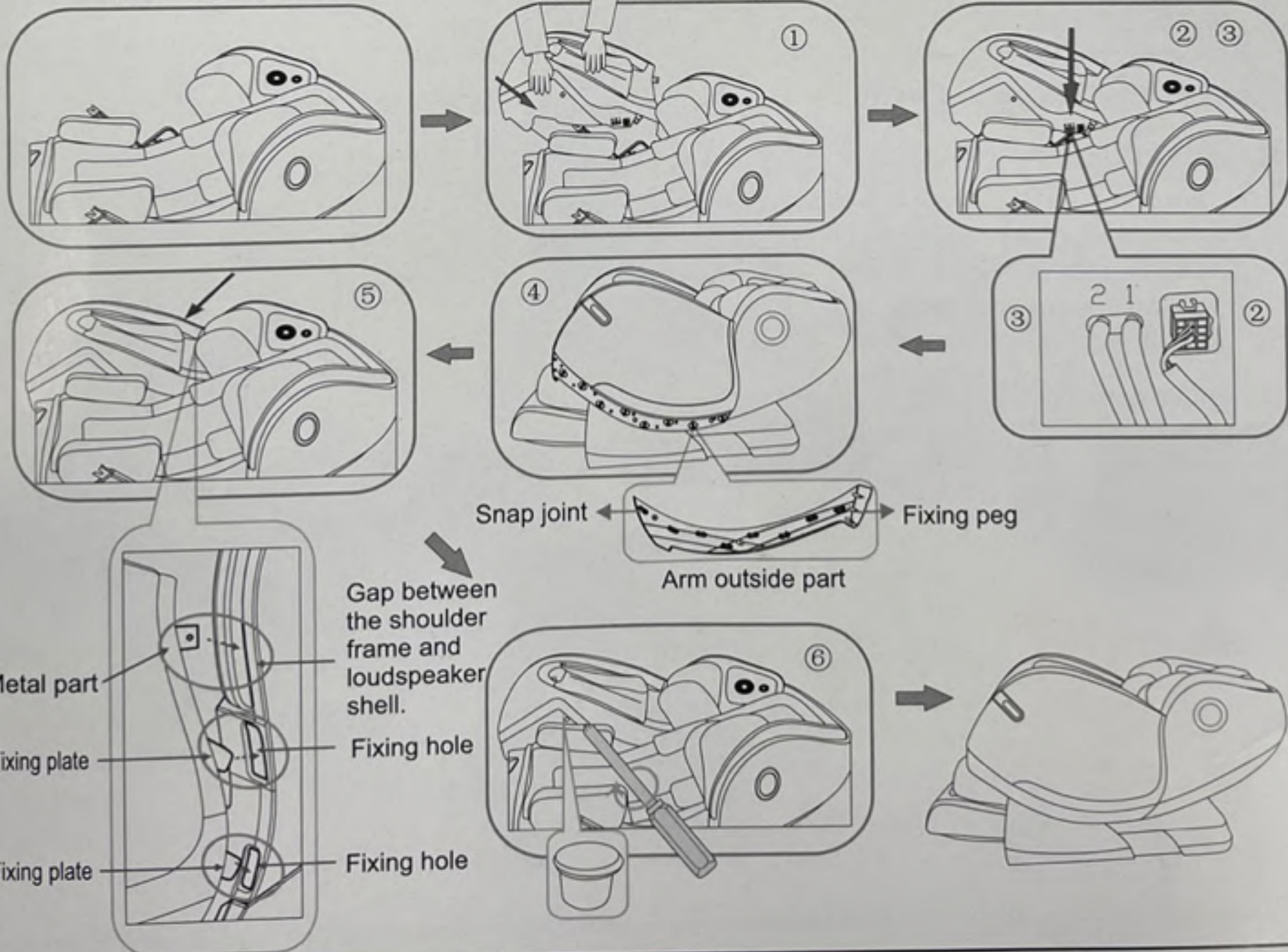

## Installation (5)

**Step 4. Install the hand controller and hand controller pocket.**

① Insert the Velcro of seat pocket through the upper position of arm airbag installed in right armrest, paste it on another Velcro, then you can put your telephone, watches and key ect. in this pocket for easy using.

② Insert the tablet supporting pole into the left armrest, when inserting please according to the shape between the pole and the hole on the armrest.

③ After insert the support pole, using M6\*16 screw tight it from the upper air bag of the armrest.

④ Put the tablet on the support pole.

⑤ Connect the tablet line into the massage chair with the line socket which on the left side of the seat part, then tight the screw nut.

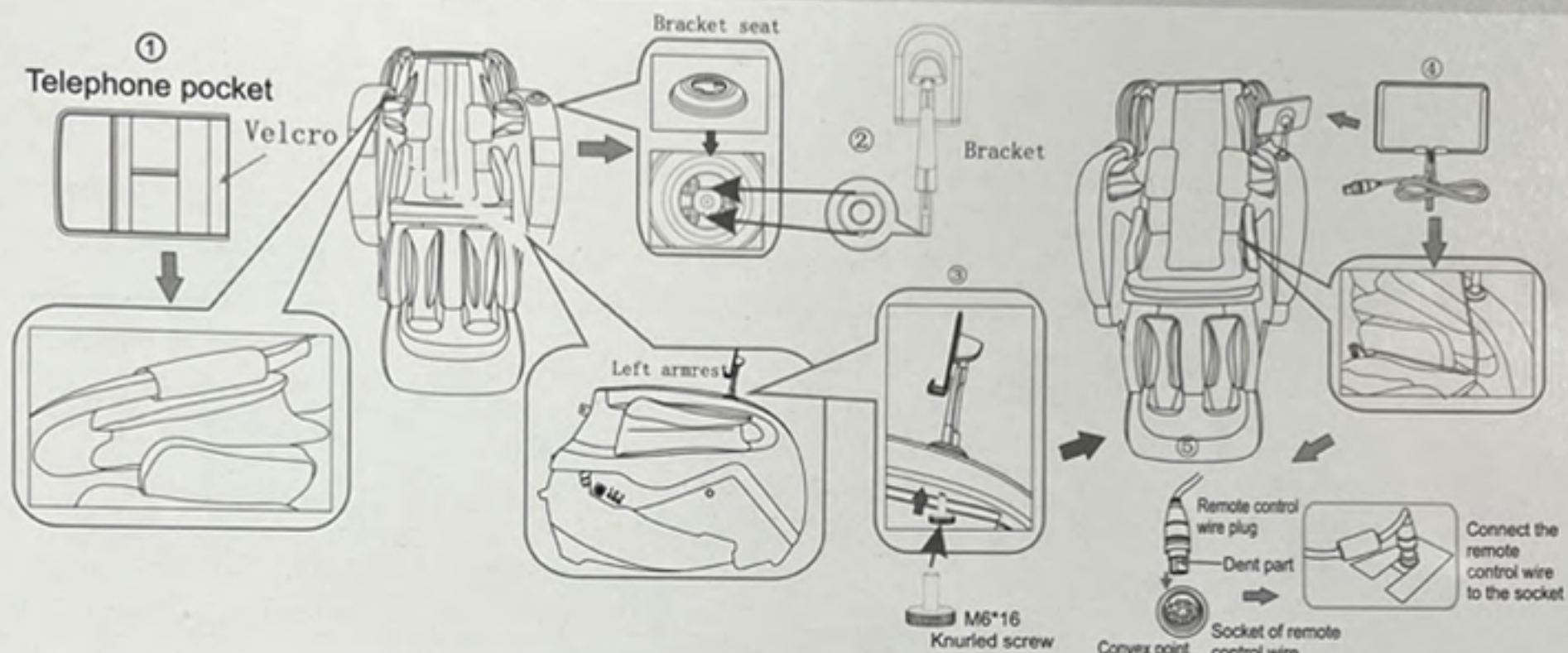
**Step 5. Install the back cushion, shoulder cushion and pillow.**

Put the back seat cushion, shoulder cushion, head pad onto the backrest and connect the two parts with zipper and velcro.

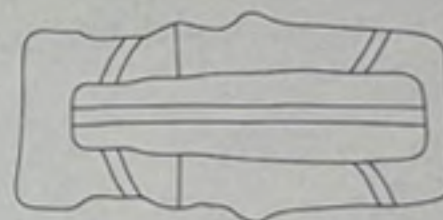

Back seat cushion

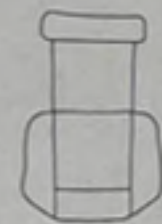

Head pad

**★ Warm tips**

In order to get exact correct body test data for comfortable massage effect, when you sit on the chair, please make the bottom rim of the head pad flush with your ears before zippering the said two parts.



Shoulder cushion

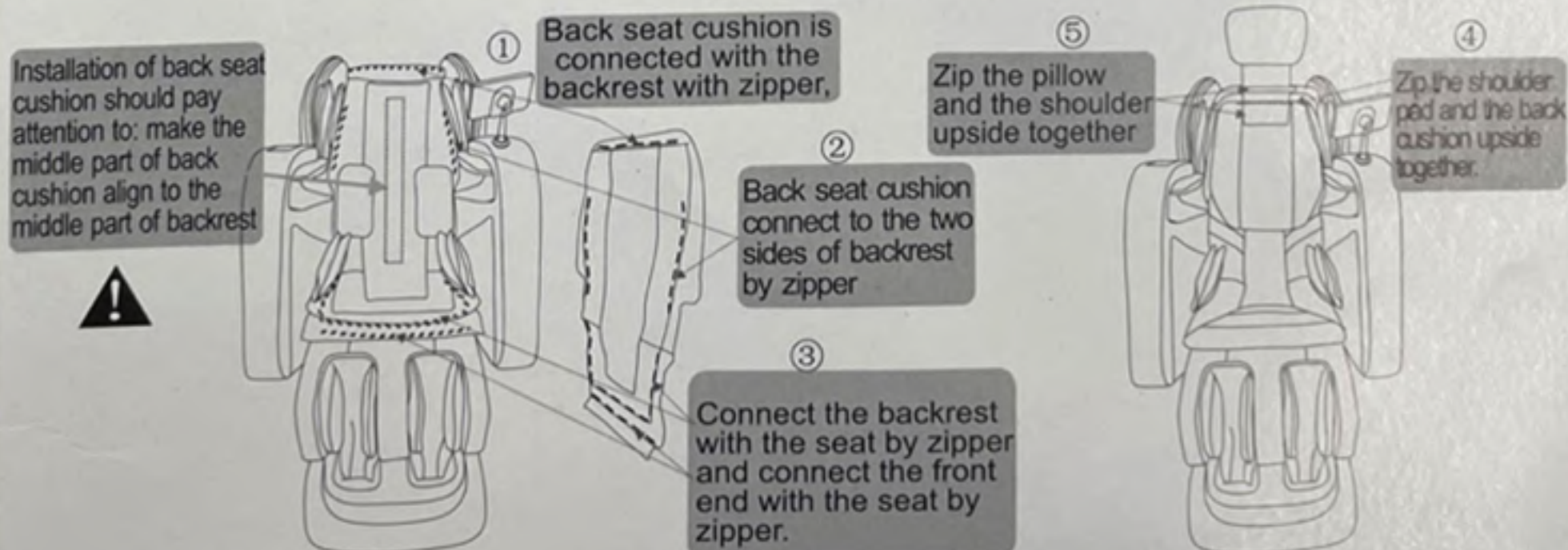

## Installation (6)

### Step 6. Restore the chair.

- 1 Plug the cable line in the hole a on the power box as shown in the right picture.
- 2 Insert the plug of cable line into the socket.
- 3 Turn on the switch behind the power box. (Switch on/off "O/I", press I down to turn it on.)
- 4 Switch off, chair resets to upright state.
- 5 Choose the massage function by hand controller ,then enjoy it .
- 6 In ON status, the USB port can be used for charging mobile. Do not move the mobile during charging.



Make sure the switch is off before you insert the plug of cable line into the socket.

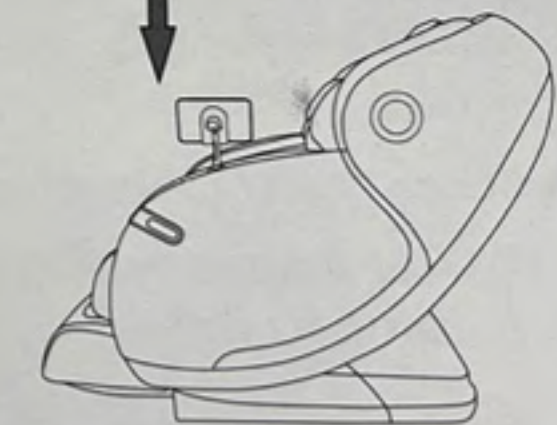
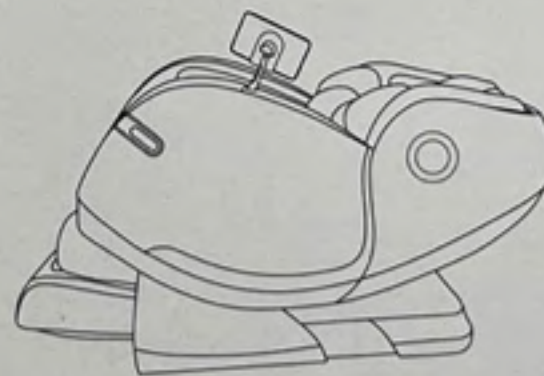
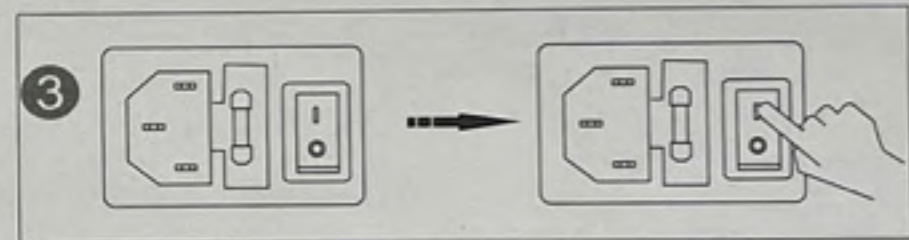
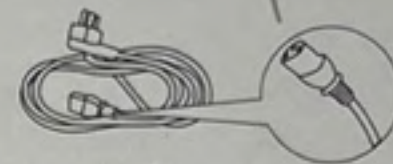
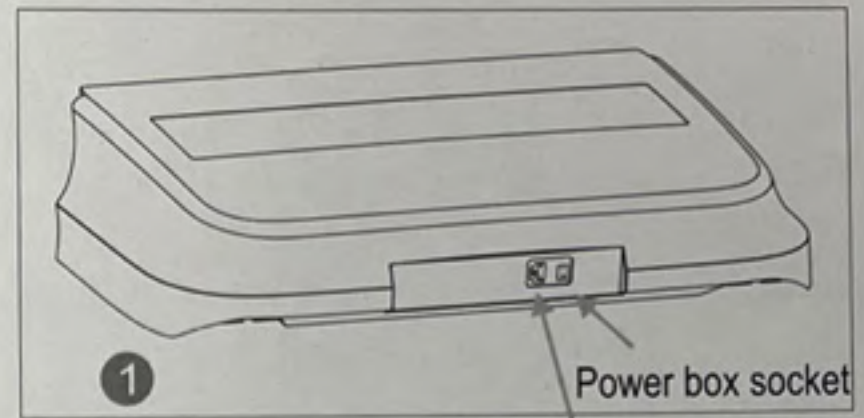

4 Chair resetting status

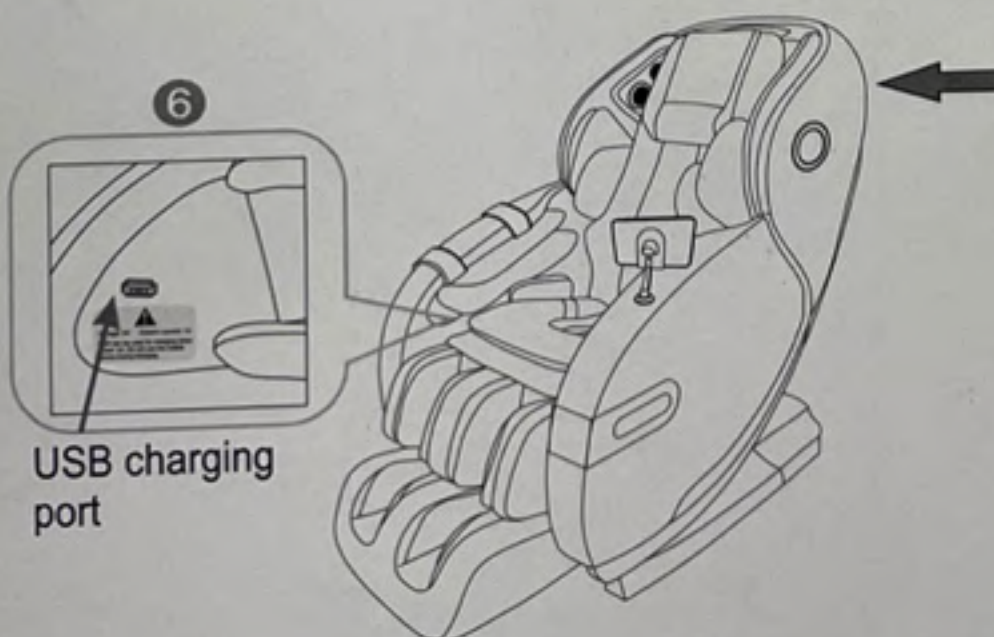

6 USB charging port

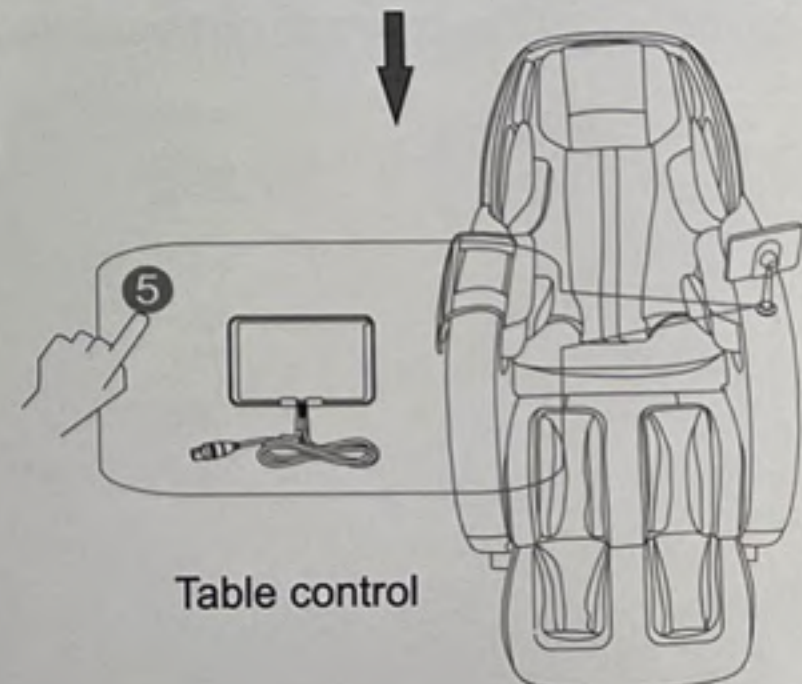

5 Table control

## Environment

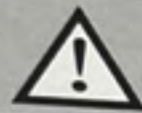

## Caution



Don't use the chair in wet places like near swimming pool, bath room to avoid leakage or electric shock.



Don't use under sunlight or near stove or other heating place to avoid upholstery deteriorated.



Please use chair in flat place to avoid chair falling or noise or other unexpected trouble.

## ● Check places in front

Check the areas when back and leg extending, make sure no people, pets or other things around.

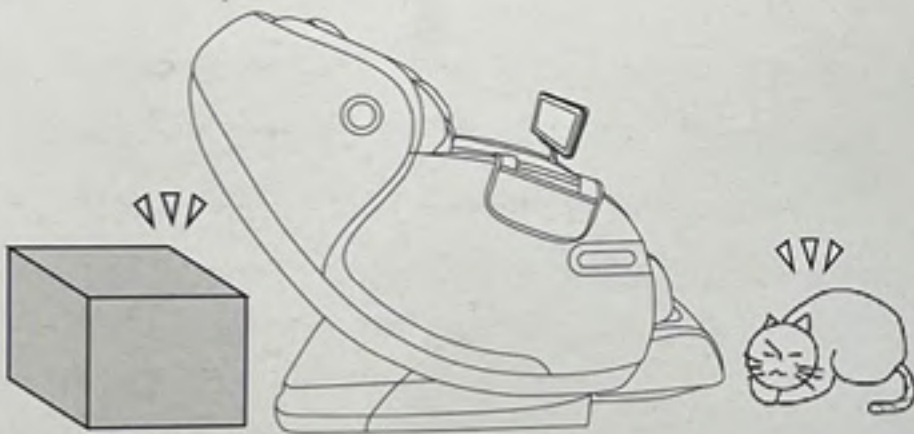

## ● Check power cable, plug

(1) Clean the dust on plug on time.  
(using dry cloth).

(2) No damage, re-do, bend, stretch, tie or press with heavy thing (especially can't be pressed by the chair) on power cable.

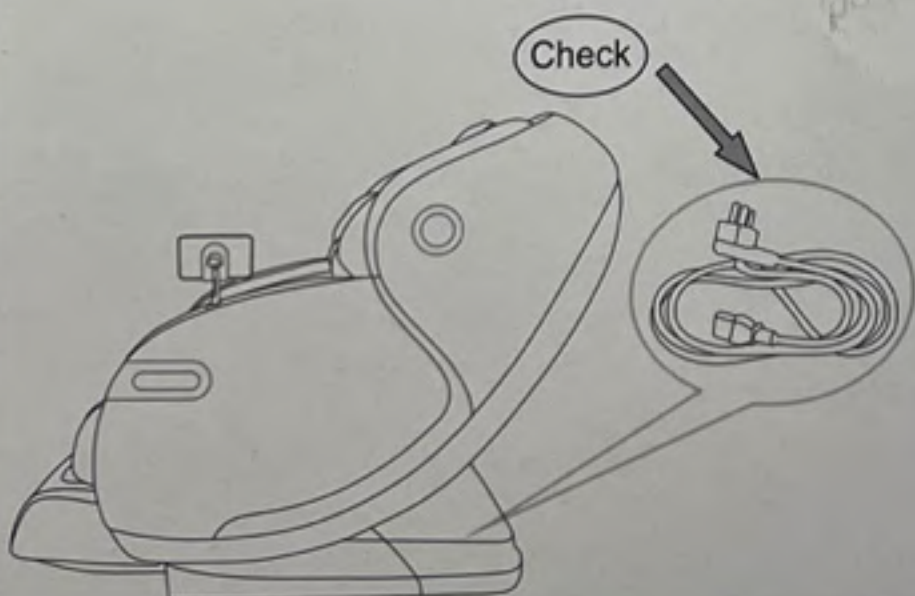

## Check environment

## ● Space size for using the chair

- At least 10cm from wall.

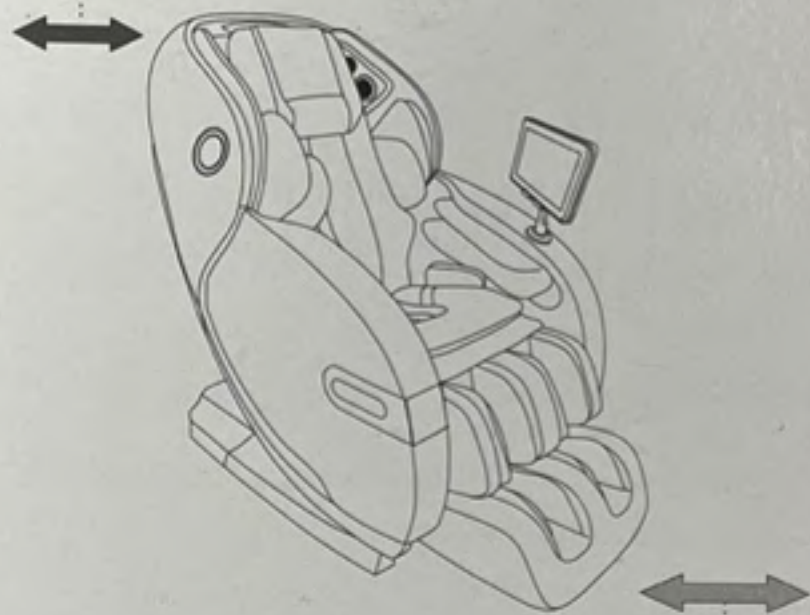

- At least 60cm in front of the leg.

## ● Check surroundings

When the backrest or legrest reclines or extends, please pay attention to:

- (1) Check any person or things in every direction.
- (2) Check the space size.

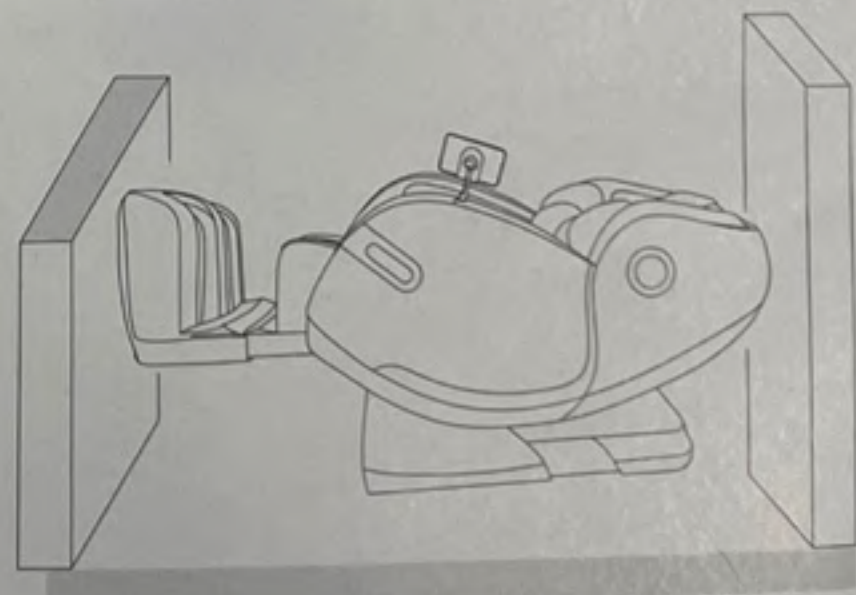
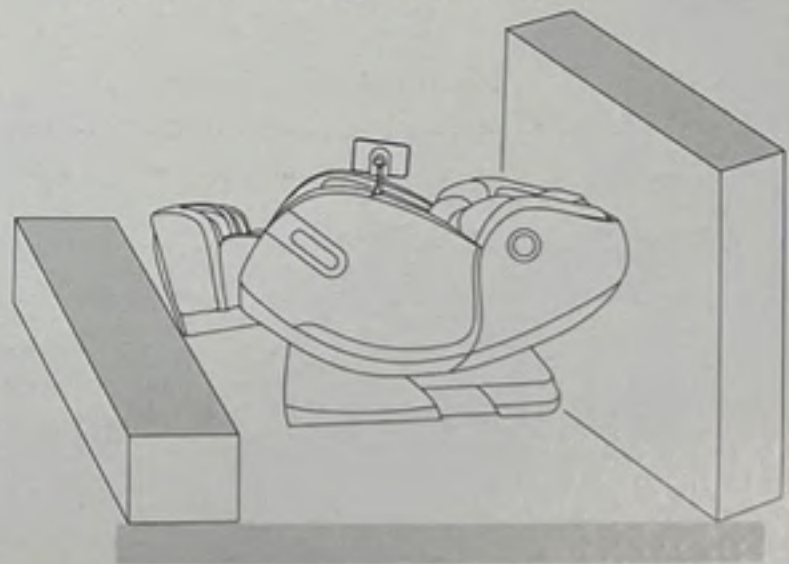



## How to move massage chair



### Caution

- ✦ Don't move chair when it's working in case of accidents or damage

### How to move

- ✦ Bind the cables and put them in the seat to avoid damage when moving.
- ✦ If you plump the chair, it may damage the inner parts of the chair.
- ✦ Don't use the castor if the floor is wooden or other easy damaged material. It will need 2 or more persons to lift the chair.
- ✦ Make sure the power is off and the plug doesn't touch the floor (It's better to let the chair in standing status to avoid the back crashing the floor)



### Normally

- 1 Press down the head part to make the gravity fall on the back castors. Then push the chair to desired destination steadily and set it down slowly.



No more than 40 degrees Rolling Wheel



Please hold the footrest to move the chair as shown in the picture in case any scratches on the leatherette

During massage chair backrest lie down process, can't move the armrest.

## Adjustment before massage

### ● Before adjustment

- ✦ Make sure the massage machine rollers stop in the upper of backrest, then sit on the chair slowly.

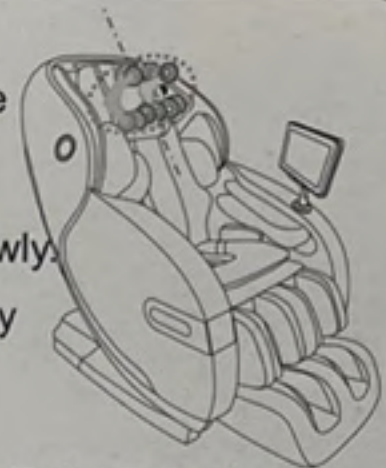

- ✦ To avoid injure caused by wrong position of the massage head.

- ✦ When doing Acupuncture Point Detecting, if the massage head can not find the shoulder position, it will default to the middle part.

**Right position:** Your back cling to the chair back, the head clings to the pillow.



The remote controller will hint once the body scan start to work, when you hear "beep sound", you can press the up/down key on the controller to manually adjust the shoulder position.

- ✦ Avoid a wrong detection of your shoulder position which will influence the massage comfort.

### ● Kind suggestion

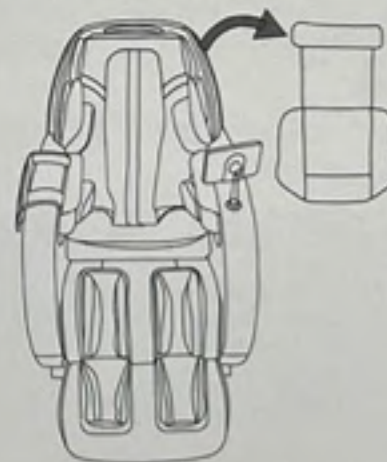

- If you feel the massage isn't strong enough, you can remove the pillow and shoulder cushion .

- Because the chair is heavy, it may ruin your floor in long time setting. Please put a blanket or other soft things to protect your floor.

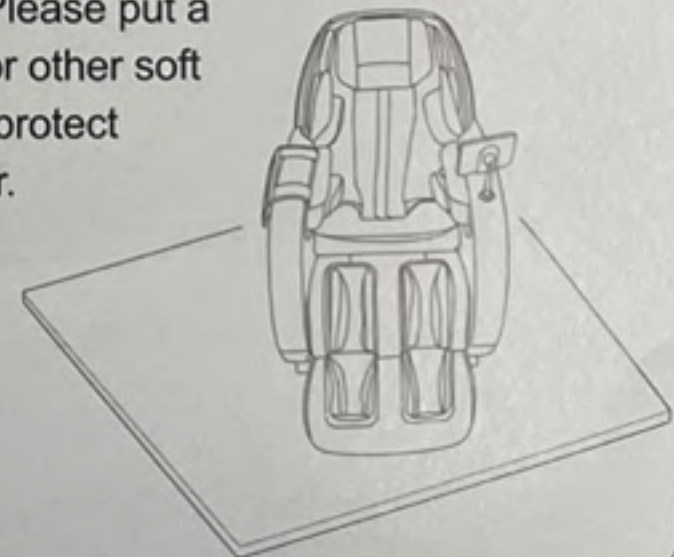

## Tablet Remote Control Operation

Top Face of Tablet Remote Control

Power Switch



Tablet Remote Control

LCD Touch Screen



1. After the chair is powered on, the tablet will turn on by default and display the boot interface. After a while, enter the main interface and press the power switch at the right end of the top face of the tablet to turn on/off the display of the tablet.



Main Interface I



On/Off

Demo

Health Care

Stretch

Pain relief

Navigation Icons  
Slide left and right  
to switch the main  
interface.

## Tablet Remote Control Operation



In the ON status, press this icon to enter Demo mode, default working time for this auto program is 8 minutes.

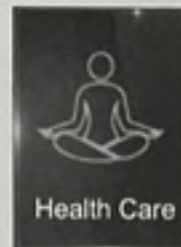

In the ON status, press this icon to enter health mode, default working time for this auto program is 20 minutes.

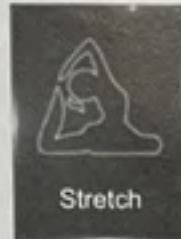

In the ON status, press this icon to enter stretch mode, default working time for this auto program is 20 minutes.



In the ON status, press this icon to enter the pain relief mode, default working time for this auto program is 20 minutes.

### Main Interface I

Demo, Health, Stretch and Pain relief interface



Massage operation



"Return" Press this button, return to the home page.



Press Power button, it turned to Pink color and massage function can be used normally



Stop icon, press this icon, the massage will stop, and remote screw back to main interface.



Press Pause button, massage function stopped, and change to this button. Press this button again, massage function re-start



"Knock" massage method status display.



"Knead" massage method display.



"Tap" massage method status display.



"Shiatsu" massage method display.



"Heating" is off by default. Press this button to turn on Heating function.

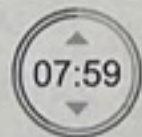

Massage time left and adjust button, shows the time left for the current massage function. Up and down arrow key can add or reduce the time.



Roller speed adjustment, has fast and slow two levels.



Adjust air pressure strength by this button with 4 levels.



Position adjustment button, click and enter the position adjustment interface.



Body massage position, ( screen can show the air massage, roller massage, heating status )

## Tablet Remote Control Operation

Positon adjust interface

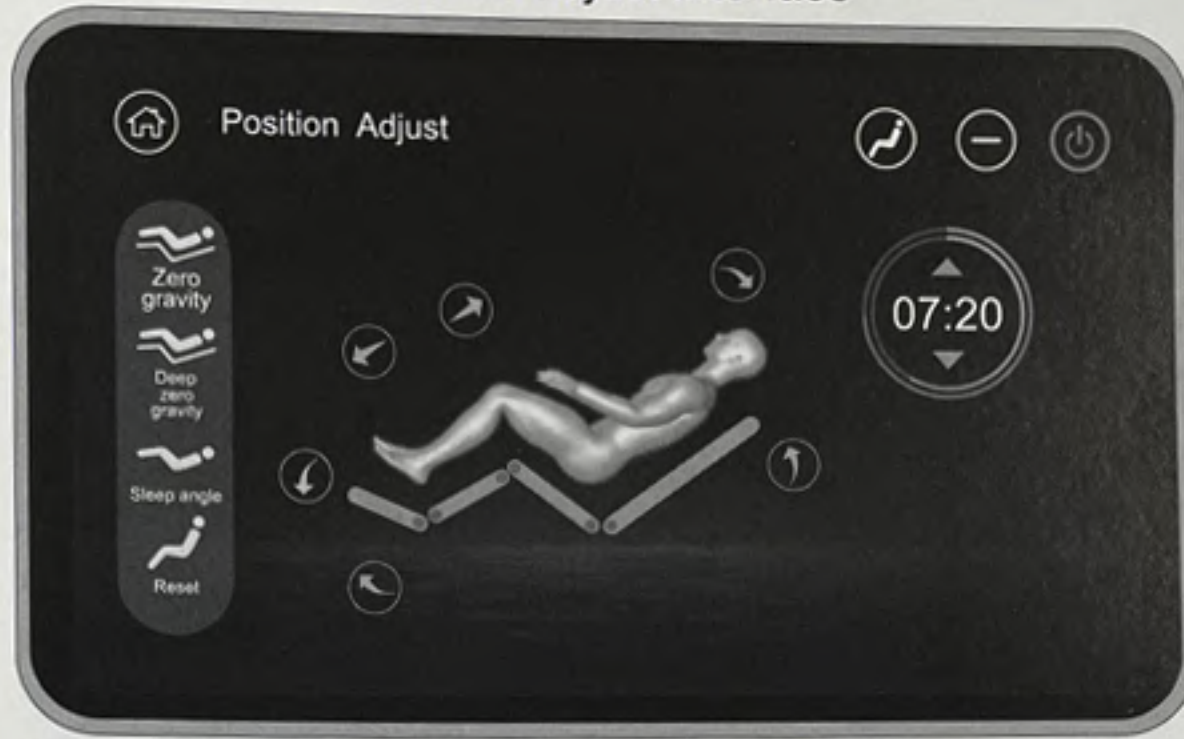

Zero gravity icon, click it to light to enter into the zero gravity function, the back will lie down, and the legrest will rise up.

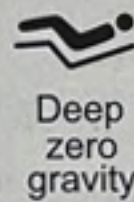

Deep zero gravity icon, click it to light to enter into the deep zero gravity angle, the backrest lie down, and the legrest rise up.



Sleep angle icon, click it to light to enter Sleep angle into the sleep angle, the backrest lie down, and legrest rise up

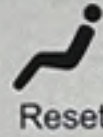

"Press "Rest" button, it tured lighter,function started, back part rising and leg & foot part recover to normal.

Massage operation

Legrest retract

Legrest extend

Legrest down

Legrest up

Backrest downward and legrest upward

Back rest upward and legrest downward



## Tablet Remote Control Operation

### Main interface II



On/Off

Navigation icon, slide left and right to switch interface.

Relax      Special Massage      Manual Massage      Others



In the ON status, click it the icon lights up, enter into the relax massage mode, the default working time is 20 minutes.



Relax Interface



In the ON status, press this key to enter Special Massage, 7 special auto programs for your option. (See Special interface introduction for details).



Special Massage Interface



In the ON status, press this key to enter Manual program interface. (See Manual interface introduction for details).



Manual Massage Interface



In the ON status, press this key to enter Personal Center interface. (See Personal Center interface introduction for details).

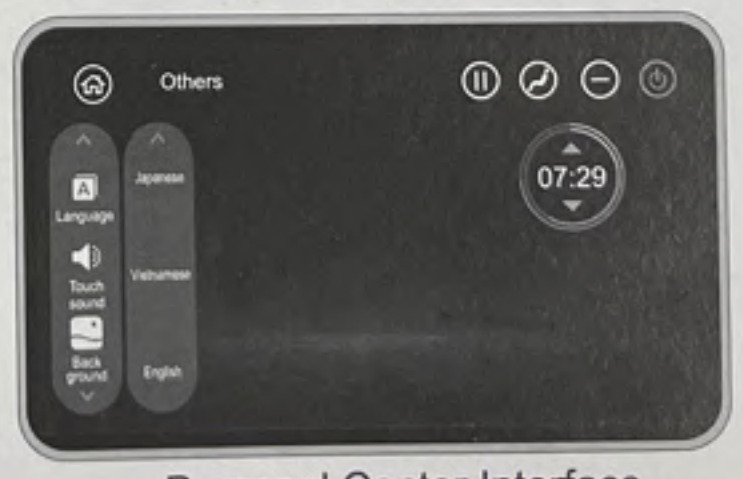

Personal Center Interface

Message operation

## Tablet Remote Control Operation

### Main interface II Special Massage



Special Massage Display Area

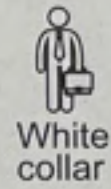

White collar

In the ON status, after clicking this button, the icon lights up, the "White Collar" is turned on.



Shopaholic

In the ON status, after clicking this button, the icon lights up, the "Shopaholic" is turned on.

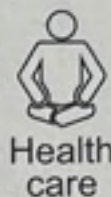

Health care

In the ON status, click it the icon lights up, the "Health care" is turned on.

Massage operation



Music sync

In the ON status, after clicking this button, the icon lights up, the "Music Sync" is turned on.



Longevity

In the ON status, after clicking this button, the icon lights up, the "Longevity" is turned on.

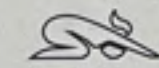

Yoga back

In the ON status, after clicking this button, the icon lights up, the "Yoga Back" is turned on.



Athlete

In the ON status, after clicking this button, the icon lights up, the "Athlete" is turned on.

### Main interface II Manual Massage Interface



Manual Massage Display Area

Mode Display Area



Mode

In the ON status, after clicking this button, the icon lights up, one menu will pop up and display Knocking, tapping, kneading, Shiatsu, knead&tap five kinds of massage technique.

## Tablet Remote Control Operation

### Main interface II Manual Massage Interface

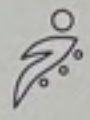

Manual Massage Display Area    Mode Display Area

 Position  
When Power on, press this button and the menu of parts will showing: whole body, shoulder, back, waist, seat and fixed point; press "fixed point" button, it will show up and down button, you can adjust the upper and lower back massage position. Press Position again, the tablet will get back to this interface again.

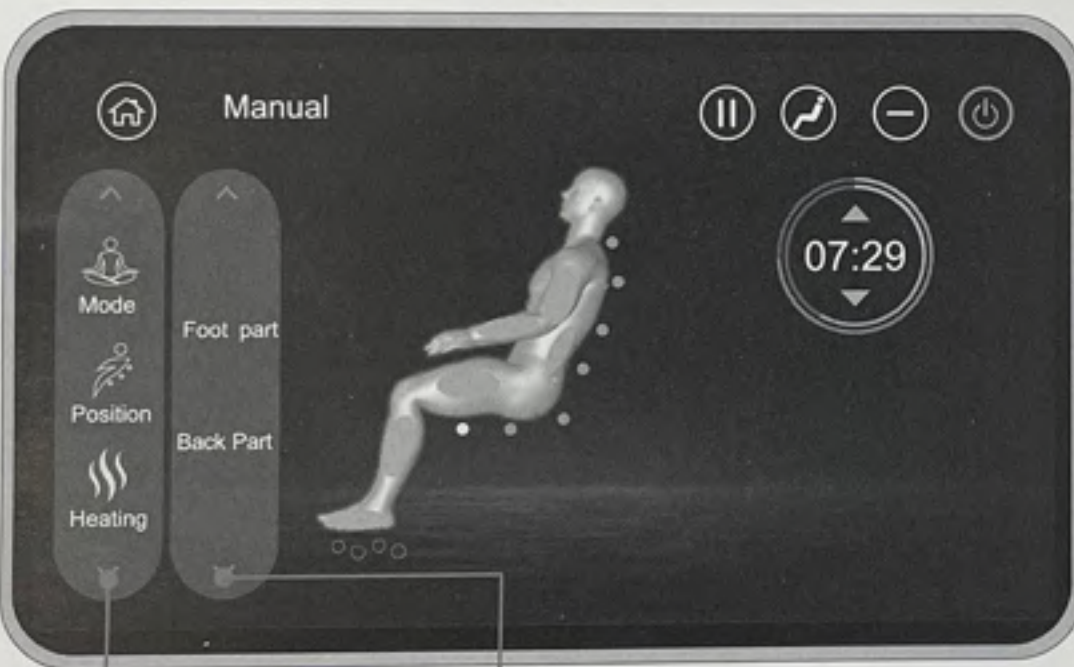

Manual Massage Display Area    Mode Display Area

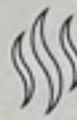
 Heating  
When power on, press this button and it will appear the menu showing "Foot parts" and "Back Part". Press the button of each part to turn on/off the heating function.

Massage operation

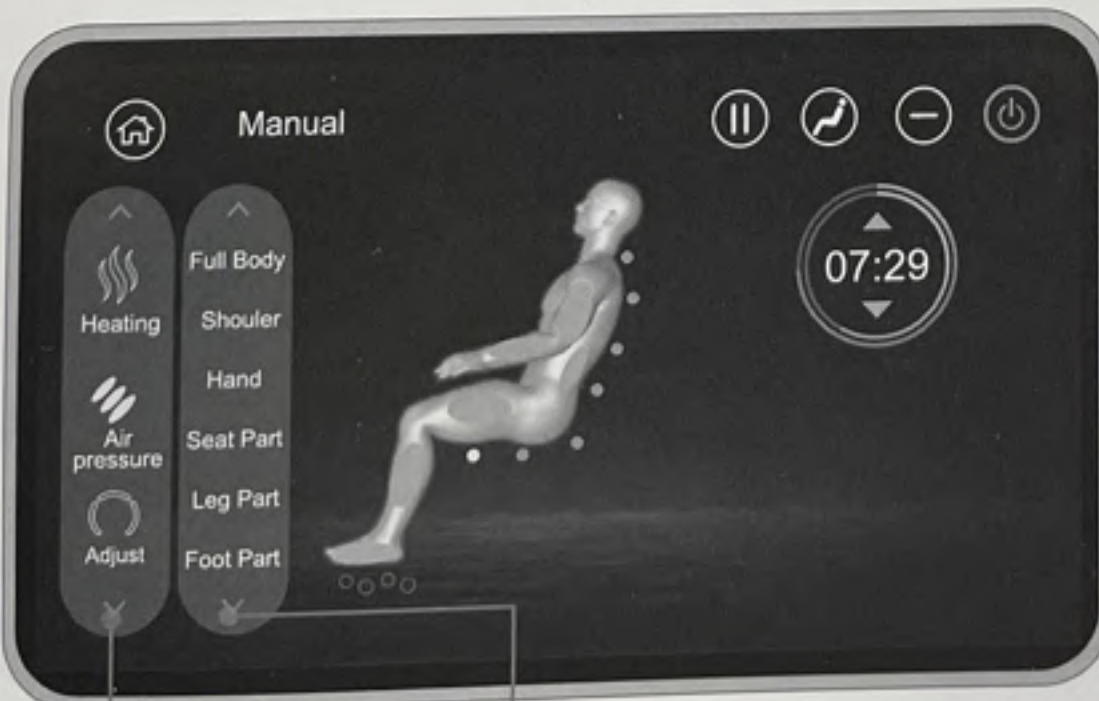

Manual Massage Display Area    Mode Display Area

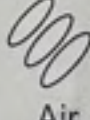
 Air pressure  
When power on, press this button and it will appear the menu showing Full body, Shoulder, Hand, Seat Part, Leg Part, Foot Part button, press one of these buttons, the air pressure massage will be started.

## Tablet Remote Control Operation

### Main interface II Manual Massage Interface

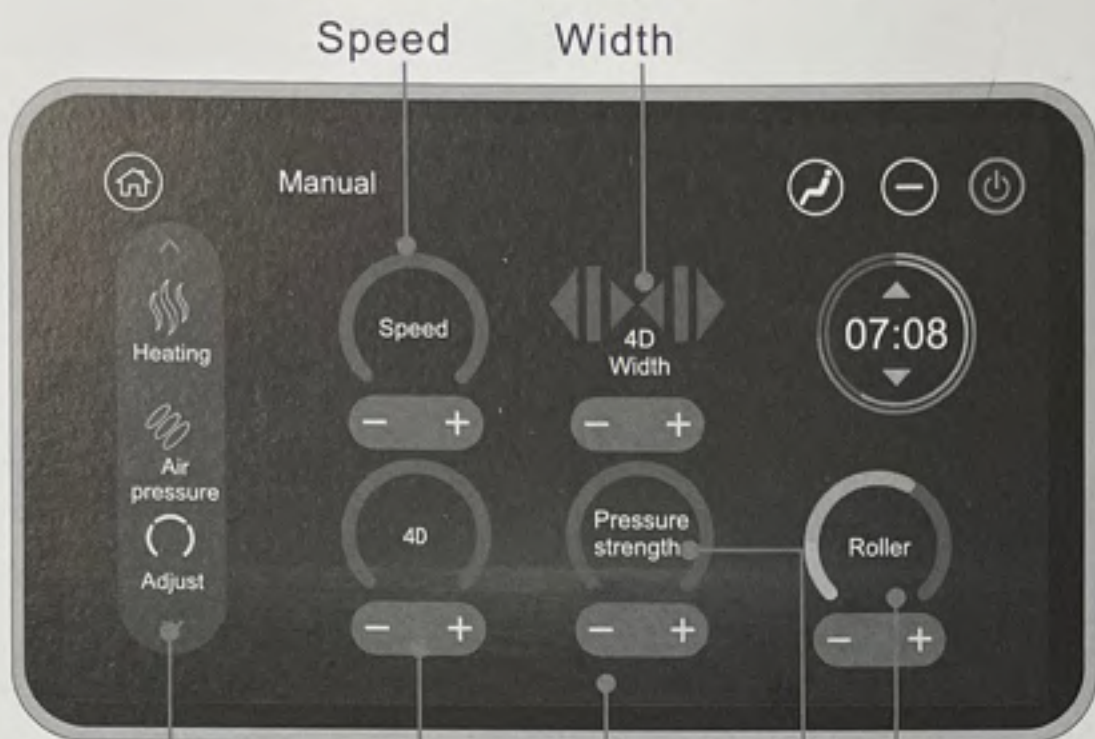

Manual Massage Display Area  
4D Adjustment  
Adjustment Display Area  
Air Pressure Adjustment  
Roller Speed Adjustment

 In the ON status, click the icon Adjust lights up, finger touch slide from left to right, to adjust the "speed" "4D width", time, 4D, pressure trength, roller speed. 4D has 4 level, width 3 level, roller speed 2 level. Click the "+", "-" to adjust.

Massage operation

### Main Interface II Personal Center Interface

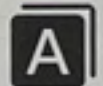

Personal Center Display Area

 When power on, press this button, it will show three languages: Japanese, Vitnamese and English.



Personal Center Display Area  
Mode Display Area

 In the ON status, click this icon to light up, to open or close the touch sound.



## Tablet Remote Control Operation

### Main Interface II Personal Center Interface

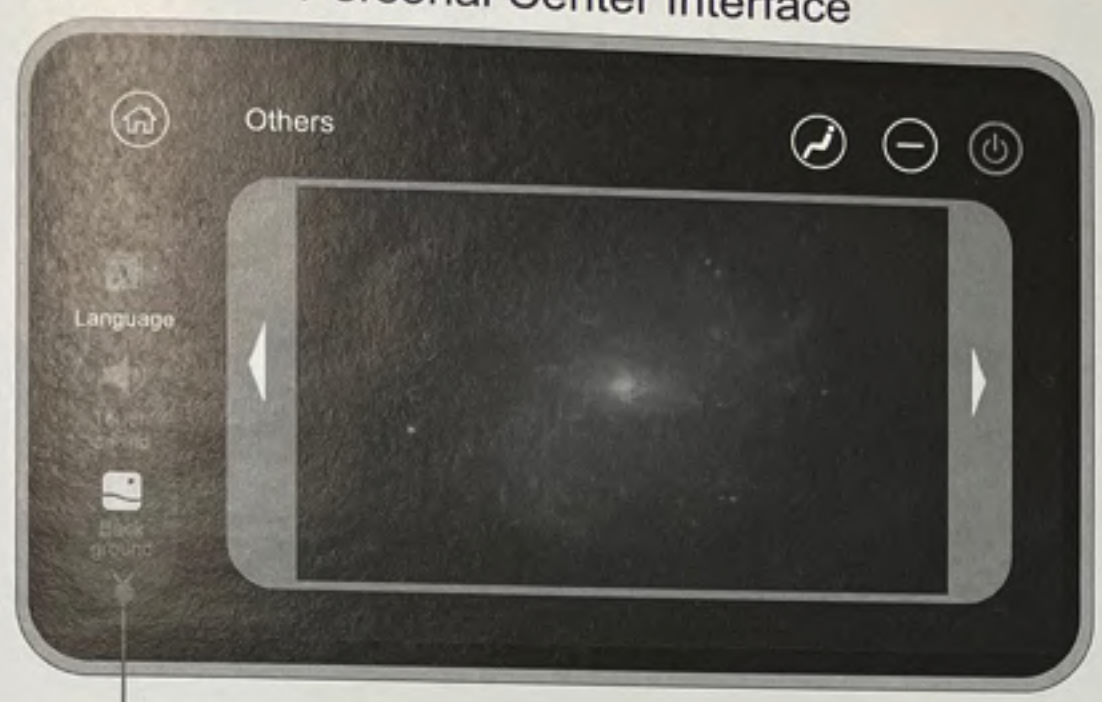

Personal Center  
Display Area

 When power on, press this button, it will show background interface, you can choose background accordingly.

### Body Scanning

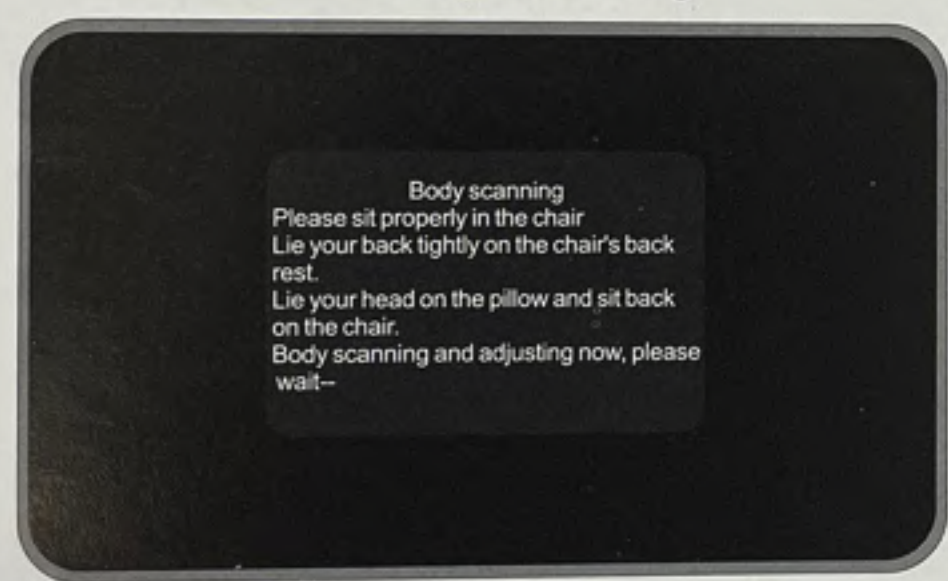

### After Body Scanning ,it will show this interface

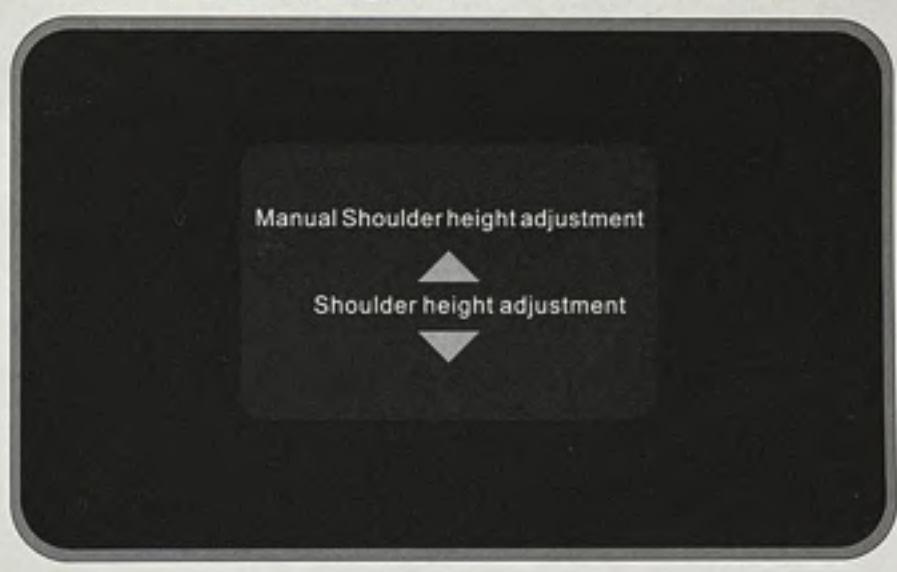

Massage operation

## Voice control using method

## Voice control using method

In the standby state, press the power switch of remote control to enter the power-on state, and then the voice recognition system enters the waiting state.

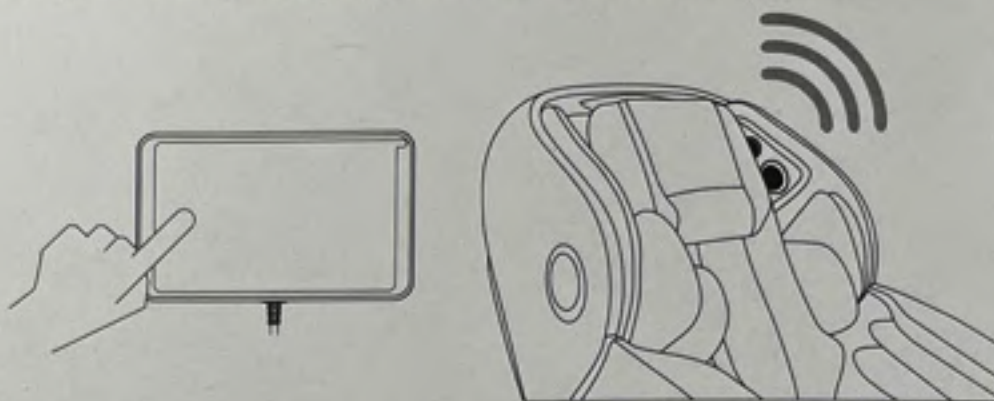

- When using speech recognition function, it is necessary to speak the wake -up word " turn on speech recogni tion mode " system to recognize the subsequent speech and voice control entries. After turning on the voice mode , the system will automatically turn off the voice mode if the voice command is not spoken within 20 seconds.
- After the massage chair recognizes the entry of voice control, there will be corresponding speaker voice feedback, indicating that the command recognition is successful. If there is no corresponding speaker voice feedback, the command recognition is unsuccessful or the current state does not support this function.
- Voice control words:  
Wake up word: "Hello Eve"  
1. "Massage chair shutdown" 2. "Health Care" 3. "Pain Relief" 4. "Stretch"  
5. "Yoga Back" 6. "Athlete" 7. "Relax" 8. "Zero Gravity Start"

## ON/OFF

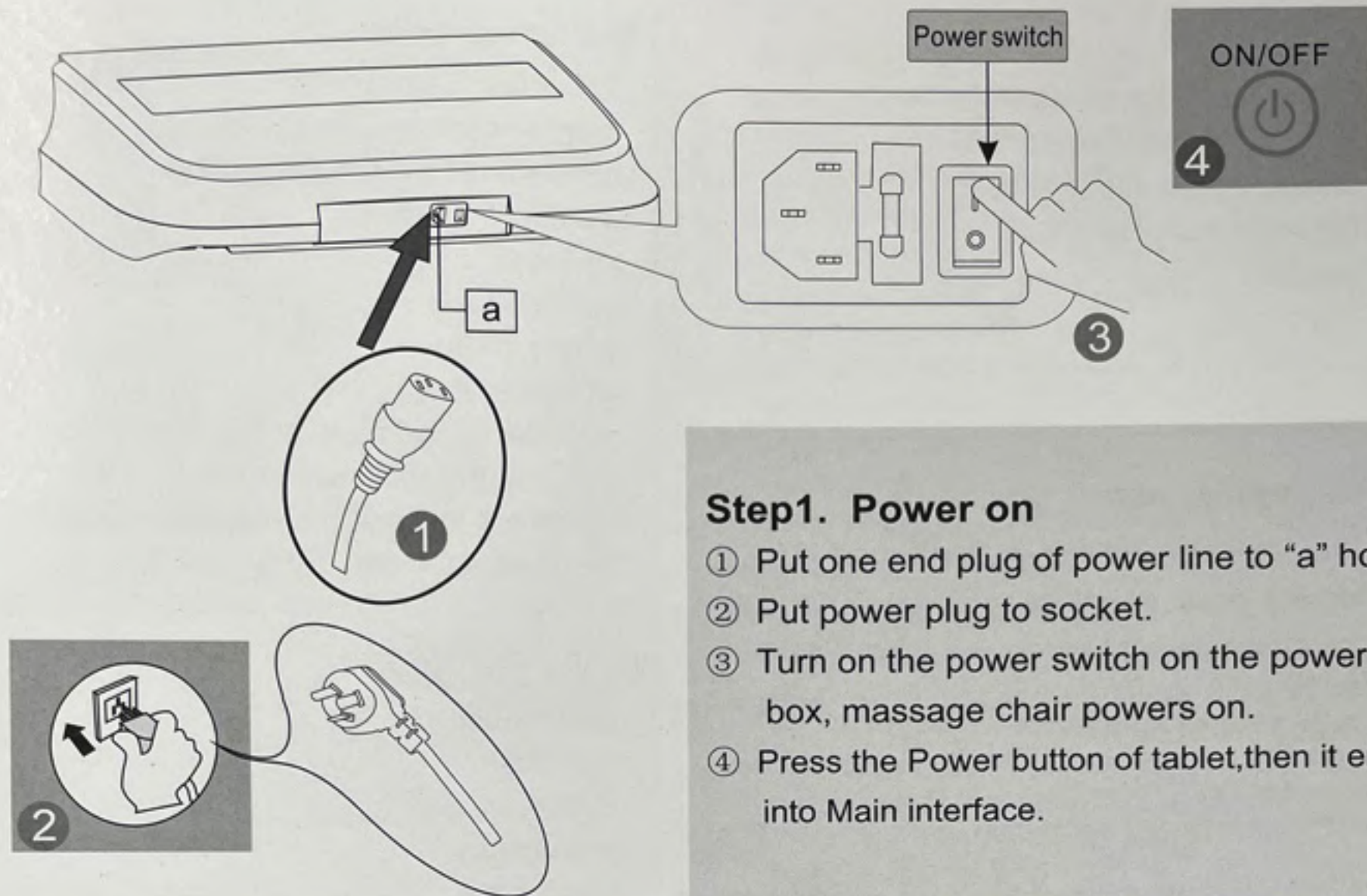

### Step1. Power on

- ① Put one end plug of power line to "a" hole.
- ② Put power plug to socket.
- ③ Turn on the power switch on the power box, massage chair powers on.
- ④ Press the Power button of tablet, then it enter into Main interface.

### Step2. Massage

- ① Please operate according to above Tablet Using Method and choose the suitable function.
- ② When massage finished, the chair recover to normal status, and the tablet control's Power button become to white color.

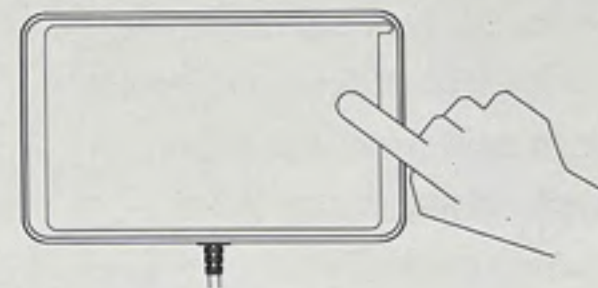

Tablet Control

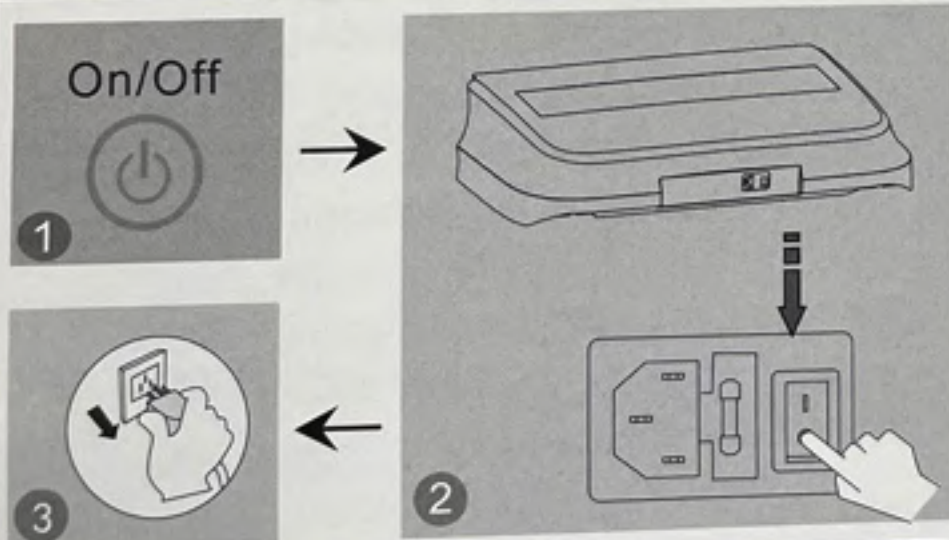

### Step3. Turn off the power

- ① When the chair is On, Tablet Control press On/Off button to turn off the massage chair and it will restore automatically.
- ② Turn off the power switch on the bottom of the back of chair after the rollers reach storage position.
- ③ Unplug the power plug from the socket.



**Warning**

1. Before using, pull up the pillow, back cushion etc. to check if the PU material is broken, if there is damage, please stop using, unplug the chair, and ask for repairment.
2. Only plug to proper socket.

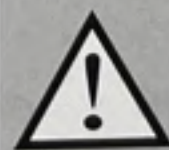

**Attention**

1. Before sitting down, make sure there is no things pinched between armrest, legrest, backrest and seat of the chair.
2. Foot-rest is equipped with safety protection device, if there is any obstacle between the leg and foot, foot-rest will stop retraction automatically.
3. Make sure the chair is in reset state before using.
4. Do not stand on it when using the massage chair.

## Function Illustration

## ● Legrest Up

Press this button on controller, legrest goes up. Release the button, legrest stops moving, the angle is locked in this position.

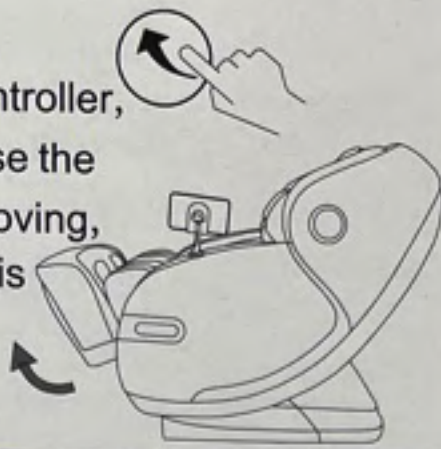

## ● Legrest Down

Press this button on controller, legrest goes down. Release the button, legrest stops moving, the angle is locked in this position.



## ● Legrest up and backrest down

Press this button on controller, backrest goes down and legrest goes up. Release this button, backrest and legrest stops moving, the angle is locked in this position.

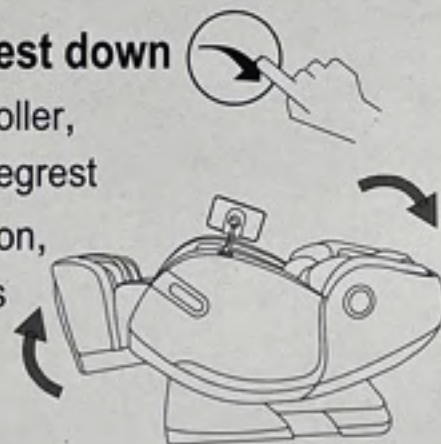

## ● Backrest up and Legrest down

Press this button on controller, backrest goes up and legrest goes down. Release this button, backrest and legrest stops moving, the angle is locked in this position.

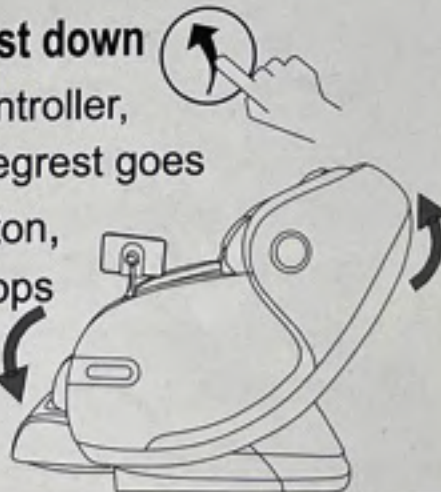

## ● Zero gravity

Press the "Zero Gravity" button on the remote control, the backrest will fall, the legrest will rise, and adjust the angle to achieve a comfortable zero gravity. It can effectively relieve the pressure on the spine and joints. Press this button again, the backrest will rise, the legrest will fall, and the angle will return to the power-on state.

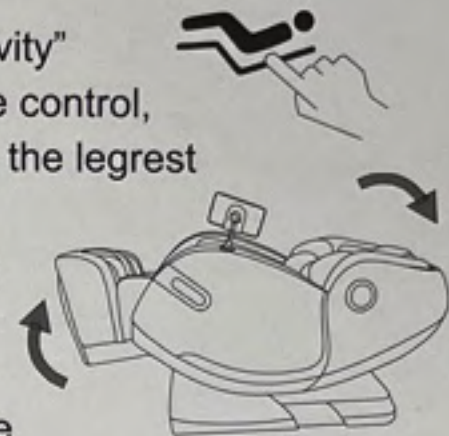

## ★ Tips: Zero-gravity

is according to the NASA

Space capsule relax theory,

through the

back, seat,

legrest three

sections multi

angle changeable,

making the legrest up and seat down can

make the angle 128 (+/-7) degrees between

Body and legrest..let the heart and knee at

the same level, reducing the blood circulation

pressure to the lowest, but all the body

pressure will put on the buttocks, And

because of the ZERO GRAVITY position

design, increase the forced area from the

body and massage chair, so all the forces

can be dispersed to the massage chair,

reducing heart and spine pressure, realizing

the best Zero gravity massage experience.

creating a completely relax, natural and

comfortable massage posture.

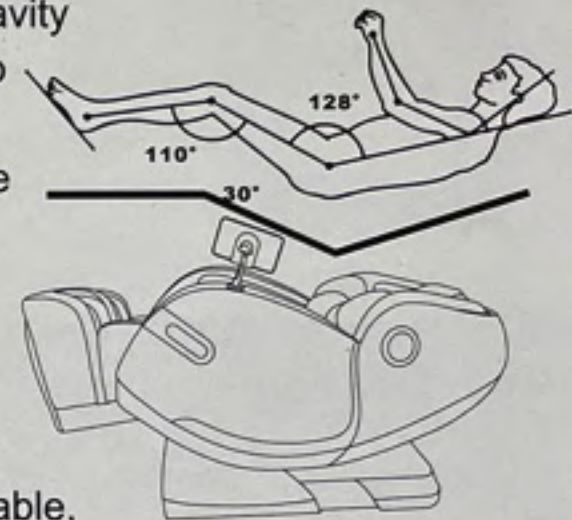

1. Please make sure there is no people, no pets or any stuff around the backrest to avoid unexpected hurt or property loss.
2. When adjusting the backrest, be careful of the gap between the backrest and armrest.
3. When the legrest is moving, please do not stand on or leave from the seat, do not stop the legrest from moving in case of causing damage to the chair.
4. Please refer to control instruction for more details.

## Function Illustration

### ● Legrest extend and retract

Legrest can extend and retract within 20cm automatically.



### ● Arm massage

Massage chair use space capsule type armrest, with built-in pulse air pressure massage function. Put the arms between armrest's air bags. After filling air, achieve kneading massage on the arms and hands. The arms could get comfortable massage in any angle of the chair.

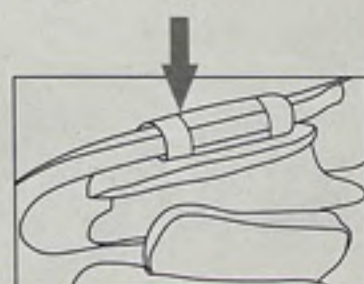
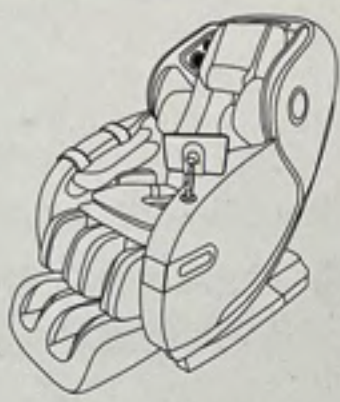

### ● Shoulder massage

Multi-layer exposed airbags are located on both shoulders to assist with stretch function. The 4D massage rollers push forward your body, while the airbags grip your shoulders to provide the ultimate full body stretch.



### ● Warm foot therapy

Innovatively developed two-way rotary foot kneading technique, realizing the sole function of kneading foot, combining with foot heating, it can perform best foot massage experience, good for health.

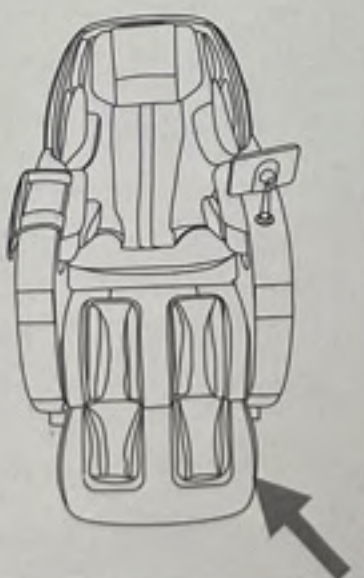

### ● New Curve rail, Combination of back and buttocks massage.

Massage chair adopts 4D curved rail technology, combining with 4D massage mechanism patent, realizing multi-angle integrated massage for back and buttocks.

It has broken through traditional L shape rail's function which can't realize lying flat and stretching, and achieve best massage effect.

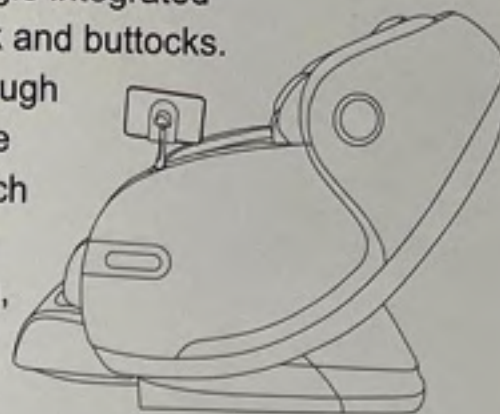

### ● Music therapy

There are multiple speakers surrounding the headrest. The blue-tooth wireless music player can integrates music into the massage techniques with synchronic therapy, which allow the rollers to massage you to the beats of your music. Relaxing to your own tunes will improve your blood and ease fatigue.

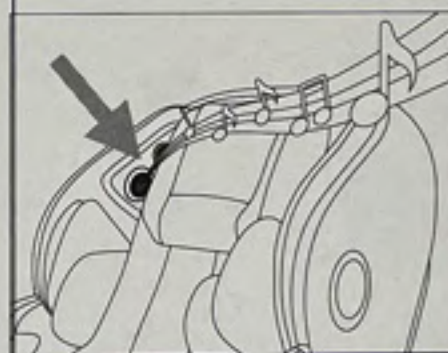

## Restoration of massage chair

- ① Make sure there is no people or pet or anything within the range of backrest and legrest.

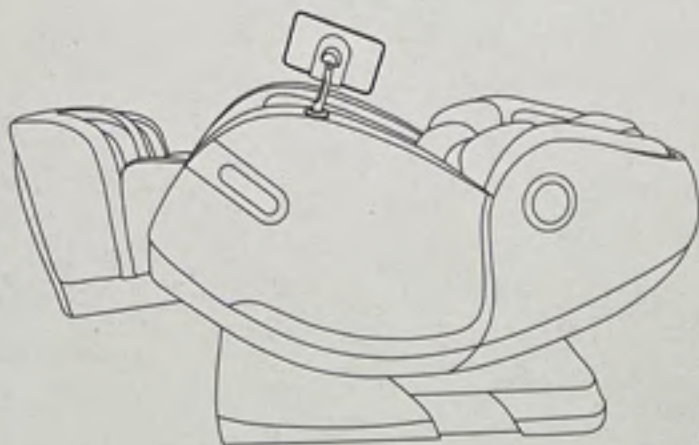

- ② Make backrest and legrest restore to the normal position by controller. (or press ON/Off key to make backrest and legrest restore to the normal position)

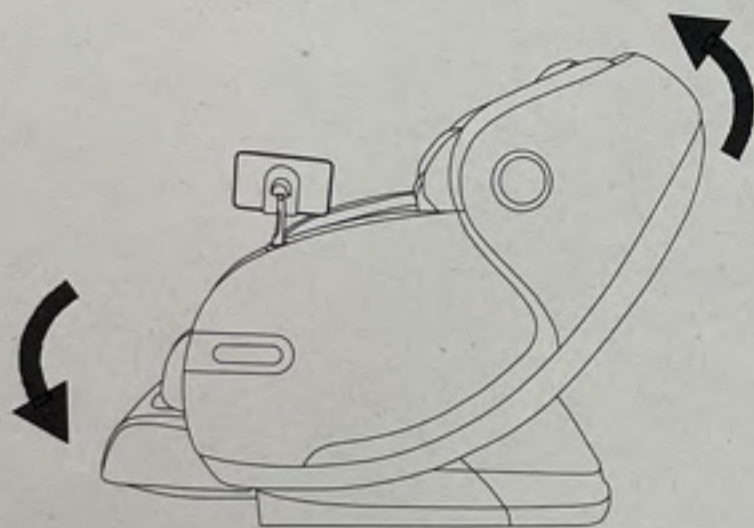
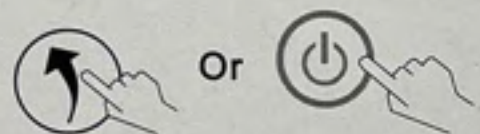

- ③ After chair returns to the upright position, store the controller in the pocket on the left armrest.

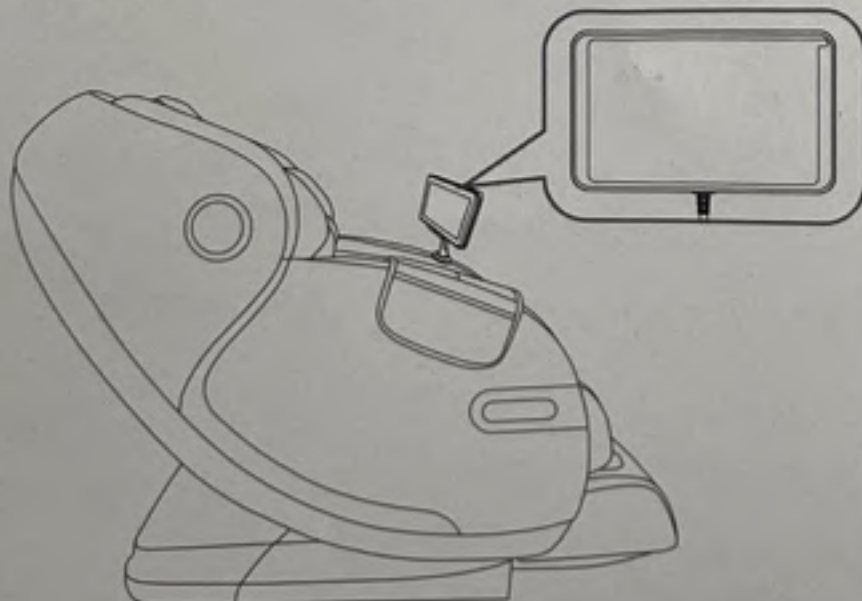

- ④ Switch off the power.

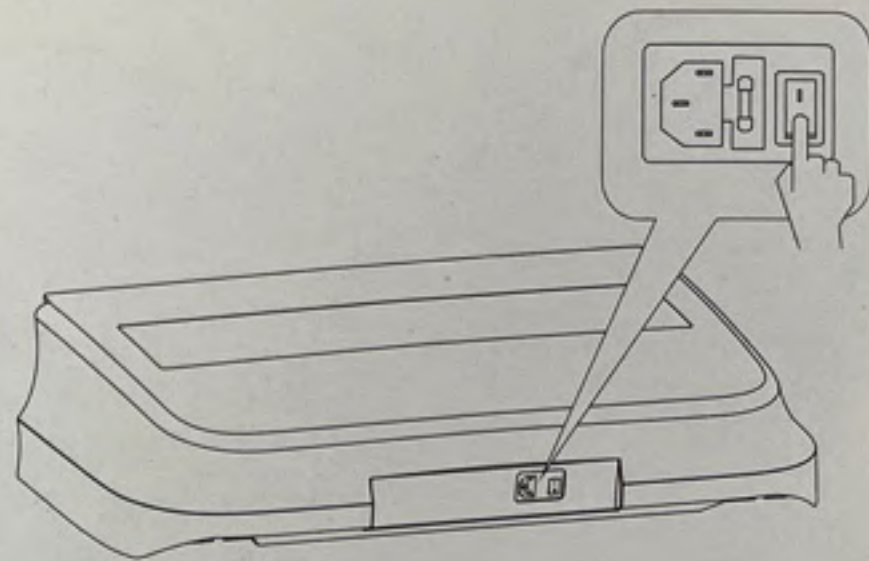

- ⑤ Unplug the electricity from the socket. (Attention: hold the right plug position)

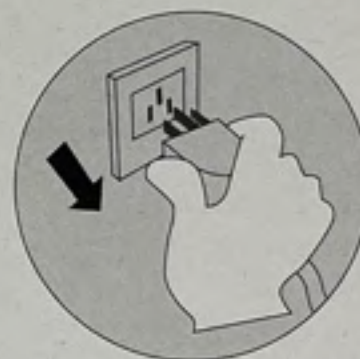

- ⑥ Clean the chair if necessary.

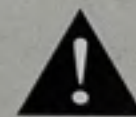

## Attention!

- After using, press ON/OFF to end all the massage method and wait for restoration. Make sure to cut the electricity to avoid any unexpected hurt to children or pets.
- After using, turn off the power, unplug the electricity. Avoid moisture, dirt and aging of insulation in case of causing damage.

## Synthetic leather

### ● General cleaning

Clean with tidy, soft and dry cloth slightly.



Do not use the thinner, gasoline, alcohol or other chemical materials.



### ● If leather is dirty

- ① Dip soft cloth into 3-5% neutral detergent solution, squeeze it then clean the stain on the surface gently.
- ② Wash cloth, squeeze it and wipe with detergent.

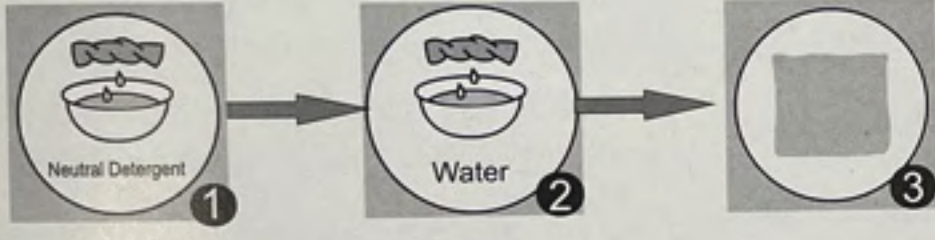

- ③ Clean it softly with dry cloth.
- ④ Allow to dry (air blower is prohibited)

## Plastic parts

- ① Dip cloth into neutral detergent, squeeze it and clean.
- ② Wipe with water-dipped but squeezed cloth.
- ③ Allow to dry.

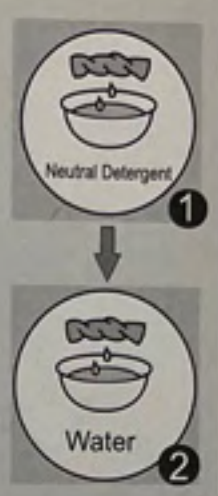

## Clean the controller

- ① Wipe with soft cloth after squeezing.
- ② Allow to dry.

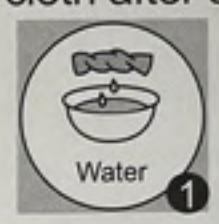

Do not use the thinner, gasoline, alcohol or other chemical materials.



Tablet Control

## Cloth material

- ① Dip cloth into weak neutral detergent, squeeze it and clean the material surface.
- Do not use the thinner, gasoline, alcohol or other chemical materials.

- ② Brush the dirty parts with weak neutral detergent. (avoid excessive brushing)

※ Excessive cleaning may cause damage to cloth material.

- ③ Wipe with water-dipped but squeezed cloth.

- ④ Allow to dry.



### About cleaning

- Before cleaning, unplug the electricity, don't touch plug with wet hands.
- Make sure hands are dry when plugging to the socket.
- If failed to follow the mentioned instruction, user may get electric shock or burned.

## FAQ and Troubleshooting

Trouble	Possible reason	Troubleshooting
The massage chair can't work after power is on.	Check if the control is on or not.	Open control switch
	Not choose massage function	Choose massage function
	Check whether the plug and socket in poor contact.	Make sure plug and socket are connected.
	Wire or plug has damaged.	Please ask manufacturer or appointed or authorized maintenance man for checking and replacement.
	The fuse burned out.	Replace fuse of same specification.
	Something wrong with inner circuit	Please ask appointed or authorized maintenance man for checking and repairing.
There is beep sound inside the massager while working.	It is sound of air pump, motor and mechanical parts.	Normal sound, no need to pay attention to it.
Different height of the left roller and right roller.	Massage rollers work on shifts.	Normal, no need to pay attention to it.
Sound suddenly becomes much louder while working.	Check if it is due to long time working.	Turn off the power to have the massager rest for over half an hour before next turn working.
	Inner parts fretted away due to long time work. It's normal	Please ask appointed or authorized maintenance man for checking and repairing.
Massage function suddenly stops while working.	Suddenly power-down	Connect the electricity power again
	Setting time is up.	Turn off the power to have the massager rest for over half an hour before next turn working.
Neither the backrest nor the legrest can be lay down.	Check if there are any obstacles; the chair overloads; for the sake of safety, sometimes the massage machine may automatically stop working.	Remove the obstacles; turn off the power to have the massager rest for over half an hour before next turn working.
The chair can't return to its original position.	Excessive operation; setting time is up.	Please ask manufacturer or appointed or authorized maintenance man for checking and replacement.
Electric wire or plug give out heat	It may work overload	Turn off the power to have the massager rest for over half an hour before next round working.
	Other abnormal case	Stop using, and ask appointed maintenance man for help.

Others

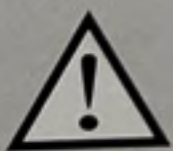

**Note:** If the troubles are not caused by above reasons, please turn off the power switch and cut off the power, then contact the manufacturer or service agent to repair your chair.



Technical data

Name	Massage Chair	Power	260W
Model	GF-500	NW/GW	Main body : 107/128.4kg Armrest : 17.5/22kg Legrest & footrest : 29/32.6kg
Input voltage	<input type="checkbox"/> AC120V, 60Hz <input type="checkbox"/> AC220V, 50/60Hz <input type="checkbox"/> AC240V, 50Hz		
Safety design	Class I	Packing size	Main body: 1575×805×965mm Armrest : 1025×400×760mm Legrest & footrest : 585×570×615mm (L×W×H)

Make your life healthy  
and beautiful every day!