



Instructions for Micro-Trak Seed Rate Control Systems Used with Trimble Controllers EZ Boom 2010 - Single Section

1. Install system components and harnessing per general instruction manual (Micro-Trak P/N 17632).
2. See attached system and wiring diagrams for Trimble EZ Boom 2010-specific harnessing. Note the different diagrams for single drive or multi-drive systems.
3. See page 10 for Calculating Flow Cal or Pulses per 1000 Seeds to be entered in the EZ Boom 2010 Application Rate Controller Program.

Single Drive Harness Kit System Diagram

OPTIONAL 5-PIN CABLES		
P/N 14482	5'	CABLE
P/N 14483	10'	CABLE
P/N 14484	15'	CABLE
P/N 14485	20'	CABLE
P/N 14486	25'	CABLE

OPTIONAL 10-PIN CABLES		
P/N 13220	5'	CABLE
P/N 13221	10'	CABLE
P/N 13222	15'	CABLE
P/N 13223	20'	CABLE
P/N 13224	25'	CABLE
P/N 14142	50'	CABLE

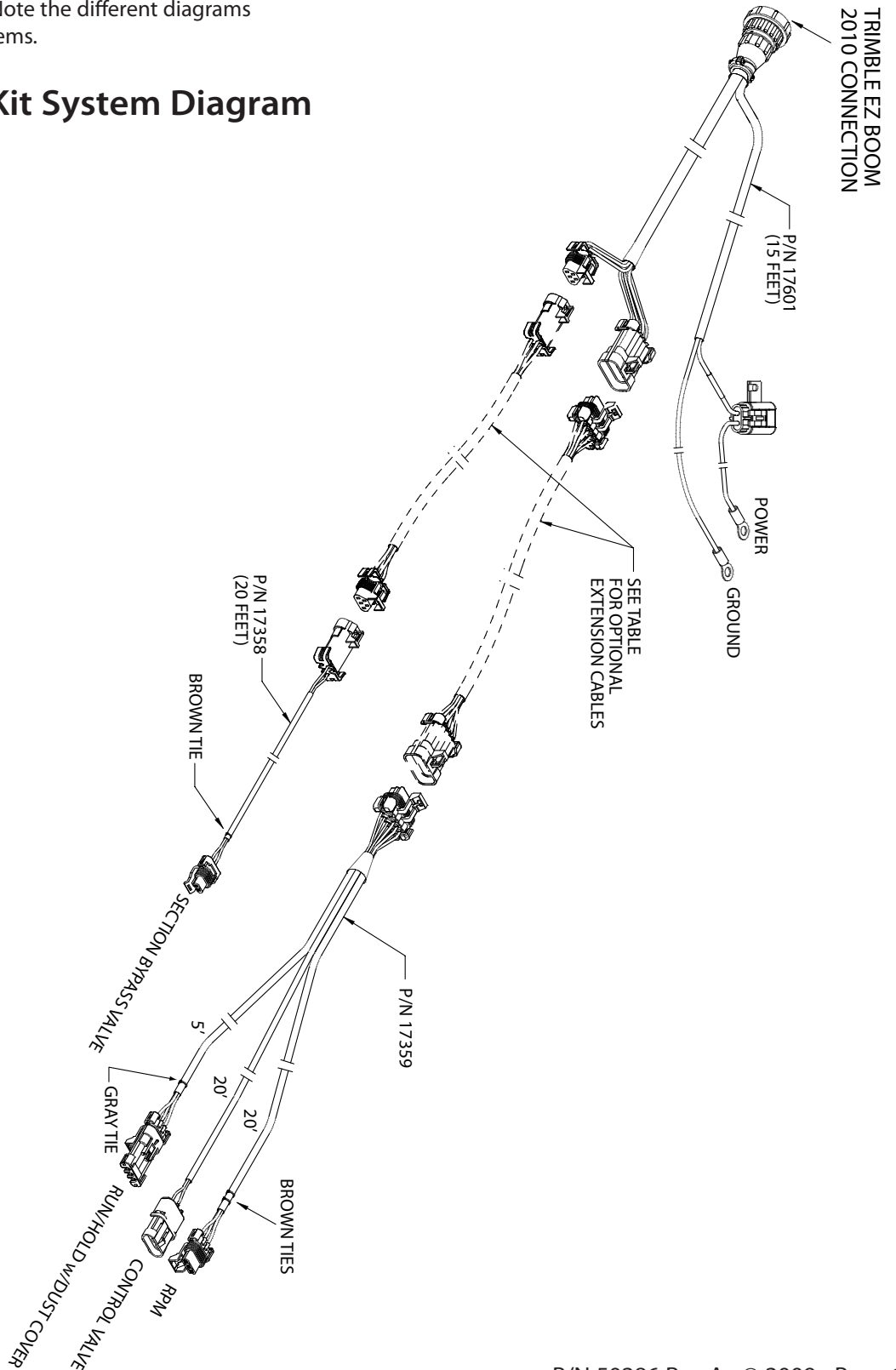



Three Drive Harness Kit System Diagram

OPTIONAL 10-PIN CABLES	
P/N 13220	5' CABLE
P/N 13221	10' CABLE
P/N 13222	15' CABLE
P/N 13223	20' CABLE
P/N 13224	25' CABLE
P/N 14142	50' CABLE

OPTIONAL 7-PIN CABLES	
P/N 14146	5' CABLE
P/N 14147	10' CABLE
P/N 14103	15' CABLE
P/N 14236	20' CABLE
P/N 14237	25' CABLE

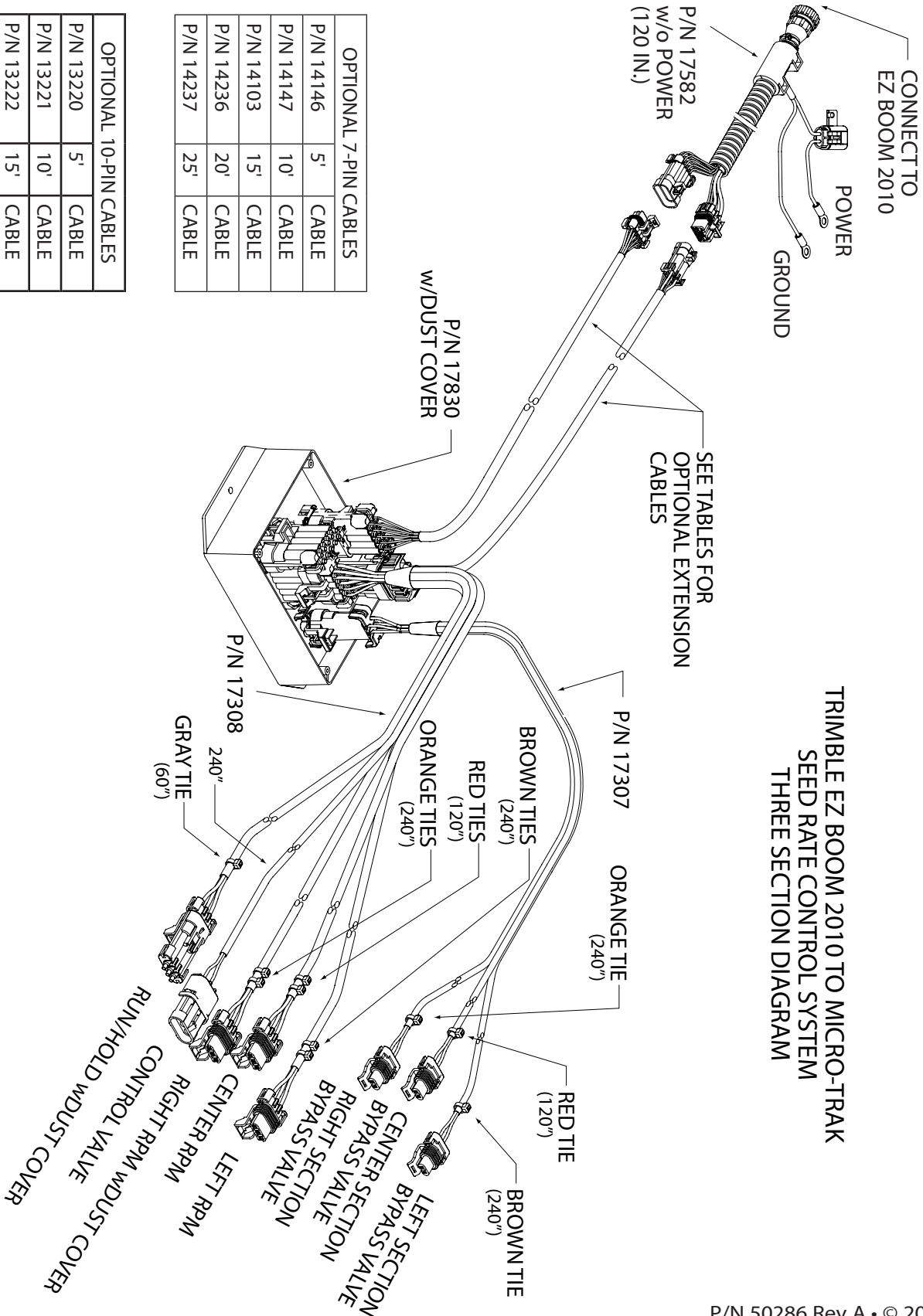



Three Drive Harness Kit Wiring Diagram

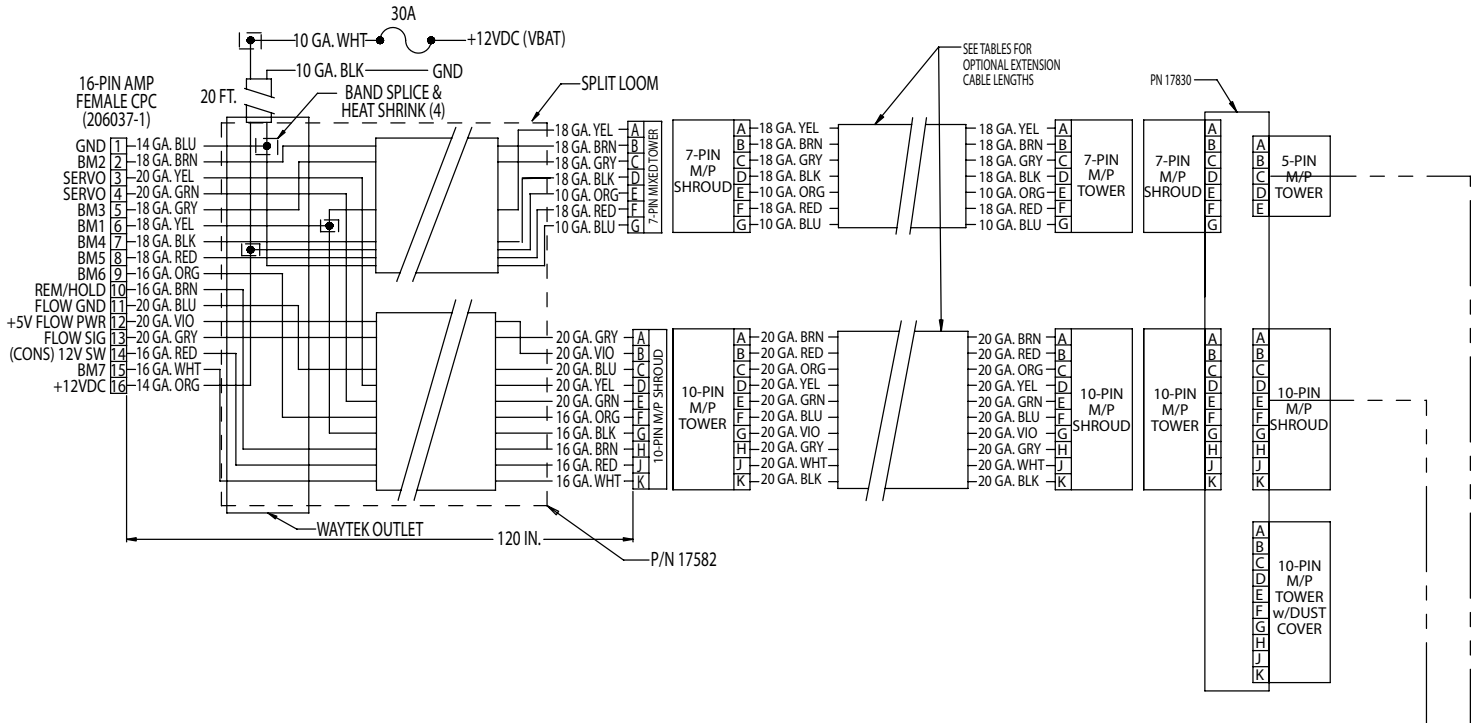

OPTIONAL 7-PIN CABLES		
P/N 14146	5'	CABLE
P/N 14147	10'	CABLE
P/N 14103	15'	CABLE
P/N 14236	20'	CABLE
P/N 14237	25'	CABLE

OPTIONAL 10-PIN CABLES		
P/N 13220	5'	CABLE
P/N 13221	10'	CABLE
P/N 13222	15'	CABLE
P/N 13223	20'	CABLE
P/N 13224	25'	CABLE
P/N 14142	50'	CABLE

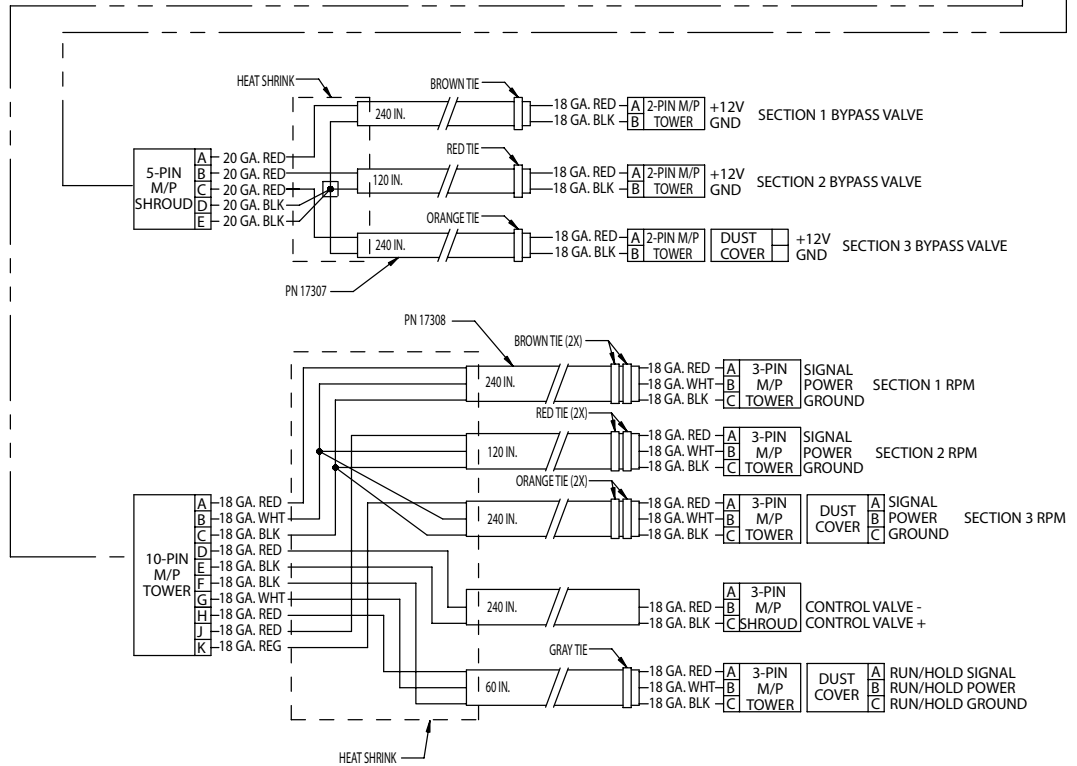



Five Drive Harness Kit System Diagram

OPTIONAL 7-PIN CABLES		
P/N 14146	5'	CABLE
P/N 14147	10'	CABLE
P/N 14103	15'	CABLE
P/N 14236	20'	CABLE
P/N 14237	25'	CABLE

OPTIONAL 10-PIN CABLES		
P/N 13220	5'	CABLE
P/N 13221	10'	CABLE
P/N 13222	15'	CABLE
P/N 13223	20'	CABLE
P/N 13224	25'	CABLE
P/N 14142	50'	CABLE

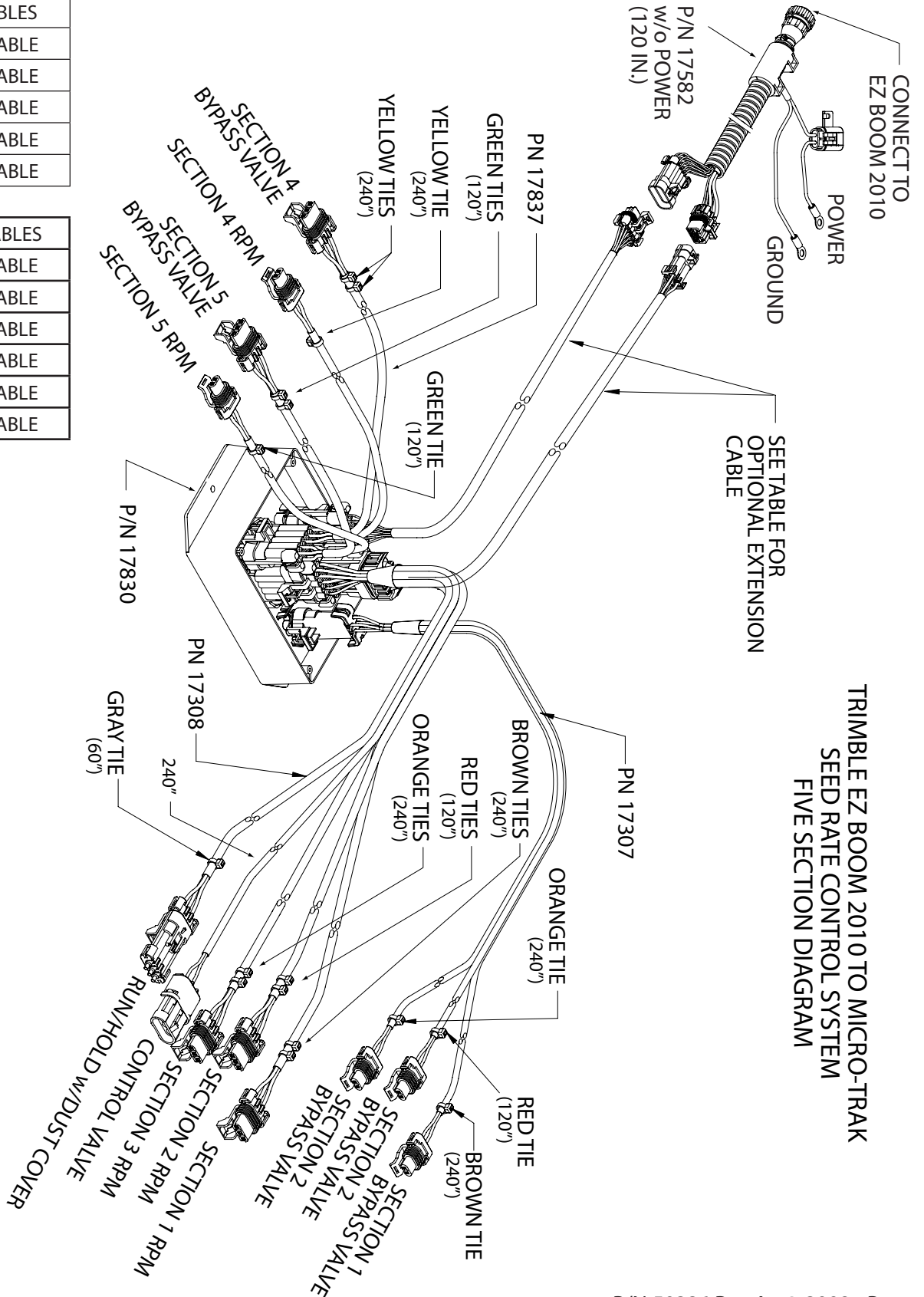

CONNECT TO
EZ BOOM 2010

POWER

GROUND

SEE TABLE FOR
OPTIONAL EXTENSION
CABLE

TRIMBLE EZ BOOM 2010 TO MICRO-TRAK
SEED RATE CONTROL SYSTEM
FIVE SECTION DIAGRAM



Five Drive Harness Kit Wiring Diagram

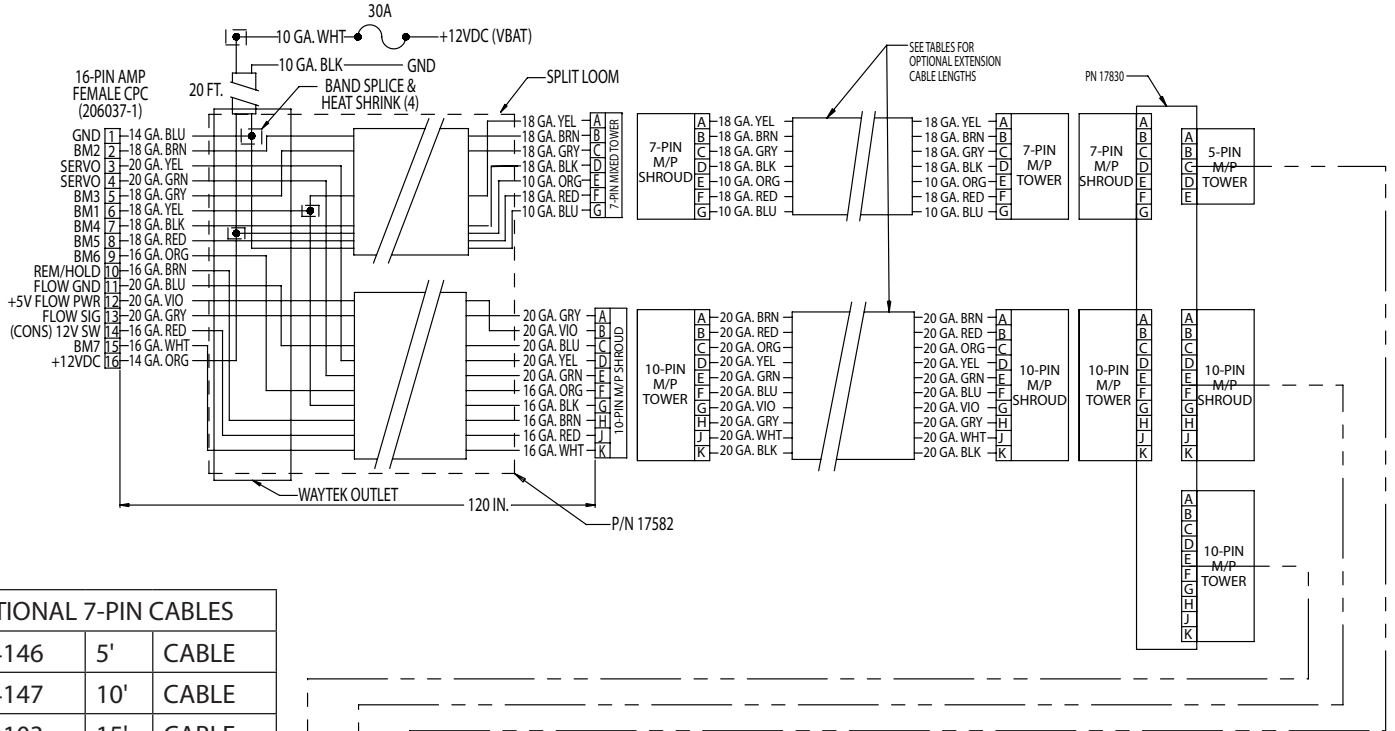

OPTIONAL 7-PIN CABLES		
P/N 14146	5'	CABLE
P/N 14147	10'	CABLE
P/N 14103	15'	CABLE
P/N 14236	20'	CABLE
P/N 14237	25'	CABLE

OPTIONAL 10-PIN CABLES		
P/N 13220	5'	CABLE
P/N 13221	10'	CABLE
P/N 13222	15'	CABLE
P/N 13223	20'	CABLE
P/N 13224	25'	CABLE
P/N 14142	50'	CABLE

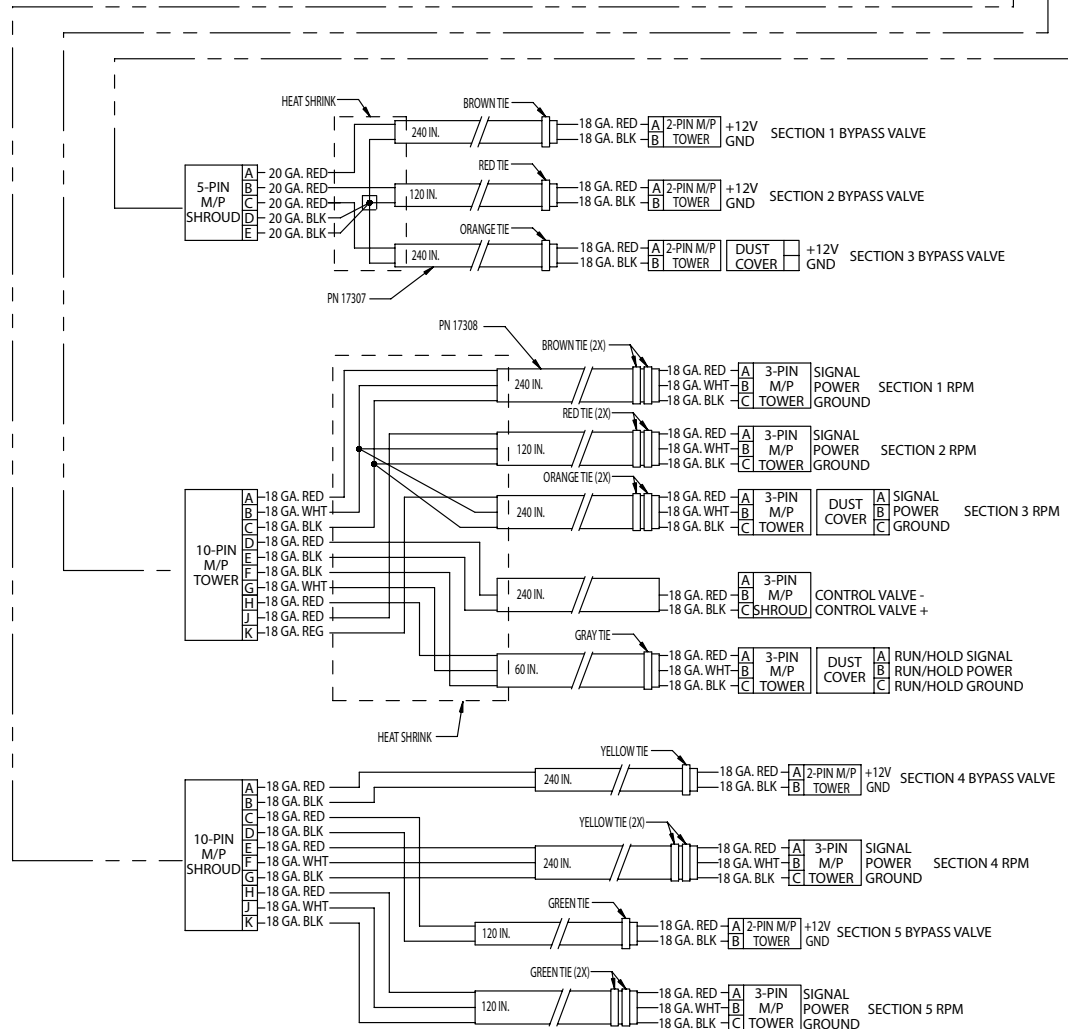



Single Drive Open Center Diagram

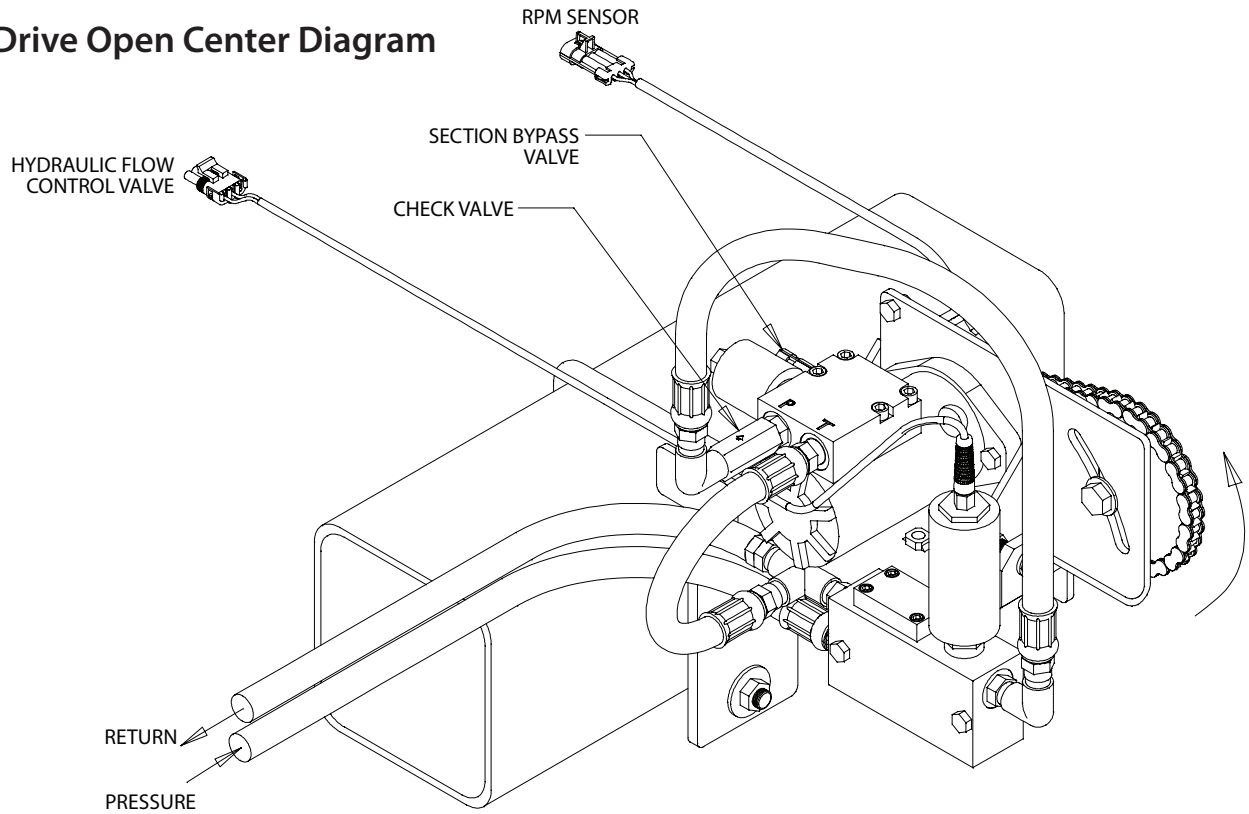

Single Drive Closed Center Diagram

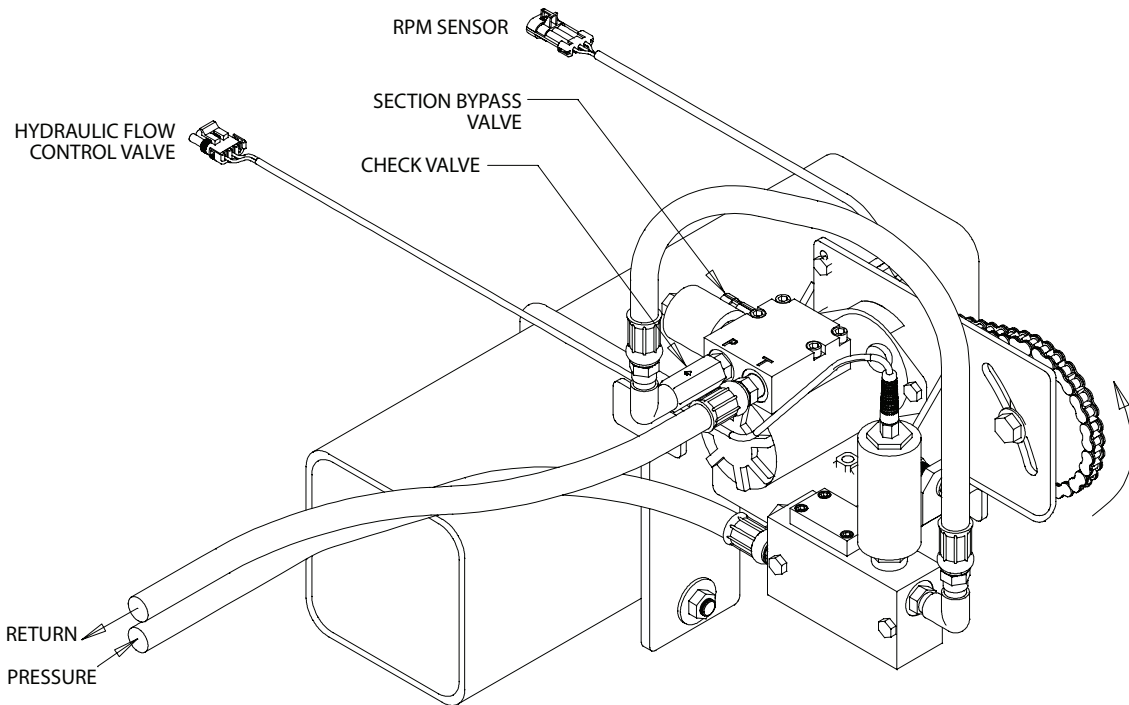



Dual Drive Open Center Diagram

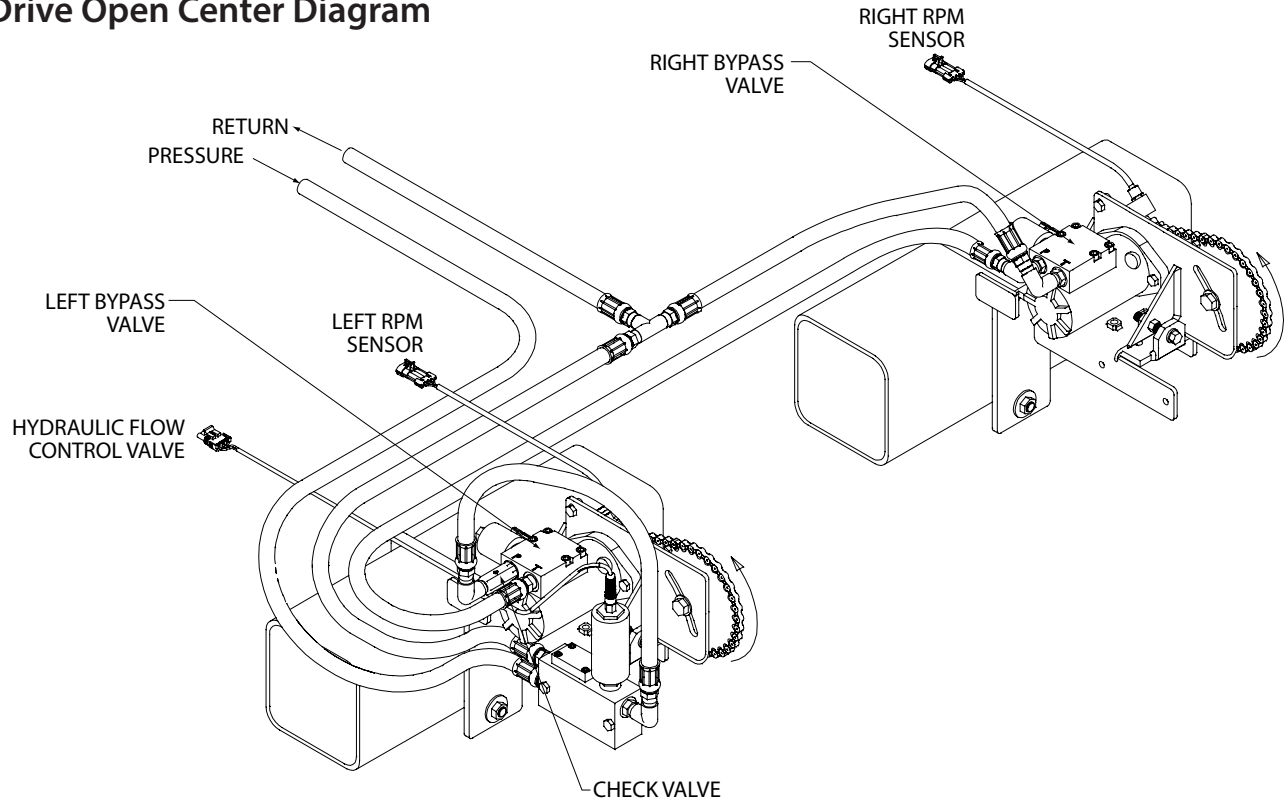

Dual Drive Closed Center Diagram

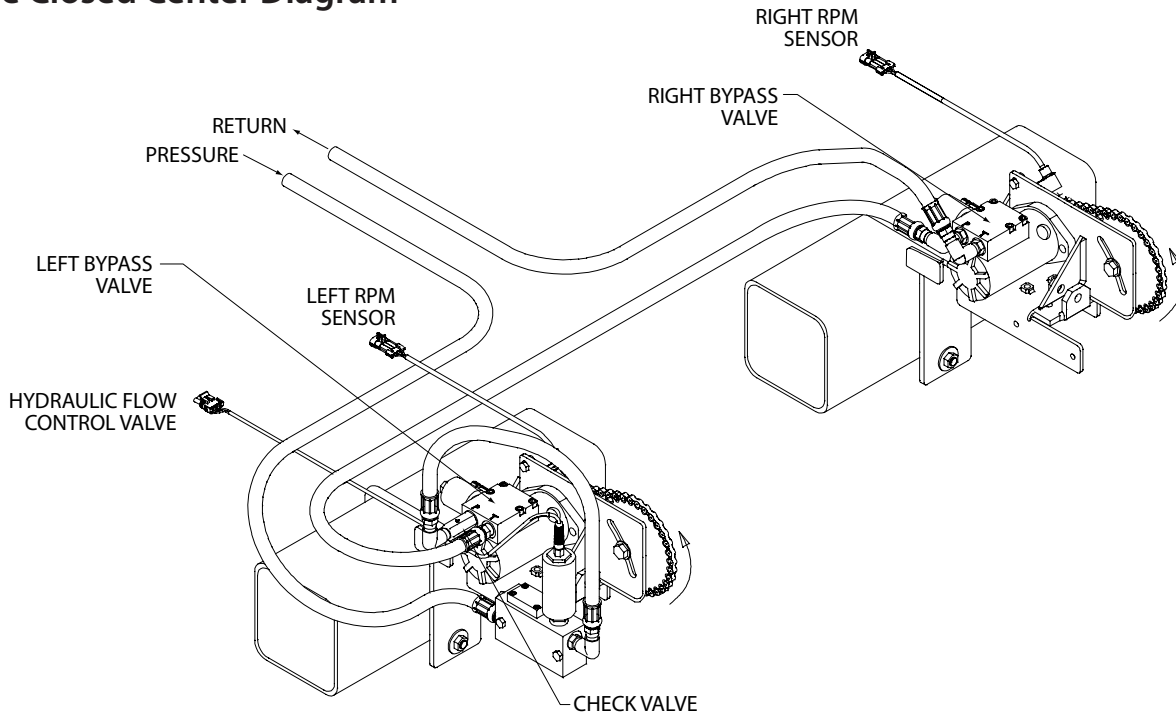

Multi Drive Open Center Diagram

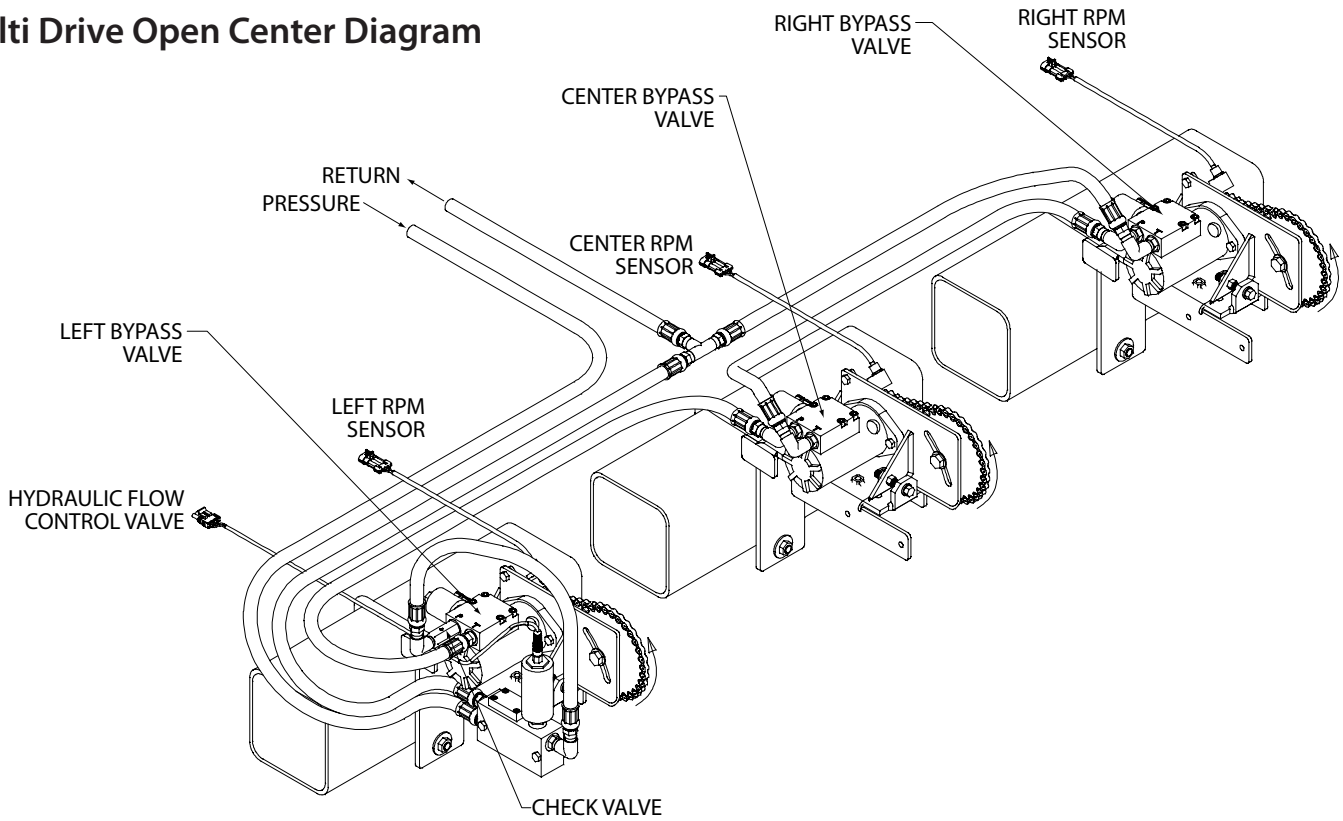

Multi Drive Closed Center Diagram

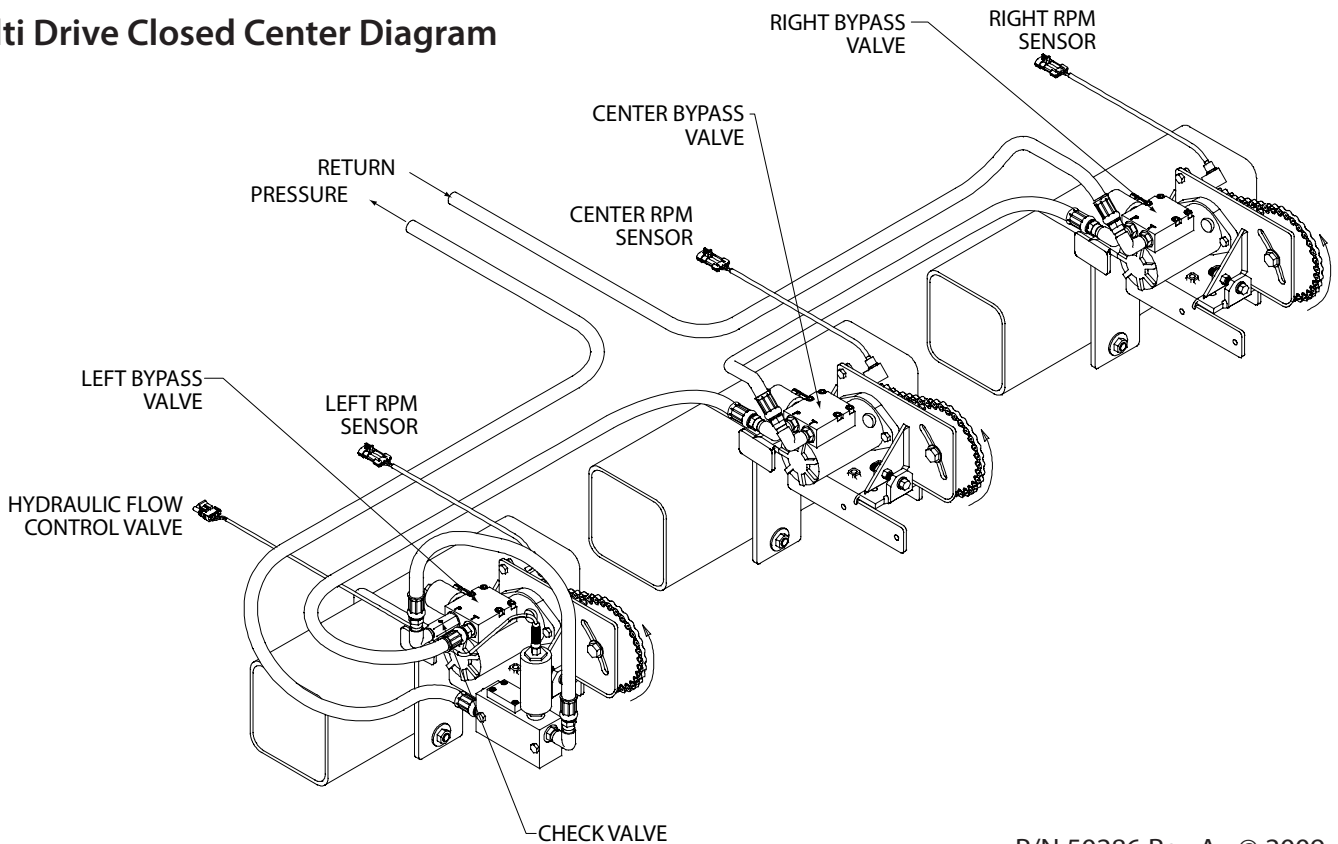

The value for Driven or Drive Sprocket refers to the number of teeth on the sprocket.

To calculate Ratio for a single stage chain drive, use the following equation:

(Driven Sprocket ÷ Drive Sprocket)

EXAMPLE: 32 ÷ 16 = 2.000

This means the Drive Sprocket will need to make 2 complete revolutions in order for the Driven Sprocket to make 1 revolution.

To calculate Ratio for a two stage chain drive, use the following equation:

(First Stage Driven Sprocket ÷ First Stage Drive Sprocket) x
(Second Stage Driven Sprocket ÷ Second Stage Drive Sprocket)

EXAMPLE: (32 ÷ 16) x (28 ÷ 16) = 3.500

In the above example, the First Stage Drive Sprocket will need to make 3.5 complete revolutions in order for the Second Stage Driven Sprocket to make 1 revolution.

To calculate Ratio for a three stage chain drive; use the following equation:

(First Stage Driven Sprocket ÷ First Stage Drive Sprocket) x
(Second Stage Driven Sprocket ÷ Second Stage Drive Sprocket) x
(Third Stage Driven Sprocket ÷ Third Stage Drive Sprocket)

EXAMPLE: (32 ÷ 16) x (28 ÷ 16) x (24 ÷ 18) = 4.666

In the above example, the First Stage Drive Sprocket will need to make 4.666 complete revolutions in order for the Third Stage Driven Sprocket to make 1 revolution.

Calculating your Flow Cal for a Planter Drive

1. Rows equals the number of rows the drive is running.
ROWS = _____
2. How many seeds are dispensed per revolution of your Seed Meter Disc?
SMD = _____
3. What is the Ratio of hydraulic motor revolutions to seed meter revolutions?
RATIO = _____ to 1
4. How many teeth are there on your Motor Sensor Sprocket?
MSS = _____

1000 Seeds ÷ **ROWS** = Seeds per Row

Seeds per Row ÷ **SMD** = Seed Meter Revolutions

Seed Meter Revolutions x **RATIO** = Motor Revolution

Motor Revolution x **MSS** = Pulses per 1000 Seeds (Flow Cal)

EXAMPLE:

ROWS = 12

SMD = 30

RATIO = 4.0

MSS = 16

1000 Seeds ÷ 12 = **83.333**

83.333 ÷ 30 = **2.777**

2.777 x Ratio = **11.111**

11.111 x 16 = **177.8**

177.8 = Flow Cal or Pulses per 1000 Seeds.

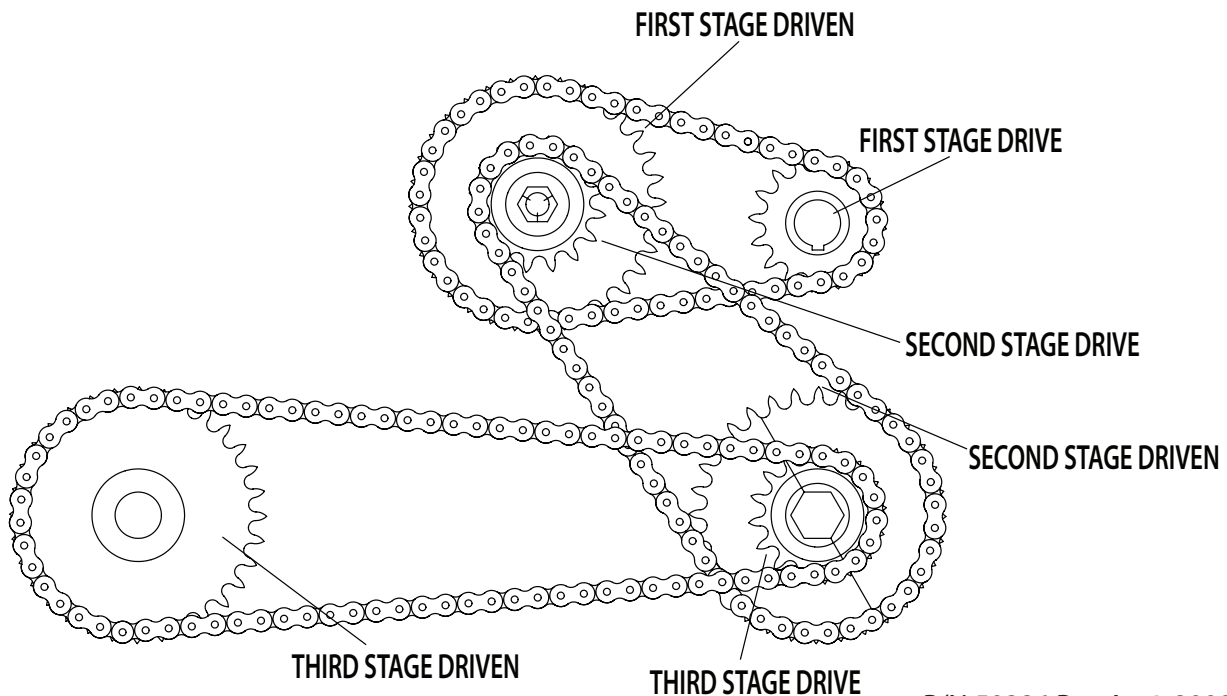



Instructions for Micro-Trak Seed Rate Control Systems Used with Trimble Controllers EZ Boom 2010 Installing the Planter Drive

1. Choose a location between row units for the tool bar mount bracket approximately five inches to the left of a hex shaft hanger bearing to the center of the tool bar mount bracket. Mount the bracket to the tool bar using the supplied 1/2" U-bolt making sure the bracket is square with the tool bar. It is important to mount the drive assembly as close as possible to a hex shaft hanger bearing.
 2. Mount the motor bracket assembly to the tool bar bracket using the four 3/8" by 1 1/4" flange bolts. Slide the motor bracket towards the tool bar as far as it will go and tighten the flange bolts.
- NOTE: Skip step 3 if you are installing a secondary drive assembly.**
3. Mount the hydraulic flow control valve to the motor bracket using the two 5/16" by 2 3/4" bolts and 5/16" flange nuts. Be sure the output of the control valve is pointed away from the tool bar.
 4. Install the split sprocket on the hex shaft. Align the hex shaft sprocket with the outside idler sprocket and tighten.
 5. Cut a piece of chain to 23 1/2" and install on inside motor sprocket and idler sprocket using one of the supplied connector links. Tighten chain by loosening idler sprocket and sliding down and retighten.
 6. The length of chain required between the outside idler sprocket and hex shaft sprocket varies by planter manufacturer and model, so you will need to measure to determine the length. Cut to length and install using the supplied connector link.

7. Loosen the four 3/8" flange bolts installed in step 2.
8. Locate the full threaded 1/2" by 3" bolt, 1/2" jam nut and 1/2" flat washer. Install the flat washer on the bolt and insert through the tab on the back of the tool bar bracket, thread the jam nut on and then thread bolt into the motor bracket. Use this bolt to adjust the chain between the idler and the hex shaft and tighten the four 3/8" flange bolts.
9. Locate the four SAE #8 male x JIC #8 male straight adapters and two 90 degree swivel nut elbows and install in both the "P" pressure and "T" tank ports on the valve mounted on top of the hydraulic motor. The other two adapters go in the input and output ports on the control valve. Install the elbows on the "P" port on valve and output port on control valve.
10. Locate the 1/2" hose assembly and install between the "P" port and output port.
11. Locate the SAE #8 male plug and install in the bypass port of the control valve unless the drive assembly is connected to an open center hydraulic system.
12. Install the sensor bracket to the motor bracket near the motor sprocket using one of two 1/4" by 3/4" bolts and flange nuts. 13. Install gear tooth sensor to sensor bracket using the remaining 1/4" by 3/4" bolt and flange nut and adjust so that the sensor is pointed directly at the center of the motor shaft and 1/16" away from the tip of the sprocket teeth.

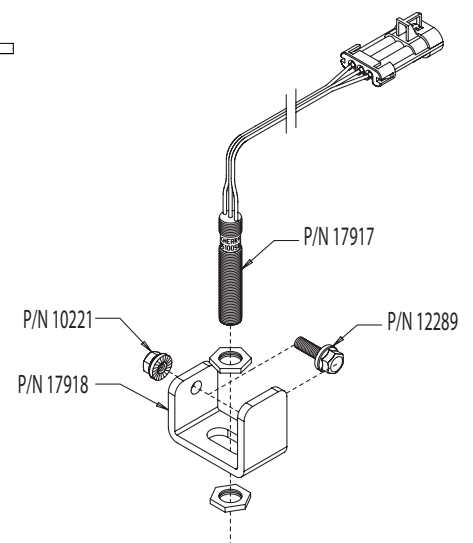
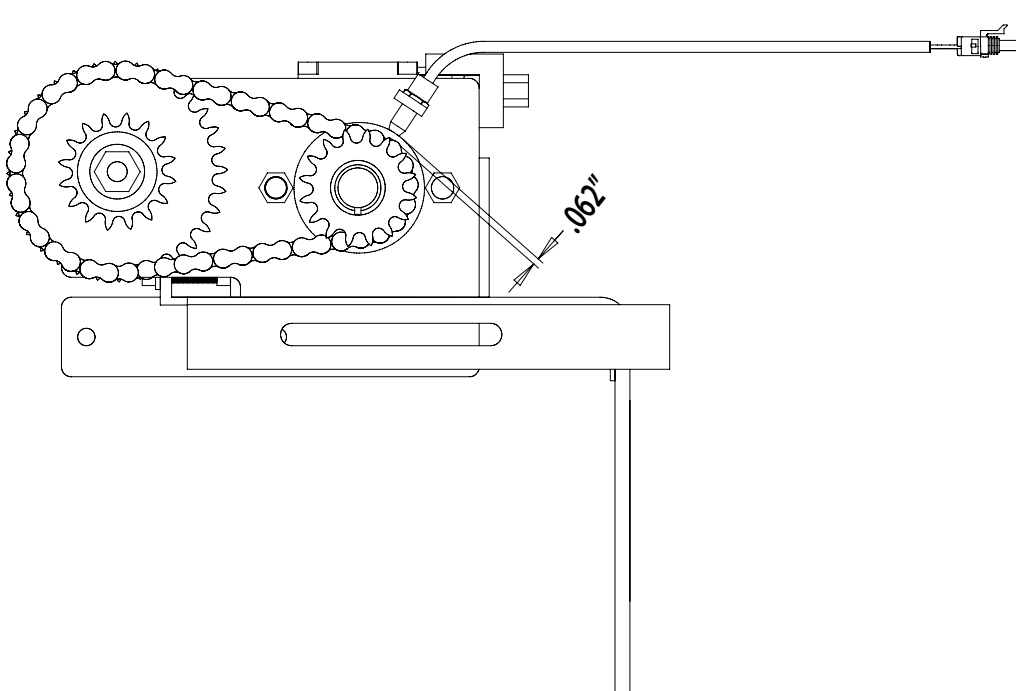



Instructions for Micro-Trak Seed Rate Control Systems Used with Trimble Controllers EZ Boom 2010 Installing the Planter Drive (cont)

Calculate your Hydraulic Oil Needs

1. What is your Maximum Planting Speed in miles per hour?
MPS = _____
2. What is the closest Desired Seed Spacing in inches?
DSS = _____
3. How many seeds are dispensed per revolution of your Seed Meter Disc?
SMD = _____
4. What is the Ratio of hydraulic motor revolutions to seed meter revolutions?
Ratio = _____ to 1
5. What is the Displacement in Cubic Inches of the hydraulic motor on your planter drive assembly?
CID = _____

EXAMPLE:

MPS = 5
DSS = 6.5
SMD = 30
Ratio = 5.333
CID = 4.9

- $(\text{MPS} \times 5280) \times 12 = \text{Inches traveled per hour}$
 $(5 \times 5280) \times 12 = 316800 \text{ inches traveled per hour}$
- $\text{Inches traveled per hour} \div \text{DSS} = \text{Seeds per hour}$
 $316800 \div 6.5 = 48738.46 \text{ seeds per hour}$
- $\text{Seeds per hour} \div \text{SMD} = \text{Seed meter revolutions per hour}$
 $48738.46 \div 30 = 1624.6 \text{ seed meter revolutions per hour}$
- $\text{Seed meter revolutions per hour} \div 60 = \text{Seed meter revolutions per minute}$
 $1624.6 \div 60 = 27 \text{ seed meter revolutions per minute}$
- $\text{Seed meter revolutions per minute} \times \text{Ratio} = \text{Hydraulic motor revolutions per minute}$
 $27 \times 5.333 = 144.4 \text{ hydraulic motor revolutions per minute}$
- **NOTE: the minimum recommended motor RPM is 30.**
- $\text{Hydraulic motor revolutions per minute} \times \text{CID} = \text{Cubic inches of hydraulic oil per minute}$
 $144.4 \times 4.9 = 707.6 \text{ cubic inches of hydraulic oil per minute}$
- $\text{Cubic inches of hydraulic oil per minute} \div 231 = \text{Gallons of hydraulic oil per minute}$
 $707.6 \div 231 = 3 \text{ gallons of hydraulic oil per minute}$

Connecting the Planter Drive Assembly to the Hydraulic System

Determine your hydraulic system type before proceeding.

Is it an:

- Open Center System?
- Closed Center System?
- Pressure Compensating
- Closed Center Load Sensing?

From a hose connectivity standpoint, there are just **TWO VARIATIONS** in plumbing and are referred to here as either Open Center or Closed Center configurations.

NOTE: See the illustrations on the following pages for hydraulic hose plumbing detail for opened and closed center hydraulic systems as well as single, dual and multi-drive configurations.

The hose end fitting required to mate with the supplied adapters is a #8 JIC 37 degree female.

The recommended hydraulic hose size is 1/2" for both the pressure and return hoses.

Be sure to route hoses away from pinch points and leave enough excess length to accommodate folding and unfolding.

Whether you have an open or closed hydraulic system be sure to turn the oil flow down to about 20% more than calculated because the excess oil flow means excess heat.

See how to calculate your hydraulic oil needs at the top of this page.