

TABLE OF CONTENTS



Safety Notices	1
System Overview	3
Virtual Terminal (VT).....	3
Master Switch	4
Working Set Master (WSMT) Module (Planter Drill Control).....	4
Working Set Member (WSMB) Module (optional).....	5
Implement Lift Switch (optional).....	5
CAN Terminators	5
System Requirements	7
Performance Features	7
Compatibility	8
Installation	9
Virtual Terminal.....	9
Master Switch	9
Working Set Master (WSMT) Module	10
Working Set Member (WSMB) Module.....	12
Cab Harness Connections.....	15
Sensor Installation	21
Seed Sensors.....	21
Hopper Level Sensors.....	23
RPM/Fan Sensors.....	23
Air Pressure Sensors	23
System Modes.....	25
User Level Access	25
Operate Mode	25
Available Buttons in Operate Mode	26
Setup/Configuration Mode	28
Available Buttons in Setup Mode	28
Planter Fill Disk	28
Row Monitor Setup.....	28
Control Setup	28
Speed Set	29
Diagnostics.....	29
Alarm Log.....	29
System Accumulators	29
Module Configuration	29
Screen Configuration	29
Planter Output Module (POM) Configuration (optional)	29
Configuration.....	29
User Levels.....	31
User Level 1 Operator (Basic View).....	31
Change Operator Level to OEM/Dealer Level	32

TABLE OF CONTENTS



System Configuration	35
Control Setup Overview.....	35
Material/Channel Setup Steps.....	35
Control Channel and Material Selection	37
Material Assignment (Matrl 1-16)	37
Material Setup	38
Create a Material Name	38
Type.....	39
Units	39
Preset Method Enabled.....	39
Preset Method Disabled	40
Material Setup Constants - Planter Control	41
Target Rate.....	41
Max Rate	41
Min Rate	41
Inc/Dec %	41
Seeds Per Rev	42
Disc High Limit.....	42
Disc Low Limit	42
Prod Level Alarm	42
High and Low Population Alarm	42
Row Width	43
On/Off Pattern	43
Row Fail Rate.....	43
Material Setup Constants-Gran Seed and Gran Fertilizer Control	44
Target Rate.....	44
Max Rate	44
Min Rate	44
Inc/Dec %	44
Density.....	45
Spreader Constant	45
High Shaft RPM.....	45
Prod Level Alarm	45
Seeds Per Pound	46
High and Low Population Alarm	46
Row Width	46
On/Off Pattern	47
Row Fail Rate.....	47
Material Setup Constants-Liquid Flow	48
Target Rate.....	48
Max Rate	48
Min Rate	48
Inc/Dec %	48
Low Flow Limit.....	49
High Flow Limit.....	49
Product Level Alarm	49
Material Setup - Monitor Only.....	50
Type.....	50
Target Population	50
High and Low Population Alarms	50
Row Width	50
On/Off Pattern	51
Row Fail Rate.....	51
Material Setup Constants - RPM Control	52
Target Rate.....	52
Max Rate	52
Min Rate	52
Inc/Dec %	52

TABLE OF CONTENTS



Control Channel Setup	53
Planter Control Setup.....	54
Type	54
Material Name.....	54
Control Mode.....	54
Drive Type.....	55
Drive Frequency.....	55
Sensor Constant	55
Gear Ratio.....	55
Number (#) of Seed Rows.....	55
Channel Width.....	55
Precharge Time.....	55
Flush Enable	57
Valve Calibration - Planter Control.....	58
Fill Disk	59
Continuous Test.....	61
Test Ground Speed.....	61
Row	61
Test Target Pop	61
Test Seed Count	62
5 Rev Test.....	62
Test Ground Speed.....	63
Row	63
Test Target Pop	63
Test Seed Count	63
Remote Test Switch.....	63
Granular Seed and Granular Fert Setup.....	64
Valve Calibration - Gran Seed and Gran Fert.....	67
Fill Disk	68
Fill Disk for a Control Channel	68
Limit Output.....	70
Spreader Calibration- Gran Seed and Gran Fertilizer.....	71
Density	71
Spreader Constant	71
Target Meter RPM.....	72
Number (#) Meter Revs.....	72
Pulse Count.....	72
New Spreader Constant.....	72
Amount Dispensed.....	72
Shaft Turn	72
Liquid Flow Setup	73
Manual w/o Feedback.....	73
Valve Calibration - Liquid.....	76
Liquid Flow Calibration.....	78
RPM Control Setup.....	80
Type	80
Material Name.....	80
Manual w/o Feedback.....	80
Drive Type.....	81
Drive Frequency.....	81
Input Filter	81
Sensor Constant	81
Master Switch Off.....	81
Ramp Up/Down.....	81
Disable Control On Control Failure Alarm.....	82
Valve Calibration - RPM Control.....	83

TABLE OF CONTENTS



Module Configuration	85
Serial Number and Module Type	85
Module Address	86
Auto Sort	87
Auto Configuration	87
Auto Sort and Auto Config Examples	88
Row Assignment	92
Row Status/Row Width Setup	93
Row Width	93
Auto Update Width	93
Implement Width	94
On/Off Pattern	94
Blockage Pattern	95
Hopper Assignment	96
Hopper Set	97
Logic Level	97
Alarm Delay	98
Channel	98
Accessory Assignment	98
# Of Pressure/RPM Sensors	99
RPM Setup	99
High Alarm	99
Low Alarm	99
High Alarm Delay	100
Low Alarm Delay	100
RPM Constant	100
RPM Filter	100
Disable Control on Low Alarm	100
Pressure Sensor Setup	101
High Alarm	101
Low Alarm	101
High Alarm Delay	101
Low Alarm Delay	101
Pressure Filter	102
Row Monitor Setup	103
Material Name	103
High Alarm Delay	103
Low Alarm Delay	104
Population Adjust	104
Population Filter	104
Row Fail Rate	104
Ground Speed Setup	105
Source	105
GSPD Constant	106
Shut Off Speed	106
Minimum Override	106
Master Switch Timeout	107
Ground Fail Alarm Delay	107
Precharge Ground Speed	107
Flush Enable Speed	107
Implement Lift	107
Ground Speed Calibration	108
10" VT Aux Input/Function Assignment	109
5" VT Aux Input/Function Assignment	110

TABLE OF CONTENTS



Work Screen Configuration.....	113
Bargraph Setup.....	113
Return System Active Delay.....	114
Summary Screen.....	115
Data Items.....	117
Clearing Accumulators.....	117
Control Actual Channels 1-4.....	117
Control Target Channels 1-4.....	117
Control Rate Channels 1-4.....	118
Control Scan.....	118
Pop Row Scan.....	118
Pop Min Max Row Scan.....	118
Pop Min Row.....	119
Pop Max Row.....	119
Pop Avg.....	119
Spacing Row Scan.....	119
Spacing Min Max Row Scan.....	119
Spacing Min Row.....	120
Spacing Max Row.....	120
Spacing Avg.....	120
Seed/Distance Row Scan.....	120
Seed/Distance Min Max Row Scan.....	120
Seed/Distance Min Row.....	121
Seed/Distance Max Row.....	121
Seed/Distance Average.....	121
Singulation Average.....	121
Singulation Row Scan.....	121
Singulation Min Max Scan.....	121
Ground Speed.....	122
Total Area.....	122
Field 1 Area.....	122
Field 2 Area.....	122
Channels 1 - 4 Area.....	123
Area Scan.....	123
Control Feedback Scan.....	123
Area Per Hour.....	123
System Active Time.....	123
Seed Count Accum Row.....	124
Distance Accumulator.....	124
Channels 1 - 4 Material Accum.....	124
Accessory Input Scan.....	124
Pressure Scan.....	124
RPM Scan.....	125
Channel 1-4 Product Level.....	125
Hopper Level Status Scan.....	125
Boom Status.....	125
Guidance Status.....	125
Pre-Operating Preparation.....	127
Fill Disk for All Control Channels.....	127

TABLE OF CONTENTS



System Operation	129
Start	129
Stop	129
Operate Screen Symbols	130
Target Rate.....	130
Increase/Decrease % Rate.....	130
Target Preset Rate	130
Implement Lift Switch	130
Task Controller	130
Row Indicators.....	130
Autopilot Steering Navigation	131
Accumulators.....	131
Population Row Scan	131
Singulation Average Population	131
Material Name	131
Population Max Row.....	132
Population Min Row.....	132
Precharge Feature.....	132
Flush Enable.....	134
System Information and Diagnostics	135
System Accumulators Screen	135
Powered On Time.....	135
System Active Time.....	135
System Active Area	135
Distance.....	136
Diagnostics	136
CH Setpoint	136
CH Target	136
CH Actual Rate.....	137
CH RPM/GPM	137
CH PWM.....	137
CH Pulse Count.....	137
CH Freq Filt	137
Freq Rel GSPD.....	137
Freq Dig GSPD.....	137
Freq Press 1	137
IO Hopper 1	137
IO Imp Lift	138
Application ID	138
Sol Pwr Volt	138
ECU Pwr Volt.....	138
Snsr Pwr Volt.....	138
Gnd Volt.....	138
Diagnostics Manual Valve Position	138
Manual Open of Channel.....	138
Seed Count Screen	139
Information Screen	140
Resetting Novram Values.....	141
Acknowledging Alarm Conditions	141
Alarm Log	142
Alarm Detail	143
Alarm Reset.....	143

TABLE OF CONTENTS



Task Controller	145
Implement Offset.....	145
Calculating Implement Offset	145
Channel Linking	146
Material Application Rates	146
Import/Export Data.....	147
Troubleshooting & Alarms	151
Appendix	161
Warranty	163

TABLE OF CONTENTS





SAFETY NOTICES

Safety notices are one of the primary ways to call attention to potential hazards.



This Safety Alert Symbol identifies important safety messages in this manual. When you see this symbol, carefully read the message that follows. Be alert to the possibility of personal injury or death.

⚠ WARNING

Use of the word **WARNING** indicates a potentially hazardous situation which, if not avoided, could result in death or serious injury.

⚠ CAUTION

Use of the word **CAUTION** with the Safety Alert Symbol indicates a potentially hazardous situation which, if not avoided, may result in minor or moderate injury.

CAUTION

Use of the word **CAUTION** without the safety alert symbol indicates a potentially hazardous situation which, if not avoided, may result in equipment damage.

OPERATOR'S MANUAL





SYSTEM OVERVIEW

The DICKEY-john IntelliAg Planter Drill Control system controls planting, liquid, and granular applications. The IntelliAg is designed to ISO 11783 CAN communication standards providing the capability of communicating with other manufacturer's ISO 11783-compatible equipment.

The IntelliAg consists of:

- 5" Virtual Terminal or a 10" Virtual Terminal
- Master Switch
- Working Set Master Module
- Up to 11 Working Set Member Modules (monitors up to a total of 214 rows of seed input) (optional)
- Implement Lift (optional)
- CAN Terminators
- TECU (10" VT only)
- Video Surveillance (10" VT only)

All of the devices communicate using the ISO 11783 CAN communications standard. System components are described in the following section.

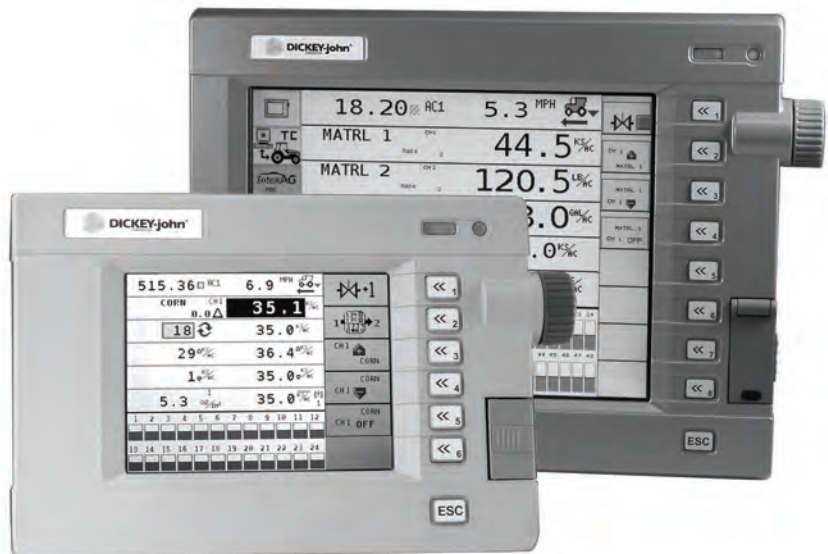
NOTE: Examples shown throughout this manual depict display screens of the 10" Virtual Terminal display.

VIRTUAL TERMINAL (VT)

A 5" or 10" Virtual Terminal provides user interface with the IntelliAg system used for output and input of data. Reference the VT operator's manual for setup and configuration instructions.

Figure 1

5" or 10" Virtual Terminal

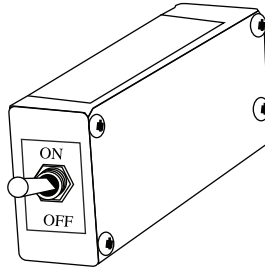




MASTER SWITCH

Figure 2

Master Switch

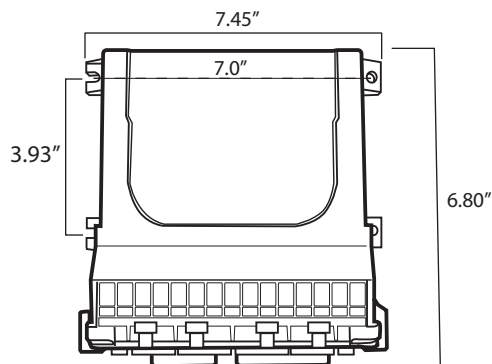


The Master Switch starts and stops product application through a single switch. The two switch positions are ON and OFF. The normal operating position for field application is ON. In this position, ground speed controls the application rate. When ground speed is reduced to zero, all application ceases. The OFF position inhibits all product flow. When set to the OFF position, the system shuts off for safety and travel purposes. Setup and configuration of the system is accomplished when the Master Switch is in the OFF position. The Master Switch is also housed inside the cab of the tractor.

WORKING SET MASTER (WSMT) MODULE PDC (PLANTER DRILL CONTROL)

Figure 3

Working Set Master Module



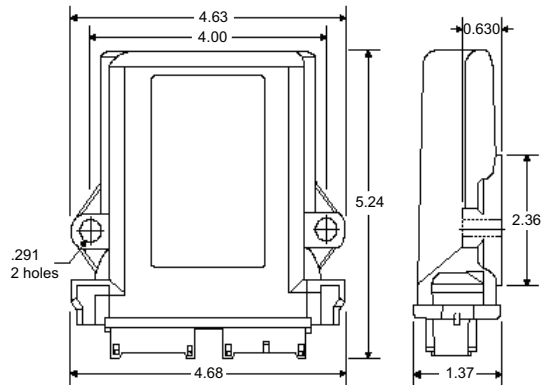
The Working Set Master (WSMT) module houses the system's primary interface device. All system parameters, constants, and memory are stored in the WSMT. The WSMT has four channels for planter, granular seeding, granular fertilizer, liquid flow or RPM control. In addition, the WSMT can accept inputs from 1 hopper level, 1 RPM or pressure sensor, 1 lift switch, 1 ground speed sensor and up to 16 seed sensors. The WSMT module uses a 48-pin connector with a jackscrew to secure the connector to the module. The WSMT is typically mounted on the implement.



WORKING SET MEMBER (WSMB) MODULE (OPTIONAL)

Figure 4

Working Set Member Module



Each Working Set Member (WSMB) module is an auxiliary to the Working Set Master (WSMT). Each WSMB can accept up to 18 rows of seed sensors. The WSMB passes information directly to the WSMT. Up to 11 WSMB's can be installed to monitor up to 214 rows. The flexible design of the WSMB allows for installation virtually anywhere on the implement.

IMPLEMENT LIFT SWITCH (OPTIONAL)

The Implement Lift Switch detects the position of the implement. When using an Implement Lift Switch, the Master Switch can be left in the ON position during operation, and the system will be turned OFF and ON as the implement is raised and lowered. The Master Switch should be turned OFF when in transport, when stationary, or when the operator has left the cab.

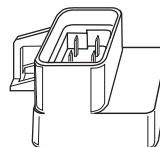
CAN TERMINATORS

CAN Terminators are necessary for proper communication between each component of the system.

- One terminator is located on the cab harness, approximately 30 inches from the Virtual Terminal connector.
- One terminator plugs into the implement harness of the last module connected to the CAN bus.

Figure 5

Can Terminator



OPERATOR'S MANUAL





SYSTEM REQUIREMENTS

The minimum requirements to operate the IntelliAg Planter/Drill Control system consist of:

- Virtual Terminal
- Master Switch
- Working Set Master
- Two CAN terminators
- TECU (10" VT only)

Optional and not required for system operation:

- Working Set Member(s)
- Clutch/Switch Folding Module and Planter Output Module
- Remote Test Switch (required for Continuous Test and 5 Rev Test)

PERFORMANCE FEATURES

- Two user access levels for viewing and setting constants
 - User Level 1 (End User)
 - User Level 2 (OEM/Dealer)
- Monitoring of up to 214 rows, ground speed, one hopper level, one shaft sensor, one lift switch
- Easy and flexible configuration
- View of functions including:
 - control actual rates
 - control target rates
 - control rate
 - control scan
 - population row scan
 - population min/max scan
 - population min row
 - population max row
 - population average
 - spacing row scan
 - spacing min/max scan
 - spacing min row
 - spacing max row
 - spacing average
 - seeds per distance row scan
 - seeds per distance min/max row scan
 - seeds per distance min row
 - seeds per distance max row
 - seeds per distance average
 - singulation average
 - singulation row scan
 - singulation min/max scan
 - ground speed
 - total area
 - field area - 1 and 2
 - channel areas 1-4



Viewable functions continued-

- area scan
- pressure scan
- RPM scan
- control feedback scan
- area per hour
- system active time
- seed count accumulator
- distance accumulator
- control channel material accumulation 1-4
- channel product level 1-4
- hopper level status scan
- boom status
- guidance status

COMPATIBILITY

- Compatible with DICKEY-john sensors



INSTALLATION

VIRTUAL TERMINAL

Reference the Virtual Terminal (VT) operator's manual for installing the VT to the tractor cab. Once the Virtual Terminal has been mounted, connect the Tractor (Cab) Harness as illustrated in [Figure 13](#) or [Figure 14](#).

Figure 6

5" and 10" Virtual Terminals



MASTER SWITCH

1. Install the master switch within easy reach of the operator.
2. Once mounted, connect the master switch to the tractor (cab) harness as illustrated in [\(Figure 13\)](#) or [\(Figure 14\)](#).

Figure 7

Master Switch

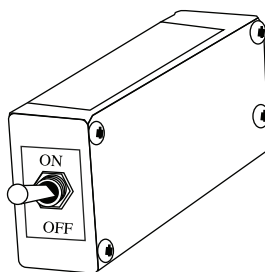
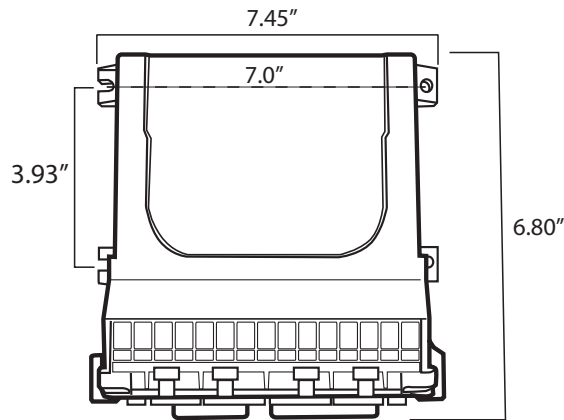




Figure 8

Working Set Master Module



WORKING SET MASTER (WSMT) MODULE

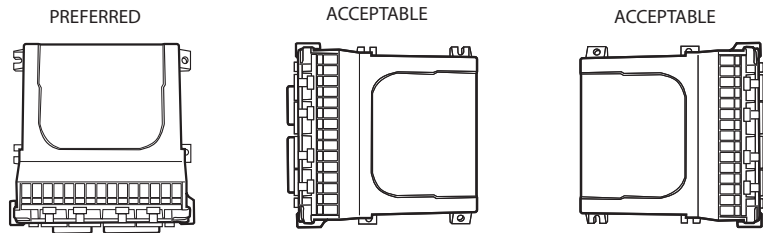
1. Select an area on the implement to mount the WSMT that allows for easy hookup and access. Use the enclosure as a template to mark the location of the mounting holes. Drill four 9/32 inch diameter holes where marked.

IMPORTANT: Do not use the enclosure as a guide when drilling. Do not overtighten nuts as this may damage the mounting tabs of the enclosure.

The WSMT may be mounted in any of the following orientations:

Figure 9

Acceptable Orientation



CAUTION

Do not install the module in any orientation other than shown in (Figure 9). The connection wires must not be mounted upward, as moisture can collect inside the unit and damage the circuits. Ensure that module connectors do not face upward when implement is in a folded position as well.

2. Mount with the label side of module facing out. Do not mount with the connector facing up (see Caution).



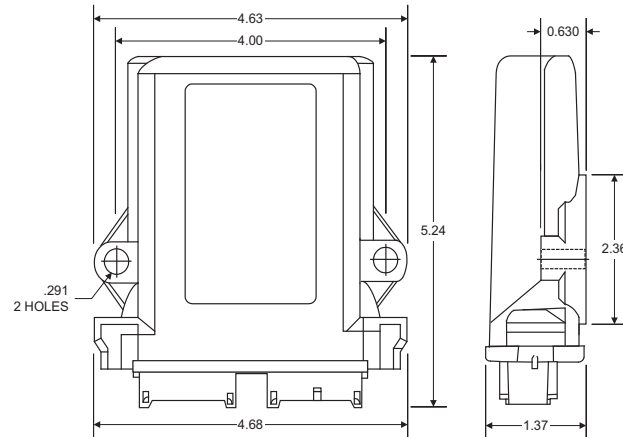
3. Connect any additional adapter harnesses to the module harness. The WSMT Module harness can accept the following adapter harnesses:
 - **Actuator Harness:** This harness allows for up to 4 output control channels, 4 control channel feedbacks, a hopper level sensor input, a shaft sensor input, a ground speed input, and an implement switch input. In addition, a pair of 6-pin connectors are available for Servo connection which use FB1/FB2 respectively. Install sensors, valves, etc. per the instructions included with the items. Install the PWM valve assembly and feedback sensor for each control loop and connect the devices to their respective inputs on the harness, making certain to match PWM 1/Servo 1 with FB 1, PWM 2/Servo 2 with FB 2, etc. Secure any unused and excess cable lengths where necessary. Refer to (Figure 15) for additional information.
 - **Seed Sensor Harness:** This harness accommodates any standard Dj Seed Sensor harness (PM style) or SE style harness depending on the WSMT harness. A wide variety of harnesses are available to accommodate various numbers of sensor inputs. Install all seed sensors per the instructions included with the individual sensors. Secure any unused or excess cable lengths as necessary.



WORKING SET MEMBER (WSMB) MODULE

Figure 10

Working Set Member Module



IMPORTANT: For applications using multiple modules, it is recommended that the WSMB's are mounted on the implement by increasing serial number order from left to right. This step will minimize setup time at the Module Configuration screen pressing the Auto Sort button will group same module types together and in the order the modules are mounted on the implement.

After Auto Sort is performed, modules will appear on the Module Configuration screen in groups by serial number order and module type.

1. Select an area on the implement to mount the member that allows for easy hookup and access. Extensions may be used to reach members installed on remote areas of the implement.
2. The module can be mounted in the same orientations as the Working Set Master (WSMT) as illustrated in (Figure 9).

CAUTION

Do not install the module in any orientation other than illustrated in (Figure 9). The connection wires must not be mounted upward as moisture can collect inside the unit and damage the circuits. Ensure that module connectors do not face upward when implement is in a folded position as well.

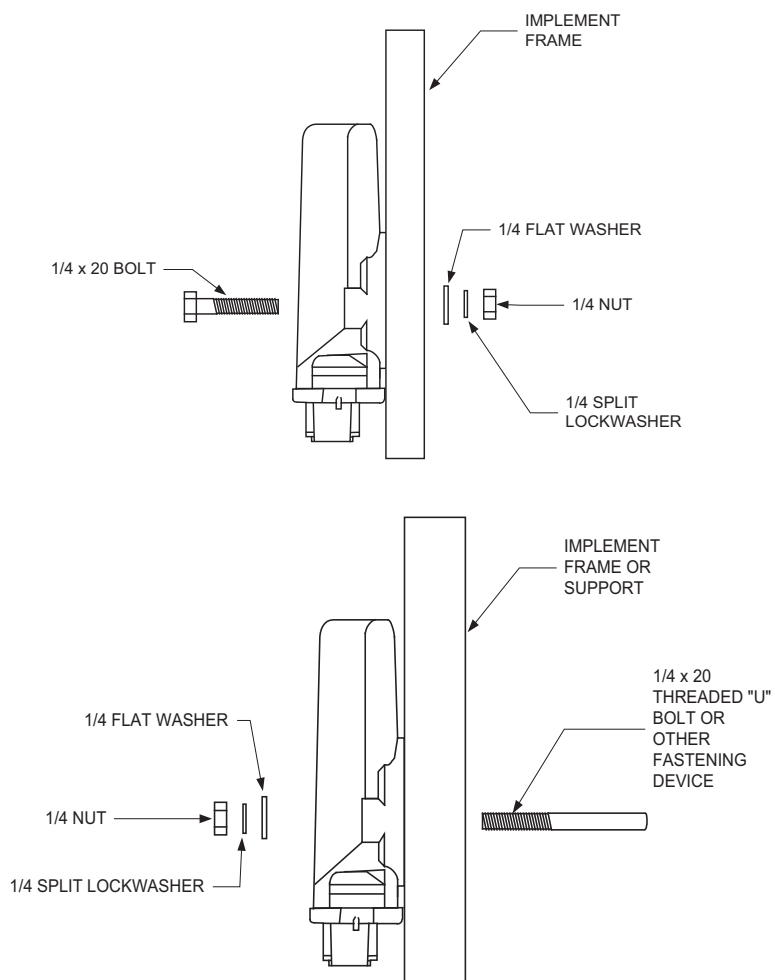
3. Mount with the label side of the module facing out.
4. To bolt the member to a frame:
 - Use the enclosure as a template to mark the location of the mounting holes.
 - Drill two 9/32 inch diameter holes where marked.
 - Attach to frame using 1/4 x 20 bolts or other fastening devices as illustrated in (Figure 11).



CAUTION

Do not use the enclosure as a guide when drilling. Do not overtighten nuts as this may damage the mounting tabs on the enclosure.

Figure 11
Working Set Member Installation (Bolted)

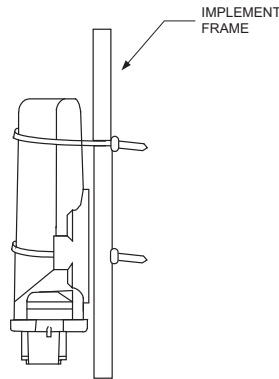




5. To tie-strap the member to a frame:
 - Use one long tie-strap to loop around the member body and through both mounting holes as illustrated in (Figure 12).
 - If necessary, drill mounting holes following the procedure described above.
 - Securely tighten tie-strap.
 - Install a second tie-strap toward the label end of the enclosure for additional support.

Figure 12

Working Set Member Installation (Tie-Strap)



6. Connect a WSMB harness to the WSMB module and connect the WSMB harness to the Power/CAN backbone, refer to (Figure 16).
7. Connect each module harness to its module, inserting both connectors until the connector locking tabs engage.
8. Lay out the planter harness along the frame of the implement to each of the seed sensors. For seed sensors, extensions will most likely not be necessary.
9. Route sensor wires in locations where they will not be damaged by chains, drive shafts, sprockets, etc.
10. Secure the harness to the toolbar with a minimum of 3" straight wire exiting the module before bending and attaching with tie-straps.
11. Coil and secure any unused sensor connections.
12. The WSMB Module harness can accept a standard DICKEY-john PM style planter harness (single round 37-pin connector) or an SE style planter harness (1 gray 12-pin, 1 black 12-pin rectangular connector) depending on the WSMB harness used. Harnesses are available for a number of row configurations.
 - Route the planter harness on the implement, securing as necessary.
 - Install seed sensors per the instructions included with the sensors. Refer to the implement harness diagram for additional information (Figure 13) or (Figure 14).

NOTE: The last module harness in the system must have a CAN Terminator installed for proper system operation. Refer to Implement Harness (Figure 13) or (Figure 14) for additional information.

IMPORTANT: Be sure the locking tabs engage when inserting the connectors. The connection is sealed only when the locking tabs have fully engaged.

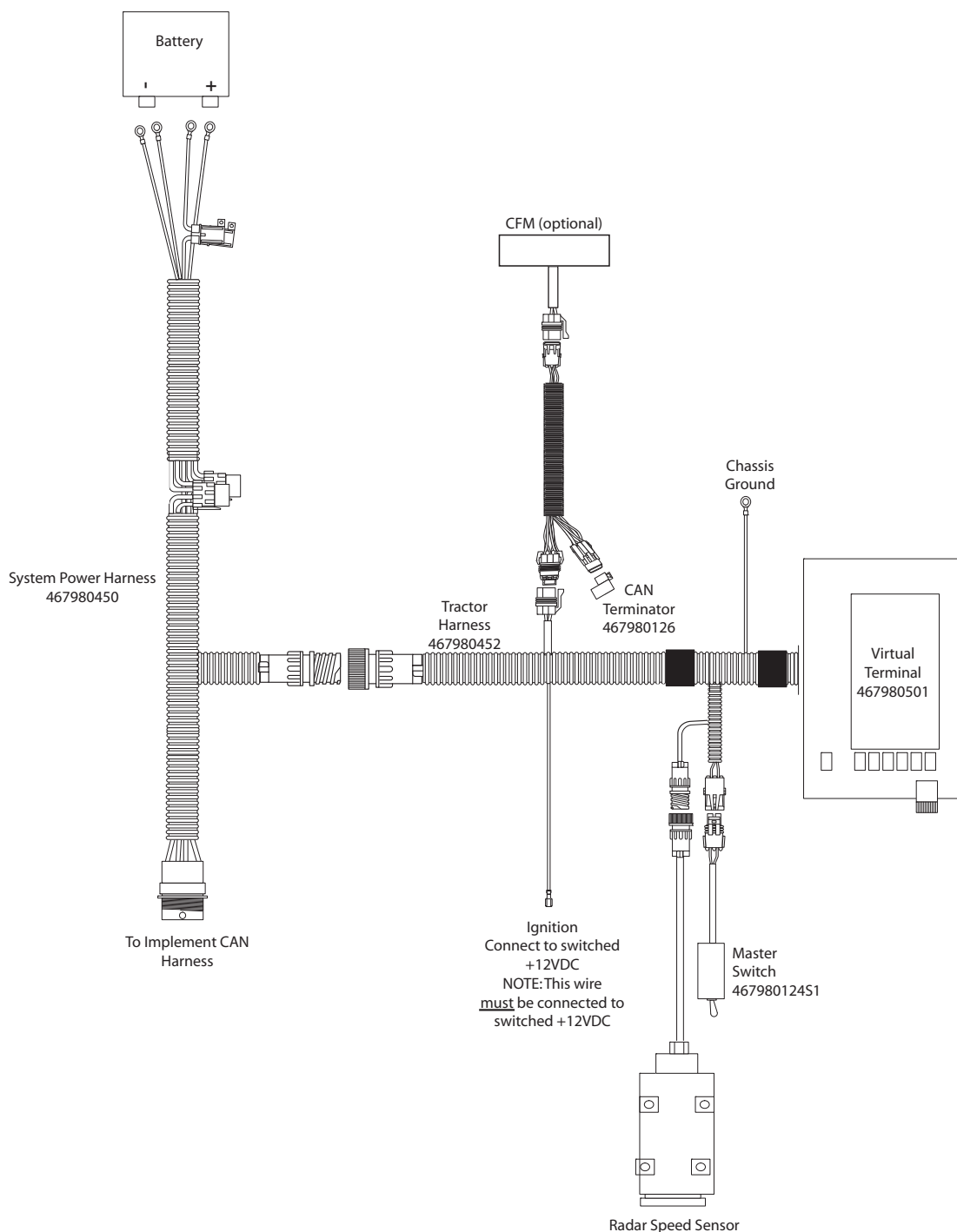


CAB HARNESS CONNECTIONS

The following diagrams illustrate cab harness layout and connections for DICKEY-john 5" and 10" Virtual Terminals.

Figure 13

Cab Harness Layout and Connections (5" Virtual Terminal)





NOTE: The ignition lead must be connected to switched +12VDC for the system to power up and down properly.

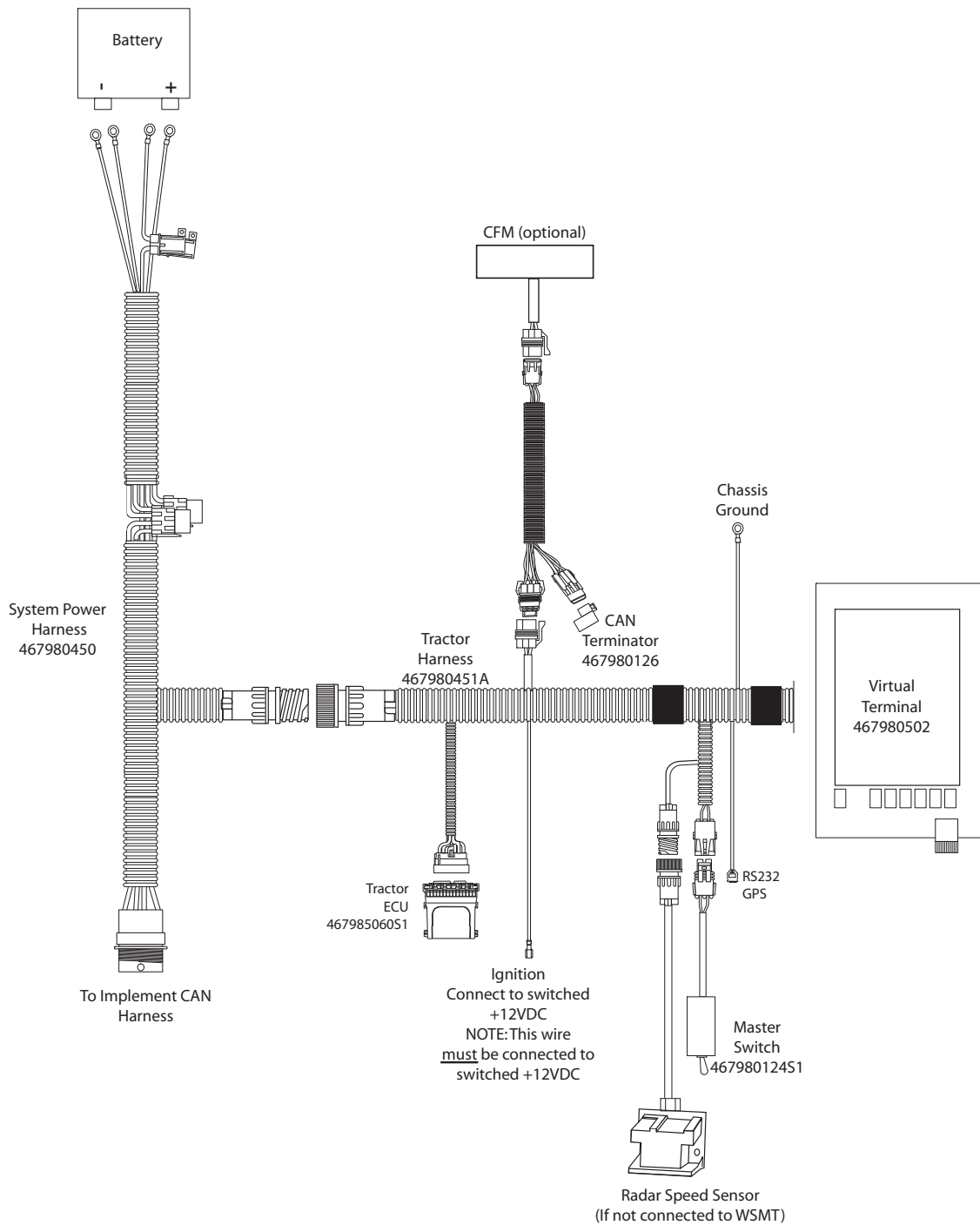
5" VIRTUAL TERMINAL CAB HARNESS CONNECTIONS

1. Connect the power leads directly to the battery.
2. Connect the ignition wire to a switched +12VDC.
3. Connect the Chassis Ground lead to a bare point of the cab frame that offers a good chassis ground connection.
4. Connect the Master Switch, CAN Terminator and Radar Speed Sensor to their respective connectors on the cab harness. If the Speed Sensor is to be connected to the WSMT, do not connect anything to the Speed Sensor connector on the Cab Harness.



Figure 14

Implement Harness Connections (10" Virtual Terminal)





NOTE: The ignition lead must be connected to switched +12VDC for the system to power up and down properly.

10" VIRTUAL TERMINAL CAB HARNESS CONNECTIONS

Connect the power leads directly to the battery.

5. Connect the ignition wire to a switched +12VDC.
6. Connect the chassis ground lead to a bare point of the cab frame that offers a good chassis ground connection.
7. Connect the master switch, CAN terminator, radar speed sensor, GPS, and tractor ECU to their respective connectors on the cab harness. If the speed sensor is to be connected to the WSMT, do not connect anything to the speed sensor connector on the cab harness.

OPERATOR'S MANUAL



Figure 15

Implement Harness

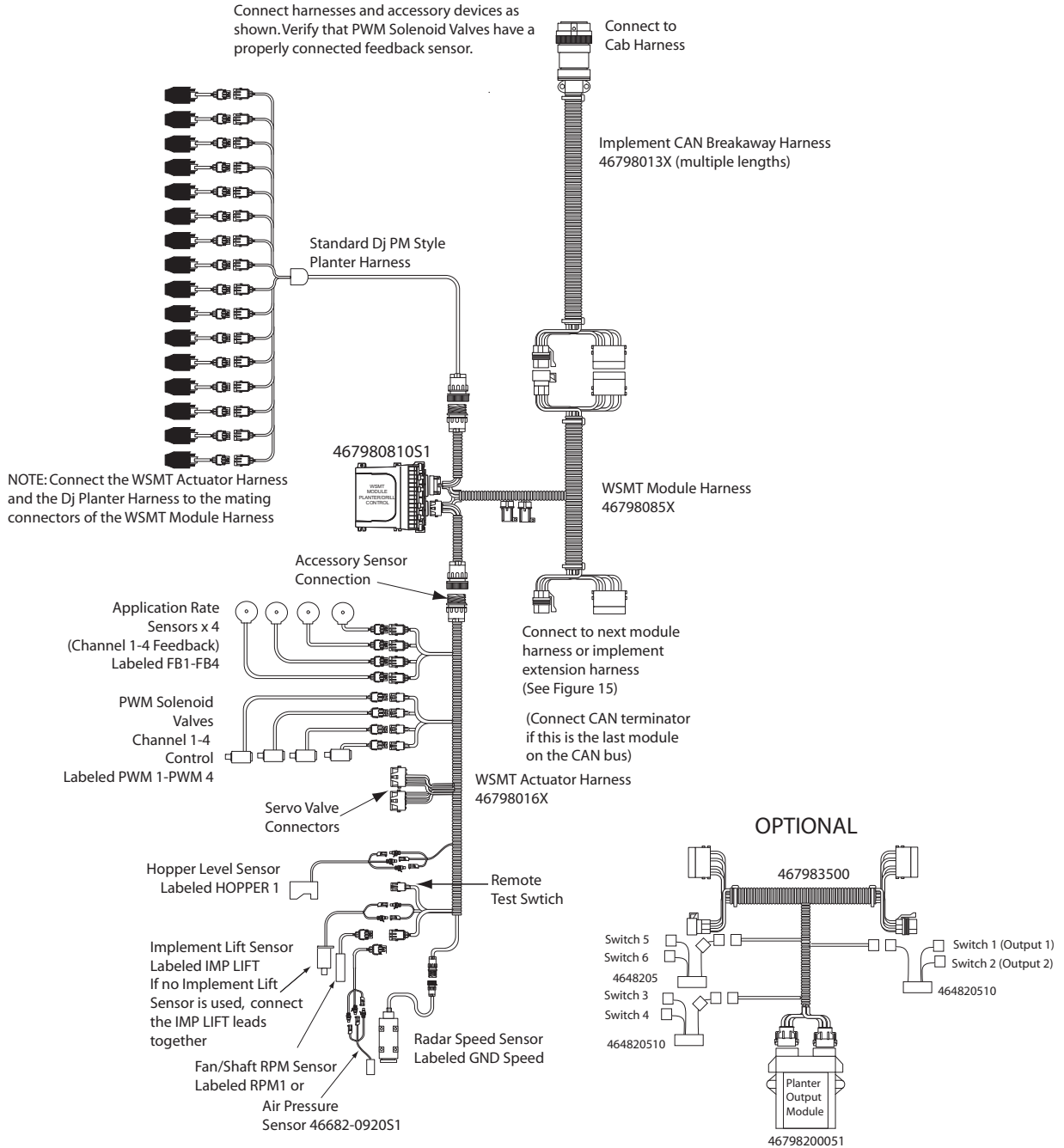
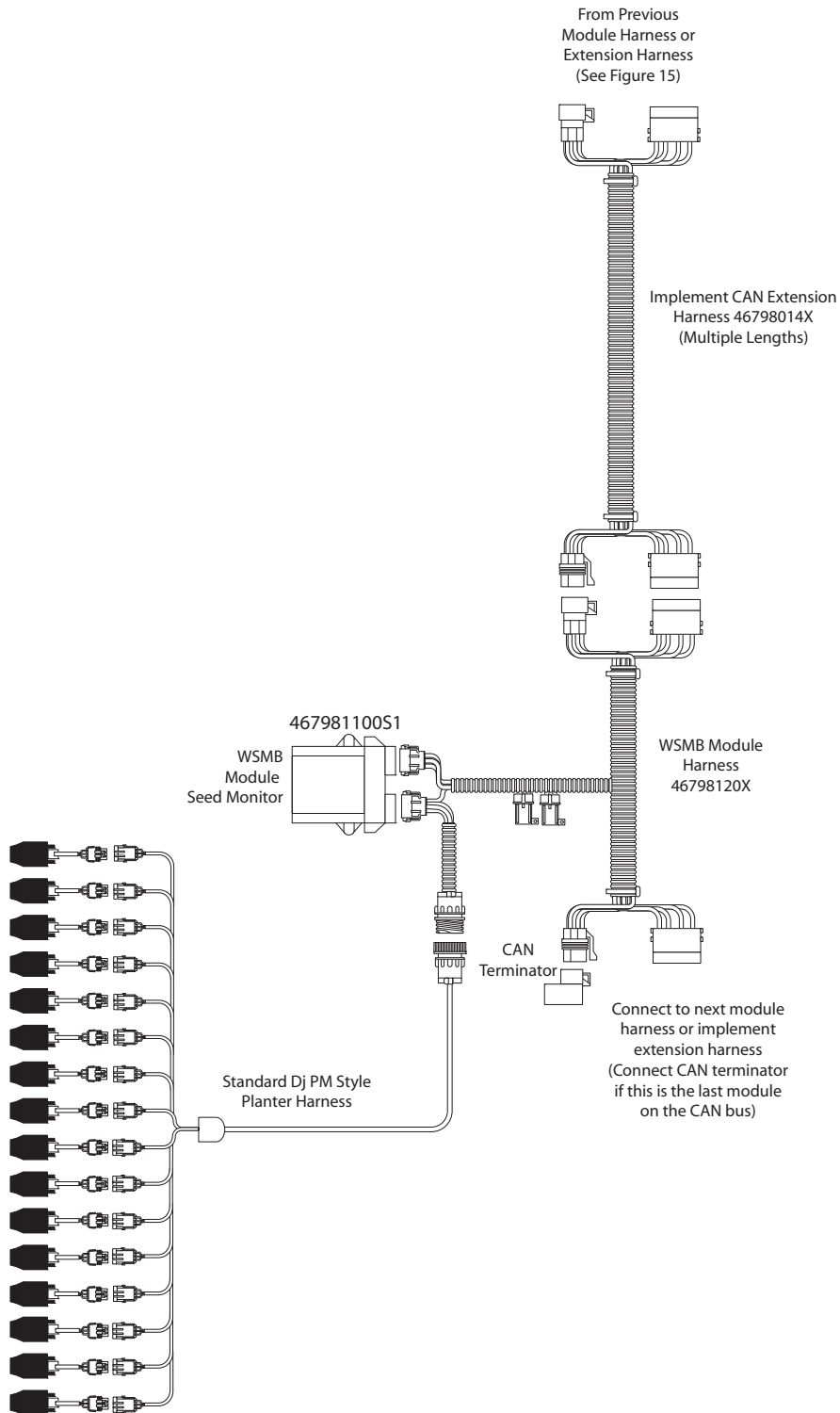




Figure 16

Implement Harness (Continued)





1. Connect the Implement CAN Breakaway extension to the mating connector of the cab harness.
2. Route the harness along the implement hitch to the WSMT module harness (use an implement extension harness if additional length is needed).
3. Secure harness as needed.
4. Connect the module harness to the mating connectors of the Implement CAN harness and then connect the module to the harness. The WSMT module uses a 30 and 18-way connector with a jackscrew to secure the connector to the module. The WSMB uses a pair of 12-pin connectors.
5. Secure module harness as needed.

SENSOR INSTALLATION

For proper system operation, all sensors used with the system must be connected properly as described in the following sections. Sensors that are incorrectly installed will not be properly identified by the system and will result in incorrect numbering of the sensors.

SEED SENSORS

The system is compatible with all existing DICKEY-john seed sensors. Seed sensors may be connected to the WSMT module and all WSMB planter monitor modules. Any number of sensors up to the maximum capacity of the module may be connected. A maximum of 214 seed sensors can be connected to the system.



When connecting seed sensors to the modules, the following requirements must be observed:

All seed sensors installed must be connected to the seed sensor harness SEQUENTIALLY, starting with the Row 1 input. In the event that not all row inputs on the module will be used, the unused inputs must be the last inputs on that module.

Figure 17

Correct Seed Sensor Module Connection

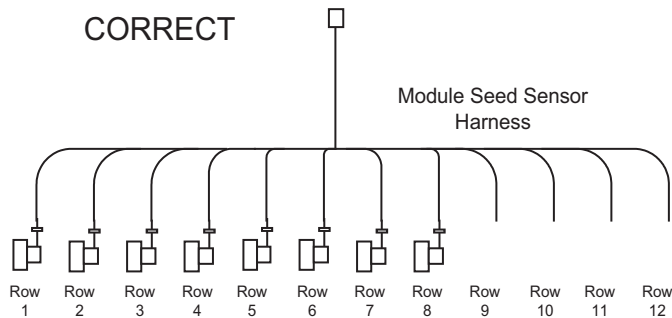
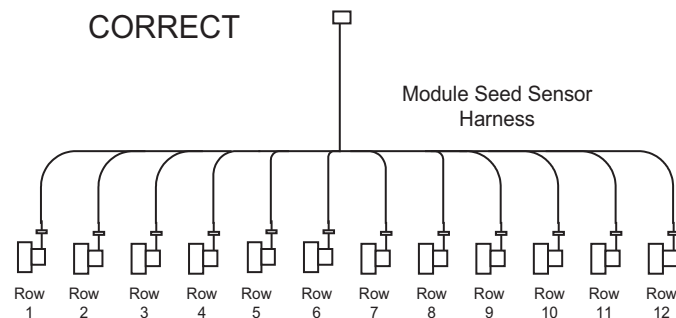
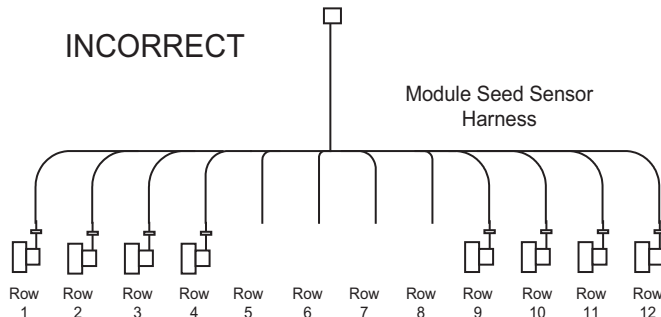


Figure 18

Incorrect Seed Sensor Module Connection



Failure to correctly install seed sensors will result in incorrect row assignment on the planter monitor display functions and alarms.



HOPPER LEVEL SENSORS

The system is compatible with the DICKEY-john planter hopper level sensors. One hopper level sensor may be connected to the WSMT module. The hopper sensor is connected to the actuator harness. The hopper level connection is labeled HOPPER 1.

RPM/FAN SENSORS

The system is compatible with all existing DICKEY-john digital Fan/RPM sensors. One Fan/RPM sensor may be connected to the WSMT module. The sensor is connected to the actuator harness. The Fan/RPM sensor connection is labeled RPM 1.

AIR PRESSURE SENSORS

The system is compatible with DICKEY-john air pressure sensors. One air pressure sensor with adapter harness connects to the RPM harness connection labeled RPM1.





SYSTEM MODES

The Virtual Terminal has two modes of operation:

- Operate
- Setup/Configuration (Setup constants accessible only with password)

The position of the master switch determines which mode is selected.

USER LEVEL ACCESS

The system has two user levels:

- User Level 1: Operator View
- User Level 2: Setup of constants (system configuration)

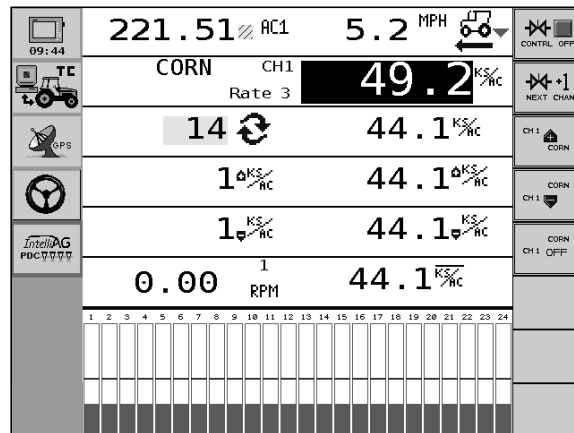
At initial powerup, the system loads in User Level 2. The system can be locked at User Level 1 and will continue to load at this level at every power cycle. A password is required to return to User Level 2 screens.

OPERATE MODE

When the Master Switch is in the ON position, the Virtual Terminal (VT) is in Operate mode. In this mode, all enabled system components and control channels are operational, as well as all monitoring functions and system accumulators.

Figure 19

Operate Mode





AVAILABLE BUTTONS IN OPERATE MODE

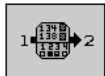
Virtual buttons on the display are used to interact with the system. Top-level buttons that appear on the Operate and Setup/Configuration screens are defined below.

NEXT CHANNEL



The Next Channel button selects the next available channel for changes of rate or to turn channel off. A channel can also be selected by touching the channel on the screen. The active channel can be set to ON or OFF by selecting the On/Off Channel button described below. The active channel is displayed in reverse video display in a multiple channel configuration. The Target Rate for a channel can be adjusted by using the Inc/Dec buttons described below. The channel's Inc/Dec buttons, as well as the ON/OFF buttons, display the current channel label. This key is visible only when multiple channels have been configured.

NEXT WORK SCREEN



The Next Work Screen button displays information on the next configured work screen. The number to the left of the graphic identifies the current screen. The number on the right identifies the next screen to display. The Next Work Screen only displays if multiple screens are configured.

INCREMENT



The Increment button increases the active channel's target rate by the amount specified in the Inc/Dec % or rate table setup for that material. Increment can be pressed several times to increase the target rate by the specified amount for every actuation, until the maximum rate value or preset value is reached. The active channel/material is displayed in the button text.

DECREMENT

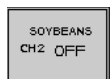


The Decrement button decreases the active channel's target rate by the amount specified in the Inc/Dec% or rate table setup for that material. Decrement can be pressed several times to reduce the target rate by the specified amount for every actuation, until the minimum rate value or preset value is reached. The active channel/material is displayed in the button text.

INC/DEC RESET TO TARGET



The Inc/Dec Reset to Target button is used to return the active channel to the original material target rate. This button is only available for channels that are active and have had the target rate adjusted using the Increment or Decrement buttons in inc/dec % mode. The active channel displays in the button text.



TURN ON/OFF CHANNEL

The Turn On/Off Channel buttons turn the active channel ON and OFF, respectively. Channels that are set to OFF will not operate when the master switch is set to the ON position. Turning a channel OFF is not the same as disabling a channel in Channel Setup Mode. The active channel is displayed in the button text. If the key text is OFF, this is the action that will be performed when the key is pressed.



SUMMARY

The Summary button accesses the Summary screen and provides an overview of system configurations for enabled channels. Specific setup screens can be accessed by pressing inside the yellow boxes for Channel, Material, Row, Module, Speed Set, and Accessory Sensor screens.

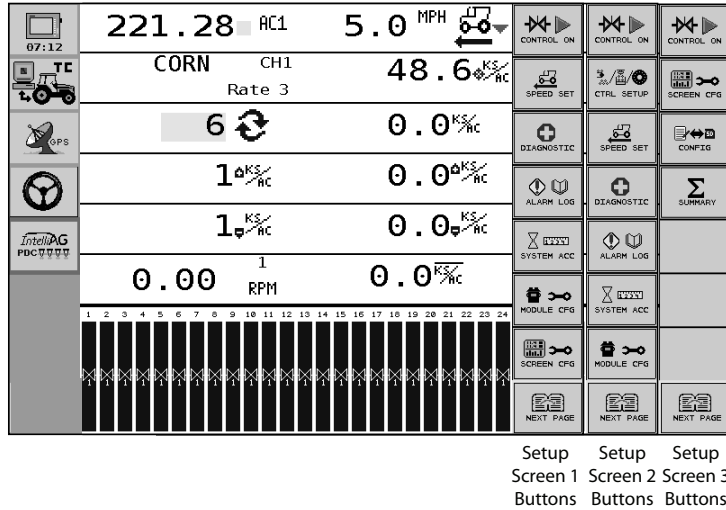


SETUP/CONFIGURATION MODE

When the master switch is in the OFF position, the VT is in Setup/ Configuration mode. In this mode, all control and monitoring functions cease. A password is required to access this mode.

Figure 20

Setup/Configuration Mode



AVAILABLE BUTTONS IN SETUP MODE

Additional buttons for system configuration and parameter setup functions are enabled and only appear in setup/configuration mode. Refer to the System Configuration section for information on these functions.

PLANTER FILL DISK

The Planter Fill Disk button is used to fill the seed meters with seed to allow instant seed flow when the channel is turned ON. Pressing the Fill Disk button rotates the seed meters on **ALL ACTIVE** planter control channels one revolution, then stops. For additional information, refer to the System Configuration section.



ROW MONITOR SETUP

The Row Monitor Setup button accesses the Row Monitor Setup screen. All user-entered constants relating to general planter monitor functions are accessed on this screen.



CONTROL SETUP

The Control Setup button accesses the Control Setup screen. Up to 16 different materials can be configured and stored for planter, liquid, fertilizer, RPM control, and monitor only.





SPEED SET

The Speed Set button accesses the Ground Speed Setup screen. Ground speed is the rate in MPH (Km/h) as measured by the ground speed sensor.



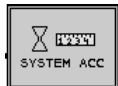
DIAGNOSTICS

The Diagnostics button accesses the Diagnostics screen. Various system operating parameters display on this screen. There is no user-entered data on this screen.



ALARM LOG

The Alarm Log button accesses the Alarm Log screen. An account of the previous alarms issued is stored here. There is no user-entered data on this screen. Not all alarms are recorded in the alarm log.



SYSTEM ACCUMULATORS

The System Accumulators button accesses the System Accumulators screen. All of the system accumulators for time and distance display on this screen. There is no user-entered data on this screen.



MODULE CONFIGURATION

The Module Configuration button accesses the Module Configuration Setup screen. All user-entered data pertaining to module configuration is established on this screen.



SCREEN CONFIGURATION

The Screen Configuration button accesses the Screen Configuration Setup screen. The Virtual Terminal can be customized to display any combination of data items available. Up to three individual display screens can be customized. All work screen configurations are established on this screen.



PLANTER OUTPUT MODULE (POM) CONFIGURATION (OPTIONAL)

The POM Configuration button accesses the POM Setup screen. This screen is only accessible when using a Planter Output Module for clutch/frame control.



CONFIGURATION

The Configuration button accesses the Import/Export Configuration screen. System configurations can be exported to an SD card and imported to other Working Set Masters eliminating manual data entry.





USER LEVELS

The system has two user levels that allow access to certain screens based on user type.

- User Level 1 Operator (Basic View)
- User Level 2 OEM/Dealer (Full Access)

At each powerup, the system loads at the User Level 2 (Full Access) mode.

USER LEVEL 1 OPERATOR (BASIC VIEW)

Operator View (User Level 1) is a restricted level that does not allow any setup/configuration constants to be changed. In operator view the following functions can be performed:

- Perform a fill disk
- Increase and decrease rates
- Access Diagnostics screen
- Enable/disable manual valve
- Access/view Information screen
- Access/view Alarm Log and Detail screens
- Access/view Summary screen for 4 control channels

All other screens for configuring and setup of constants must be performed in Level 2 mode.

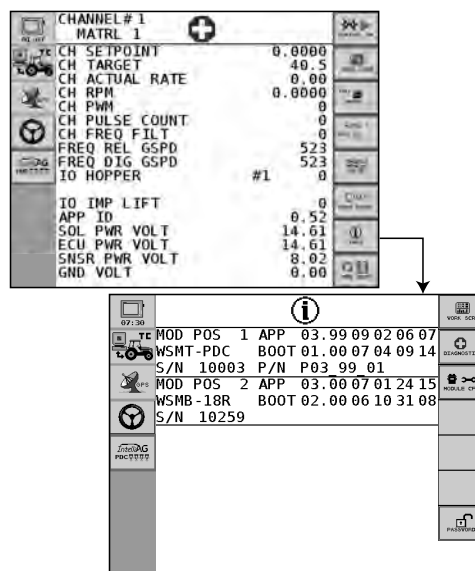
To change to User Level 1 Mode (Basic Operator View):

1. On the IntelliAg Main Work screen, press the **Diagnostics** button.
2. At the Diagnostics screen, press the **Information** button.
3. At the Information screen, press the **Password** button.



Figure 21

Diagnostics and Information Screens

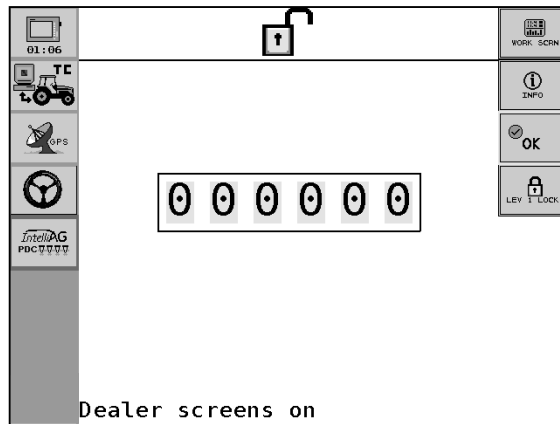




4. At the Password screen, press the **LEV 1 LOCK** button. The LEV 1 LOCK button will disappear from the screen and the system will now operate in Level 1 mode.
5. Press the **Work Screen** button to return to the Main Work screen.

Figure 22

Password Screen/Level 1 Lock Button



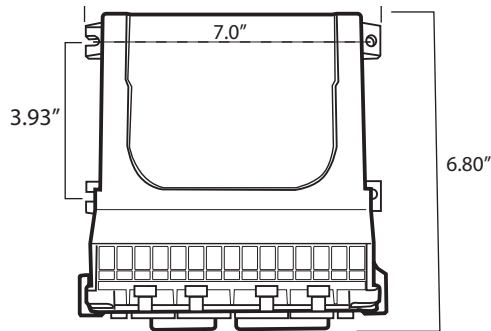
The system will return to the previous set level at each power cycle until changed at the Password screen.

CHANGE OPERATOR LEVEL TO OEM/DEALER LEVEL

To change from operator level to OEM/dealer level, a 6-digit password is required. Password includes the five-digit serial number found on the label of the Working Set Master or on the IntelliAg Information screen.

Figure 23

WSMT Serial Number



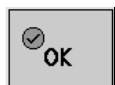
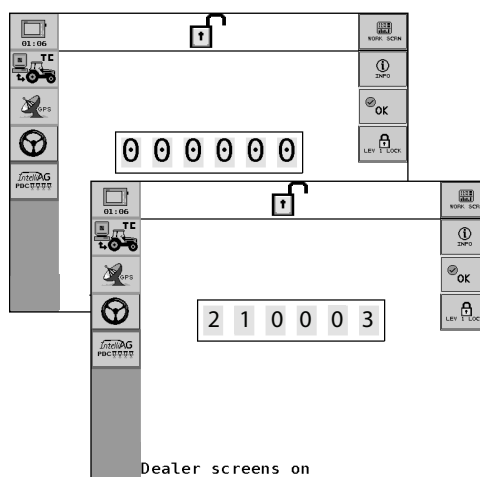
1. On the IntelliAg Main Work screen, press the **Diagnostics** button.
2. At the Diagnostics screen, press the **Information** button.
3. At the Information screen, record serial number of WSMT. 5-digit serial number can also be found on the label of the WSMT.
4. Press the **Password** button.



5. On the Password screen, enter the 6-digit password as follows:
 - Enter the first digit as 2 for User Level 2.
 - For the next five digits, enter the Working Set Master Serial Number taken from the WSMT or Information screen.

Figure 24

Password Screen



6. Press the **OK** button. “Dealer screens on” appears at the bottom of screen confirming the password and that dealer screens are activated.
7. Press the **Work Screen** button to return to the Main Work screen.





SYSTEM CONFIGURATION

The following parameters must be defined for effective system operation:

- Control Channel Setup
- Material Setup
- Ground Speed Setup and Calibration
- Module Configuration (Working Set Master and Members)
- Control Channel Implement Offsets (for GPS and/or field accumulators)

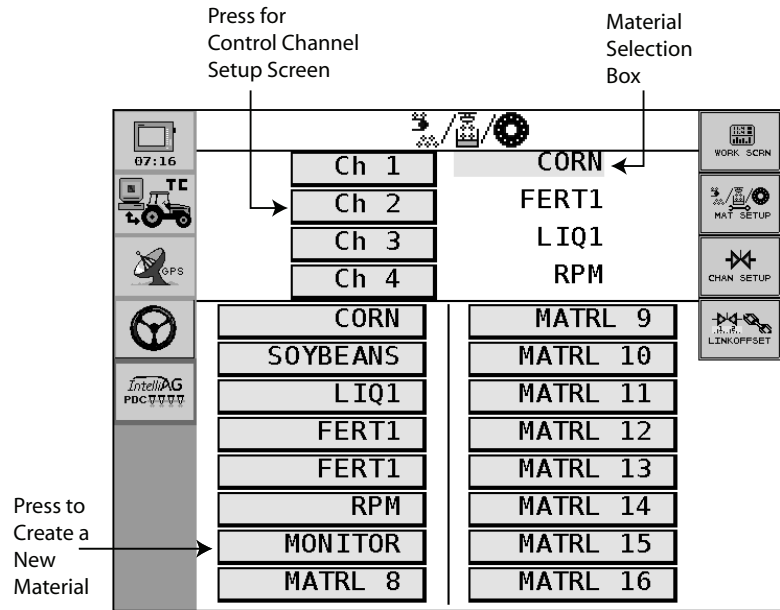
CONTROL SETUP OVERVIEW

The Control Setup screen provides an overview of all materials that have been assigned and configured for a control channel.

The Control Setup screen has control channel selection at the top of the screen and all assigned and unassigned material names at the bottom half of the screen. (Figure 25) shows channel 1 set to apply corn (planter control), channel 2 (fertilizer), channel 3 (liquid), and channel 4 (RPM).

Figure 25

Control Setup Screen



MATERIAL/CHANNEL SETUP STEPS

Materials must be assigned to a planting, liquid, granular seed, granular fertilizer, RPM, or monitor only type control channel. Once a material's designation is established, it can be assigned to one of four control channels.

For operator convenience, it is recommended that materials and channels be established in the following order (refer to Figure 26):



1. Material Configuration Setup--Create all material types that will be assigned to a control channel.
2. Control Channel Setup-Configure control channels as Planter, Liquid, Granular Seeding, Granular Fertilizer, or RPM control.
3. Control Setup Screen--Channels and materials can be selected on this screen. Selecting an unassigned material button allows a new material to be created and assigned to a channel.

Figure 26

Recommended Steps for Material/Channel Setup

Step 1:
Material Setup

Step 2:
Channel Setup

Step 3:
Material Library Screen



CONTROL CHANNEL AND MATERIAL SELECTION

Channels 1 through 4 located at the top of the Control Setup screen identifies the current material assigned to a specific channel. If more than one material is configured for a channel, the control channel's material will appear in a yellow highlight box.

To change a control channel material:

1. From the Control Setup screen, press the Material Selection box for the control channel (Figure 25).
2. Use the left and right arrows to scroll through available materials.
3. Press the check mark to select the new material or 'X' to cancel.
4. The material appears on the Control Setup screen as the active material.

If there is only one material or control type established that channel's material is not selectable from the Control Setup screen.

Channel/Material Assignment is identified as follows:

- Channel 1-4 Active Channel/Material: The active material assigned to a channel appears at the top of the display.
- No Material Selected: If no material matches the channel type, the channel displays on the Material Library screen as None. A material can be configured for the channel by selecting an available material at the Control Setup Screen.
- Disabled: If a channel is disabled from the Channel Setup screen, the channel displays as Disabled. The channel is turned OFF and is not configured for operation. To establish a new channel, select the **Channel Setup** button.

MATERIAL ASSIGNMENT (MATRL 1-16)

Up to 16 different material names display on the Control Setup screen. Unassigned materials appear on the Material button with a generic name, MATRL1. Materials should be given a name that clearly identifies the material type.

As materials are configured and saved, the Material buttons on the Control Setup screen changes to the name created at the Material Setup screen. The Material Setup screen can be accessed at any time by pressing the Material Name button. Refer to the Material Setup section for further instructions.



MATERIAL SETUP

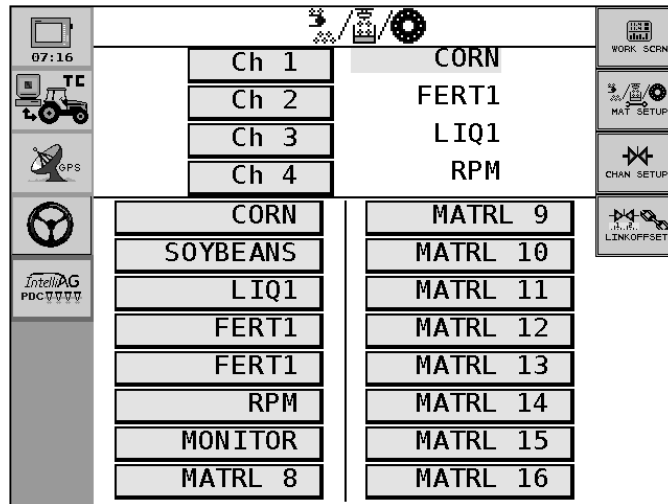
Up to 16 different materials can be configured for Planter, Liquid, Granular Seeding, Granular Fertilizer, or RPM control.

At the Control Setup screen:

1. Select a material by pressing one of the Material 1 through 16 buttons to display the Control Setup screen.

Figure 27

Control Setup Screen



CREATE A MATERIAL NAME

Each material name can be customized to accurately define the material's type. Creating a name allows for quick identification at the Control Setup screen and will display throughout various screens to identify the active material assigned to a channel.

To Edit the Material Name:

1. At the Material Setup screen, press the Material Name Input box as shown in (Figure 28) to display the virtual keypad.
2. Type in a material name and press the checkmark to save or the 'X' to cancel. Available characters are a combination of upper case, numbers, letters, symbols, and spaces.

Figure 28

Edit Material Name at Material Setup Screen

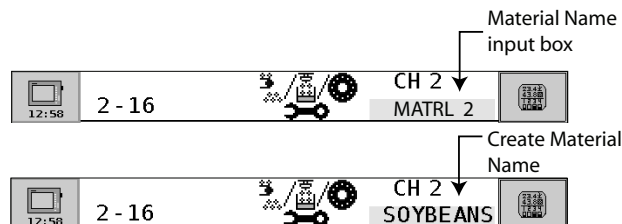
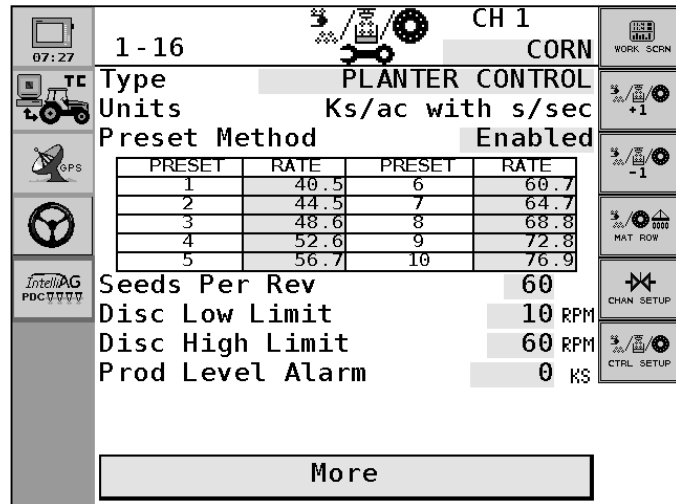




Figure 29
Material Setup screen



TYPE

Type establishes the desired type of application control channel used for a specific material. **This step is very important. The Material Type must correctly match the Control Type for material selection from the Control Setup screen to operate properly.**

Type	Use for
Planter Control	seeding on a row crop planter
Granular Seeding	seed control on a drill or air cart
Granular Fertilizer	granular application control, air cart, or spreader
Liquid Flow	liquid application control
Monitor Only	population monitoring only
RPM Control	monitors fan/shaft speed

UNITS

Automatically changes with the type of material application selected.

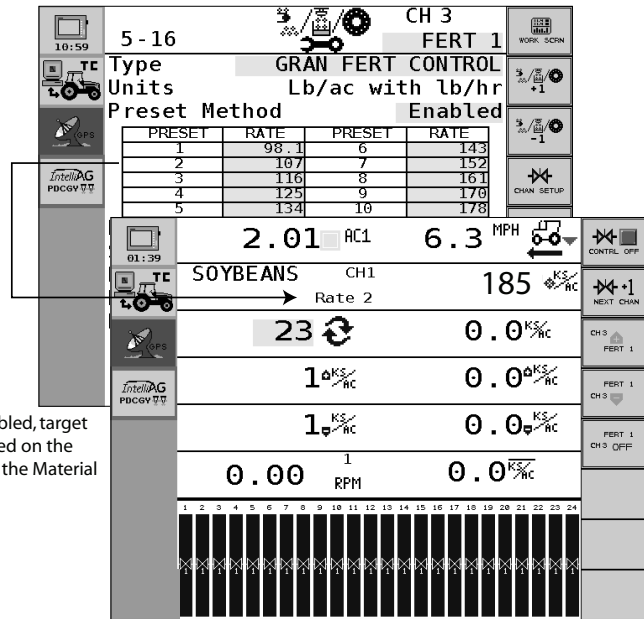
PRESET METHOD ENABLED

The Preset Method table allows user-defined target rates to be entered. When enabled, target rates can be adjusted from the Main Work screen using the **Increment and Decrement** buttons. Up to 10 preset target rates can be configured.





Figure 30
Material Setup Screen-Preset Method Enabled



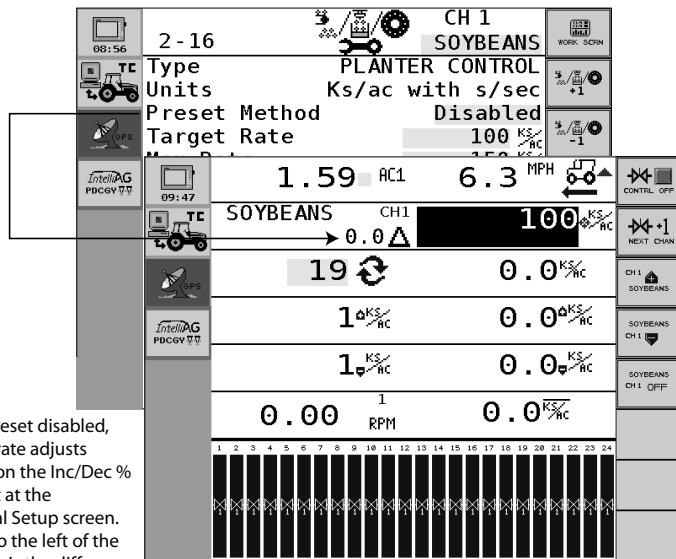
With Preset enabled, target rate adjusts based on the rates entered at the Material Setup screen.

PRESET METHOD DISABLED

When the Preset Method is disabled, the target rate on the Main Work screen can be adjusted by pressing the Material Increment/Decrement buttons. The target rate will increase or decrease based on the Inc/Dec % value set at the Material Setup screen.

NOTE: Rate changes can only occur on actively viewed control channels.

Figure 31
Material Configuration Setup Screen-Preset Method Disabled



With Preset disabled, target rate adjusts based on the Inc/Dec % rate set at the Material Setup screen. Value to the left of the triangle is the difference off of target rate.



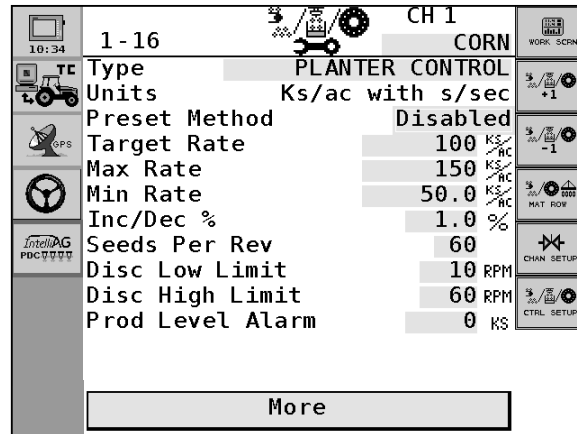
MATERIAL SETUP CONSTANTS - PLANTER CTRL

Material setup parameters for Planter Control.

NOTE: Refer to Control Setup to link a material to a channel.

Figure 32

Planter Control Setup Screen - Preset Method Disabled



TARGET RATE

Target Rate establishes the desired rate of application in KS (thousand) seeds per acre or (KS/Ha).

MAX RATE

Maximum Rate establishes the maximum application rate in KS (thousand) seeds per acre or (KS/Ha) that the control will allow. Target Rate cannot be incremented to a value greater than this established Max Rate.

MIN RATE

Minimum Rate establishes the minimum application rate in KS (thousand) seeds per acre or (KS/Ha) that the control will allow. Target Rate cannot be decremented to a value lower than this established Min Rate.

INC/DEC %

The Increment/Decrement percent rate establishes the percentage of change of the entered target rate that is applied each time the **Material Increment/Decrement** button is pressed on the Main Work Screen.

IMPORTANT: The Maximum or Minimum Rates may not be reached if the % increase or decrease, based off the Target Rate, exceeds the maximum or minimum rate limits set.

EXAMPLE: Maximum Rate is set for 101. Target Rate is set for 100. If the % increase is set at 2%, the maximum rate of 101 will not be met because the % increase of 2% would exceed the 101 maximum rate limit.





SEEDS PER REV

Seeds Per Rev displays the number of seeds that are dropped in one revolution of the seed disk.

DISC HIGH LIMIT

Disc High Limit establishes the maximum RPM at which the seed disc will operate. The control will not allow the seed disc to rotate faster than the Disc High Limit setting.

DISC LOW LIMIT

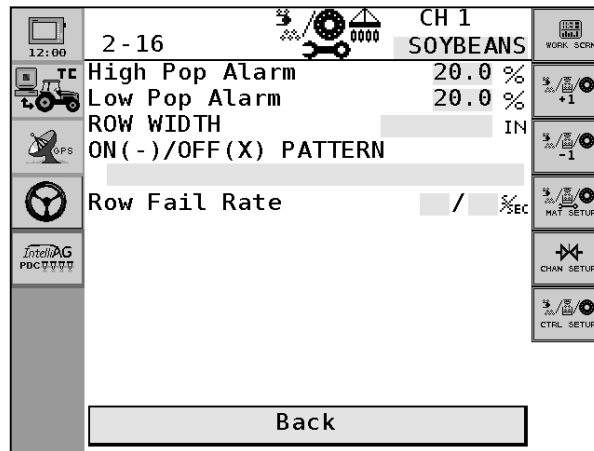
Disc Low Limit establishes the minimum RPM at which the seed disc will operate. The control will not allow the seed disc to rotate slower than the Disc Low Limit setting.

PROD LEVEL ALARM

The Product Level alarm sets the level to trigger an alarm alerting of low product levels. The entered value is an estimate volume.

Figure 33

Planter Control Setup Screen - Preset Method Disabled



HIGH AND LOW POPULATION ALARM

The High and Low Alarm option sets the high and low population limit values. The limit can be set to 0.0 to disable the population alarms. The entered value is dependent on the target rate.

- The High and Low Alarms are entered as a percentage. The percentage value is referenced in relation to the current channel target rate setting if rows are assigned to a channel. Otherwise the alarm will trigger from planter average population.

High Alarm example:

If the Target Rate is 100.0 and the High Alarm is 5.0%, multiply 100.0 x 1.05 (a 5% increase) = 105.0. The alarm will activate at this population.



Low Alarm example:

If the Target Rate is 100.0 and the Low Alarm is 5.0%, multiply 100.0 x .95 (a 5% decrease) = 95.0. The alarm will activate at this population.

ROW WIDTH

Row Width is used for seed rate data and is the distance in inches (centimeters) between rows with a resolution of 0.1. This value updates automatically with changes in the On/Off Pattern Setting option if the Auto Update Width option is set to Enabled.

IMPORTANT: Row Width and On/Off Patterns can be set at the Material Setup screen or the Row I/O screen. The system will use the last entered constants from either screen. However, it is recommended that patterns are set for each material at the Material Setup screen.

ON/OFF PATTERN

For split, twin, or skip row type seeding implements there are 21 predefined patterns to configure row patterns. When a row pattern is selected, all of the rows are automatically turned ON or OFF according to the pattern. Individual rows in the Row Setup screen can still be manually edited to Population, Blockage, or off before or after a pattern is selected. The pattern setting, when selected, will override previous individual existing row settings.

ROW FAIL RATE

The Row Fail Rate value sets the threshold for Row Failure alarms. The value is entered in seeds per second. Both values are adjustable, allowing for numerous combinations. The default value is 2/1, which indicates a row failure threshold of 2 seeds in 1 second.



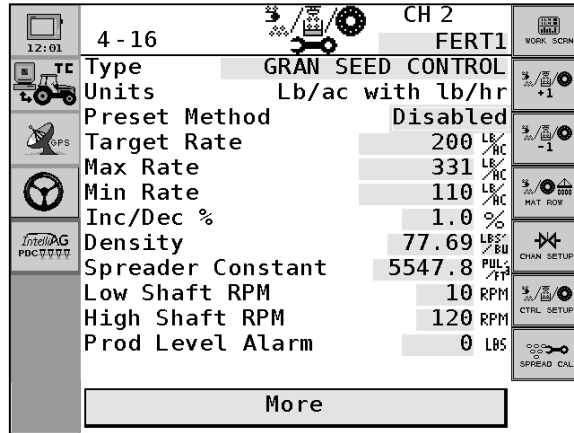
MATERIAL SETUP CONSTANTS-GRAN SEED AND GRAN FERTILIZER CONTROL

Material Setup parameters for Granular Seed and Granular Fertilizer using hydraulic control systems.

NOTE: Refer to Control Setup to link a material to a channel.

Figure 34

Granular Seeding Material Setup Screen



NOTE: Additional Material Setup screen, selected by pressing 'More', only applies to Granular Seed Control; not Granular Fertilizer.

TARGET RATE

Target Rate establishes the desired rate of application in pounds per acre (kg/Ha).

MAX RATE

Maximum Rate establishes the maximum application rate in pounds per acre (kg/Ha) that the control will allow. Target Rate cannot be incremented to a value greater than this established maximum rate.

MIN RATE

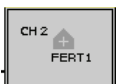
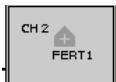
Minimum Rate establishes the minimum application rate in pounds per acre (kg/Ha) that the control will allow. Target Rate cannot be decremented to a value lower than this established minimum rate.

INC/DEC %

The Increment/Decrement percent rate establishes the percentage of change of the entered target rate that will be applied each time the **Increment/Decrement** button is pressed on the Main Work Screen.

IMPORTANT: The maximum or minimum rates may not be reached if the % increase or decrease, based off the Target Rate, exceeds the maximum or minimum rate limits set.

EXAMPLE: Maximum Rate is set for 101. Target Rate is set for 100. If the % increase is set at 2%, the maximum rate of 101 will not be met because the % increase of 2% would exceed the 101 maximum rate limit.





DENSITY

Density is the weight per volume of material to be dispensed and is required to convert the spreader constant. If density is unknown, a value of 1 can be entered to perform a spreader constant. This will place the channel into a pure pulse/ft³ granular system.

SPREADER CONSTANT

Spreader Constant establishes the value for the amount of material per pulse of the application rate sensor. The value entered defines the pulses from the feedback sensor per ft³ of material discharged. Each material (and gate setting as applicable) has its own spreader constant. For best results, the value must be as accurate as possible. **This value may be set manually, however, using the Spreader Constant Calibration is recommended for the most accurate results.**

LOW SHAFT RPM

Low Shaft RPM establishes the low shaft RPM at which the meter shaft will operate. Low shaft RPM is the lowest shaft RPM speed that the control channel will operate.

HIGH SHAFT RPM

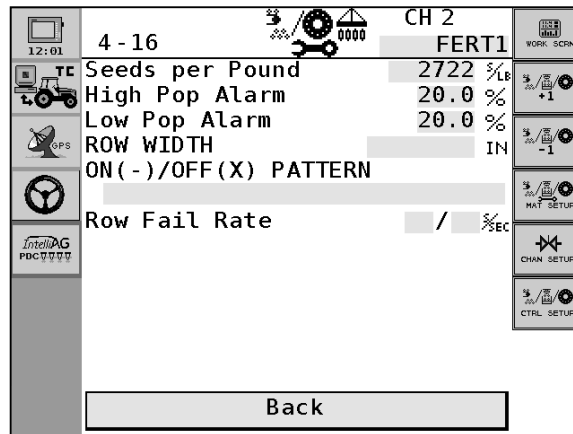
High Shaft RPM establishes the high shaft RPM at which the meter shaft will operate. High shaft RPM is the highest shaft RPM that the control channel will operate.

PROD LEVEL ALARM

The product level alarm sets the weight (lbs/Kg) to alert of low seed levels. The entered value is an estimate in lbs.



Figure 35
Granular Seeding Material Setup Screen



NOTE: Additional Material Setup screen, selected by pressing 'More', only applies to Granular Seed Control; not Granular Fertilizer.

SEEDS PER POUND

The number (#) of seeds per pound is the value used to convert the current application rate to KS/AC to determine population and population alarms.

HIGH AND LOW POPULATION ALARM

The High and Low Alarm option sets the high and low population limit values. The limit can be set to 0.0 to disable the population alarms. The entered value is dependent on the target rate.

- The High and Low Alarms are entered as a percentage. The percentage value is referenced in relation to the Target Rate x seed/lb setting.

High Alarm example

If the Target Rate is 100.0 x 3,000 seed/lb and the High Alarm is 5.0%, multiply 300,000 KS/AC x 1.05 (a 5% increase) = 315 KS/AC. The alarm will activate at this rate.

Low Alarm example

If the Target Rate is 100.0 x 3,000 seed/lb and the Low Alarm is 5.0%, multiply 300,000 x 0.95 (a 5% decrease) = 285 KS/AC. The alarm will activate at this rate.

ROW WIDTH

Row Width is used for seed rate data and is the distance in inches (centimeters) between rows with a resolution of 0.1. This value updates automatically with changes in the On/Off Pattern Setting option if the Auto Update Width option is set to Enabled.

IMPORTANT: Row Width and On/Off Patterns can be set at the Material Setup screen or the Row I/O screen. The system will use the last entered constants from either screen. However, it is recommended that patterns are set for each material at the Material Setup screen.



ON/OFF PATTERN

For split, twin, or skip row type seeding implements there are 21 predefined patterns to configure row patterns. When a row pattern is selected, all of the rows are automatically turned ON or OFF according to the pattern. Individual rows in the Row Setup screen can still be manually edited to Population, Blockage, or off before or after a pattern is selected. The pattern setting, when selected, will override previous individual existing row settings.

ROW FAIL RATE

The Row Fail Rate value sets the threshold for Row Failure alarms. The value is entered in seeds per second. Both values are adjustable, allowing for numerous combinations. The default value is 2/1, which indicates a row failure threshold of 2 seeds in 1 second.



MATERIAL SETUP CONSTANTS-LIQUID FLOW

Material Setup for Liquid Flow control.

NOTE: Refer to Control Setup to link a material to a channel.

Figure 36

Liquid Flow Material Setup Screen

12:01	1 - 16	CH 3	LIQUID	WORK SCREEN
TC	Type	LIQUID FLOW CONTROL		% / [] +1
Tractor	Units	Gal/ac with gal/min		
GPS	Preset Method	Disabled		
	Target Rate	23.9	GAL / AC	% / [] -1
	Max Rate	39.6	GAL / AC	
	Min Rate	13.2	GAL / AC	
	Inc/Dec %	1.0	%	CHAN SETUP
IntelliAG PDC	Low Flow Limit	3	GAL / MIN	% / [] CTRL SETUP
	High Flow Limit	32	GAL / MIN	
	Prod Level Alarm	0	GAL	

TARGET RATE

Target Rate establishes the desired rate of application in gallons per acre (Liters/Ha).

MAX RATE

Maximum Rate establishes the maximum application rate in gallons per acre (Liter/Ha) that the control will allow. Target Rate cannot be incremented to a value greater than this established maximum rate.

MIN RATE

Minimum Rate establishes the minimum application rate in gallons per acre (Liter/Ha) that the control will allow. Target Rate cannot be decremented to a value lower than this established minimum rate.

INC/DEC %

The Increment/Decrement Percent rate establishes the percentage of change that will be applied each time the **Increment/Decrement** button is pressed on the Main Work Screen.

IMPORTANT: The maximum or minimum rates may not be reached if the % increase or decrease, based off the Target Rate, exceeds the maximum or minimum rate limits set.

EXAMPLE: Maximum Rate is set for 101. Target Rate is set for 100. If the % increase is set at 2%, the maximum rate of 101 will not be met because the % increase of 2% would exceed the 101 maximum rate limit.





LOW FLOW LIMIT

The Low Flow Limit sets the lowest gallon per minute flow rate which the control channel will operate.

HIGH FLOW LIMIT

The High Flow Limit set the highest gallon per minute flow rate which the control channel will operate.

PRODUCT LEVEL ALARM

The Product Level alarm sets the gallons left in the tank to trigger an alarm alerting of low liquid levels. The entered value is an estimate in gallons.



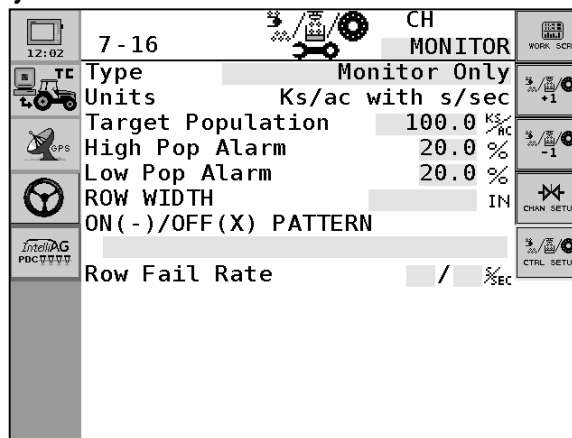
MATERIAL SETUP - MONITOR ONLY

The Monitor Only selection is typically used for ground drive applications to monitor population with high and low alarms. All seeding control channels **MUST** be disabled in this configuration and/or no rows assigned to those seeding channels.

IMPORTANT: A material name must be selected at the Row Monitor Setup screen to activate high and low population alarms.

Figure 37

Monitor Only Screen



TYPE

Select Monitor Only as the Channel Type.

TARGET POPULATION

Target population is defined in 1000s of seeds per acre or hectare.

HIGH AND LOW POPULATION ALARMS

The High Population and Low Population values determine when an alarm and row indicator displays to warn of a population problem. The values are % based. The high population and low population values are independent of each other and do not have to be the same percentage value.

ROW WIDTH

Row Width is used for seed rate data and is the distance in inches (centimeters) between rows with a resolution of 0.1. This value updates automatically with changes in the On/Off Pattern Setting option if the Auto Update Width option is set to Enabled.



IMPORTANT: Row Width and On/Off Patterns can be set at the Material Setup screen or the Row I/O screen. The system will use the last entered constants from either screen. However, it is recommended that patterns are set for each material at the Material Setup screen.

ON/OFF PATTERN

For split, twin, or skip row type seeding implements there are 21 predefined patterns to configure row patterns. When a row pattern is selected, all of the rows are automatically turned ON or OFF according to the pattern. Individual rows in the Row Setup screen can still be manually edited to Population, Blockage, or off before or after a pattern is selected. The pattern setting, when selected, will override previous individual existing row settings.

ROW FAIL RATE

The Row Fail Rate value sets the threshold for Row Failure alarms. The value is entered in seeds per second. Both values are adjustable, allowing for numerous combinations. The default value is 2/1, which indicates a row failure threshold of 2 seeds in 1 second.



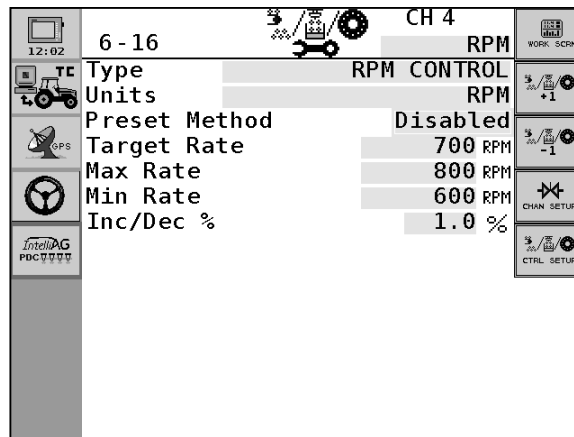
MATERIAL SETUP CONSTANTS - RPM CONTROL

The following constants on the Material Configuration Setup screen define the parameters for RPM control.

NOTE: Refer to Channel Setup to link a material to a channel.

Figure 38

RPM Control Material Setup Screen



TARGET RATE

Target Rate establishes the desired rate of RPM.

MAX RATE

Maximum Rate establishes the maximum RPM the control will allow. Target Rate cannot be incremented to a value greater than this established maximum rate.

MIN RATE

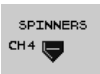
Minimum Rate establishes the minimum RPM the control will allow. Target Rate cannot be decremented to a value lower than this established minimum rate.

INC/DEC %

The Increment/Decrement percent rate establishes the percentage of RPM change each time the **Increment/Decrement** button is pressed on the Main Operate screen.

IMPORTANT: The maximum or minimum rates may not be reached if the % increase or decrease, based off the target rate, exceeds the maximum or minimum rate limits set.

EXAMPLE: Maximum Rate is set for 101. Target Rate is set for 100. If the % increase is set at 2%, the maximum rate of 101 will not be met because the % increase of 2% would exceed the 101 maximum rate limit.





CONTROL CHANNEL SETUP

Channel Setup allows configuration of 4 independent control channels. Control channel choices consist of:

1. Planter Control
2. Granular Fertilizer
3. Granular Seeding
4. Liquid Flow
5. RPM Control
6. Disabled

A control channel identified as Disabled indicates the channel is not in use.

Control channel parameters that can be configured include:

- Control Mode
- Drive Type
- Drive Frequency
- Input Filter
- Gear Ratio (except Liquid Flow)
- Sensor Constant
- # Seed Rows (Planter Control only)
- Channel Width
- Precharge Time
- Delay Time
- Flush Time

Once a material has been created and linked to a channel type, that material is automatically assigned to the corresponding channel.

To establish a Control Channel:

1. At the Control Setup screen, press the **Channel Setup** button to display the Channel Setup screen.



Refer to the appropriate control channel section for configuring constants.

To configure more than one control channel, press the **Next Channel** button.



IMPORTANT: It is recommended that Materials are created before configuring channels on the Channel Setup screen.



PLANTER CONTROL SETUP

Use this section for setting a channel to control the application rate of a row crop planter.

Figure 39

Control Channel Setup - Planter Control

07:28	CHANNEL# 1		WORK SCR	5 REV
	Type	PLANTER CONTROL		CALIB PARAM
	Material Name	CORN		
	Control Mode	Auto		
	Drive Type	PWM 1		
	Drive Freq.	100 HZ		
	Input Filter	50 %		
	Gear Ratio	1.000		
	Sensor Constant	360 PUL/REV		
	# Seed Rows	34		
	Seed Rows	1 - 34		
	Channel Width	1020.0 IN		
	PreCharge(+)\Delay(-)	0.0 SEC		

TYPE

Select Planter Control as the Channel Type.

MATERIAL NAME

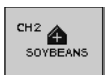
The Material Name displays only when a material is configured for the same channel type.

CONTROL MODE

AUTO-Control Channel is calculating application rates based on ground speed and row spacing under normal operating conditions.

MANUAL W/FEEDBACK-Overrides the current system when not operating properly, i.e., faulty coil. Using the **Increment/Decrement** buttons at the Main Operate screen will set the rate for the control channel. Manual Mode with Feedback will show the actual application rate being applied based on actual ground speed and constants.

MANUAL W/O FEEDBACK-Overrides the current system when not operating properly, i.e., bad feedback sensor. Using the **Increment/Decrement** buttons at the Main Work screen will set the flow rate for the control channel. No application rate feedback will display.





DRIVE TYPE

PWM (Pulse Width Modulation)

A valve, usually hydraulic, which varies the oil flow to a hydraulic motor proportioned to electric current supplied. This type of valve consists of a flow cartridge and coil assembly.

DRIVE FREQUENCY

Drive Frequency specifies the frequency for the proportional valve being used. The recommended setting for this option should be specified from the specific valve manufacturer.

NOTE: DICKEY-john proportional valves operate at 100 hz.

Input Filter

The Input Filter provides a setting for the amount of filtering applied to the feedback frequency feedback of the control channel.

IMPORTANT: It is NOT recommended that the Input Filter be manually altered. Any adjustments could result in the channel not operating properly. If adjustments are made, a valve calibration must be performed.

NOTE: The correct number of pulses generated for one revolution must be determined for sensors other than DICKEY-john.

SENSOR CONSTANT

Sensor Constant establishes the number of pulses for one revolution of the application rate sensor. If a standard DICKEY-john application rate sensor is used, the value should be set to 360.0.

GEAR RATIO

Gear Ratio specifies the actual ratio from the **application rate** sensor to the **seed meter**. This specifies the number of revolutions the application rate sensor turns in relation to one revolution the seed meter turns.

NUMBER (#) OF SEED ROWS

Allows entry of a specific number of seed rows to the control channel. Row assignment is given a priority based on the channel and will be assigned sequentially thereafter. Channel 1 will always be assigned to the first set of rows, Channel 2 the next set of rows, and so on. This will disable the row alarms when a respective channel is turned off.

CHANNEL WIDTH

Channel Width is the width for rows assigned to a specific channel. Width calculation can be determined by number of planter rows assigned to the channel multiplied by the row spacing.

PRECHARGE TIME

Precharge Time is a specified length of time a control channel will operate or be active with a minimum precharge ground speed greater than 0 (Refer to the Ground Speed Setup section for Precharge Ground Speed setup information). This feature will activate the control when the master switch is turned ON even without ground speed.



The precharge feature is typically used in applications that have significant distance between the implement row unit and storage bulk tank where seed placement takes several seconds due to the travel time of the seed/fertilizer from the bulk tank to the ground.

The precharge feature will operate until the precharge time lapses or the precharge ground speed has been exceeded. If the master switch is turned OFF, the precharge feature will abort.

A Precharge Alarm will display any time the preset feature is established or changed and the master switch is turned ON.

IMPORTANT: A Precharge number MUST be entered as a positive number (5.0 seconds) for the system to identify between a Precharge or Delay Time state.

To activate Precharge:

1. At the Control Channel screen, enter a Precharge time. A Precharge Time must be entered as a **POSITIVE** number (5.0 seconds) before the Precharge Ground Speed feature displays on the Ground Speed Setup screen (Refer to Ground Speed Setup section).
2. Press the **Main Work** button and select the **Speed Set** button.
3. Enter a Precharge Ground Speed greater than 0.

IMPORTANT: Turn the master switch ON to activate the Precharge feature.

Delay Time

IMPORTANT: A Delay Time number MUST be entered as a negative number (-5.0 seconds) for the system to identify between a Delay Time or Precharge state.

With an Implement Lift Switch

Delay Time determines the length of time before the control channel will start after the master switch has been turned ON and the implement switch is in a lowered position.

- The system will **immediately** shutdown the channel when the implement lift switch is in the raised position.
- The system will delay the channel shutdown if the master switch is turned OFF and the implement is in the down position.



NOTE: Delay Time functionality may work differently than described above if the system has been purchased direct from the original equipment manufacturer. Refer to the manufacturer's operator manual for further instruction.



Without an Implement Lift Switch

When the Delay Time feature is utilized without an implement lift switch:

- The control channel will delay after the master switch has been turned ON.
- A delay will also occur and then shutdown the control channel when the master switch is turned OFF.

FLUSH ENABLE

Flush Enable is a manual override mode that opens the valve and dispenses granular fertilizer, granular seed, or liquid material for a period of time in relation to a user-defined flush speed. The Flush Enable feature can only be activated when the tractor is stopped.

To Activate Flush Enable:

1. Change Flush Disable to Enable. Flush Enable must be activated before the Flush Ground Speed feature displays on the Ground Speed Setup screen.
2. A Flush Ground Speed greater than 0 must be entered on the Ground Speed setup screen for this feature to operate.



VALVE CALIBRATION - PLANTER CONTROL

The **Valve Calibration** screen sets the machine hydraulic system parameters and should be performed for best results. Each control channel that is enabled requires a valve calibration.

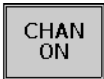
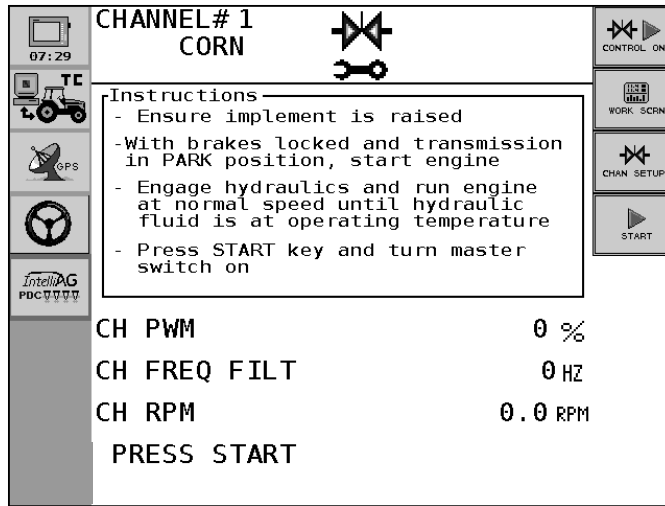
At the Channel Setup screen, press the **Valve Calibration** button to access the Valve Calibration screen.



NOTE: Verify disc speed high limit is set correctly. Valve calibration will try and obtain the high disc speed.

Figure 40

Valve Calibration Screen - Planter Control



CHANNEL ON

The **Channel On** button appears on this screen only if the channel is turned off. The channel must be ON before performing a valve calibration. Press the **Channel On** button to turn the channel on.

WARNING

When the **START** key is engaged, the machine will become operational. All necessary precautions must be taken to ensure user safety. Failure to practice all necessary caution may result in serious injury or death.

CAUTION

Hoppers are assumed to be empty for this calibration. If they are loaded, material will be dispensed onto the ground.

To perform the Control Channel Valve Calibration:

1. Move the implement to the "raised" position.
2. Apply the tractor brakes and lock in the applied position.
3. Put the transmission in "park" or in a locked, neutral position.



4. Start the tractor and engage the hydraulic system, i.e. PTO or auxiliary lever.
5. Run the engine at normal operating speed until the hydraulic fluid is at normal operating temperature.
6. Press the **Start** button.
7. Turn the master switch to the ON position.
8. The valve calibration will immediately start.
9. Keep the hydraulics engaged until the calibration is complete. The calibration may take a minute up to several minutes. Each calibration step is monitored on the lower left corner of the display.
10. When the calibration is complete, the control shuts down automatically. All calibration data is automatically stored.

FILL DISK

NOTE: Top-level fill disk will run all active planter control and granular seeding control channels.

Fill Disk is used to fill the seed meters after a variety changes or after power up on air-actuated planters with seed to allow instant seed flow when the control is turned on. Pressing the **Fill Disk** button will rotate the seed meters 1 time, then stop.



FILL DISK FOR A CONTROL CHANNEL

1. Press the **Control Setup** button.
2. Press the **Channel Setup** button.
3. Press the **Fill Disk** button.
4. Raise the implement.
5. With brakes locked and transmission in the park position, start the engine.
6. Engage hydraulics and run engine at normal speed until hydraulic fluid is at operating temperature.

CAUTION

Implement will begin to operate after pressing the Start button. Ensure that all persons and objects are away from the implement to avoid personal injury.



7. Press the **Start** button. The seed meters will turn for 1 revolution, then stop.
8. Pressing the **Stop** button will also terminate the test.



Figure 41

Fill Disk Screen for One Control Channel





CONTINUOUS TEST

Continuous Test runs the control while stationary for troubleshooting or maintenance purposes. A remote test switch is recommended to perform this test.

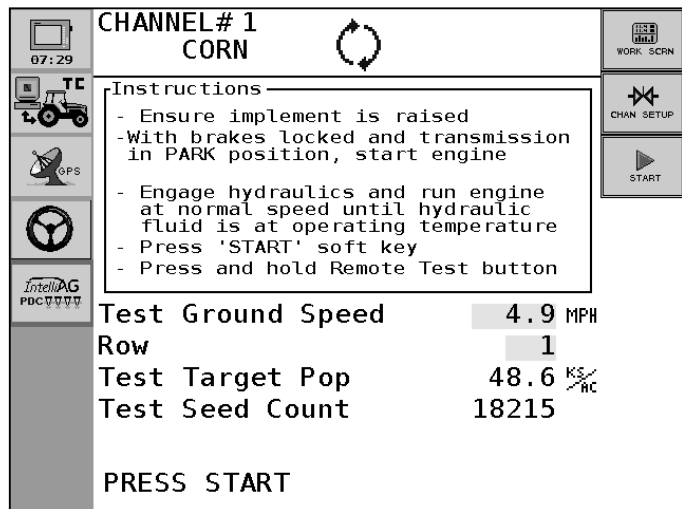


1. To access the Continuous Test screen, press the **Control Setup** button.
2. Press the **Channel Setup** button.
3. Press the **Continuous Test** button to display the Continuous Test screen.
4. The following parameters must be entered to perform a Continuous Test:
 - Test Ground Speed
 - Row

The values entered will not affect any other setup values that have previously been entered.

Figure 42

Continuous Test Screen



TEST GROUND SPEED

Test Ground Speed is the ground speed reference used to perform the test.

ROW

Row is the active row viewed on the system. The row that is set here is the row that reports back a seed count in the Test Seed Count value. The operator can change the row # to get performance of all rows during the Continuous Test to see row-to-row variability.

TEST TARGET POP

Test Target Pop is the seed rate at which the test is performed. This value is the current target rate and is automatically populated.



NOTE: *The Test Seed Count will automatically reset whenever a new Continuous Test is performed.*



TEST SEED COUNT

Test Seed Count is the seed count reported back on the specified row set in the row data item and is automatically populated.

To start the Continuous Test:

1. Press the **Start** button.
2. Press and hold remote test switch until the test is complete.
3. Release test switch and the control will stop.
4. Press the test switch again to clear the seed count and restart the control.
5. Steps 2-4 will repeat until the **Stop** button is pressed.

5 REV TEST

5 Rev Test checks the seed meters for accuracy. When started, the test will run the control for five revolutions of the seed meters then shut down. The seed count can then be correlated on a row versus the seed count actually dispensed by the meter. A remote test switch is recommended to perform this test.

To perform 5 Rev Test:

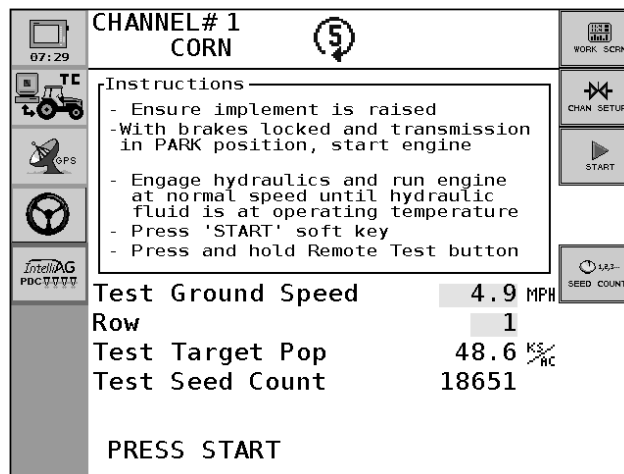
1. Press the **Control Setup** button.
2. Press the **Channel Setup** button.
3. Select the **5 Rev Test** button to access the **5 Rev Test** screen.
4. The following parameters must be entered to perform a 5 Rev Test.
 - Test Ground Speed
 - Row

The values entered do not affect any other setup values that have previously been tested.



Figure 43

5 Rev Test Screen





TEST GROUND SPEED

Test Ground Speed is the ground speed reference used to perform the test.

ROW

Row is the active row configured in the system. The row that is set here is the row that reports back a seed count in the Test Seed Count value. The operator can change the row # to get the seed count of all rows during the test.

TEST TARGET POP

Test Target Pop is the seed rate at which the test is performed. This value is the current target rate and is automatically populated.

TEST SEED COUNT

Test Seed Count is the seed count reported back on a specified row set in the row data item and is automatically populated.

To Start the Continuous Test:

1. Press the **Start** button.
2. The test will run for 5 revolutions then stop.

To display the number of seeds detected by each sensor, press the **Seed Count** button.

NOTE: Test Seed Count will automatically reset whenever a new Continuous Test is performed.



REMOTE TEST SWITCH

A momentary switch can be purchased from DICKEY-john that allows the the control to be turned on/off during the Continuous and 5 Rev tests.

The switch allows the operator to go back to the implement to perform the test and investigate mechanical issues or perform seed counts instead of performing the test inside the cab from the Virtual Terminal. The test switch will only function when the implement switch is in the up (off) position.

The remote test switch is to be connected to the actuator harness.

Remote test switch part number is 464210515S1.



CAUTION

Once testing is complete, the remote test switch should be disconnected to prevent accidental control engagement.



GRANULAR SEED AND GRANULAR FERT SETUP

The following constants on the Control Channel Setup screen define the parameters for Granular Seed and Granular Fertilizer.

Figure 44

Control Channel Setup-Granular Seed

09:10	CHANNEL# 1		WORK SCRIN
	Type	GRAN SEED CONTROL	
	Material Name	MATRL 1	
	Control Mode	Auto	
	Drive Type	PWM 1	
	Drive Freq.	100 HZ	
	Input Filter	50 %	
	Sensor Constant	360 PUL' /REV	
	Gear Ratio	1.000	
	# Seed Rows	0	
	Channel Width	360.0 IN	
	Flush Enable	Disabled	
	PreCharge(+)\Delay(-)	0.0 SEC	

Type

Select Granular Fertilizer or Granular Seeding as Control Type.

Material Name

The Material Name displays only when a material is configured for the same channel type.

Control Mode

AUTO-Control channel is calculating application rates based on ground speed and channel width under normal operating conditions.

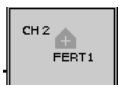
MANUAL W/FEEDBACK-Overrides the current system when not operating properly, i.e., faulty coil. Using the **Increment/Decrement** buttons from the Main Work screen sets the rate for the control channel. Manual Mode with Feedback shows the actual application rate being applied based on actual ground speed and constants.

MANUAL W/O FEEDBACK-Overrides the current system when not operating properly, i.e. bad feedback sensor. Using the **Increment/Decrement** buttons from the Main Operate screen sets the rate for the control channel. No application rate feedback will display.

Drive Type

PWM (Pulse Width Modulation)

A valve, usually hydraulic, which varies the oil flow to a hydraulic motor proportioned to electric current supplied. This type of valve consists of a flow cartridge and coil assembly.





NOTE: DICKEY-john Servo valves operate at 40 Hz; DICKEY-john Proportional Valves operate at 100 Hz.

NOTE: The correct number of pulses generated for one revolution must be determined for sensors other than DICKEY-john.

Servo

A hydraulic valve that is opened and closed by an electric motor gearbox.

Drive Frequency

Drive Frequency specifies the frequency for the proportional valve that is being used. The recommended setting for this option should be specified from the specific valve manufacturer.

Input Filter

The Input Filter provides a setting for the amount of filtering applied to the feedback frequency feedback of the control channel.

IMPORTANT: It is NOT recommended that the Input Filter be altered. Any adjustments could result in the channel not operating properly. If adjustments are made a valve calibration must be performed.

Sensor Constant

Sensor Constant establishes the number of pulses for one revolution of the metering unit. If a standard DICKEY-john application rate sensor is used, the value should be set to 360.0.

Gear Ratio

Gear Ratio specifies the actual ratio from the **application rate** sensor to the **output shaft**. This specifies the number of revolutions the application rate sensor turns in relation to one revolution the final output shaft turns.

Number (#) of Seed Rows

Allows entry of a specific number of seed rows to the control channel. Row assignment is given a priority based on the channel and will be assigned sequentially thereafter. Channel 1 will always be assigned to the first set of rows, channel 2 the next set of rows, and so on. This will disable the row alarms when a respective channel is turned off.

Channel Width

Granular Seeding

Channel Width requires a manual entry of the implement width for rows assigned to a specific channel.

Granular Fertilizer

Channel Width requires a manual entry of the fertilizer spread width.

Precharge Time

Precharge Time is a specified length of time a control channel will operate or be active with a minimum Precharge ground speed greater than 0. (Refer to the Ground Speed Setup section for Precharge Ground Speed Setup information). This feature will activate the control when the master switch is turned ON even without ground speed.



NOTE: *The master switch must be ON to activate the Precharge feature.*

The Precharge feature is typically used in applications that have significant distance between the implement row unit and storage bulk tank where seed placement takes several seconds due to the travel time of the seed/fertilizer from the bulk tank to the ground.

A Precharge alarm will display any time the Preset feature is established or changed and the master switch is turned ON.

IMPORTANT: A Precharge number MUST be entered as a positive number (5.0 seconds) for the system to identify between a Precharge or Delay Time state.

To activate Precharge:

1. At the Control Channel screen, enter a Precharge time. A Precharge Time must be entered before the Precharge Ground Speed feature displays on the Ground Speed Setup screen (Refer to Ground Speed Setup section).
2. Press the **Work Screen** button and select the **Speed Set** button.
3. Enter a Precharge Ground Speed greater than 0.



IMPORTANT: Turn the master switch ON to activate the Precharge feature.

Delay Time

NOTE: *Delay Time functionality may work differently than described above if the system has been purchased direct from the original equipment manufacturer. Refer to the manufacturer's operator manual for further instruction.*

IMPORTANT: A Delay Time number MUST be entered as a negative number (-5.0 seconds) for the system to identify between a Delay Time or Precharge state.

With an Implement Lift Switch

Delay Time determines the length of time before the control channel will start after the master switch has been turned ON and the implement switch is in a lowered position.

- The system will **immediately** shutdown the channel when the implement lift switch is in the raised position.
- The system will delay the channel shutdown if the master switch is turned OFF and the implement is in the down position.

Without an Implement Lift Switch

When the Delay Time feature is utilized without an implement lift switch:

- The control channel delays after the master switch has been turned ON.
- A delay also occurs and then shutdowns the control channel when the master switch is turned OFF.



Flush Enable

Flush Enable is a manual override mode that opens the valve and dispenses granular fertilizer, granular seed, or liquid material for a period of time in relation to a user-defined flush speed. The Flush Enable feature can only be activated when the tractor is stopped.

To activate Flush Enable:

1. Change Flush Disable to Enable. Flush Enable must be activated before the Flush Ground Speed feature displays on the Ground Speed Setup screen.
2. A Flush Ground Speed greater than 0 must be entered on the Ground Speed setup screen for this feature to operate.

VALVE CALIBRATION - GRAN SEED AND GRAN FERT

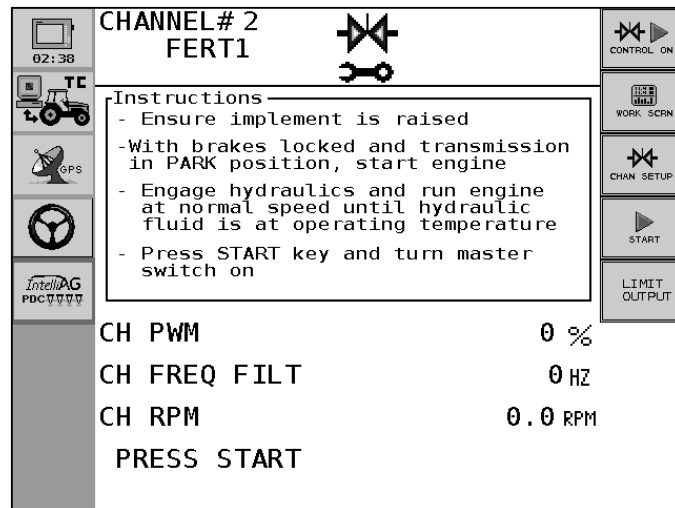


The **Valve Calibration** screen sets the machine hydraulic system parameters and should be performed for best results. Each control channel that is enabled requires a valve calibration.

Press the **Valve Calibration** button to access the Valve Calibration screen.

Figure 45

Control Channel Calibration Screen - Gran Seed and Gran Fert



CHANNEL ON

The **Channel On** button appears on this screen only if the channel is turned off. The channel must be ON before performing a valve calibration. Press the **Channel On** button to turn the channel on.



⚠ WARNING

When the **START** key is engaged, the machine will become operational. All necessary precautions must be taken to ensure user safety. Failure to practice all necessary caution may result in serious injury or death.

⚠ CAUTION

Hoppers are assumed to be empty for this calibration. If they are loaded, material will be dispensed onto the ground.



To perform the Control Channel Valve Calibration:

1. Move the implement to the “raised” position.
2. Apply the tractor brakes and lock in the applied position.
3. Put the transmission in “park” or in a locked, neutral position.
4. Start the tractor and engage the hydraulic system, i.e. PTO or auxiliary lever.
5. Run the engine at normal operating speed until the hydraulic fluid is at normal operating temperature.
6. Press the **Start** button.
7. Turn the master switch to the ON position.
8. The valve calibration will immediately start.
9. Keep the hydraulics engaged until the calibration is complete. The calibration may take a minute up to several minutes. Each calibration step is monitored on the lower left corner of the display.
10. When the calibration is complete, the control shuts down automatically. All calibration data is automatically stored.

FILL DISK

NOTE: Top-level fill disk will run all active planter control and granular seeding control channels.

Fill Disk is used to fill the seed meters after a variety change or after power up on air-actuated planters with seed to allow instant seed flow when the control is turned on. Pressing the **Fill Disk** button will rotate the seed meters one time, then stop.



FILL DISK FOR A CONTROL CHANNEL

1. Press the **Control Setup** button.
2. Press the **Channel Setup** button.
3. Press the **Fill Disk** button.
4. Raise the implement.
5. With brakes locked and transmission in the park position, start the engine.
6. Engage hydraulics and run engine at normal speed until hydraulic fluid is at operating temperature.



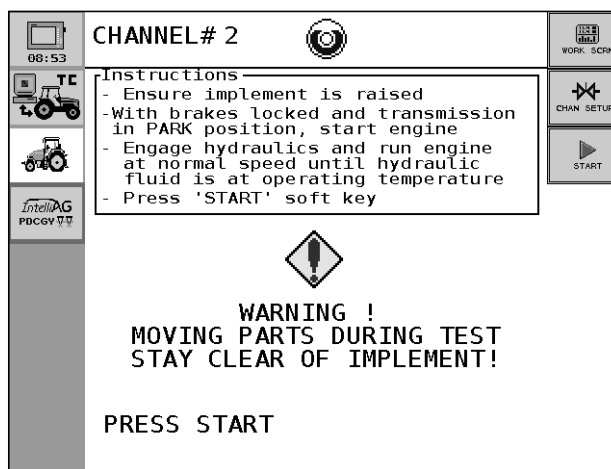
CAUTION

Implement will begin to operate after pressing the Start button. Ensure that all persons and objects are away from the implement to avoid personal injury.

7. Press the **Start** button. The seed meters will turn for one revolution, then stop.
8. Press the **Stop** button to terminate test.

Figure 46

Fill Disk for a Granular Seeding Channel





LIMIT OUTPUT

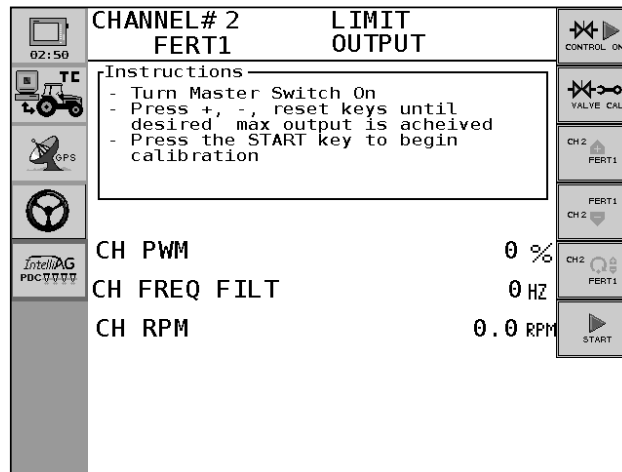
In certain instances, it is necessary to limit the output of the control channel. System capacities are greater than the actual desired capacities. These features allow setting the maximum output of the channel to prevent machine damage.

Press the **Limit Output** button to access the **Limit Output** screen.

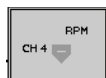


Figure 47

Limit Output Screen



NOTE: If the Channel is turned OFF, the Increment, Decrement, and Reset buttons will not function. Return to the Main Work screen to turn ON.



To Limit Max Output:

1. Move the implement to the "raised" position.
2. Apply the tractor brakes and lock in the applied position.
3. Put the transmission in "park" or in a locked, neutral position.
4. Start the tractor and engage the hydraulic system, i.e. PTO or auxiliary lever.
5. Run the engine at normal operating speed until the hydraulic fluid is at normal operating temperature.
6. Place the master switch in the ON position.
7. To change the valve position, press the **Increment** or **Decrement** buttons repeatedly until the desired minimum or maximum output value is reached.
8. Press the **Start** button and the valve calibration will immediately begin. The calibration will run using the new max flow value.



SPREADER CALIBRATION- GRAN SEED AND GRAN FERTILIZER

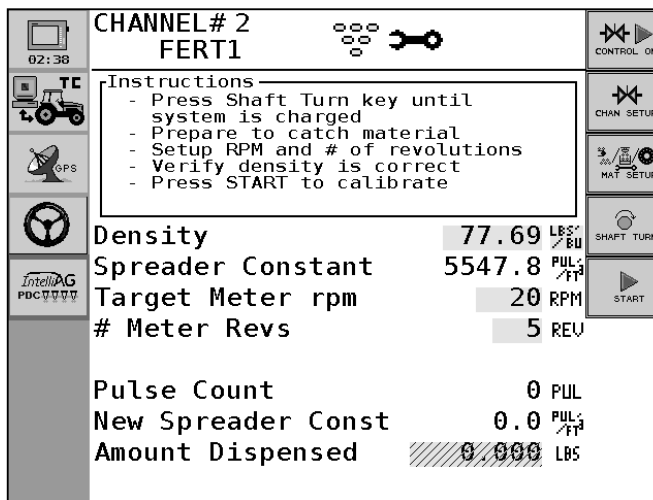


The Spreader Constant Calibration screen performs a catch test to determine the spreader constant. This button is only available for granular seed and fertilizer applications.

Press the **Spreader Calibration** button to access the **Spreader Calibration** screen.

Figure 48

Spreader Constant Calibration Screen



⚠ WARNING

When the START key is engaged, the machine will become operational. All necessary precautions must be taken to ensure user safety. Failure to practice all necessary caution may result in serious injury or death.

⚠ CAUTION

Hoppers must contain material. Be prepared to catch the material in a container so it can be weighed at the end of the calibration.

DENSITY

Relative granular density as represented by the weight of product per volume (Lbs/ft³, Lbs/bu). If not known, enter a value of 1 Lbs/ft³.

SPREADER CONSTANT

Determines how many pulses the application rate sensor produces per volume of material discharged.



NOTE: *If performing a Spreader Calibration on a box type drill, catch the output of a few seed meters, average the weight measured from these meters, and multiply this average weight by the total number of meters on the drill. Enter this weight for the Amount Dispensed value.*



TARGET METER RPM

Target Meter RPM is the speed at which the output meter shaft turns while the calibration is performed.

NUMBER (#) METER REVS

Number of Meter Revolutions is the number of revolutions the meter will turn during the calibration. This will constitute the length of the test. The higher the number, the more accurate the calibration.

To perform the Spreader Constant Calibration:

1. Ensure that the system has performed a valve calibration.
2. Move the implement to the "raised" position.
3. Apply the tractor brakes and lock in the applied position.
4. Put the transmission in "park" or in a locked, neutral position.
5. Start the tractor and engage the hydraulic system, i.e. PTO or auxiliary lever.
6. Run the engine at normal operating speed until the hydraulic fluid is at normal operating temperature.
7. Perform a fill disk until seeds are continuously being dispensed.
8. Place a container to catch the dispensed material.
9. Press the **Start** button.
10. Turn the master switch to the ON position.
11. The control will run the dispensing unit (meter/conveyor) at the specified RPM for the specified number of meter revolutions and then shut down automatically.
12. Weigh the material dispensed and enter the value into the Amount Dispensed field.
13. The new spreader constant value will automatically calculate.

PULSE COUNT

A pulse count produced from the feedback sensor. This number is informational only.



NEW SPREADER CONSTANT

After the spreader calibration is performed and the amount is entered, press the **Save** button to accept the new constant.

AMOUNT DISPENSED

Enter the amount (Lbs/Kg) dispensed after performing the spreader constant calibration. The amount dispensed number is used with pulse count and density to calculate the new spreader constant.



SHAFT TURN

The **Shaft Turn** button turns the shaft one (1) gear revolution and fills the seed meter for instant seed flow when the control is turned on.

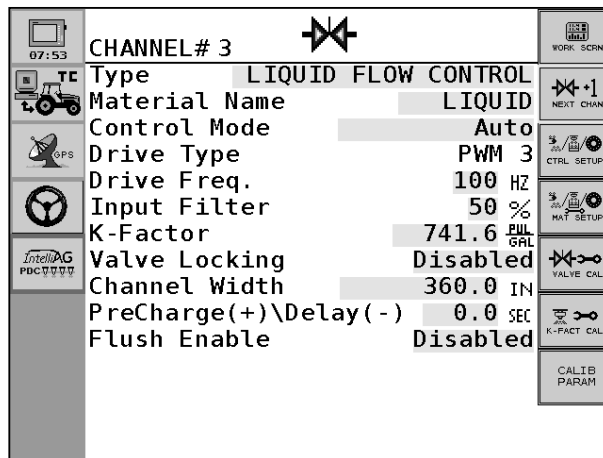


LIQUID FLOW SETUP

The following constants on the Control Channel Setup screen define the parameters for Liquid Flow Control.

Figure 49

Control Channel Setup-Liquid Flow Control Setup Example



Type

Select Liquid Flow as the channel type.

Material Name

The Material Name displays only when a material is configured for the same channel.

Control Mode

AUTO-Control Channel is calculating application rates based on ground speed and channel width under normal operating conditions.

MANUAL W/FEEDBACK-Overrides the current system when not operating properly, i.e., faulty coil on hydraulic valve. Using the **Increment/Decrement** buttons from the Main Work screen will set the rate for the control channel. Manual Mode with Feedback will show the actual application rate being applied based on actual ground speed and constants.

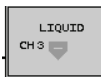
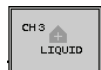
MANUAL W/O FEEDBACK-Overrides the current system when not operating properly, i.e., bad flow meter. Using the **Increment/Decrement** buttons from the Main Work screen will set the rate for the control channel. No application rate feedback will display.

Drive Type

Three drive type selections are available based on the following:

SERVO

A ball valve or butterfly valve that is driven by an electric motor gearbox and the valve is installed in the main product delivery line.





NOTE: DICKY-john Servo valves operate at 40 Hz; DICKY-john Proportional valves operate at 100 Hz.

SERVO RETURN

A ball valve or butterfly valve that is driven by an electric motor gearbox and the valve is installed in the tank return line.

PWM (Pulse Width Modulation)

A proportional valve regulating hydraulics and varies the oil flow to a hydraulic motor proportioned to electric current supplied. This type of valve consists of a flow cartridge and coil assembly.

Drive Frequency

Drive Frequency specifies the frequency for the proportional or servo valve that is being used. The recommended setting for this option should be specified from the specific valve manufacturer.

Input Filter

The Input Filter provides a setting for the amount of filtering applied to the flow meter feedback frequency of the control channel.

IMPORTANT: It is NOT recommended that the Input Filter be altered. Any adjustments could result in the channel not operating properly. If adjustments are made, a valve calibration must be performed.

K Factor

K Factor specifies how many pulses are produced by the sensor per gallon/liter of liquid through the flow meter. A flow meter calibration is recommended for better accuracy. However, if known, the K-Factor can be entered manually. If not, a flow meter calibration is required. Refer to the Liquid Flow Calibration section for additional information.

Valve Locking

When enabled, locks the valve into the last operating position whenever the booms are turned off. This maintains system pressure while turning so a quick spray pattern may resume after turning is complete. Valve locking is also used for tank agitation.

Channel Width

Channel Width requires a manual entry of the width of the liquid sprayed.

Precharge Time

Precharge Time is a specified length of time a control channel will operate or be active with a minimum Precharge ground speed greater than 1. (Refer to the Ground Speed Setup section for Precharge Ground Speed setup information).

IMPORTANT: A Precharge number MUST be entered as a positive number (5.0 seconds) for the system to identify between a Precharge or Delay Time state.



NOTE: The master switch must be ON to activate the Precharge feature.

NOTE: Delay Time functionality may work differently than described above if the system has been purchased direct from the original equipment manufacturer. Refer to the manufacturer's operator manual for further instruction.

To activate Precharge:

1. At the Control Channel screen, enter a Precharge time. A Precharge Time must be entered before the Precharge Ground Speed feature displays on the Ground Speed Setup screen (Refer to Ground Speed Setup section).
2. Press the **Work Screen** button and select the **Speed Set** button.
3. Enter a Precharge Ground Speed greater than 0.

IMPORTANT: Turn the master switch ON to activate the Precharge feature.

Delay Time

IMPORTANT: A Delay Time number **MUST** be entered as a negative number (-5.0 seconds) for the system to identify between a Delay Time or Precharge state.

With an Implement Lift Switch

Delay Time determines the length of time before the control channel will start after the master switch has been turned ON and the implement switch is in a lowered position.

- The system will **immediately** shutdown the channel when the implement lift switch is in the raised position.
- The system will delay the channel shutdown if the master switch is turned OFF and the implement is in the down position.

Without an Implement Lift Switch

When the Delay Time feature is utilized without an implement lift switch:

- The control channel will delay after the master switch has been turned ON.
- A delay will also occur and then shutdown the control channel when the master switch is turned OFF.

Flush Enable

Flush Enable is a manual override mode that opens the valve and dispenses granular fertilizer, granular seed, or liquid material for a period of time in relation to a user-defined flush speed. The Flush Enable feature can only be activated when the tractor is stopped.

To activate Flush Enable:

1. Change Flush Disable to Enable. Flush Enable must be activated before the Flush Ground Speed feature displays on the Ground Speed Setup screen.
2. A Flush Ground Speed greater than 0 must be entered on the Ground Speed setup screen for this feature to operate.



VALVE CALIBRATION - LIQUID

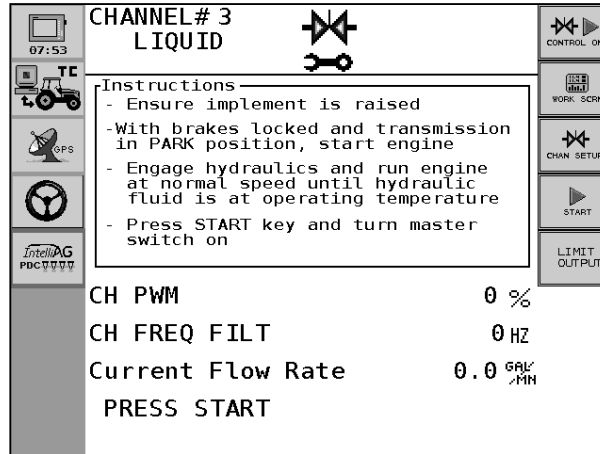


The **Valve Calibration** screen sets the machine hydraulic system parameters and should be performed for best results. Each control channel that is enabled requires a valve calibration.

Press the **Valve Calibration** button to access the Valve Calibration screen.

Figure 50

Control Channel Calibration Screen - Liquid Flow



CHANNEL ON

The **Channel On** button appears on this screen only if the channel is turned off. The channel must be ON before performing a valve calibration. Press the **Channel On** button to turn the channel on.

WARNING

When the **START** key is engaged, the machine will become operational. All necessary precautions must be taken to ensure user safety. Failure to practice all necessary caution may result in serious injury or death.

CAUTION

Hoppers should have material for this calibration and material will be dispense onto the ground when running the calibration.

To perform the Control Channel Valve Calibration:

1. Move the implement to the “raised” position.
2. Apply the tractor brakes and lock in the applied position.
3. Put the transmission in “park” or in a locked, neutral position.
4. Start the tractor and engage the hydraulic system.
5. Run the engine at normal operating speed until the hydraulic fluid is at normal operating temperature.
6. Press the **Start** button.





7. Turn the master switch to the ON position.
8. The valve calibration will immediately start.
9. Keep the hydraulics engaged until the calibration is complete. The calibration may take a minute up to several minutes. Each calibration step is monitored on the lower left corner of the display.
10. When the calibration is complete, the control shuts down automatically. All calibration data is automatically stored.

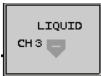
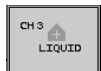
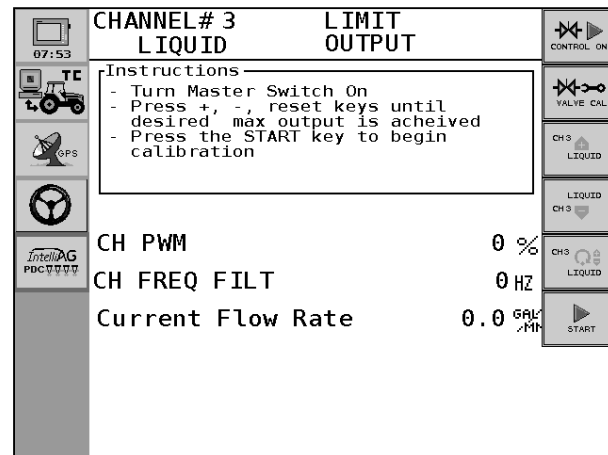
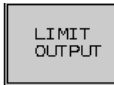
LIMIT OUTPUT

In certain instances, it is necessary to limit the output of the control channel. System capacities are greater than the actual desired capacities. These features allow setting the maximum output of the channel to prevent machine damage.

1. Press the **Limit Output** button to access the **Limit Output** screen.

Figure 51

Limit Output Screen



To Limit Max Output:

1. Move the implement to the "raised" position.
2. Apply the tractor brakes and lock in the applied position.
3. Put the transmission in "park" or in a locked, neutral position.
4. Start the tractor and engage the hydraulic system.
5. Run the engine at normal operating speed until the hydraulic fluid is at normal operating temperature.
6. Place the master switch in the ON position.
7. To change the valve position, press the **Increment** or **Decrement** buttons repeatedly until the desired minimum or maximum output value is reached.
8. Press the **Start** button and the valve calibration will immediately begin. The calibration will run using the new max flow value.

NOTE: If the channel is turned OFF, the Increment, Decrement, and Reset buttons will not function. Return to the Main Work screen to turn ON.





LIQUID FLOW CALIBRATION

To determine the actual K-Factor of a system, water should be dispensed through the system and measured. The calibration procedure will accumulate the pulse. At the end of the calibration procedure, the operator enters the amount dispensed. This number becomes the actual K-Factor instead of the one stamped on the flow meter body.

One of two methods can be used to measure the gallons of liquid flowing through the sprayer system. The more liquid passing through the system during calibration increases the degree of K-Factor accuracy.

Method 1 100% Catch Test:

This is the recommended method because a larger volume of liquid passes through the entire sprayer system making errors in weighing a smaller factor.

1. Fill the tank and weigh the load.
2. Activate the calibration routine.
3. After spraying a few hundred gallons but before the load is empty, stop the calibration.
4. Weigh the load again.
5. Calculate gallons dropped.

Method 2 Partial Catch:

1. Use a container such as a bucket or barrel to catch all liquid.
2. Weigh empty container.
3. Weigh container with liquid.
4. Calculate weight of the liquid (weight of full container minus empty container).
5. Calculate gallons dispensed.
6. Calculate % of total volume caught.
7. Gallons dropped/% caught.

Method 3 Nozzle Flow Meter Test:

1. Use measured catch container.
2. Set target flow rate.
3. Enter # of nozzles of complete channel.
4. Catch volume dispensed from nozzle in 1 minute.
5. Catch multiple nozzles.
6. Average the volume caught from the collected nozzles.
7. Enter average value.

INITIATING A LIQUID FLOW CALIBRATION PROCEDURE

1. From the **Channel Setup** screen, press the **K-Factor Calibration** button.
2. Set the Target Flow Rate and Target Ground Speed which will calculate the operation rate.
3. Press the **Start** button to initiate flow calibration procedure.
4. Press **Stop** when container is full.
5. Enter amount (gallons) dispensed in the **Total Amount Collect** field.
6. Press **Save** button to accept the selection.

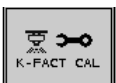
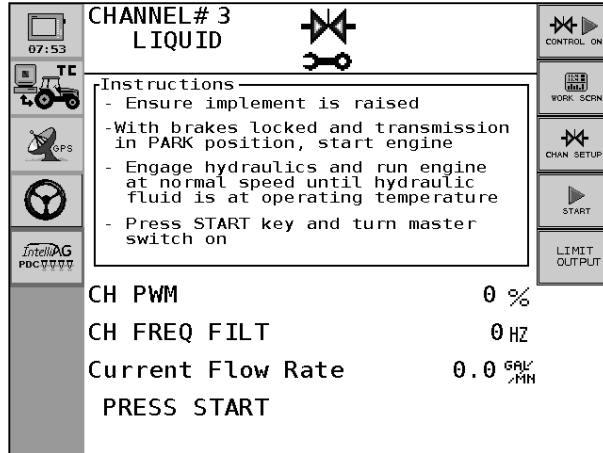




Figure 52

Liquid Flow Calibration Screen



WARNING

When the START key is engaged, the machine will become operational. All necessary precautions must be taken to ensure user safety. Failure to practice all necessary caution may result in serious injury or death.

CAUTION

Tanks must contain material. Be prepared to catch the material in a container so it can be weighed at the end of the calibration.



RPM CONTROL SETUP

The following constants on the Control Channel Setup screen define the parameters for RPM Control.

Figure 53

Control Channel Setup - RPM Control

07:54	CHANNEL# 4		WORK SCRN
	Type	RPM CONTROL	
	Material Name	RPM	NEXT CHAN
	Control Mode	Auto	
	Drive Type	PWM 4	CTRL. SETUP
	Drive Freq.	100 HZ	
	Input Filter	50 %	MAT SETUP
	Sensor Constant	360	
	Master Switch Off	Disabled	
	Ramp Up/Down	4.8 %	VALVE CAL
	Disable Control On	Disabled	
	Control Failure Alarm	Disabled	CALIB PARAM

TYPE

Determines the control channel type as RPM control.

MATERIAL NAME

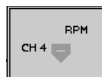
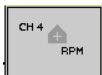
The Material Name displays only when a material is configured for the same channel type.

CONTROL MODE

AUTO-Control channel is calculating application rates based on ground speed and channel width under normal operating conditions.

MANUAL W/FEEDBACK-Overrides the current system when not operating properly, i.e., faulty coil. Using the **Increment/Decrement** buttons from the Main Operate screen will set the RPM for the control channel. Manual Mode with Feedback will show the actual RPM based on actual ground speed and constants.

MANUAL W/O FEEDBACK-Overrides the current system when not operating properly, i.e. bad feedback sensor. Using the **Increment/Decrement** buttons from the Main Work screen will set the RPM for the control channel. No application rate feedback will display.





DRIVE TYPE

PWM (Pulse Width Modulation)

A valve, usually hydraulic, which varies the oil flow to a hydraulic motor proportioned to electric current supplied. This type of valve consists of a flow cartridge and coil assembly.

Servo

A hydraulic valve that is opened and closed by an electric motor gearbox.

NOTE: DICKEY-john Servo Valves operate at 40 Hz; DICKEY-john Proportional Valves operate at 100 Hz.

DRIVE FREQUENCY

Drive Frequency specifies the frequency for the proportional valve that is being used. The recommended setting for this option should be specified from the specific valve manufacturer.

INPUT FILTER

The Input Filter provides a setting for the amount of filtering applied to the feedback frequency feedback of the control channel.

IMPORTANT: It is NOT recommended that the Input Filter be altered. Any adjustments could result in the channel not operating properly. If adjustments are made a valve calibration must be performed.

SENSOR CONSTANT

Sensor Constant establishes the number of pulses for one revolution of the metering unit. If a standard DICKEY-john application rate sensor is used, the value should be set to 360.0.

MASTER SWITCH OFF

Disabled-Shuts down the control channel when booms are turned off. Channel will start operating again when master switch is turned on.

Locked-Locks the valve into the last operating position when booms are turned off. This maintains system pressure while turning so a quick spray pattern may resume after turning is complete. Also used for tank agitation.

Active-Channel continues to operate after the master switch is turned off.

RAMP UP/DOWN

Sets the response time of the RPM control. The higher the value, the quicker the response; the lower the value, the slower the response time. Default value is set a 4.8%.

CAUTION

Use caution when selecting a ramp up/down value. A rate set too high may cause equipment damage.



DISABLE CONTROL ON CONTROL FAILURE ALARM

The setting for Disable Control on Control Failure Alarm shuts down ALL of the active control channels if the RPM sensor fails.

- ENABLED setting shuts down the control channels when the RPM sensor fails
- DISABLED setting disables the function. All non-RPM control channels continue to operate with a failed RPM sensor.



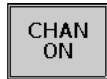
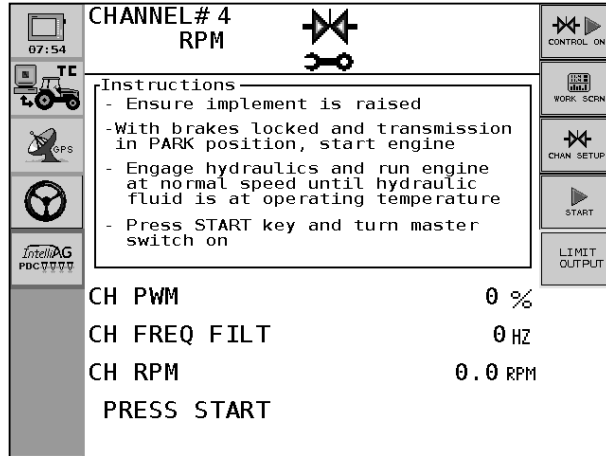
VALVE CALIBRATION - RPM CONTROL

The **Valve Calibration** screen sets the machine hydraulic system parameters and should be performed for best results. Each control channel that is enabled requires a valve calibration.

Press the **Valve Calibration** button to access the Valve Calibration screen.

Figure 54

Valve Calibration RPM Control



CHANNEL ON

The **Channel On** button appears on this screen only if the channel is turned off. The channel must be ON before performing a valve calibration. Press the **Channel On** button to turn the channel on.

WARNING

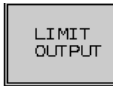
When the **START** key is engaged, the machine will become operational. All necessary precautions must be taken to ensure user safety. Failure to practice all necessary caution may result in serious injury or death.

CAUTION

Hoppers are assumed to be empty for this calibration. If they are loaded, material will be dispensed onto the ground.

To perform the Control Channel Valve Calibration:

1. Move the implement to the "raised" position.
2. Apply the tractor brakes and lock in the applied position.
3. Put the transmission in "park" or in a locked, neutral position.
4. Start the tractor and engage the hydraulic system.
5. Run the engine at normal operating speed until the hydraulic fluid is at normal operating temperature.



6. Press the **Start** button.
7. Turn the master switch to the ON position.
8. The valve calibration will immediately start.
9. Keep the hydraulics engaged until the calibration is complete. The calibration may take a minute up to several minutes. Each calibration step is monitored on the lower left corner of the display.
10. When the calibration is complete, the control shuts down automatically. All calibration data is automatically stored.

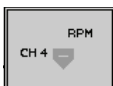
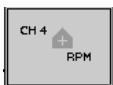
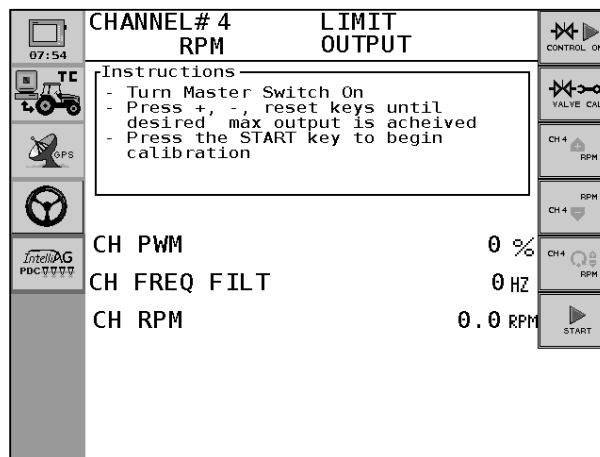
LIMIT OUTPUT

In certain instances, it is necessary to limit the output of the control channel. System capacities are greater than the actual desired capacities. These features allow setting the maximum output of the channel to prevent machine damage.

Press the **Limit Output** button to access the **Limit Output** screen.

NOTE: If the Channel is turned OFF, the Increment, Decrement, and Reset buttons will not function. Return to the Main Work screen to turn ON.

Figure 55
Limit Output RPM Control



To Limit Max Output:

1. Move the implement to the “raised” position.
2. Apply the tractor brakes and lock in the applied position.
3. Put the transmission in “park” or in a locked, neutral position.
4. Start the tractor and engage the hydraulic system.
5. Run the engine at normal operating speed until the hydraulic fluid is at normal operating temperature.
6. Place the master switch in the ON position.
7. To change the valve position, press the **Increment** or **Decrement** buttons repeatedly until the desired minimum or maximum output value is reached.
8. Press the **Start** button and the valve calibration will immediately begin. The calibration will run using the new max flow value.



MODULE CONFIGURATION

System components must be installed correctly and vehicle parameters entered into the IntelliAg system for effective operation. The following steps provide guidelines for entering those parameters.

IMPORTANT: Place the master switch in the OFF position to access and input data into the SETUP/CONFIGURATION mode.

If the current installation does not use a specific component (e.g., pressure sensors, hoppers, seed sensors) or if the module is not connected in the system, the module will not display on the screen.

The Module Configuration screen identifies modules on the CAN bus and the sensors connected to each module. This configuration is necessary for proper sensor monitoring and self-test operation. A check mark to the left of each module's Serial Number identifies that module as active and communicating module on the bus.

1. From the Main Work screen, press the **Module Configuration** button to access the Module Configuration screen.

A **Module Next Page** button will display if more than 12 modules are connected. Press the **Module Next Page** button to display additional modules.

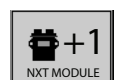


Figure 56

Module Configuration Screen

	SERIAL NUMBER	MODULE TYPE	MODULE ADDR.
✓	10003	WSMT-PDC	1
✓	10259	WSMB-18R	2

SERIAL NUMBER AND MODULE TYPE

Each module present on the CAN bus is identified by the serial number and module type. The module type corresponds to the identification on the serial number label attached to that module.



IMPORTANT: If an implement uses more than one module type, mount the modules on the implement in serial number order starting on the left side and proceeding to the right. Auto Sort will then sort the modules in the correct order for seed sensor assignment. Refer to the Auto Sort section for instruction.

MODULE ADDRESS

The Module Address column is a critical parameter used to identify module's position on the implement and to identify the number of rows connected to the Working Set Master (WSMT) and Working Set Members (WSMB) (optional). Accurate placement of the modules is required for correct console operation.

- Up to 16 seed sensors can connect to the Working Set Master
- Working Set Members can be added to monitor 18 rows each
- Up to 15 Working Set Members can be installed to monitor up to a total 214 rows

The following requirements must be observed when connecting seed sensors to the WSMT or WSMB:

1. Each Module Address is determined by the order in which the modules are installed on the implement.
2. The Module Address should always start at the number 1 position.
3. Seed sensors must be connected to the WSMT or WSMB continuously and consecutively. Any skipped rows will cause an alarm.

Example: Module Address 1 should be assigned to the module connected to Row 1. Module Address 2 should be assigned to the module connected to the next set of rows. The assigned numbering continues until all rows have been numbered.



AUTO SORT

At initial entry to the Module Configuration screen, the modules will appear in random order and may not correspond with the actual mounting location on the implement.

If modules are mounted on the implement by increasing serial number order from left to right, pressing the **Auto Sort** button will group same module types together and in the order the modules were mounted on the implement.

After Auto Sort is performed, modules will appear on the Module Configuration screen in groups by serial number order and module type.

IMPORTANT: The WSMT will always appear as Module Address 1 and may need to be repositioned to correspond to its actual mounting location after an Auto Sort.

To perform Auto Sort:

1. At the Module Configuration screen, press the **Auto Sort** button.
2. Verify that the module types and serial number have been sorted into groups.
3. Change the WSMT address number to the correct module address number as it relates to its mounting location on the implement. All other modules types should be in correct order if modules were installed as stated above.
4. Proceed to Auto Configuration.

AUTO CONFIGURATION

The **Auto Config** button is an automated method of configuring the attached seed sensors and hopper sensors. To utilize the Auto Configuration function, all sensors must be connected to the appropriate modules in correct sequence.

Auto Config detects the following:

- the presence of seed sensors, hopper, and pressure sensors connected to each module. The detected number of seed sensors for each module automatically appears in the # of Rows data items on the Seed Sensor Configuration screen.
- The detected number of hopper sensors are automatically entered in the # of Hopp data items on the Hopper Sensor Configuration screen.
- The detected number of pressure sensors are automatically entered in the # of ACC data items on the Accessory Sensors Configuration screen.
- Row #'s are automatically assigned based on the module address of each module.



1. Press the **Module Configuration** button to access the Module Configuration screen.
2. Press the **Auto Config** button. An hour glass appears in the upper right corner while the system is configuring.



IMPORTANT: Double check each sensor configuration to verify correct numbering. RPM sensors must be configured manually.

IMPORTANT: All sensors must be connected to the harnessing in the correct sequence for AUTO CONFIG to operate properly. Refer to the Installation Instructions accompanying each module for correct installation.

To run Auto Config:

1. Press the **Auto Config** button. An hourglass will appear in the upper right corner while the system is being configured.

AUTO SORT AND AUTO CONFIG EXAMPLES

Figure 57

Auto Sort Examples

Before Auto Sort

SERIAL NUMBER	MODULE TYPE	MODULE ADDR.
✓ 10245	WSMT - PDC	1
✓ 10038	WSMB - 18R	2
✓ 5000	POM	3
✓ 10037	WSMB - 18R	4
✓ 5001	POM	5
✓ 10036	WSMB - 18R	6

After Auto Sort

SERIAL NUMBER	MODULE TYPE	MODULE ADDR.
✓ 10245	WSMT - PDC	1
✓ 10036	WSMB - 18R	2
✓ 10037	WSMB - 18R	3
✓ 10038	WSMB - 18R	4
✓ 5000	POM	5
✓ 5001	POM	6

Move WSMT after Auto Sort

SERIAL NUMBER	MODULE TYPE	MODULE ADDR.
✓ 10036	WSMB - 18R	1
✓ 10245	WSMT - PDC	2
✓ 10037	WSMB - 18R	3
✓ 10038	WSMB - 18R	4
✓ 5000	POM	5
✓ 5001	POM	6

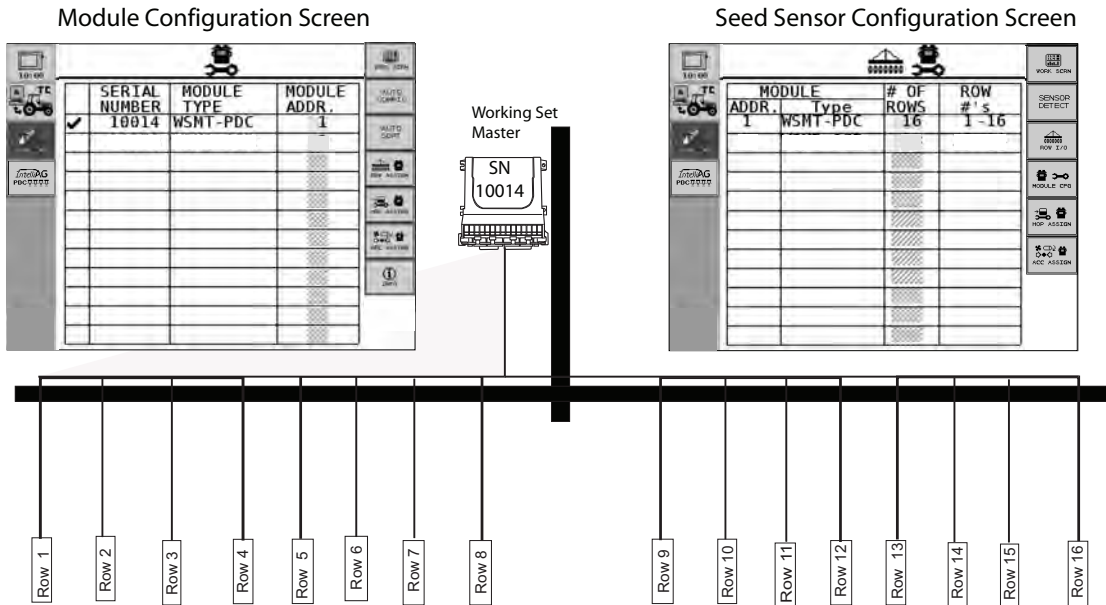


The following illustrations provide examples of possible installations:

Figure 58 depicts a 16 row installation connected to the Working Set Master and assigned to Module Address 1. No Working Set Member is utilized.

Figure 58

16 Row Installation Example (WSMT only)



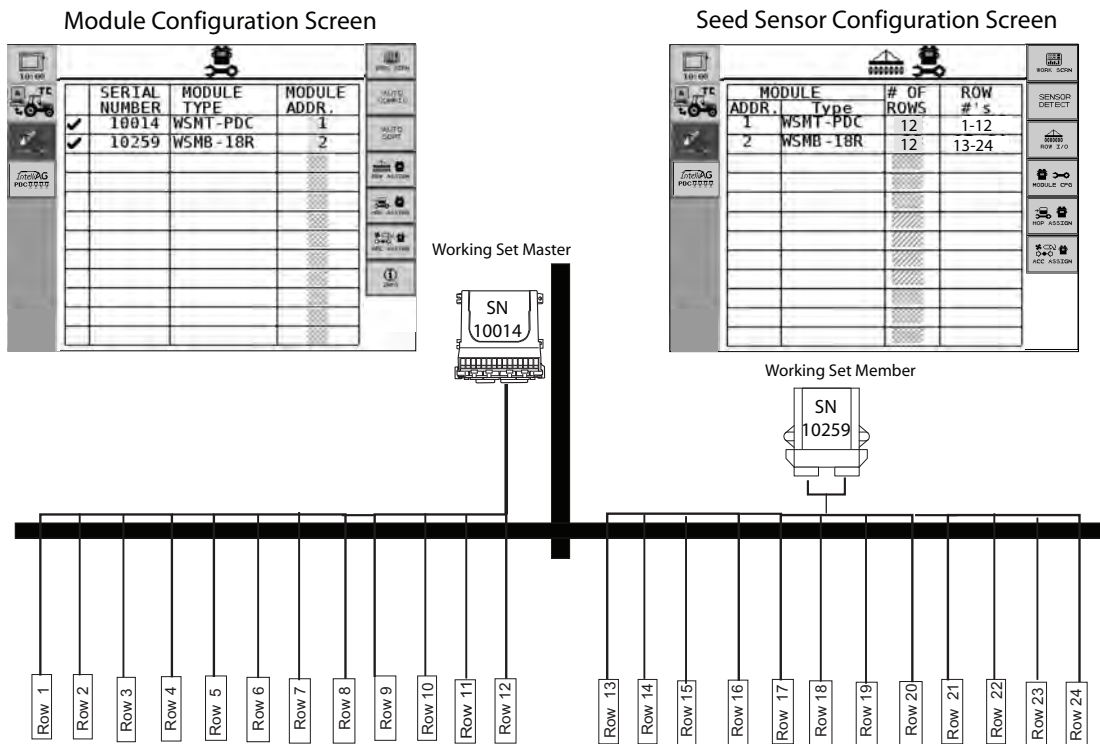
OPERATOR'S MANUAL



Figure 59 depicts a 24 row installation with the Working Set Master assigned to Module Address 1 to monitor rows 1-12. One Working Set Member is utilized to monitor rows 13-24.

Figure 59

24 Row Installation Example



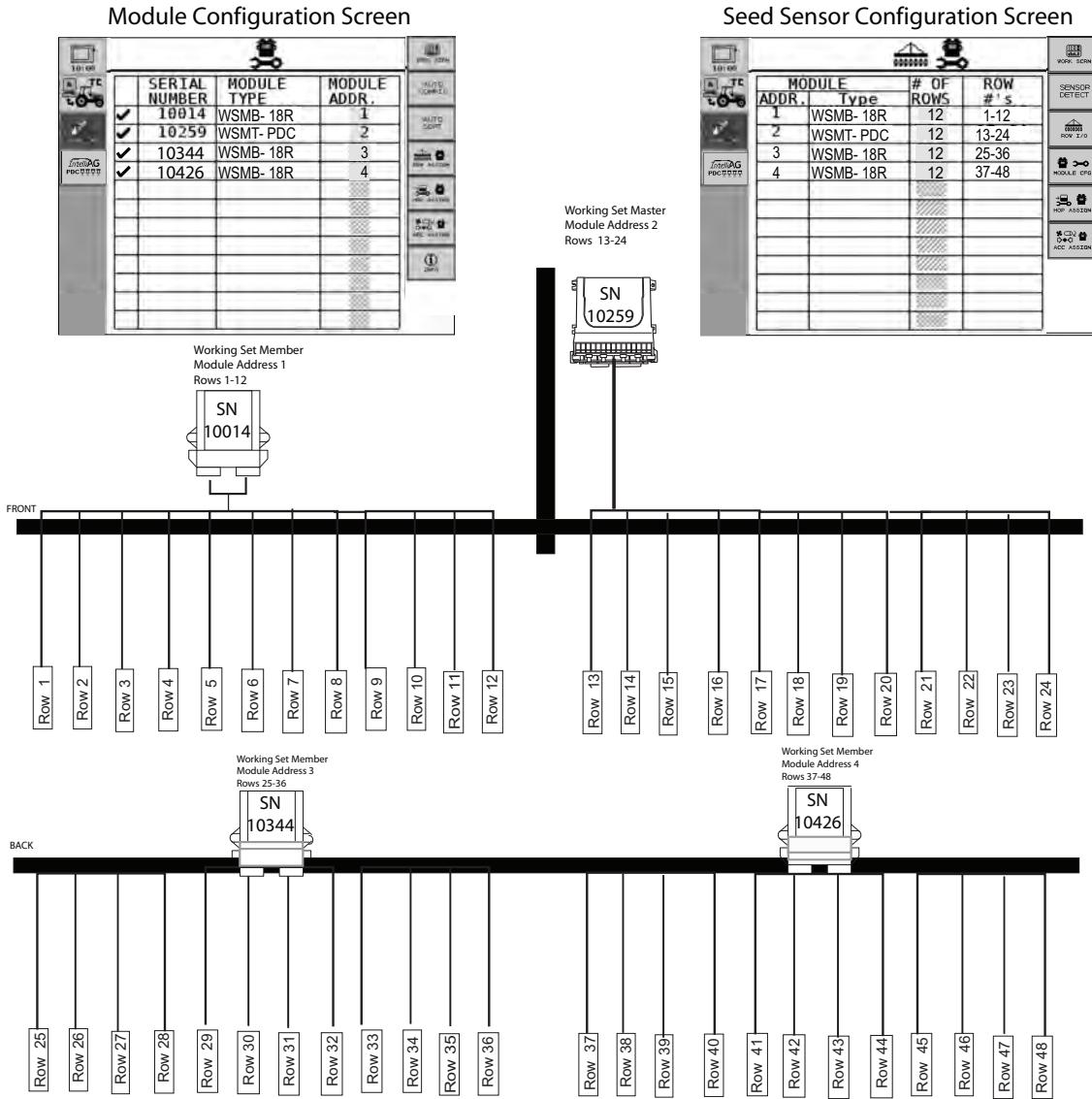
OPERATOR'S MANUAL



Figure 60 depicts a 48 row installation with the Working Set Master assigned to Module Address 2 and rows 13-24. Three Working Set Members are assigned to the additional rows.

Figure 60

48 Row Installation Example





ROW ASSIGNMENT

The **Row Assignment** screen automatically populates with the module address and module type entered at the Module Configuration screen.



1. Press the **Row Assignment** button to access the Row Assignment screen.

Figure 61

Row Assignment Screen

MODULE ADDR.	Type	# OF ROWS	ROW #'s
1	WSMT-PDC	16	1 - 16
2	WSMB-18R	18	17 - 34

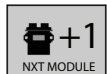
The following data items can be edited:

IMPORTANT: The # or Row data items for each listed module and the Row #'s value will automatically populate if the Auto Config button is used to configure installed sensors.

OF ROWS

The # of Rows column displays the total number of seed sensors that are connected to each module. The Row #'s value is automatically configured by Auto Config for proper row numbering for each module based upon the module address value and # of rows.

A **Module Next Page** button will display if more than 12 modules are connected. Press the **Module Next Page** button to display additional modules.



NOTE: Only modules that support seed sensors display on the **Row Assignment** screen.

To edit # Of Rows data:

1. Enter the number of rows to be assigned to each module.
2. Press the **Sensor Detect** button to detect and test seed sensors. An hour glass will appear in the upper right corner while the sensors are tested.





3. If the number of sensors detected on each module is not in agreement with the # of Rows value entered, an alarm will activate.
 - Verify that the # of sensors entered on the Row Assignment screen match the actual number of sensors connected to the appropriate module.
 - Confirm that all harnessing and sensors are connected properly.

Refer to the Troubleshooting section for further information.

ROW STATUS/ROW WIDTH SETUP

The **Row Setup** screen controls the rows that are monitored and the distance between rows and implement width.

Individual rows can be set to ON or OFF. Any detected row can be set to OFF. Rows set to OFF will remain OFF until they are turned ON again or are set to ON through the Pattern Select. Rows set to OFF are ignored by the system and will not report seed data or react to row failures.

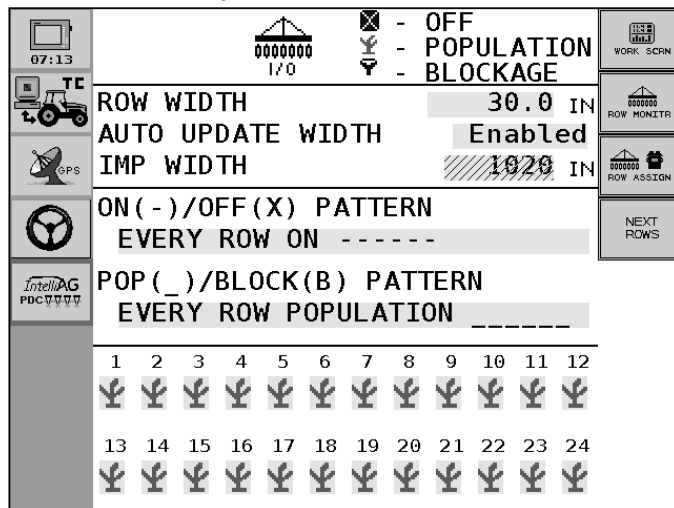
1. Press the **Row Setup** button to access the Row Status/Row Width Setup screen.



NOTE: The Next Rows button is only present if more than 24 rows are configured.

Figure 62

Row Status/Row Width Setup Screen



ROW WIDTH

Row Width is used for seed rate data and control calculations and is the distance in inches (centimeters) between rows with a resolution of 0.1. This value updates automatically with changes in the On/Off Pattern Setting option if the Auto Update Width option is set to Enabled.

AUTO UPDATE WIDTH

Auto Update Width automatically updates the Row Width and Implement Width settings when changes are made to the Pattern Setting option.



NOTE: Depending on the configured number of rows, some On/Off pattern settings can result in erroneous row width or implement width updates if the Auto Update Width is enabled. Always check the calculated values for accuracy when the Auto Update Width is enabled. If the adjusted values are not correct, disable the Auto Update Width feature and manually enter a row width and implement width.

There are two choices available for this option:

ENABLED

Row Width and Implement Width settings automatically adjust with ON/OFF pattern setting changes.

The following two examples use a 16 row planter set for 15.0 inch row width. Implement width is automatically calculated as 240.0 inches.

Example 1: The On/Off Pattern Setting is changed to every other row (even rows) OFF. The row width parameter adjusts to 30.0 automatically. The implement width calculated value remains unaffected at 240.0 inches.

Example 2: The On/Off Pattern Setting is changed to every 3rd row off. The row width parameter adjusts to 22.5 inches automatically. The implement width value adjusts to 247.5 inches to accommodate the new pattern.

DISABLED

The Row Width and Implement Width values will not be adjusted with changes to the ON/OFF Pattern Setting. Implement Width will not be automatically calculated and must be manually entered.

IMP WIDTH

Implement Width is the seeding width of the implement in inches (centimeters) with a resolution of 0.1. This value is used for Total, Field 1/ Field 2 area accumulators only and does not affect seed rate data. Implement width automatically calculates as described in Auto Update Width if the feature is enabled. If Auto Update Width is disabled, manually enter the implement width.

ON/OFF PATTERN

For split, twin, or skip row type seeding implements there are 21 predefined patterns to configure row patterns. When a row pattern is selected, all of the rows are automatically turned ON or OFF according to the pattern. Individual rows in the Row Setup screen can still be manually edited to Population, Blockage, or Off before or after a pattern is selected. The pattern setting, when selected, will override previous individual existing row settings.



ON/OFF Pattern Symbols

Rows turned ON =

Rows turned OFF = X

Figure 63

Pre-Defined On/Off Patterns

PATTERN	Description/Example
... ..	Every Row On
-X -X -X	Every 2nd Row Off
X -X -X -	Every 2nd Row On
--X --X --X	Every 3rd Row Off
-X --X --X -	Every 3rd Row Off
X --X --X --	Every 3rd Row Off
XX -XX -XX -	Every 3rd Row On
X -XX -XX -X	Every 3rd Row On
-XX -XX -XX	Every 3rd Row On
---X ---X	Every 4th Row Off
--X ---X -	Every 4th Row Off
-X ---X --	Every 4th Row Off
X ---X ---	Every 4th Row Off
XXX -XXX -	Every 4th Row On
XX -XXX -X	Every 4th Row On
X -XXX -XX	Every 4th Row On
-XXX -XXX	Every 4th Row On
--XX --XX --XX	Twin Rows
-XX --XX --XX -	Twin Rows
XX --XX --XX --	Twin Rows
X --XX --XX --X	Twin Rows

BLOCKAGE PATTERN

Blockage Pattern determines which sensors are used to calculate population and those used only for blockage detection. Depending on the customer's preference at the time of purchase, either all Hi Rate sensors, all Recon Flow sensors, or a combination of the two can be chosen.

The system can be configured for:

- Every Row Population (_ _ _ _)
Using all Hi Rate sensors
- Every Row Blockage (BBBBBB)
Using all Recon Flow sensors
- Every 2nd Row Block (_B_B_B_)
Even rows use Recon and odd rows use Hi Rate
- Every 2nd Row Pop (B_B_B_)
Even rows use Hi Rate and odd rows use Recon

Row Icons

Population =

Blockage =

OFF = X

Pattern Definitions

Blockage = B

Population = -



HOPPER ASSIGNMENT

The **Hopper Assignment** screen displays:

- Module address
- Type
- Number of hoppers
- Hopper numbers for the system



To Assign Hoppers:

1. At the Module Configuration screen, press the **Hopper Assignment** button to access the Hopper Assignment screen.

Figure 64

Hopper Assignment Screen

MODULE		# OF	HOPP
ADDR.	Type	HOPP	# 's
1	WSMT-PDC	1	1 - 1

The following data items can be edited:

IMPORTANT: The # of Hopp data items for each listed module and the Hopp #'s value automatically populates if Auto Config is used to configure the installed sensors.

OF HOPPERS

NOTE: Only modules that support hopper sensors display on the **Hopper Assignment** screen.

The # of Hopp column displays the total number of hopper sensors that are connected to each module. The HOPP #'s value is automatically configured for proper numbering sequence for each module based upon the module address value when an Auto Config is performed.



To Edit # of Hoppers:

1. Enter the number of hoppers assigned for each module.
2. Press the **Sensor Detect** button to detect and test the hopper sensors. An hour glass appears in the upper right corner during system configuration.
3. If the number of sensors detected on each module is not in agreement with the # of Hopper values entered, an alarm activates.
 - Verify that the # of sensors entered on the Hopper Assignment screen matches the actual number of sensors connected.
 - Confirm that all hopper sensor harnessing is connected properly.

Refer to the Troubleshooting section for further information.

HOPPER SET

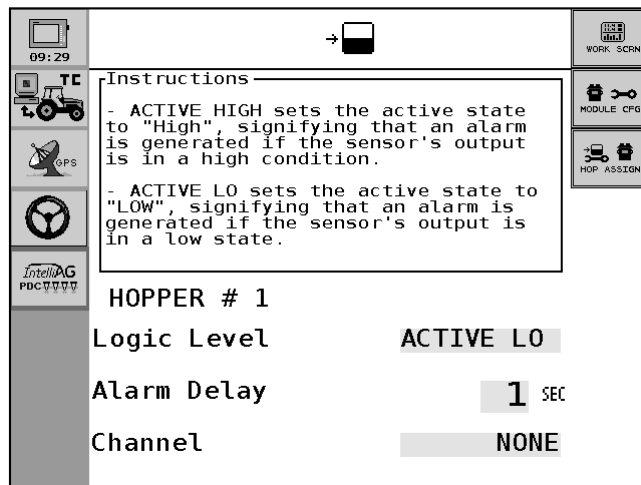


The **Hopper Set** screen controls the active state of the hopper sensor as well as the alarm delay time.

1. Press the **Hopper Set** button to access the Hopper Set screen.

Figure 65

Hopper Set Screen



LOGIC LEVEL

Logic Level sets the active state of the sensor and allows flexibility to connect sensors that have different active outputs. There are two settings available:

NOTE: For a Dj Hopper Level sensor, this value should be set to ACTIVE LO.

ACTIVE HIGH

- Sets the active state to "High" signifying that an alarm is generated if the sensor's output is in a high state. Use this setting if the connected sensor outputs a high condition when active.



ACTIVE LO

- Sets the active state to “Low” signifying that an alarm is generated if the sensor’s output is in a low state. Use this setting if the connected sensor outputs a low condition when active.

ALARM DELAY

Alarm Delay controls the delay time between the detection of a hopper alarm condition and the generation of the resulting alarm. The value is entered in seconds.

CHANNEL

Assigns the hopper sensor to a specific control channel.

ACCESSORY ASSIGNMENT

The Accessory Assignment screen configures optional sensors such as an RPM to monitor shaft/fan or an air pressure sensor.

The **Accessory Assignment** screen displays:

- Module address
- Type
- Number of accessories
- Accessory numbers for the system

1. At the Module Configuration screen, press the **Accessory Assignment** button to access the Accessory Assignment screen.

Figure 66

Accessory Assignment Screen

MODULE ADDR.	Type	# OF PRES	PRES #'s
1	WSMT-PDC	1	1 -1

	Type	# OF RPMS	RPM #'s
1	WSMT-PDC		

IMPORTANT: Auto Config detects the presence of a pressure sensor and automatically configures and populates into the Accessory Assignment screen. An RPM sensor must be configured manually.



OF PRESSURE/RPM SENSORS

The Number (#) of Pressure/RPM column displays the total number of RPM or pressure sensors that are connected to each module. When a pressure or RPM Sensor is entered into this column, the proper sensor numbering sequence for each module is automatically entered into the Pressure/RPM #'s column based upon the module address value.

RPM SETUP

The **RPM Setup** screen controls the parameters for each RPM sensor:

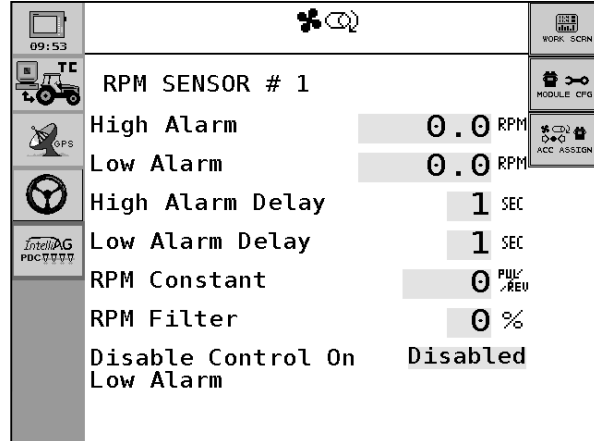
- High alarm
- Low alarm
- High alarm delay
- Low alarm delay
- RPM constant
- RPM filter
- Disable control on low alarm

When an RPM sensor is entered at the Accessory Assignment screen, an **RPM Setup** button displays.

1. Press the **RPM Setup** button to access the RPM Setup screen.

Figure 67

RPM Setup Screen



IMPORTANT: RPM sensors must be configured manually.

NOTE: Only modules that can support accessory sensors are displayed on the Accessory Assignment screen.

HIGH ALARM

The High Alarm option sets the RPM value at which a high RPM warning error is generated. The value is entered in RPM.

LOW ALARM

The Low Alarm option sets the RPM value at which a low RPM warning error is generated. The value is entered in RPM.



HIGH ALARM DELAY

The High Alarm Delay establishes the delay between the detection of a high RPM alarm condition and the resulting alarm display. The value is entered in seconds.

LOW ALARM DELAY

The Low Alarm Delay establishes the delay between the detection of a low RPM alarm condition and the resulting alarm display. The value is entered in seconds.

RPM CONSTANT

The RPM Constant is the number of pulses per shaft revolution. If the sensor is mounted directly to the shaft, the value will be the number of pulses generated by the sensor per revolution of the shaft itself. If the sensor is mounted elsewhere, a gear or sprocket ratio must be calculated and entered into the RPM constant.

RPM FILTER

The RPM filter value is used to filter the signal out of the RPM sensor. Typically no filtering is required so the standard value is set at 0%. If the RPM readout on the Main Work screen is oscillating in excess of 10%, increasing the filter value will filter the signal to reduce the oscillation. For a true RPM value this number should be set to 0%.

DISABLE CONTROL ON LOW ALARM

The setting for Disable Control on Low Alarm shuts down ALL active control channels if the RPM value of the selected sensor falls below the low alarm level setting.

The two settings include:

- **ENABLED** allows the control channels to be shut down when the RPM value falls below the low warning setting.
- **DISABLED** will disable the function. The control channels continue to operate normally regardless of the RPM value. However, when the low RPM state occurs, the information alarm still occurs.



PRESSURE SENSOR SETUP

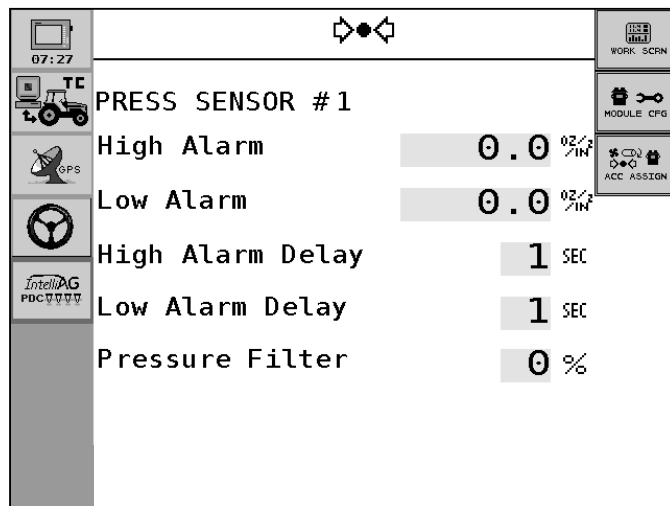
The **Pressure Sensor Setup** screen controls the parameters for each pressure sensor:

- High alarm
- Low alarm
- High alarm delay
- Low alarm delay
- Pressure filter

1. Press the **Pressure Setup** button to access the **Pressure Setup** screen.

Figure 68

Pressure Setup Screen



NOTE: The Auto Config button will detect the presence of a pressure sensor and automatically configures and populates into the Accessory Assignment screen.

HIGH ALARM

The High Alarm option sets the pressure value at which a high pressure warning error is generated. The value is entered in seconds.

LOW ALARM

The Low Alarm option sets the pressure value at which a low pressure warning error is generated. The value is entered in seconds.

HIGH ALARM DELAY

The High Alarm Delay establishes the delay between the detection of a high pressure alarm condition and the resulting alarm display. The value is entered in seconds.

LOW ALARM DELAY

The Low Alarm Delay establishes the delay between the detection of a low pressure alarm condition and the resulting alarm display. The value is entered in seconds.



PRESSURE FILTER

The Pressure Filter value filters the signal out of the pressure sensor. Typically no filtering is required and therefore the standard value is set at 0%. If the pressure readout on the Main Operate screen is oscillating in excess of 10%, increasing the filter value filters the signal to reduce the oscillation. For a true pressure value this number should be set to 0%.



ROW MONITOR SETUP

The **Row Monitor Setup** screen controls the parameters for:

- Material Name - monitor only
- High alarm delay
- Low alarm delay
- Population adjustment
- Population filter
- Row fail rate

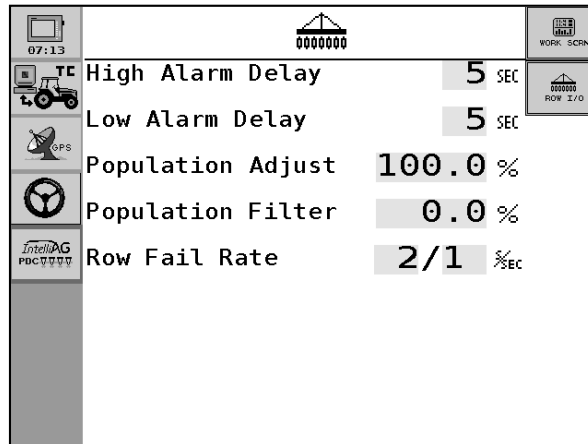


NOTE: A material name will display on the Row Monitor Setup screen only when ALL seeding control channels are disabled, no seed rows are assigned to channels, and material is set for Monitor Only.

1. From the Main Work screen, press the **Row Monitor Setup** button to access the Row Monitor Setup screen.

Figure 69

Row Monitor Setup Screen



IMPORTANT: For ground drive/nonhydraulic applications using the planter monitor only feature, all seeding control channels must be disabled, no seed rows assigned to these channels, and a Material Name selected at the Row Monitor Setup screen. Reference the Material Setup-Monitor Only section for additional information.

MATERIAL NAME

Material Name only displays if there are **NO** seeding channels enabled and no rows assigned to these channels. The Monitor Only selection must be selected at the Material Configuration Setup screen.

HIGH ALARM DELAY

The High Alarm Delay establishes the delay between the detection of a High Population Alarm condition and the resulting alarm display. The value is entered in seconds. If the value is set to 10, a row must be in a High Population Alarm condition continuously for 10 seconds before the alarm will be issued.

NOTE: Population is updated every 5 seconds. Setting the Alarm Delay for under 5 second intervals does not provide any delay at all.



LOW ALARM DELAY

The Low Alarm Delay establishes the delay between the detection of a Low Population Alarm condition and the resulting alarm display. The value is entered in seconds. If the value is set to 10, a row must be in a Low Population Alarm condition continuously for 10 seconds before the alarm will be issued.

POPULATION ADJUST

The Population Adjustment percentage scales the displayed population value to allow for inaccuracies with seed sensors in certain applications. This is a multiplier of the monitored population value. For true calculated results, the value should be set to 100.0%. If the monitored value is reading low, the value can be increased above 100.0% to achieve the desired population display. The displayed value is calculated by the monitored value x population scalar.

$$\frac{(\text{Actual Population} - \text{Monitor Population}) \times 100}{\text{Monitor Population}}$$

POPULATION FILTER

The Population Filter value is used to stabilize the monitored population display. For a true population value, this number should be set to 0.0%. 0.0 is no filtering at all. 99 is the highest level of filtering available. Set the filter to meet the appropriate level of filtering for your specific use.

ROW FAIL RATE

The Row Fail Rate value sets the threshold for Row Failure alarms. The value is entered in seeds per second. Both values are adjustable, allowing for numerous combinations. The default value is 2/1, which indicates a row failure threshold of 2 seeds in 1 second.



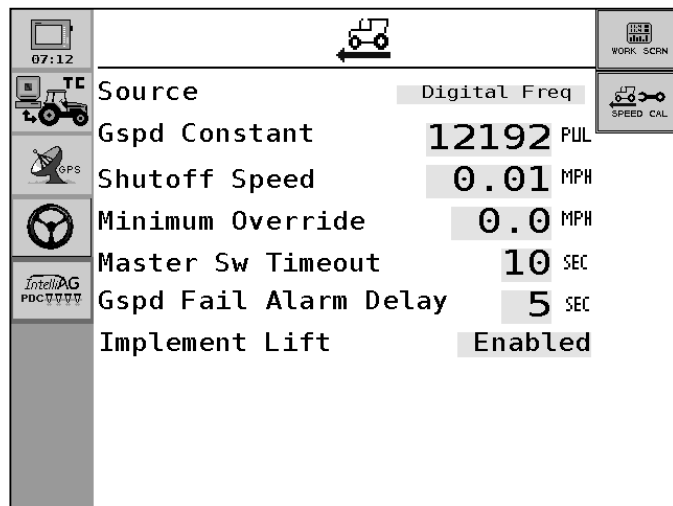
GROUND SPEED SETUP

Ground Speed Setup determines:

- The input source and type of ground speed sensor
- The manual default ground speed (only displays when manual is selected as source).
- Shut off speed
- Minimum override
- Ground speed constant
- Master switch timeout
- Ground speed fail alarm delay
- Implement Lift
- Precharge speed (displays only when the Precharge time is greater than 0 mph (0 kmh) on a Control Channel Setup screen)
- Flush ground speed (displays only when Flush Enable is activated on a Control Channel Setup Work screen, press the **Speed Set** button to access the Ground Speed Setup screen.

Figure 70

Speed Set Screen



SOURCE

Source selects the type of ground speed sensor used and where the sensor's input is on the system.

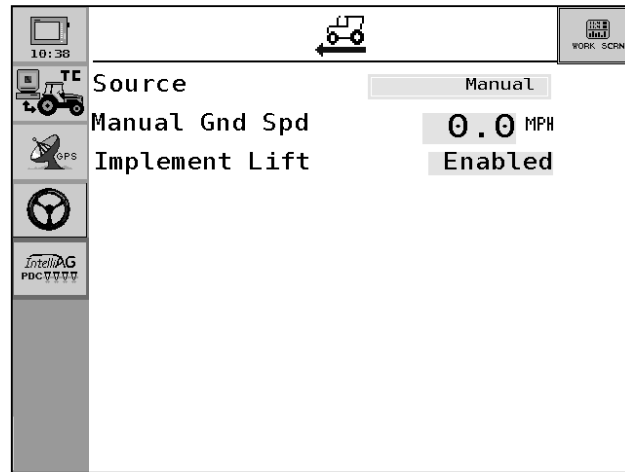
MANUAL

Sets the system to operate using a constant, internally generated ground speed. No ground speed sensor is required when using the Manual setting. No area accumulation will occur when speed source is manual.

Manual Ground Speed can be used in the event of a failure of the ground speed sensor being used. This is a constant, internally generated ground speed that will cause the system to operate when the master switch is ON at the speed that has been programmed. This value can be set to any speed within the delivery capabilities of the system.



Figure 71
Manual Ground Speed



RELUCT FREQ

Used when ground speed is provided by a reluctance (2-wire) type sensor connected to the actuator harness through an adapter harness.

DIGITAL FREQ

Used when ground speed is provided by a radar/digital (3-wire) type sensor connected to the actuator harness.

CAN GROUND

Used when ground speed is provided by a radar/digital (3-wire) type sensor connected to the cab harness or if radar/forward ground speed is communicated on the CAN bus.

CAN WHEEL

Used when wheel speed data is communicating on the CAN bus. This source does account for slip-like CAN ground.

GSPD CONSTANT

Ground Speed Constant is the value representing the pulse count produced by the ground speed sensor over a 400' distance. Refer to Ground Speed Calibration for additional information.

SHUT OFF SPEED

Shut Off Speed indicates the minimum ground speed allowed before the system shuts off all control channels.

MINIMUM OVERRIDE

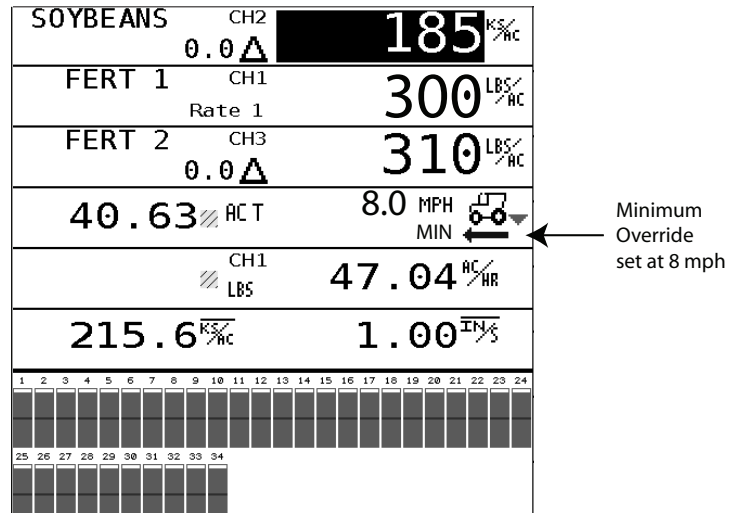
Minimum Override takes over when actual ground speed is below the designated value. The control will operate at this speed until actual ground speed rises above the minimum override speed or the actual speed drops below the shutoff speed.

NOTE: Manual ground speed can only be entered if the source is changed to MANUAL.



Figure 72

Minimum Override



MASTER SW TIMEOUT

Master Switch Timeout determines the length of time before the system disables the operate function after ground speed is 0 (zero) if the master switch remains in the ON position. After the delay time elapses, an alarm is issued stating that the master switch must be toggled OFF/ON before the system will restart.

GROUND FAIL ALARM DELAY

Alarm Delay determines the length of time after the ground speed goes to zero and seed flow continues before the alarm sounds. This alarm only applies when all control channels are disabled and the system is running in a Planter Monitor Only mode.

PRECHARGE GROUND SPEED

Precharge Ground Speed is the speed the system will use when Precharge has been enabled for a control channel and Precharge Ground Speed greater than 0 must be entered to operate.

FLUSH ENABLE SPEED

Flush Enable Speed is the speed the system will use when Flush Enable is pressed to open the valve and dispense material. The Flush Enable feature can only be activated when the implement is stopped.

IMPLEMENT LIFT

If an implement lift switch is used, the implement lift status must be enabled. While operating, an alarm condition will occur if the Master Switch is off for more than 5 to 10 seconds, the implement is down, and ground speed is greater than zero. An **Alarm Cancel** button allows the alarm to be deactivated during the current power cycle. If an implement lift switch is not required, this function should be disabled.



NOTE: Older DICKEY-john ground speed calibrations had a default value of 6096, which is the nominal pulse count for the radar speed sensor. ISO ground speed calibration has a default value of 12,192. To convert older DICKEY-john ground speed constants, multiply the recorded value by two for an approximate ISO conversion.



GROUND SPEED CALIBRATION

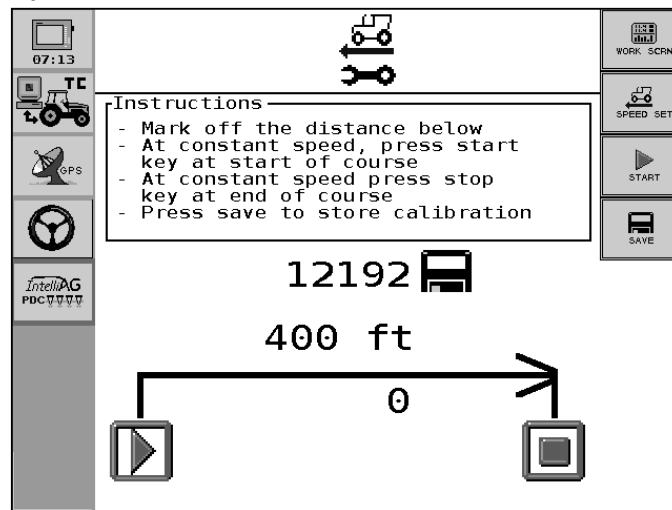
Ground speed is the rate in MPH (Km/h) as measured by the ground speed sensor. The number reflects the number of pulses generated by the ground speed sensor while traveling a distance of 400 feet (100 meters).

IMPORTANT: It is imperative to get an accurate ground speed reading, as this reading directly impacts the accuracy of population, area accumulation, and application rate control.

1. Press the **Speed Calibration** button to access the Ground Speed Calibration screen.

Figure 73

Ground Speed Calibration Screen



To Perform the Initial Ground Speed Calibration:

1. Carefully measure an exact 400 foot (100 meter) course, clearly marking the start and finish points.
2. With the tractor moving between 2 and 5 MPH (3.2 and 8 Km/h), press the **Start** button when the tractor is even with the designated start point. The display showing the ground speed calibration will zero and begin counting ground speed pulses.
3. When the tractor is even with the designated finish point, press the **Stop** button. The new calibration number will display on screen center.
4. To ensure accuracy, record the number and repeat this process two additional times. Average the three numbers recorded.
5. Enter the average calibration number.
6. **Save** the desired settings.





10" VT AUX INPUT/FUNCTION ASSIGNMENT

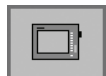
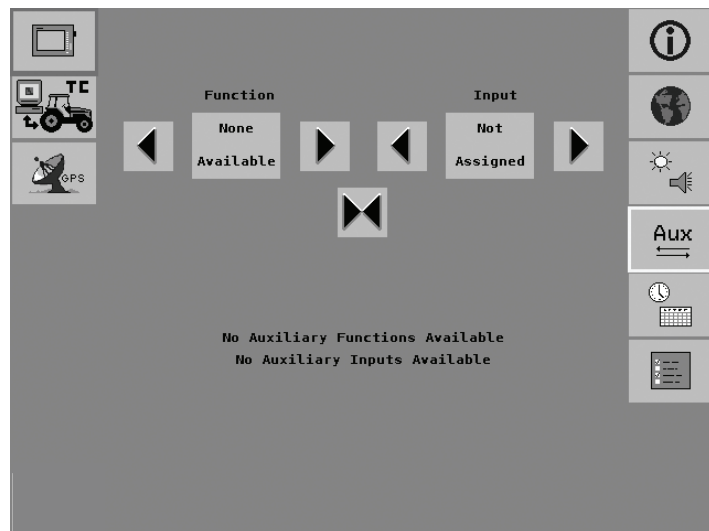
The Auxiliary Input/Function Assignment screen configures the system's master switch input to the TECU so that it will work with the IntelliAg control function.

IMPORTANT: On initial powerup, a **Master Switch Assignment** alarm activates requiring a switch assignment. If the master switch is not configured, the **Master Switch Assignment** alarm will activate at each power cycle until an auxiliary assignment is made and will default to the **Master Switch** button to activate auxiliary inputs.

An installed master switch located in the tractor cab is the preferred method for auxiliary input; however, a **Master Switch** button will be assigned and appear on the Work Screen if no physical switch assignment is made.

Figure 74

Aux Input/Function Assignment Screen



NOTE: For Virtual Terminals other than DICKEY-john, refer to the manufacturer's VT operator's manual for auxiliary assignment.

To assign the Master Switch to the IntelliAg:

1. Press the VT button.
1. Press the **Auxiliary Assignment** button.
2. At the Function box, use the right or left arrows to select the desired function (Control Channel icon).
3. At the Input box, use the right or left arrows to select the desired input (Tractor ECU master switch).
4. Press the **Enter** button to accept.

No Auxiliary Inputs Available appears on the screen if the Tractor ECU is not connected. When assigned, this line will disappear.

No Auxiliary Functions Available appears on the screen if the IntelliAg system is not connected. When assigned, this line will disappear.





5" VT AUX INPUT/FUNCTION ASSIGNMENT

The Auxiliary Input/Function Setup screen configures the location of the system's master switch. For proper assignment, the master switch must be configured correctly.

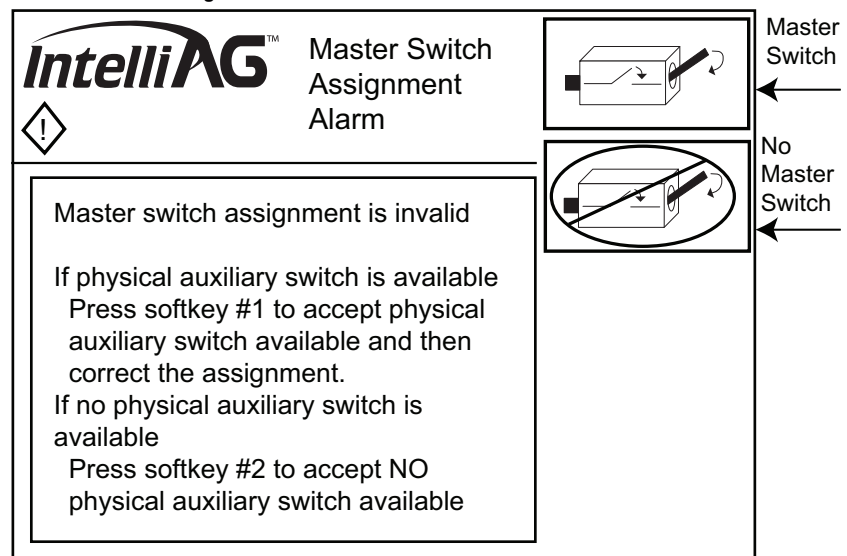
An installed master switch located in the tractor cab is the preferred method for auxiliary input; however a **Master Switch** button on the Virtual Terminal is available if there is no master switch installed in the cab.

On initial powerup, a Master Switch Assignment alarm activates requiring action (Figure 75).

- Press either the **Master Switch** button or
- Press the **No Master Switch** button

Figure 75

Master Switch Assignment Alarm



IMPORTANT: If the master switch is not configured, the master switch Assignment Alarm will activate at each power cycle until an auxiliary assignment is made and will default to the master switch button to activate auxiliary inputs.

MASTER SWITCH ASSIGNED

If assigning a master switch, the Virtual Terminal must be configured to acknowledge the assignment.

To Configure an installed master switch:

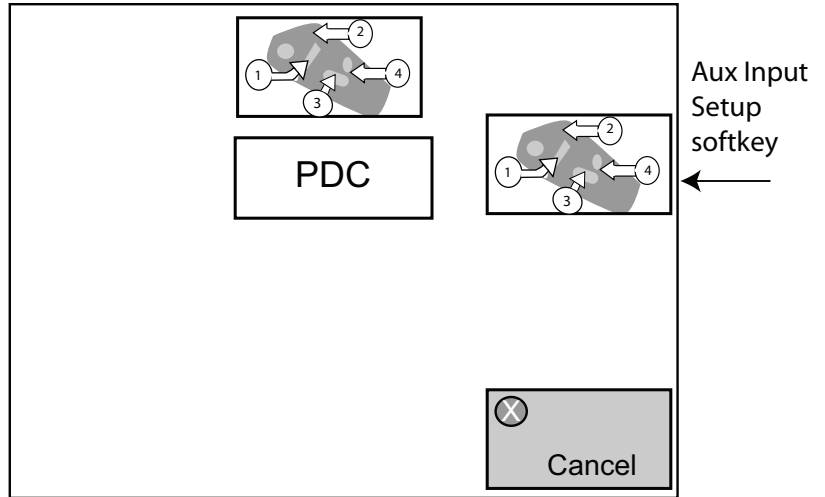
1. Press the **ESC** key 2 times to activate the Virtual Terminal Setup screen.
2. Press the **Auxiliary Input/Function Setup** button to access the Auxiliary Input/ Function Setup screen (Figure 76).





Figure 76

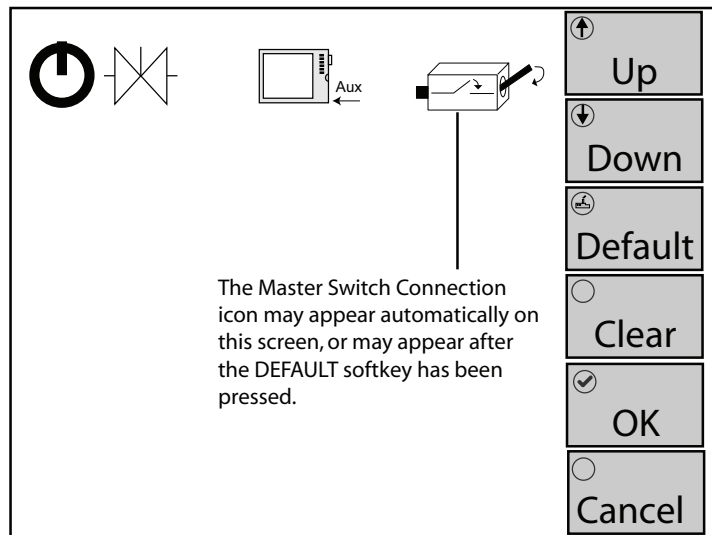
Auxiliary Input/Function Setup Screen



3. Navigate to the configuration screen by pressing the **Auxiliary Input Setup** button.
4. Press the **Default** button. A Master Switch Connection icon will appear on the screen indicating that the master switch is to be connected to the tractor cab harnesses' master switch connector (refer to [Figure 77](#)).
5. Press the **OK** button to save the configuration and return to the Aux Input/Function Setup screen.
6. Press and hold the **ESC** button for one or more seconds to return to the Virtual Terminal Setup screen.

Figure 77

Aux Input Configuration Screen





NO MASTER SWITCH ASSIGNED

When the No master switch icon is pressed, the Virtual Terminal assigns a master switch button to function as the auxiliary on and off keys.

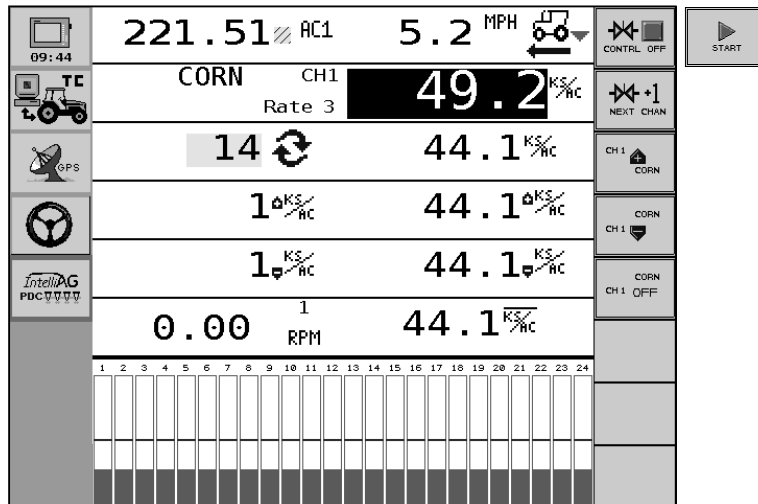
The Main Work screen will display with a **Control ON** button at the top of the screen.

toggling between the **Control ON and OFF** button cycles the system control on and off.



Figure 78

Main Work Screen with VT Master Switch Configured



IMPORTANT: As a safeguard, when the Control ON button is pressed, a Master Switch Button Activation alarm must be acknowledged before equipment operates (refer to Figure 30). This alarm occurs the first time the Master Switch button is pressed after every power up.



WORK SCREEN CONFIGURATION










A data item can be placed in any position by selecting the location on **Screen Configuration**. The display is functionally divided into 2 columns and 6 rows.

1. Press the **Work Screen** button to access **Screen Configuration**.
 - Any data item can be placed in any position.
 - Duplicate data items can be configured on a single display if desired.
 - Up to three display screens can be configured.
 - Some items selected for the work screen will display on one entire row.

After these values are selected, the new settings display on the configured work screens.

Figure 79

Work Screen Configuration Screen

 07:25	FIELD 1 AREA	GROUND SPEED	 WORK SCR
 TC	CONTROL INC/DEC 1	CONTROL ACTUAL CH 1	 1 2 NEXT SCR
 GPS	POP ROW SCAN NUMBER	POP ROW SCAN	
	POP MAX ROW NUMBER	POP MAX ROW	
 IntelliAG PDC	POP MIN ROW NUMBER	POP MIN ROW	
	RPM SCAN	POP AVG	
Bargraphs Setup Lines 1 Columns 24 Return Sys Active Delay SEC			



Refer to the Data Items section for a detailed description of each item and the associated display images.

In order to configure the second and third display screens, select the **Next Screen** button.

BARGRAPH SETUP

Bar graph setup allows customization of the rows being monitored and displayed on the Main Work screen. A maximum of 2 lines and 24 columns can display. Default displays 1 line and 24 columns.



RETURN SYSTEM ACTIVE DELAY

Setting a time delay (seconds) in the Return System Active Delay input box will trigger the IntelliAg Main Work screen to automatically return as the active screen view when other system application screens are used, i.e., Task Controller or Autopilot.

The delay time starts when the master switch is turned ON and the implement is in a down position. Delay time will not start unless both of these conditions are met.

IMPORTANT: This feature only operates with DICKEY-john virtual terminals.



SUMMARY SCREEN

The Summary screen provides an overview of setup constants for active control channels.

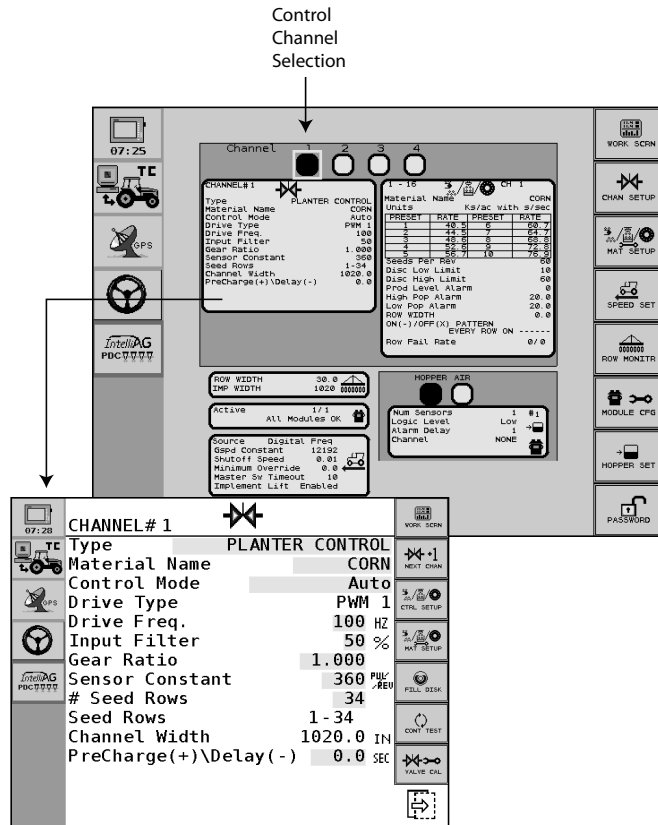
Press inside each box to access a setup screen for the following:

- Channel Setup
- Material Setup
- Row Monitor
- Module Configuration Setup
- Speed Set
- Hopper, Pressure, RPM Setup

1. At the Main Work screen, press the **Summary** button to access the Summary screen.

Figure 80

Summary Screen







DATA ITEMS

NOTE: *Data Items on the Main Work screen with a check box allows the number to be reset to zero.*



Data items are selected at Screen Configuration. The following illustrates available display parameters and their respective functions. Display parameter placement can be moved to display on the Main Work screen to individual preferences. Refer the System Configuration section for additional information on setting parameters.

CLEARING ACCUMULATORS

Some Data Item values can be reset to zero from the Main Work screen. Accumulator displays (e.g., Area 1 Field, Seed Count, etc.) on the active screen can be reset to zero by placing a check mark in the box next to the data item. Only accumulators that are on the currently-displayed screen can be reset. Accumulators are reset independently. They can only be reset when the master switch is OFF. Once an accumulator has reached its maximum value, it will roll over to 0.0.

CONTROL ACTUAL CHANNELS 1-4

CORN CH1
Rate 1 40.5 ^{KS}/_{AC}

NOTE: *All Data Items are selected from Screen Configuration. Refer to the Screen Configuration section for setup instructions.*

Control Actual Channels 1 - 4 display the channel actual application rates in its respective units depending on channel setup. The channel increment/decrement or preset table rate value also displays. When the master switch is OFF, the target rate displays in a small font for the channel. When the master switch is ON, the rate displays in a large font and is the actual application rate. When the channel's target rate is adjusted with the Inc/Dec or rate table function, the new target rates display for 5 seconds, followed by the actual rate. **This Data Item will display on an entire row of the Work screen.**

CONTROL TARGET CHANNELS 1-4

CORN CH1
Rate 1 40.5 * ^{KS}/_{AC}

Control Target Channels 1 - 4 display the channel target set rates depending on channel setup. The channel Inc/Dec value or preset table rate also displays. When the master switch is OFF, the rate displays in a small font. When the master switch is ON, the rate displays in a large font. **This Data Item will display on an entire row of the Work screen.**



CONTROL RATE CHANNELS 1-4

CORN CH1
 0.0 $\frac{\text{S}}{\text{SEC}}$ 40.5 $\frac{\text{KS}}{\text{AC}}$

Control Rate Channels 1-4 display the channel actual application rates depending on channel setup. The channels calculated flow rate displays. When the master switch is OFF, the rate displays in a small font. When the master switch is ON, the rate displays in a large font. When the channels target rate is adjusted using the Inc/Dec or Preset Table Rate function, the new target rate is displayed for 5 seconds followed by the actual rate. **This Data Item will display on an entire row of the Work screen.**

CONTROL SCAN

NITROGEN CH2
 Rate 1 98.1 $\frac{\text{LBS}}{\text{AC}}$

Control Scan displays all active control channels sequentially showing the actual rate in its respective units depending on channel setup, and the Inc/Dec value or preset table rate for each channel in five-second intervals. **This Data item will display on an entire row on the Work screen.**

POP ROW SCAN

5  0.0 $\frac{\text{KS}}{\text{AC}}$

NOTE: All Data Items are selected from the Work Configuration screen. Refer to the Work Screen Configuration section for setup instructions.

Pop Row Scan displays all active seed rows population in seeds per acre (or seeds/Ha) for each detected seed sensor. The value to the left side displays the current row number being scanned. The value on the right is the population data. The scans continue sequentially in four-second intervals unless a particular row number is selected for continuous view. **This Data Item will display on an entire row of the Work screen.**

POP MIN MAX ROW SCAN

3  $\frac{\text{KS}}{\text{AC}}$ 0.0  $\frac{\text{KS}}{\text{AC}}$

Pop Min Max Scan alternately displays the seeding row with the minimum population and the seeding row with the maximum population in seeds per acre (or seeds/Ha). The value to the left side displays the current row number. The value to the right is the population data. Dwell time for each display is four seconds. **This Data Item displays on an entire row of the Work screen.**



POP MIN ROW

4 $\frac{\text{KS}}{\text{AC}}$ 0.0 $\frac{\text{KS}}{\text{AC}}$

Pop Min Row displays the seeding row with the minimum population in seeds per acre (or seeds/Ha). The value to the left side displays the current row number. The value on the right is the population data. **This Data Item will display on an entire row of the Work screen.**

POP MAX ROW

1 $\frac{\text{KS}}{\text{AC}}$ 0.0 $\frac{\text{KS}}{\text{AC}}$

Pop Max Row displays the seeding row with the maximum population in seeds per acre (or seeds/Ha). The value to the left side displays the current row number. The value on the right is the population data. **This Data Item will be displayed on an entire row of the Work screen.**

POP AVG

0.0 $\frac{\text{KS}}{\text{AC}}$

Pop Avg displays the average population in seeds per acre (or seeds/Ha) of all active seeding rows per channel.

NOTE: All Data Items are selected from the Work Configuration screen. Refer to the Work Screen Configuration section for setup instructions.

SPACING ROW SCAN

1 $\frac{\text{IN}}{\text{S}}$ 0.00 $\frac{\text{IN}}{\text{S}}$

Spacing Row Scan scans all active seed rows and displays the spacing in inches (cm) for each row as detected by the sensors. The value to the left side displays the current row number. The value on the right is the population data. The scans continue sequentially in four-second intervals unless the rotary knob is used to select a particular row number for continuous view. **This Data Item displays on an entire row of the Work screen.**

SPACING MIN MAX ROW SCAN

1 $\frac{\text{IN}}{\text{S}}$ 0.0 $\frac{\text{IN}}{\text{S}}$

Spacing Min Max Row Scan alternately displays the seeding rows with the minimum and maximum spacing in inches (cm). The value to the left side is the current row number. The value on the right is the spacing. Dwell time for each display is four seconds. **This Data Item displays on an entire row of the Work screen.**



SPACING MIN ROW

1 IN/S 0.0 IN/S

Spacing Min Row displays the seeding row with the minimum spacing in inches (cm). The value to the left side displays the current row number. The value on the right is the spacing. **This Data Item displays on an entire row of the Work screen.**

SPACING MAX ROW

1 IN/S 0.0 IN/S

Spacing Max Row displays the seeding row with the maximum spacing in inches (cm). The value to the left side displays the current row number. The value on the right is the spacing. **This Data Item displays on an entire row of the Work screen.**

SPACING AVG

0.0 IN/S

Spacing Avg displays the average spacing in inches (cm) of all active seeding rows per channel.

NOTE: All Data Items are selected from the Work Configuration screen. Refer to the Work Screen Configuration section for setup instructions.

SEED/DISTANCE ROW SCAN

1 0.0 S/FT

Seed/Distance Row Scan displays all active seed rows and the number of seeds per foot (seeds/meter) for each row detected by the sensors. The value to the left side displays the current row number. The value on the right is the seeds per distance data. The scan continues sequentially in four-second intervals unless a particular row number is selected for continuous view. **This Data Item displays on an entire row of the Work screen.**

SEED/DISTANCE MIN MAX ROW SCAN

1 S/FT 0.0 S/FT

Seed/Distance Min Max Row Scan alternately displays the seed row with the minimum number of seeds per foot (seeds/meter) and the seeding row with the maximum number of seeds per foot (seeds/meter). The value to the left side displays the current row number. The value on the right is the seeds per distance data. Dwell time for each display is four seconds. **This Data Item displays on an entire row of the Work screen.**



SEED/DISTANCE MIN ROW

1 $\frac{S}{ft}$ 0.0 $\frac{S}{ft}$

Seed/Distance Min Row displays the seeding row with the minimum number of seeds per foot (meter). The value to the left side displays the current row number. The value on the right is the seeds per distance data. **This Data Item displays on an entire row of the Work screen.**

SEED/DISTANCE MAX ROW

1 $\frac{S}{ft}$ 0.0 $\frac{S}{ft}$

Seed/Distance Max Row displays the seeding row with the maximum number of seeds per foot (meter). The value to the left side displays the current row number. The value on the right is the seeds per distance data. **This Data Item displays on an entire row of the Work screen.**

SEED/DISTANCE AVERAGE

0.0 $\overline{\frac{S}{ft}}$

Seed/Distance Average displays the average number of seeds per foot (meter) of all active seeding rows per channel.

NOTE: All Data Items are selected from the Work Configuration screen. Refer to the Work Screen Configuration section for setup instructions.

SINGULATION AVERAGE

0 %

Singulation Average displays the average percent seed singulation of the planter's rows that are configured for population. Singulation refers to the portion of seeds planted individually, rather than in groups.

NOTE: Singulation information is only operable when using a Smart Harness system and Seed Smart sensors. Contact DICKEY-john Technical Support at 1-800-637-3302 for additional information.

SINGULATION ROW SCAN

1 0 %

Singulation Row Scan displays the percent singulation of each of the planter's rows. The displayed row increments every four seconds. After the last row is displayed, the scan will re-sequence beginning with the first active row.

SINGULATION MIN MAX SCAN

1 0 %

Singulation Min Max Scan alternates the display of the minimum row singulation and maximum row singulation every two seconds. When a minimum row displays, the corresponding symbol is shown with the row number.



GROUND SPEED

7.7 MPH

Ground Speed displays the current ground speed of the tractor in miles per hour (Kph). The ground speed source is defined during the Ground Speed Calibration setup. This data item also displays the implement status using an up/down arrow next to the tractor icon.

TOTAL AREA

0.00 ACT

NOTE: Data Items on the Main Work screen with a check box allows the number to be reset to zero.

Reset box
0.00 ACT

Total Area displays the area covered by the implement in acres (Ha). Total area is calculated using the Implement Width parameter entered on the **Row Status/Row Width Setup** screen. Area accumulates for seeding when seeds are detected on at least one seeding row and the ground speed is above the Shutoff Speed parameter entered on the **Ground Speed Calibration** screen. This accumulator is independent of any other area accumulator and can be reset to 0.0 at any time. Current area is retained after power down. If no rows are configured, the Total Area Accumulator will use the largest channel width.

NOTE: All Data Items are selected from the Work Configuration screen. Refer to the Work Screen Configuration section for setup instructions.

FIELD 1 AREA

0.00 AC1

Field 1 Area displays the area covered by the implement in acres (Ha). Field 1 Area is calculated in the same manner as Total Area. This accumulator is independent of any other area accumulator and can be reset to 0.0 at any time. Current area is retained after power down.

FIELD 2 AREA

0.00 AC2

Field 2 Area displays the area covered by the implement in acres (Ha). Field 2 Area is calculated in the same manner as Total Area. This accumulator is independent of any other area accumulator and can be reset to 0.0 at any time. Current area is retained after power down.



CHANNELS 1 - 4 AREA

Reset
↓
✕

10.95 ■ 1AC

Channels 1 - 4 Area displays the area covered by Control Channels 1 - 4. Area is calculated using the Channel Width parameter that is entered on the **Control Channel setup** screen. Area accumulates when the master switch is ON and the ground speed is above the Shutoff Speed parameter entered on the **Ground Speed Calibration** screen. This accumulator is independent of any other area accumulator and can be reset to 0.0 at any time. Current area is retained after power down.

AREA SCAN

0.00 AC1

Area Scan scans through all area accumulators sequentially displaying the area for each accumulator in four-second intervals.

NOTE: All Data Items are selected from the Work Configuration screen. Refer to the Work Screen Configuration section for setup instructions.

CONTROL FEEDBACK SCAN

0.0 CH2
RPM

Feedback Scan scans through all active control channel feedback sensors sequentially displaying the actual RPM or GPM measured in four-second intervals. The current sensor is identified by the number displayed above the RPM symbol (planter control, granular seeding, granular fertilizer) or GPM symbol (liquid flow).

AREA PER HOUR

0.00 ^{AC}/_{HR}

Area Per Hour displays the current area per hour in acres (Ha). The value is continuously calculated based on the current ground speed and the Implement Width parameter as entered on the **Row Status/Row Width Setup** screen.

SYSTEM ACTIVE TIME

Reset
↓
✕

0.00 ■ HR

System Active Time records the amount of time the master switch is in the ON position indicating the actual number of hours equipment has been operating.



SEED COUNT ACCUM ROW



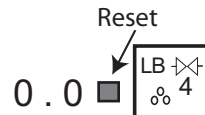
Seed Count Accum Row scans through all of the active seed rows and displays the seed count for each row as detected by the seed sensors. The value to the left side displays the current row number. The value to the right is the seed count. The scan continues sequentially in four-second intervals unless a particular row number is selected for continuous view. The Seed Count function is enabled/disabled on the Accumulators/Seed Count/Distance Count screen. **This Data Item displays on an entire row of the Work screen.**

DISTANCE ACCUMULATOR



Distance Accumulator displays the distance covered in feet (ft). This accumulator is independent of any other area accumulator and can be reset to 0.0 at any time. Current distance is retained after power down.

CHANNELS 1 - 4 MATERIAL ACCUM



Channels 1 - 4 Material Accum displays the current accumulated material for Channels 1 - 4. Material is accumulated according to the applied rate. Does not function if channel is planter control.

NOTE: All Data Items are selected from the Work Configuration screen. Refer to the Work Screen Configuration section for setup instructions.

ACCESSORY INPUT SCAN

PRESSURE SCAN



Pressure Scan scans through all active pressure sensors sequentially, displaying the actual pressure measured in oz/in² (kPa) in four-second intervals. The current sensor is identified by the number above the pressure symbol.




RPM SCAN

0.0 ¹ RPM

RPM Scan scans through all active shaft/fan sensors sequentially, displaying the actual RPM measured in four-second intervals. The current sensor is identified by the number displayed above the RPM symbol.

CHANNEL 1-4 PRODUCT LEVEL

0  CH1
LBS

Channels 1-4 Product Levels indicates how much product remains in the hopper or tank. The Reset button is unique in that it does not reset the value to zero but allows the user to set the known amount of product added. Selecting the Reset button thereafter will default to the original amount entered. To enter the starting product level, select the value and change to the desired level.

HOPPER LEVEL STATUS SCAN

1 

Hopper Level Status Scan scans through all the hopper level sensors in the system and indicates an empty or nonempty status.



NOTE: All Data Items are selected from the Work Configuration screen. Refer to the Work Screen Configuration section for setup instructions.

BOOM STATUS

1 
↑
Boom #

Boom Status indicates the status of each boom section. The Boom Status feature is only operational with Liquid Control channels when a DICKEY-john boom switch module and boom output module are installed for boom control. This Data Item will scan through 12 sections at a time on an entire row.

GUIDANCE STATUS

AB0 0.00 IN  
30% Swath Complete | DISABLED

AutoPilot can be engaged and disengaged from the Main Work screen. AB line position, cross-track error, and % of swath completion will also display. **This Data Item displays on an entire row of the Work screen.**





PRE-OPERATING PREPARATION

Planters should perform a fill disk at every system startup or a variety/seed-type change. This will ensure no voids are left in the field when starting to plant.



FILL DISK FOR ALL CONTROL CHANNELS

1. From the Main Work screen, press the **Planter Fill Disk** button.
2. Raise the implement.
3. With brakes locked and transmission in the park position, start the engine.
4. Engage hydraulics and run engine at normal speed until hydraulic fluid is at operating temperature.



Implement will begin to operate after pressing the Start button. Ensure that all persons and objects are away from the implement to avoid personal injury.



5. Press the **Start** button. The seed meters will turn for 1 revolution, then stop.
6. Pressing the **Stop** button will also terminate the test.

Figure 81

Fill Disk Screen for All Planter Controls







SYSTEM OPERATION

START

1. Lower the implement to operating position, engaging the implement switch, if present and enabled.
2. With the hydraulic system engaged and the tractor at its normal operating RPM, set the master switch to the On position. All enabled control channels will begin controlling at the current ground speed. All accumulators will begin recording data.

⚠ WARNING

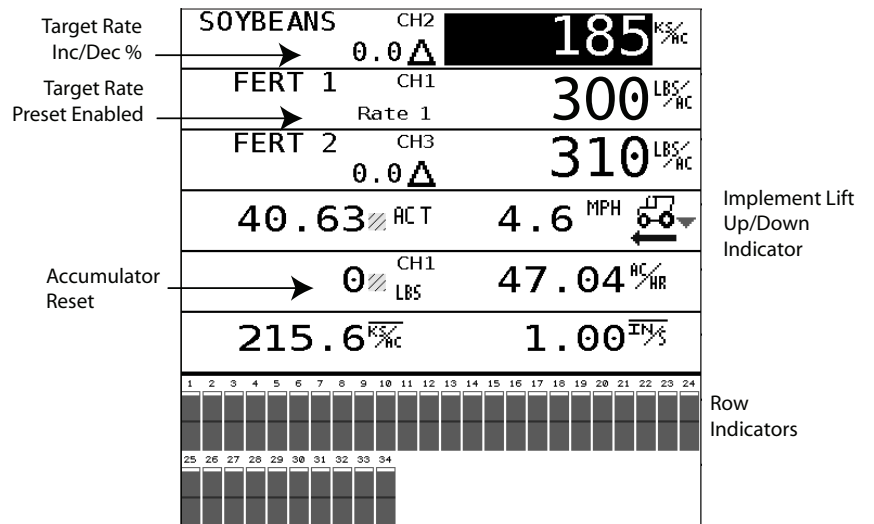
When the implement is down and the master switch in the On position, the machine is fully operational. All necessary precautions must be taken to ensure user safety. Failure to practice all necessary caution may result in serious injury or death.

STOP

1. Set the master switch to the Off position. All control channels will cease operation and all data accumulation will halt.
2. Operation will immediately stop when the ground speed is 0 or the implement is raised to disengage.

Figure 82

Main Work Screen Functions





OPERATE SCREEN SYMBOLS



TARGET RATE

The Target Application Rate displays when Master Switch is off. The actual applied rate appears during Operate mode.



INCREASE/DECREASE % RATE

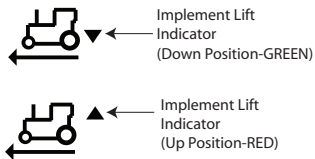
The Increase/Decrease rate is the percentage change being applied each time the Material Increase/Decrease button is pressed during Operate mode.

RATE 1

TARGET PRESET RATE

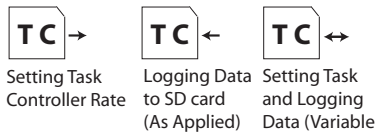
The Preset Rate is the applied rate that was entered at the Material Configuration Setup screen and increases or decreases when the **Material Increase/Decrease** button is pressed during Operate mode.

IMPLEMENT LIFT SWITCH



When an implement lift switch is installed, the Main Work screen will identify if the implement is in the up or down position. Using an implement lift switch automatically turns the control channels on and off without turning the master switch off. The Implement Lift Indicator must be in the Down position for the control channels to operate. **The Implement Lift Switch box on the Ground Speed Configuration screen must be enabled if an implement lift switch is used.**

Refer to the Implement Lift Sensor instructions for installation location.



TASK CONTROLLER

The Task Controller icon appears on the Main Work screen when Task Controller is active and controlling the application rate. Return to Task Controller to stop a task.

ROW INDICATORS

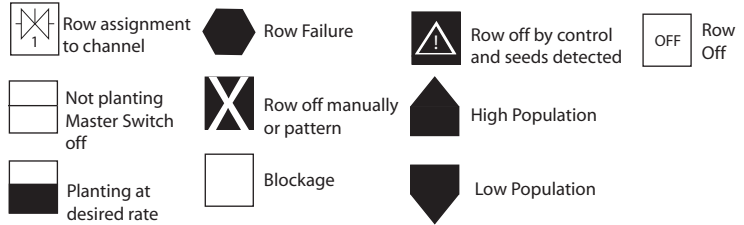
Row Indicators in the bar graph area on the bottom of the Work screen indicate seed rate for each row. The size of the bar graphic is set on the Work Configuration screen by pressing the **Work Screen** button.



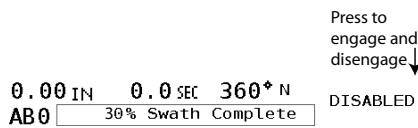
The following symbols illuminate in the bar graph area:

Figure 83

Row Indicator Symbols

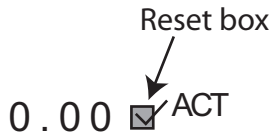


AUTOPILOT STEERING NAVIGATION



Autopilot Steering Navigation can be engaged and disengaged from the Main Work screen and displays swath # (AB0), cross-track error (0.00 IN), age of correction (0.0 SEC), heading direction (360 degrees), and % swath complete.

ACCUMULATORS



Some Data Item values can be reset to zero from the Main Work screen. An accumulator displays (e.g., Area 1 Field, Seed Count, etc.) on the active screen and can be reset to zero by placing a check mark in the box next to the data item. Only accumulators on the currently-displayed screen can be reset. Accumulators are reset independently and can only be reset when the master switch is OFF. Once an accumulator has reached its maximum value, it will roll over to 0.0. (Figure 82) identifies an Accumulator icon.

POPULATION ROW SCAN



Pop Row Scan displays all active seed rows population in seeds per acre (or seeds/Ha) for each detected seed sensor. The value to the left side displays the current row number being scanned. The value on the right is the population data. The scans continue sequentially in four-second intervals unless the rotary knob is used to select a particular row number for continuous view. **This Data Item displays on an entire row of the Work screen.**

SINGULATION AVERAGE POPULATION



Singulation Average displays the average percent seed singulation of the rows that are configured for population. Singulation refers to the portion of seeds planted individually, rather than in groups.

MATERIAL NAME



Active Material Name for a control channel created at the Control Channel screen.



1  $\frac{KS}{AC}$ 0 . 0  $\frac{KS}{AC}$

POPULATION MAX ROW

Pop Max Row displays the seeding row with the maximum population in seeds per acre (or seeds/Ha). The value to the left side displays the current row number. The value on the right is the population data. **This Data Item displays on an entire row of the Work screen.**

4  $\frac{KS}{AC}$ 0 . 0  $\frac{KS}{AC}$

POPULATION MIN ROW

Pop Min Row displays the seeding row with the minimum population in seeds per acre (or seeds/Ha). The value to the left side displays the current row number. The value on the right is the population data. **This Data Item displays on an entire row of the Work screen.**

PRECHARGE FEATURE

The Precharge feature is typically used in applications that have significant distance between the storage bulk tank and the implement row unit where seed placement takes several seconds due to the travel time of the seed/fertilizer from the bulk tank to the ground. When the precharge feature is activated, material will dispense at the rate at which the precharge ground speed is set.

The precharge feature will operate until the precharge time lapses or the precharge ground speed has been exceeded. If ground speed stops while in precharge mode, the feature will abort.

A precharge alarm will display any time the preset feature is established or changed and the master switch is turned on.

The precharge feature is applicable to planter control, granular seeding, fertilizer and liquid control channels.

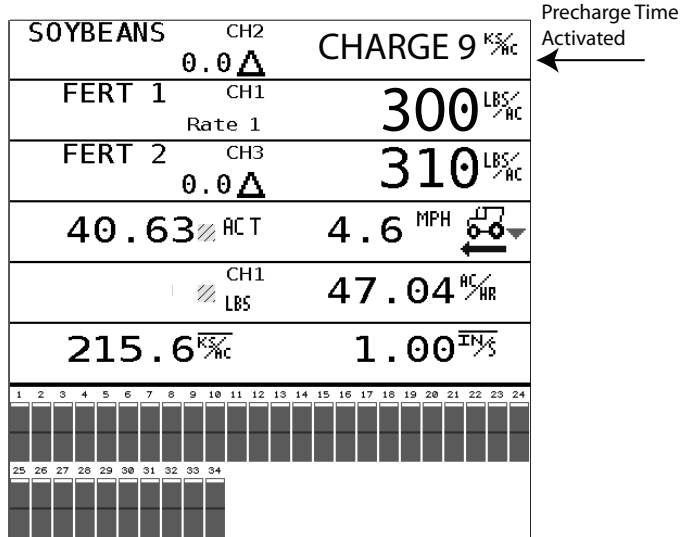
NOTE: Master switch must be turned ON to activate a precharge state.

Reference the System Configuration section for control channel and ground speed setup instructions.



Figure 84

Precharge Time and Ground Speed (Main Work Screen)



Operating the Precharge function:

1. Turn the master switch on.
2. The precharge feature will automatically initiate when the master switch is turned on and the ground speed is less than the precharge ground speed but greater than 0.

The rate instrument will populate with the word "CHARGE" and the countdown timer. The timer gives the user the ability to see how much precharge time is left before precharge will abort.



NOTE: *Flush Enable will abort if the button is pressed during a Precharge state.*



FLUSH ENABLE

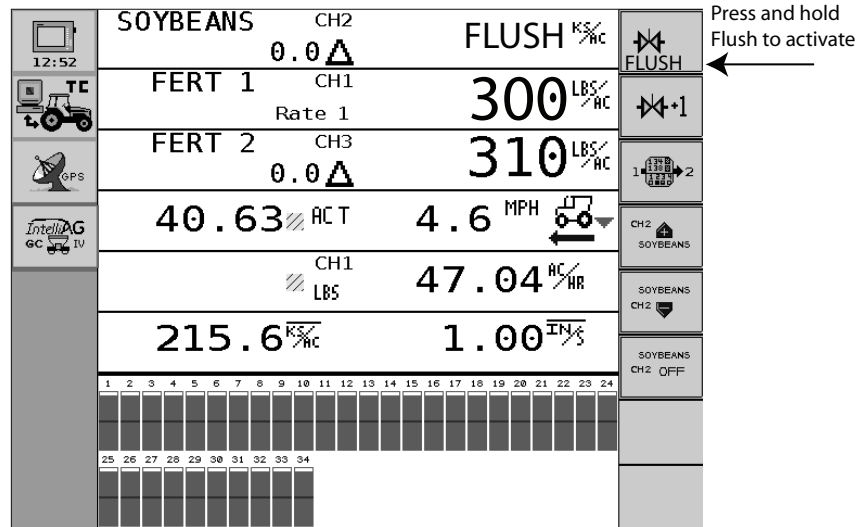
The Flush Enable feature is typically used to begin dispensing material at a higher rate when the tractor is below shutoff speed, i.e. during startup or turn around conditions. Material will dispense at the rate set at the ground speed setup screen.

Flush enable is applicable to granular seeding, fertilizer, or liquid control channels.

Reference System Configuration for control channel and ground speed setup instructions.

Figure 85

Flush Enable (Main Work Screen)



Operating the Flush Enable function:

1. Ensure the master switch is turned ON.
2. Press and hold the **Flush Enable** button to dispense material.
3. Release the **Flush Enable** button to stop dispensing material. Once speed is above shutoff speed, flush is aborted and ground speed based control will take over.



SYSTEM INFORMATION AND DIAGNOSTICS

In order to view the following information and diagnostics screens, the master switch must be set to the OFF position.

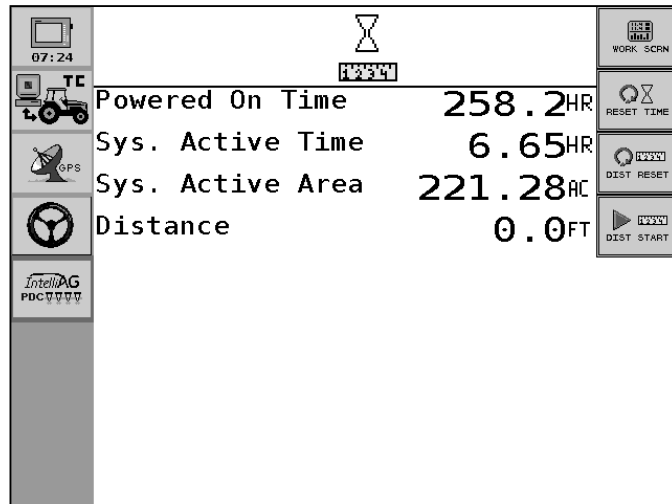
SYSTEM ACCUMULATORS SCREEN

The System Accumulators screen displays the amount of time the system has been on, the amount of time and area application control has occurred, and the distance traveled. Data on this screen is for display purposes only - it cannot be edited.

Press the **System Accumulators** button to access the Accumulators screen.

Figure 86

System Accumulators Screen



NOTE: The Master Switch must be set to the OFF position to display the **System Accumulators** screen.

POWERED ON TIME

Powered On Time is the accumulated time, in hours, that the system has been powered ON. Powered On Time accumulates regardless of the mode of operation - whether it is in SETUP/CONFIGURATION mode or OPERATE mode. Powered On Time cannot be reset.

SYSTEM ACTIVE TIME

System Active Time is the accumulated time, in hours, that the machine has actively been controlling. System Active Time accumulates whenever seeds are detected on at least one sensor. Planting time does not accumulate during an ALL ROWS FAILED condition. System Active Time can be reset by pressing the **Reset Time** button.

SYSTEM ACTIVE AREA

System Active Area is the accumulated area covered while the Master Switch is on. System Active Area cannot be reset.





DISTANCE

Distance is the accumulated distance, in feet (meters) that the implement has travelled. The Distance accumulator function can be controlled by using the following procedures:

1. Press the **Start Distance** button to begin accumulating distance. This occurs whenever there is ground speed.
2. Press the **Stop Distance** button to stop distance accumulation.
3. Press the **Reset Distance** button to reset the value back to 0.0.



DIAGNOSTICS

The Diagnostics screen provides various information from feedback sensors, valve output, and system voltages of the WSMT module. The control valve can be manually opened on this screen when necessary. Refer to VALVE CALIBRATION for additional information.

Each channel has its own Diagnostics screen. None of the items on the screen may be edited. However the Channel Pulse Count data can be reset. The system may be active while the Diagnostic screen is displayed.

Press the **Diagnostics** button to access the Diagnostics screen.



Figure 87

Diagnostics Screen

07:17	CHANNEL # 4		
	RPM		
	CH SETPOINT	0.0000	
	CH TARGET	700	
	CH ACTUAL RATE	0.00	
	CH RPM	0.0000	
	CH PWM	0	
	CH PULSE COUNT	0	
	CH FREQ FILT	0	
	FREQ REL GSPD	224	
	FREQ DIG GSPD	224	
	IO HOPPER #1	0	
	FREQ AIR PRESS #1	249	
	IO IMP LIFT	0	
	APP ID	0.52	
	SOL PWR VOLT	14.60	
	ECU PWR VOLT	14.61	
	SNSR PWR VOLT	8.02	
	GND VOLT	0.00	

CH SETPOINT

The Channel Setpoint value is calculated by the system. It displays the expected feedback frequency of the application rate sensor or flowmeter used for that channel's feedback.

CH TARGET

The Channel Target value is the current channel's rate as entered into the Target Rate constant on the Channel Configuration screen.



CH ACTUAL RATE

The Channel Actual Rate value is the current channel's actual controlled rate with the system active.

CH RPM/GPM

The Channel RPM/GPM value is the current RPM (revolutions per minute)/GPM (gallons per minute). The sensor constant and gear ratio parameters entered on the Channel Configuration screen allow the RPM/GPM to be calculated.

CH PWM

The Channel PWM value is the current pulse width modulation (PWM) output drive signal to the solenoid valve. The higher the number, the further the valve opens.

CH PULSE COUNT

The Channel Pulse Count value is the accumulated pulse count detected from the channel feedback sensor. This value may be reset by the operator by pressing the Reset Channel Pulse Count button.

CH FREQ FILT

The Channel Frequency's Filtered value is the filtered frequency output from the channel feedback sensor.

FREQ REL GSPD

The Frequency Reluctance Ground Speed value is the reluctance sensor output signal in hertz (hz). This value is present when ground speed is provided by a reluctance sensor connected to the actuator harness.

FREQ DIG GSPD

The Frequency Digital Ground Speed value is the digital sensor output signal in hertz (hz). This value is present when ground speed is provided by a radar sensor or other digital speed sensor connected to the actuator harness.

FREQ PRESS 1

The Frequency Pressure value is the output frequency signal of the air pressure sensor in hertz (hz). This value will typically fall between 200 hz and 1100 hz.

IO HOPPER 1

The IO Hopper 1 value is the current state of the hopper sensor. If the sensor is not blocked, the value will be "1". A blocked sensor's value will be "1".

NOTE: In some instances, FREQ REL GSPD and FREQ DIG GSPD read the same values simultaneously depending upon the sensor used. This is normal and does not impact operation.



NOTE: If the values are reversed and the value displays a "1" when the implement is raised, the wiring for the implement switch will need to be reversed so that an accurate readout is achieved.

IO IMP LIFT

The IO Implement Lift value displays the current state of the implement status switch. This value will be "1" when the implement is down. The value will be "0" when the implement is raised.

APP ID

Hardware identification only. Not applicable to the end user.

SOL PWR VOLT

The Solenoid Power Voltage value displays the detected solenoid power voltage. This voltage level is the high current voltage leg of the system which is used to power high current solenoids and valve actuators. This value will generally be equal or nearly equal to the tractor battery voltage.

ECU PWR VOLT

The Electrical Control Unit (ECU) Power Voltage value is the detected ECU voltage. This voltage level is the low current voltage leg of the system and is used to power modules and sensors. This value will generally be equal or nearly equal to the tractor battery voltage.

SNSR PWR VOLT

The Sensor Power Voltage value is the detected output voltage to the seed sensor on the Working Set Master (WSMT) module. This value is typically +8 VDC.

GND VOLT

If the system is properly grounded, this value is typically 2.50V on software versions older than 2.7. Software versions newer than 2.7 and WSMT software is 0V.

DIAGNOSTICS MANUAL VALVE POSITION

Manual opening of a selected channel's valve is used for calibration or troubleshooting purposes in the case of system failure.

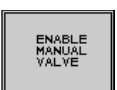
Press the **Diagnostics** button to access the Diagnostics screen.

1. The Diagnostics screen will show Channel 1 as a default.
 - If a channel other than Channel 1 needs to be selected, press the **Next Channel** button until the appropriate channel displays. The **Next Channel** button only displays when more than one channel is configured.

MANUAL OPEN OF CHANNEL

1. Press the **Enable Manual Valve** button to run the current selected channel. This allows for manual open and close of valve position.

IMPORTANT: The Enable feature will only operate on the Diagnostics screen.





2. If the **Disable Manual Valve** button is displayed, the selected channel has already been enabled for manual valve position operation.
3. Set the Master Switch to the ON position.
4. Press the **Increment** button to open the channel's valve. The Channel Pulse Width Modulation (PWM) data item displays the current PWM signal that is being output to the valve.
5. The **Increment** button must be pressed repeatedly to increase the PWM signal to the valve. Each press will increase the signal by 2 hertz (hz). The Channel Pulse Count and Channel Frequency Filter values will display the current output of the feedback sensor.
6. Press the **Decrement** button to decrease the PWM signal and close the valve. The **Decrement** button must be pressed repeatedly to decrease the PWM signal to the valve. Each press will decrease the signal by 2 hertz (hz).
7. The active channel is displayed in the button text.
8. Turn the master switch off to shutdown control channel.

SEED COUNT SCREEN

The Seed Count screen displays the number of seeds detected by each sensor. Individual seed rows can be assessed and seed counts for those rows may be accumulated. Up to 15 row numbers can display at one time.

Press the **Seed Count** button to display the Seed Count screen.



Figure 88

Seed Count Screen



	1,2,3...			
07:29				WORK SCRIN
TC	1	2	3	DIAGNOSTIC
	18840	18821	18821	
GPS	4	5	6	CNT RESET
	18821	18821	18821	
	7	8	9	STOP
IntelliAG PDC	18821	18821	18821	NEXT ROWS
	10	11	12	
	18821	18821	18821	5 REV
	13	14	15	
	18821	18821	18821	

Operating the Seed Count function:

1. Press the **Start** button. Seed count data for each sensor will accumulate when seeds drop through the sensor.
2. Press the **Next Rows** button to view additional rows.
3. Press the **Stop** button to stop the seed count function.
4. To reset the seed count on all rows, press the **Count Reset** button.
5. Press the **Work Screen** button to exit or press the **Accumulators** button to return to the Accumulator screen.



INFORMATION SCREEN

The Information screen displays the module software versions connected to the system and is typically used for troubleshooting. No information on the screen can be edited.

Each module connected is identified by module type, module position, and serial number. Module position cannot be altered on this screen and can only be established on the Module Configuration screen.

Press the **Information** button to access the Information screen.



Figure 89

Information Screen

The screenshot shows the Information Screen with the following data:

MOD	POS	APP	BOOT
1	1	03.99 09 02 06 07	01.00 07 04 09 14
WSMT-PDC			
S/N 10003 P/N P03 99 01			
2	2	03.00 07 01 24 15	02.00 06 10 31 08
WSMB-18R			
S/N 10259			

Navigation buttons on the right side include: WORK SCR, DIAGNOSTIC, MODULE CFG, and PASSWORD. A 'Software Version' label points to the APP and BOOT columns.



RESETTING NOVAM VALUES

NOVRAM refers to the memory location of the Working Set Master (WSMT) module where all configuration and setup data for the system are stored. Resetting the NOVAM will reset all data to factory default constants.

1. From the Main Work screen, press the **Diagnostics** button.
1. At the Diagnostics screen, press the **Memory Reset** button to access the Memory Reset screen.
2. Press the **Reset Novram** button to reset to factory standard defaults.
3. Press the **Diagnostics** button to return to the Diagnostics screen.

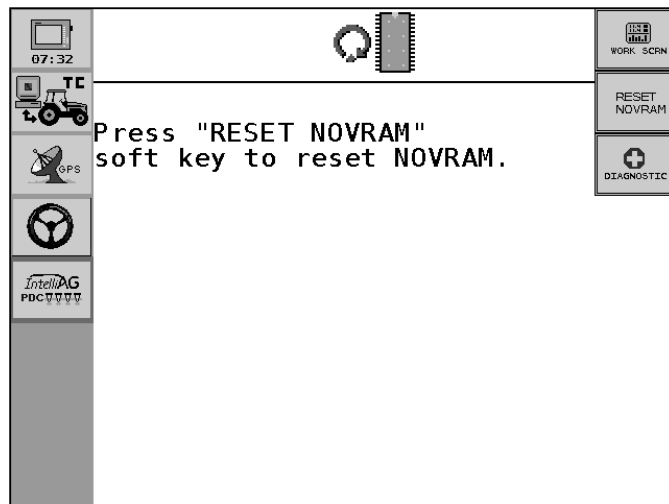


CAUTION

DO NOT press the NOVAM Reset button unless you want **ALL** system data settings to be reset to factory standard defaults. It is recommended that NOVAM not be reset unless instructed by DICKEY-john Technical Support.

Figure 90

Reset Novram Screen



ACKNOWLEDGING ALARM CONDITIONS

Various alarm conditions may be presented to the operator whenever the system encounters an abnormal condition or detects a specific alarm. Alarms are typically in a full screen display describing the alarm and, dependent upon the alarm type, may give the operator instructions on how to fix the alarm. Each alarm type has an associated alarm number, which can be cross-referenced in the TROUBLESHOOTING AND ALARMS section.

Some alarms (such as the Master Switch alarm) require a specific action by the operator before the alarm condition will cease. In these cases, instructions are indicated on the alarm display.



Other alarms can be acknowledged by pressing the **Alarm Cancel** button of **ESC** key. Detailed information about the alarm can be accessed by pressing the **Alarm Detail** button.

ALARM LOG

The Alarm Log screen provides a list of specific alarms that have been issued during system operation. Information displayed on the Alarm Log screen is informational only and cannot be edited.

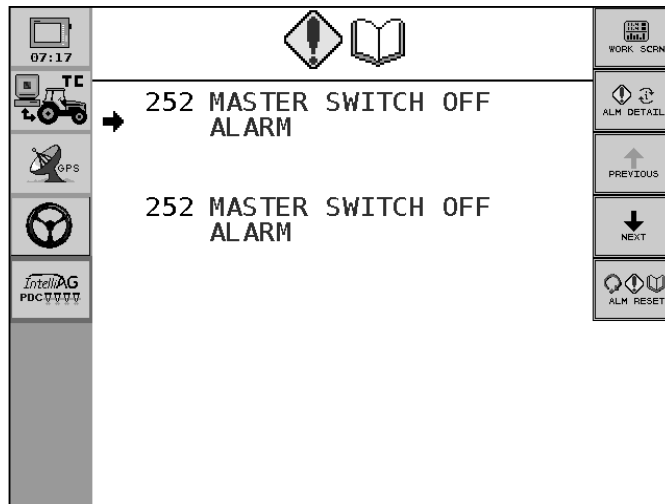
Each time specific alarm conditions are detected, it is logged and communicated to the WSMT.

To View Alarm Log:

1. Press the **Alarm Log** button to access the Alarm Log screen.
 - The number of the alarm, along with the alarm description displays.
 - Up to 20 alarms may be recalled.
 - Each alarm occurrence can have up to 5 instances of the alarm tagged with a date and time stamp.
2. To select specific Alarm details, press the **Previous** or **Next** buttons to move the small display arrow next to the desired alarm number.
3. Press the **Alarm Detail** button to view all of the occurrences of the selected alarm.
 - The down arrow in the lower left at screen bottom signifies that more alarms are present and accessible by pressing the **Previous** or **Next** buttons.

Figure 91

Alarm Log Screen



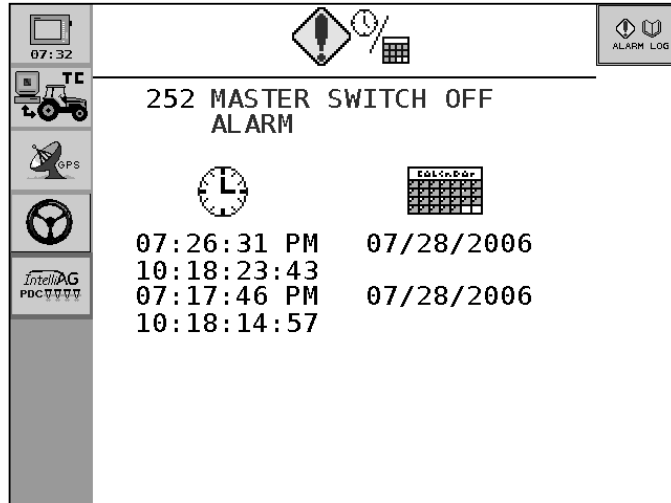


ALARM DETAIL

1. To view specific alarm details, press the **Alarm Detail** button.
 - The time and date of the selected alarm displays for each occurred instance.
 - The Alarm Log will save up to 5 instances of the selected alarm.

Figure 92

Alarm Detail Screen



ALARM RESET

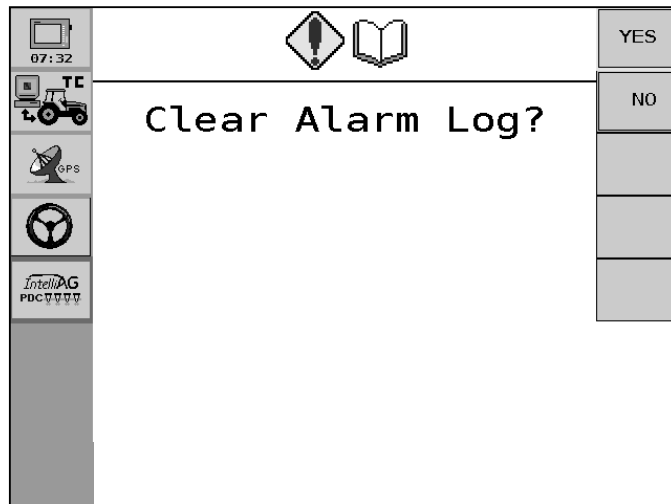
To reset the Alarm Log, press the **Alarm Reset** button.

1. Press **YES** button to clear.
2. Press **NO** button to return to Alarm Log Detail screen.



Figure 93

Reset Alarm Log Screen







TASK CONTROLLER

The following functionality is specific to those systems using Task Controller. Systems with no file server or task controller functionality will not have the below features.

IMPLEMENT OFFSET

To determine implement offset, the Y coordinates are required entries to establish the calculation from the center of each control channel location to the rear hitch connection in inches. The vehicle coordinates for each control channel are used to calculate Field Area 1, 2, and Total Area accumulators.

NOTE: For those systems using Task Controller, both X and Y coordinate entries are required for GPS navigation and field area accumulators. Reference the Task Controller section for setup instructions.

IMPORTANT: A Control Channel Type must be established first before implement coordinates can be entered. A channel type established as an RPM Control will not allow entry of x, y coordinates.

NOTE: Position of coordinates to the hitch/GPS receiver point will determine if the number is entered as positive (+) or negative (-).

To enter an Implement Offset:

1. From the Control Setup screen, press the **Link Offset** button.

CALCULATING IMPLEMENT OFFSET

Implement Offset is the distance from the center of a control channel to the hitch connection or GPS receiver point.

From behind the implement facing tractor:

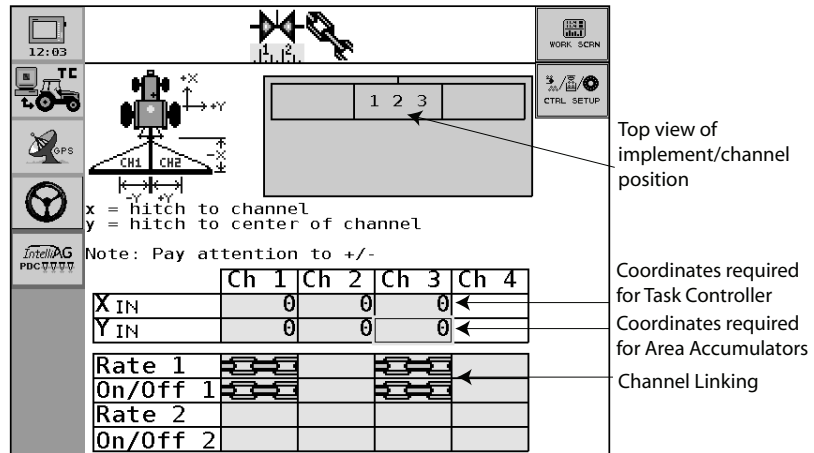
- Channels to the left of the hitch/GPS receiver point (negative entry) (-y)
- Channels to the right of the hitch/GPS receiver point (positive entry) (+y)





Figure 94

Implement Offset and Channel Linking screen



CHANNEL LINKING

Channel Linking allows control channels to be linked together so that rates can be increased or decreased simultaneously and turned on or off at the Main Work screen.

To Link Channels:

1. At the Control Channel table, press the Channel input box and select the linking symbol for the channels to be linked together.

(Figure 94) depicts channels 1 and 3 linked together to control rates and turn the Channels on and off simultaneously.

MATERIAL APPLICATION RATES

The **Material Rate** button resets a system to IntelliAg rates that has been running a task under Task Controller map control. An SD Card graphic icon on the IntelliAg Work screen indicates this condition. The **Material Rate** button appears on the IntelliAg Work screen to select current rates or to reload IntelliAg rates.

The **Material Rate** button only appears if a task is stopped in Task Controller and:

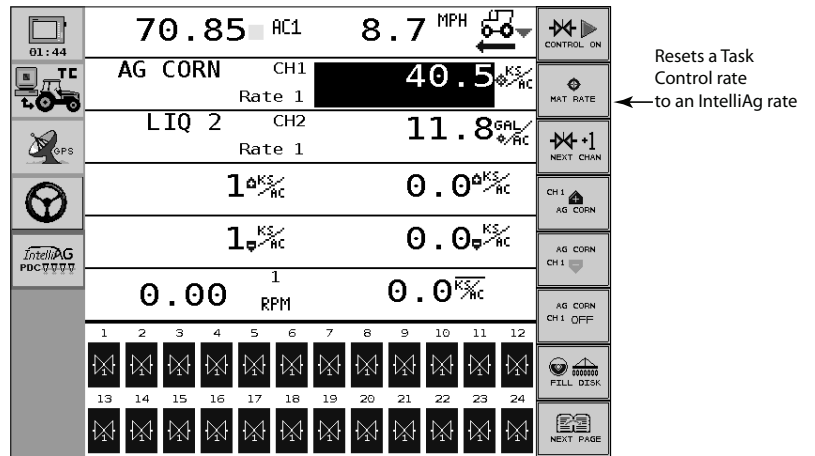
- ground speed is greater than 0
- the implement lift switch is down (operate mode)
- the master switch in ON for 5 seconds





Figure 95

Material Rate Screen

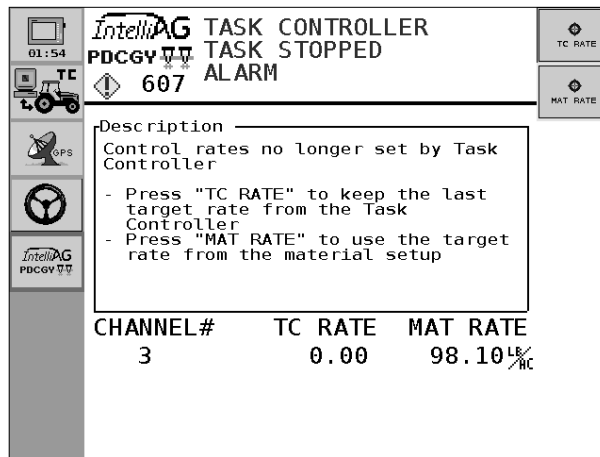


If a Task Controller alarm occurs:

- Press the **TC Rate** button to continue to run a task at the Task Controller rate
- Press the **Material Rate** button to reset the system to IntelliAg rates

Figure 96

Task Controller Alarm



IMPORT/EXPORT DATA

Implement configurations stored on the Working Set Master (WSMT) can be exported to an SD card for transfer to other machines. This file transfer eliminates manual entry of all settings to similar machines.

Only configurations created from the Virtual Terminal can be imported and exported; no configurations created from a PC will transfer.

IMPORTANT: Import/export does NOT save ECU or other Task Controller functions.



To transfer WSMT configurations:

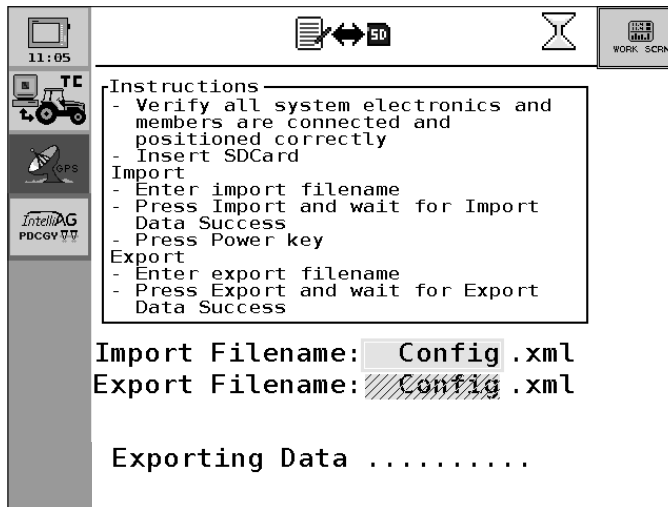
1. Verify an SD card is inserted into the VT and all system electronics and members are connected properly and configured correctly.
2. From the IntelliAg Main Work screen, press the **Next Page** button to access the **Config** button.

EXPORT DATA

1. Press the Export Data input box and enter a file name. File name is case sensitive and must be exact for the import function to appear.
2. The new data file name will appear in the input box and be saved as an .xml file extension.
3. Press the **Export** button.
As files are saved, an hour glass will flash at the top of the screen and "Exporting Data...." will appear at screen bottom. A successful data transfer will appear when complete.
4. The **Import** button will appear after a successful transfer.

Figure 97

Export Data Screen



IMPORT DATA

1. Insert SD card into another Virtual Terminal.
2. Verify all modules and sensors are connected properly and modules are positioned correctly.
3. At the Import/Export Data screen enter the Import File name to transfer. File name is case sensitive and must be exact for the import function to appear.
4. Press the **Import** button.
As files are transferring, an hour glass will flash and "Import Data Validation" will appear at screen bottom.
5. Press the **Power** button to reboot the IntelliAg WSMT.

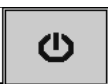
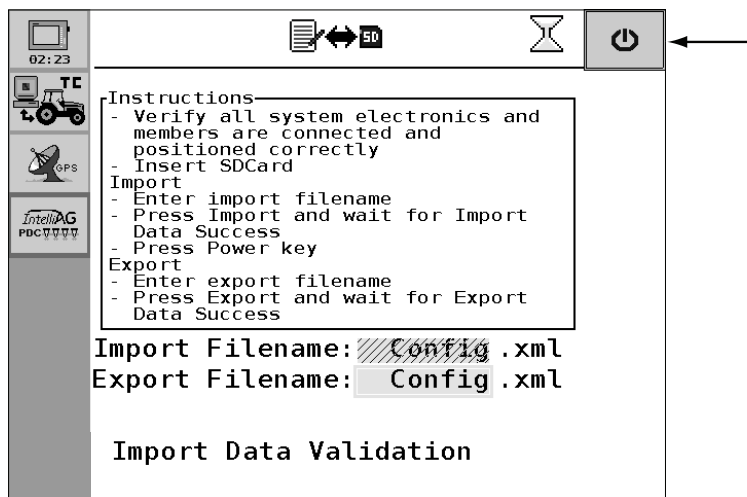




Figure 98

Import Data Validation Screen



OPERATOR'S MANUAL





TROUBLESHOOTING & ALARMS



Alarms are indicated on the Virtual Terminal with the following graphic, as well as with a continuous, audible alarm. The audible alarm is terminated by pressing the **Alarm Cancel** button or **ESC** key. In addition, detailed descriptions of the current alarm can be viewed by pressing the **Alarm Detail** button. Some of the alarm conditions display instructions on correcting the situation.

IntelliAG



Alarms are presented in a full screen display that will describe the alarm and, depending upon the alarm, may give instructions on how to fix the alarm. Each alarm type has an associated alarm number that can be cross-referenced in this section.

Some alarms (for instance a Master Switch alarm) will require a specific action before the alarm condition will cease. In these cases, the instructions to proceed are indicated in the alarm display.

The following table describes the possible alarm conditions, causes, and remedies.



OPERATOR'S MANUAL



ALARM #	ALARM	PROBABLE CAUSE	CORRECTIVE ACTION
1	Software Task Stack Overflow Alarm	1. Internal system software error.	1. Cycle system power OFF/ON. If condition persists, contact DICKEY-john Technical Support (1-800-637-3302) or DICKEY-john Europe (011-33-141-192189).
2	Software System Stack Overflow Alarm	1. Internal system software error.	1. Cycle system power OFF/ON. If condition persists, contact DICKEY-john Technical Support (1-800-637-3302) or DICKEY-john Europe (011-33-141-192189).
3	VT Out of Memory Alarm	THE ECU MEMORY REQUIREMENTS ARE GREATER THAN THE VIRTUAL TERMINAL CAN HANDLE.	1. Remove any unnecessary ECU's 2. Contact DICKEY-john Technical Support (1-800-637-3302) or DICKEY-john Europe (011-33-141-192189) for updated hardware.
4	Software Version Does Not Support this Configuration Alarm	1. Occurs if new software is loaded and does not support the configuration of the hardware it is loaded on.	1. Record software and model information listed below. 2. Contact dealer for software update.
202	Ground Speed Failure Alarm	ONLY ACTIVE IN PLANTER MONITOR MODE. SEEDS ARE DETECTED WHEN THERE IS NO GROUND SPEED. 1. Incorrect speed source setting or calibration. 2. Defective speed sensor or harness. 3. Defective module or virtual terminal.	1. Verify correct speed source setting and speed calibration on the Ground Speed Calibration screen. 2. Inspect speed sensor/harness for damage or replace speed sensor. 3. Replace module or virtual terminal.
203	Continuous Test Failure Alarm	CONTROL CONDITIONS EXCEED THE DISK RPM LIMITS. 1. Test speed setting is set too high or low. 2. Disk Hi and/or Disk Low settings are incorrect.	1. Enter an appropriate Test Speed. 2. Verify or enter appropriate Disk Hi and/or Disk Low values.
204	5 Revolution Test Failure Alarm	CONTROL CONDITIONS EXCEED THE DISK RPM LIMITS. 1. Test Speed setting is set too high or low. 2. Disk Hi and/or Disk Low settings are incorrect.	1. Enter an appropriate test speed. 2. Verify or enter appropriate Disk Hi and/or Disk Low values.
205	Channel Failure Alarm	1. Defective control valve. 2. Defective feedback sensor. 3. Defective module harness or module harness fuse. 4. Defective module.	1. Inspect control valve for damage or replace. 2. Inspect feedback sensor for damage or replace. 3. Inspect module harness for damage. Replace harness fuse. 4. Inspect module for damage or replace.
206	Channel Unable to Control Alarm	1. Incorrect channel settings. 2. Incorrect feedback sensor installation. 3. Defective feedback sensor.	1. Verify correct setup constants on the Channel Configuration screen. Perform a valve calibration. 2. Verify correct installation of the feedback sensor. 3. Inspect feedback sensor for damage or replace.

OPERATOR'S MANUAL



ALARM #	ALARM	PROBABLE CAUSE	CORRECTIVE ACTION
207	Channel Unstable Alarm	<ol style="list-style-type: none"> 1. Incorrect channel settings. 2. Incorrect feedback sensor installation. 3. Defective feedback sensor. 	<ol style="list-style-type: none"> 1. Verify correct setup constants on the Channel Configuration screen. Perform a valve calibration. 2. Verify correct installation of the feedback sensor. 3. Inspect feedback sensor for damage or replace.
208	Channel Saturation Exceeded Alarm	<ol style="list-style-type: none"> 1. Excessive speed. 2. Incorrect channel settings. Desired rate too high for implement. 3. Target rate too high 	<ol style="list-style-type: none"> 1. Reduce speed. 2. Verify correct setup constants on the Channel Configuration screen. Perform a valve calibration and a Calibration constant. 3. Reduce target rate.
209	Channel High Limit Exceeded Alarm	CONTROL LIMITED BY HIGH LIMIT. UNDER APPLICATION IS OCCURRING. NOTE: System will not run faster than High Limit Value.	<ol style="list-style-type: none"> 1. Check and/or reduce speed. 2. Verify Channel setup (high RPM) 3. Perform new valve calibration. 4. Check and/or reduce target rate. 5. Inspect feedback sensor for damage. 6. Inspect control valve for damage. 7. Inspect harness/module for damage. 8. Decrease target rate.
210	Channel Low Limit Exceeded Alarm	CONTROL RATE LIMITED BY LOW LIMIT. OVER APPLICATION IS OCCURRING.	<ol style="list-style-type: none"> 1. Increase speed. 2. Verify correct setup constants (low RPM). 3. Perform valve calibration. 4. Increase target rate.
211	All Rows Failed Alarm	<ol style="list-style-type: none"> 1. Seed meter drive malfunction. 2. Rows are not assigned to channel and channels are turned off. 	<ol style="list-style-type: none"> 1. Check seeding drive(s). 2. Assign rows to channel.
212	Row Failure Alarm	<p>SEED RATE HAS FALLEN BELOW THE ROW FAIL RATE SETTING ON THE SEED MONITOR SETUP SCREEN.</p> <ol style="list-style-type: none"> 1. Seed meter malfunction. 2. Dirty or defective seed sensor. 3. Damaged planter harness. 4. Defective module harness or module 5. Out of seed 	<ol style="list-style-type: none"> 1. Verify proper planter operation. 2. Inspect seed sensor for dirt or damage. Replace if necessary. 3. Inspect planter harness for damage. Repair or replace. 4. Inspect harness and module for damage. Replace if necessary. 5. Fill with seed
213	High Population Limit Exceeded Alarm	<p>SEED RATE HAS EXCEEDED THE HIGH ALARM SETTING ON THE SEED MONITOR SETUP SCREEN.</p> <ol style="list-style-type: none"> 1. Seed meter malfunction or incorrect setup. 2. Defective seed sensor. 3. Defective module. 	<ol style="list-style-type: none"> 1. Verify proper planter options/setup. 2. Inspect seed sensor for damage. Replace if necessary. 3. Inspect module for damage. Replace if necessary.
214	Low Population Limit Exceeded Alarm	<p>SEED RATE HAS DROPPED BELOW THE LOW ALARM SETTING ON THE SEED MONITOR SETUP SCREEN.</p> <ol style="list-style-type: none"> 1. Seed meter malfunction or incorrect setup. 2. Defective seed sensor. 3. Defective module. 4. Running out of seed. 	<ol style="list-style-type: none"> 1. Verify proper planter operation/setup. 2. Inspect seed sensor for damage. Replace if necessary. 3. Inspect module for damage. Replace if necessary. 4. Fill with seed.

OPERATOR'S MANUAL



ALARM #	ALARM	PROBABLE CAUSE	CORRECTIVE ACTION
215	High Pressure Limit Exceeded Alarm	<p>SENSED PRESSURE EXCEEDS THE HIGH ALARM SETTING ON THE PRESSURE SETUP SCREEN.</p> <ol style="list-style-type: none"> 1. Implement malfunction or incorrect setup. 2. Defective pressure sensor. 3. Defective module. 	<ol style="list-style-type: none"> 1. Verify proper implement operation/setup. 2. Inspect pressure sensor for damage. Replace if necessary. 3. Inspect module for damage. Replace if necessary.
216	Low Pressure Limit Exceeded Alarm	<p>SENSED PRESSURE BELOW THE LOW ALARM SETTING ON THE PRESSURE SETUP SCREEN.</p> <ol style="list-style-type: none"> 1. Implement malfunction or incorrect setup. 2. Defective pressure sensor. 3. Defective module harness or module. 	<ol style="list-style-type: none"> 1. Verify proper implement operation/setup. 2. Inspect pressure sensor for damage. Replace if necessary. 3. Inspect module and/or module harness for damage. Replace if necessary.
217	Member module Detection Alarm	<p>NUMBER OF MEMBER MODULES DOES NOT MATCH THE SYSTEM CONFIGURATION.</p> <ol style="list-style-type: none"> 1. Too few modules connect to system. 2. Too many modules connected to system. 3. Defective CAN/module harness. 4. Blown module harness fuse. 5. Defective module. 6. New module has been added to system. 	<ol style="list-style-type: none"> 1. Verify correct module configuration setup on the Module Configuration screen. 2. Verify correct module configuration setup on the Module Configuration screen. 3. Identify missing module in the Module Configuration list. Inspect CAN/module harness of the missing module for damage. Repair or replace harness. 4. Inspect module harness fuse of the identified module. Replace if necessary. 5. Identify missing module in the Module Configuration list. Inspect missing module for damage or replace. 6. Verify correct module configuration setup on the Module Configuration screen.
218	Pressure Sensor Detection Alarm	<p>NUMBER OF PRESSURE SENSORS CONNECTED DOES NOT AGREE WITH THE NUMBER OF SENSORS CONFIGURED ON THE PRESSURE SENSOR CONFIGURATION SCREEN.</p> <ol style="list-style-type: none"> 1. Defective Sensor. 2. Defective module or damaged module harness. 3. Additional pressure sensor detected. 	<ol style="list-style-type: none"> 1. Inspect pressure sensor for damage or replace. 2. Inspect module and/or module harness for damage. Replace if necessary. 3. Verify correct# ACC setting for each module.
219	Row Sensor Detection Alarm	<p>NUMBER OF SEED SENSORS CONNECTED DOES NOT AGREE WITH THE NUMBER OF SENSORS CONFIGURED ON THE SEED SENSOR CONFIGURATION SCREEN.</p> <ol style="list-style-type: none"> 1. Defective seed sensor. 2. Defective module or damaged module harness. 3. Additional seed sensor detected. 	<ol style="list-style-type: none"> 1. Inspect seed sensor for damage or replace. 2. Inspect module and/or module harness for damage. Replace if necessary. 3. Verify correct # ROWS setting for each module.

OPERATOR'S MANUAL



ALARM #	ALARM	PROBABLE CAUSE	CORRECTIVE ACTION
220	Row Sensors Installed Incorrectly Alarm	<p>ROWS ARE NOT DETECTED SEQUENTIALLY ON A MODULE.</p> <ol style="list-style-type: none"> 1. Incorrect seed row connections. 2. Defective seed sensor. 3. Defective module or damaged module harness. 	<ol style="list-style-type: none"> 1. Verify seed sensors are connected sequentially on all modules as instructed in installation. 2. Inspect seed sensor for damage or replace. 3. Inspect module and/or module harness for damage. Replace if necessary.
221	Channel Invalid State Alarm	<ol style="list-style-type: none"> 1. Internal system software error. 	<ol style="list-style-type: none"> 1. Cycle system power Off/On. If condition persists, contact DICKEY-john Technical Support (1-800-637-3302) or DICKEY-john Europe (011-22-141-192189).
222	Channel Setup Height Error Alarm	<ol style="list-style-type: none"> 1. Implement hydraulic system malfunction. 2. Defective control valve. 3. Incorrect feedback sensor installation. 4. Defective feedback sensor. 5. Limit Max Output set too low. 	<ol style="list-style-type: none"> 1. Verify implement hydraulic system operation. 2. Inspect control valve for damage. Replace if necessary. 3. Verify correct installation of the feedback sensor. 4. Inspect feedback sensor for damage or replace. 5. Set Limit Max Output to a higher PWM% on the Valve Calibration screen. Perform a new valve calibration.
223	Channel Max Feedback Unreachable Alarm	<ol style="list-style-type: none"> 1. Limit Max Output set too low. 2. Incorrect feedback sensor installation. 3. Defective feedback sensor. 	<ol style="list-style-type: none"> 1. Set Limit Max Output to a higher level on the Valve Calibration screen. Perform a new valve calibration. 2. Verify correct installation of the feedback sensor. 3. Inspect feedback sensor for damage or replace.
224	No Channel Gain Steps Calculated Alarm	<ol style="list-style-type: none"> 1. Implement hydraulic system malfunction. 2. Defective control valve. 3. Incorrect feedback sensor installation. 4. Defective feedback sensor. 	<ol style="list-style-type: none"> 1. Verify implement hydraulic system operation. 2. Inspect control valve for damage. Replace if necessary. 3. Verify correct installation of the feedback sensor. 4. Inspect feedback sensor for damage or replace.
225	Hopper Sensor Low Alarm	<ol style="list-style-type: none"> 1. Incorrect logic level setting on the Hopper Setup screen. 2. Dirty or defective hopper sensor. 3. Defective module harness or module 4. Hopper empty 	<ol style="list-style-type: none"> 1. Verify correct logic level setting on the Hopper Setup screen. 2. Clean/inspect hopper sensor. Replace if necessary. 3. Inspect harness and module for damage. Replace if necessary. 4. Fill hopper.
226	RPM Sensor High Limit Exceeded Alarm	<p>SENSED RPM EXCEEDS THE HIGH ALARM SETTING ON THE RPM SETUP SCREEN.</p> <ol style="list-style-type: none"> 1. Implement malfunction or incorrect setup. 2. Defective RPM sensor. 3. Defective module. 	<ol style="list-style-type: none"> 1. Verify proper implement operation/setup. 2. Inspect RPM sensor for damage. Replace if necessary. 3. Inspect module for damage. Replace if necessary.

OPERATOR'S MANUAL



ALARM #	ALARM	PROBABLE CAUSE	CORRECTIVE ACTION
227	RPM Sensor Low Limit Exceeded Alarm	<p>SENSED RPM BELOW THE LOW ALARM SETTING ON THE RPM SETUP SCREEN.</p> <ol style="list-style-type: none"> 1. Implement malfunction or incorrect setup. 2. Defective RPM sensor. 3. Defective module harness or module. 	<ol style="list-style-type: none"> 1. Verify proper implement operation/setup. 2. Inspect RPM sensor for damage. Replace if necessary. 3. Inspect module for damage. Replace if necessary.
228	Hopper Sensor Detection Alarm	<p>NUMBER OF HOPPER SENSORS CONNECTED DOES NOT AGREE WITH THE NUMBER OF SENSORS CONFIGURED ON THE HOPPER SENSOR CONFIGURATION SCREEN.</p> <ol style="list-style-type: none"> 1. Defective hopper sensor. 2. Defective module or damaged module harness. 3. Additional hopper sensors detected. 	<ol style="list-style-type: none"> 1. Inspect hopper sensor for damage or replace. 2. Inspect module and/or module harness for damage. Replace if necessary. 3. Verify correct # HOPP setting for each module.
229	Hopper Sensors Installed Incorrectly Alarm	<p>HOPPER SENSORS ARE NOT INSTALLED SEQUENTIALLY ON A MODULE.</p> <ol style="list-style-type: none"> 1. Incorrect hopper sensor connections. 2. Defective hopper sensor. 3. Defective module or damaged module harness. 	<ol style="list-style-type: none"> 1. Verify hopper sensors are connected sequentially on all modules as instructed in INSTALLATION. 2. Inspect hopper sensor for damage or replace. 3. Inspect module and/or module harness for damage. Replace if necessary.
230	Pressure Sensors Installed Incorrectly Alarm	<p>PRESSURE SENSORS ARE NOT INSTALLED SEQUENTIALLY ON A MODULE.</p> <ol style="list-style-type: none"> 1. Incorrect pressure sensor connections. 2. Defective pressure sensor. 3. Defective module or damaged module harness. 	<ol style="list-style-type: none"> 1. Verify pressure sensors are connected sequentially on all modules as instructed in INSTALLATION. 2. Inspect pressure sensor for damage or replace. 3. Inspect module and/or module harness for damage. Replace if necessary.
231	Seeding Detected on a Tramlined Row Alarm	<p>Occurs if a tramlined row does not shut off the row unit and seeds continue to be detected. (Only possible if system supports tramlining).</p> <ol style="list-style-type: none"> 1. Output to row mapping is assigned incorrectly. 2. Seed sensor malfunction. 	<ol style="list-style-type: none"> 1. Check output row mapping. 2. Check seed sensor to ensure no false triggering. 3. Inspect and verify Tramline output is shutting off seeds correctly.
232	RPM Sensor Low Limit Exceeded With Control Channel Shutdown Alarm	<p>RPM HAS DROPPED BELOW THE DISABLE CONTROL ON LOW ALARM SETTING ON THE ACCESSORY SETUP SCREEN.</p> <ol style="list-style-type: none"> 1. Defective RPM sensor. 2. Damaged module harness. 3. Defective module. 4. Low RPM 	<ol style="list-style-type: none"> 1. Inspect RPM sensor for damage. Replace if necessary. 2. Inspect module harness for damage. Repair or replace. 3. Inspect module for damage. Replace if necessary. 4. Increase RPM.

OPERATOR'S MANUAL



ALARM #	ALARM	PROBABLE CAUSE	CORRECTIVE ACTION
233	Channel Activation Alarm	CHANNEL DELAY OR PRECHARGE IS ENABLED. DURING THIS THE CONTROL WILL RUN WITHOUT GROUND SPEED OR WITHOUT THE IMPLEMENT DOWN.	<ol style="list-style-type: none"> 1. Acknowledge alarm to activate control channels. 2. Acknowledge alarm and disable Delay or Precharge to stop control.
235	New Member Module Detected Alarm	1. New member module has been found.	1. Assign sensors to the new module at the Module Configuration Setup screen and its position.
236	Intermittent Member Module Detected Alarm	1. A member module that had previously failed communication has come online.	1. Inspect harness connections to this module.
237	Product Level Low Alarm	1. Calculated product level has dropped below alarm level.	1. Fill product bin and reset level.
240	Seeding Detected on a Control Off Row Alarm	1. Channel turned off and seed continues to be detected.	1. Check seed dispensing unit for proper shut off.
241	Control Not Active With Implement Lowered and Speed	1. Control will not operate while on a setup screen.	<ol style="list-style-type: none"> 1. Navigate to the Work Screen to activate the control. 2. Raise implement and stop forward speed to clear alarm.
246	Master Switch Softkey Press Alarm	1. Warning of action associated with keypress.	1. Press Control Start key to activate control.
249	Control Channel Activation Alarm	1. Controls will run without ground speed or without implement lowered. Channel Manual Mode or Precharge is enabled. During this the control will run without ground speed or without the implement down.	<ol style="list-style-type: none"> 1. Acknowledge alarm to activate control channels. 2. Acknowledge alarm and disable manual or precharge to stop control.
251	New Hardware Detected Alarm	1. New hardware detected that requires system to be rebooted to acknowledge hardware.	1. Cycle system power to complete hardware install.
253	Monitor Channel High Limit Exceeded Alarm	<ol style="list-style-type: none"> 1. High limit set incorrectly. 2. Transmission not set correctly. 	<ol style="list-style-type: none"> 1. Verify high limit. 2. Verify transmission setting.
254	Monitor Channel Low Limit Exceeded Alarm	<ol style="list-style-type: none"> 1. Low limit set incorrectly. 2. Transmission not set correctly. 	<ol style="list-style-type: none"> 1. Verify low limit. 2. Verify transmission setting.
255	Channel Invalid Material Alarm	1. There is no material defined with a type that matches the selected control channel type.	1. Create a material with the channel type.
260	Control Channel Failure Alarm	1. Control channel is not responding.	<ol style="list-style-type: none"> 1. Cycle Master Switch or implement switch to restart the control channel. 2. Verify drive is connected and engaged. 3. Check feedback sensor for damage. 4. Check harness for damage. 5. Check module for damage.
261	Control Channel Unable to Control Alarm	1. Control Channel cannot control to the specified rate.	<ol style="list-style-type: none"> 1. Inspect control channel setup. 2. Perform new valve calibration. 3. Check feedback sensor for damage. 4. Check control valve for damage. 5. Check harness for damage. 6. Check module for damage.
262	RPM Control Channel is off Alarm	1. RPM Channels are off. System may not operate properly.	<ol style="list-style-type: none"> 1. Acknowledge alarm to leave RPM control channels off. 2. Press "CHAN ON" to turn all RPM channels on.

OPERATOR'S MANUAL



ALARM #	ALARM	PROBABLE CAUSE	CORRECTIVE ACTION
264	Ground speed Calibration Configuration Alarm	Current ground speed calibration exceeds the max number of ground speed pulses of 50000 that can be entered as a ground speed constant.	<ol style="list-style-type: none"> 1. Probable that the marked off course limits were exceeded. Verify course length of 400 ft (100m). 2. Ground speed sensor has too high resolution of pulses. Check speed sensor for damage.
602	8 Volt Supply Failure Alarm	<p>8V SUPPLY VOLTAGE IS BELOW 7.2V OR HIGHER THAN 16V.</p> <ol style="list-style-type: none"> 1. Damaged module harness. 2. Defective seed or hopper sensor. 3. Defective module. 	<ol style="list-style-type: none"> 1. Inspect module harness for damage. Repair or replace harness. 2. Inspect seed or hopper sensors connected to the identified module for damage. Replace sensors if necessary. 3. Replace identified module.
603	Member Module Communication Failed Alarm	<p>COMMUNICATION WITH AN ACTIVE MODULE HAS FAILED</p> <ol style="list-style-type: none"> 1. Damaged CAN or module harness. 2. Blown module harness fuse. 3. Defective module. 	<ol style="list-style-type: none"> 1. Identify missing module in the Module Configuration list. Inspect CAN/module harness of the missing module for damage. Repair or replace harness. 2. Inspect module harness fuse, replace if necessary. 3. Identify missing module in the Module Configuration list. Inspect missing module for damage or replace.
604	ECU Voltage Out of Range Alarm	<p>ECU VOLTAGE IS BELOW 11V OR HIGHER THAN 16V.</p> <ol style="list-style-type: none"> 1. Damaged CAN or module harness. 2. Defective module 	<ol style="list-style-type: none"> 1. Inspect CAN/module harness of the identified module for damage. 2. Inspect identified module for damage or replace.
605	Solenoid Voltage Out of Range Alarm	<p>SOLENOID VOLTAGE IS BELOW 11V OR HIGHER THAN 16V.</p> <ol style="list-style-type: none"> 1. Damaged CAN or module harness. 2. Blown module harness fuse. 3. Defective module. 	<ol style="list-style-type: none"> 1. Inspect CAN/module harness of the identified module for damage. Repair or replace harness. 2. Inspect module harness fuse or replace. 3. Inspect identified module for damage or replace.
606	Ground Offset Voltage Out of Range Alarm	<ol style="list-style-type: none"> 1. Damaged/shorted Actuator Harness. 2. Defective PWM valve driver or Servo valve driver. 3. Defective module. 	<ol style="list-style-type: none"> 1. Inspect Actuator Harness for damage around the WPM and Servo valve connections. Repair or replace harness. 2. Inspect PWM or Servo valve drivers for damage and replace if necessary. 3. Inspect identified module for damage and replace if necessary.
607	Task Controller Task Stopped Alarm	<ol style="list-style-type: none"> 1. Control rates no longer set by Task Controller. 	<ol style="list-style-type: none"> 1. Press TC RATE to keep the last target rate from the Task Controller. 2. Press MAT RATE to use the target rate from the material setup.
608	Task Controller Data Logging Error	<ol style="list-style-type: none"> 1. Task Controller is setting target rates without logging the data. 	<ol style="list-style-type: none"> 1. Restart Task Controller task. 2. Cycle power to entire system.





APPENDIX

SYSTEM CONFIGURATION WORKSHEET - MODULE SETUP

Module Type	Module Address	# of Rows	Row #	# of Hoppers	Hopper #	# of RPM	RPM #
	1	2	3	4			
Hopper Configuration							
Logic Level							
Alarm Delay							
RPM Configuration	1	2	3				
High Alarm							
Low Alarm							
High Alarm Delay							
Low Alarm Delay							
Constant							
Disable Control Low Alarm							
Pressure Configuration	1	2	3	4			
High Alarm							
Low Alarm							
High Alarm Delay							
Low Alarm Delay							
Pressure Filter							

OPERATOR'S MANUAL



SYSTEM CONFIGURATION WORKSHEET - CHANNEL CONFIGURATION

Channel Configuration	1	2	3	4
Type				
Material Name				
Control Mode				
Drive Type				
Drive Frequency				
Input Filter				
Gear Ratio				
Sensor Constant				
K-Factor				
# of Seed Rows				
Seed Rows				
Channel Width				
Precharge(+) Delay (-)				
Valve Locking				
Flush Enabled				
Seed Monitor Configuration		Row Configuration		
Target Rate		Row Width		
High Alarm		Auto Update Width		
Low Alarm		Imp Width		
High Alarm Delay		On/Off Pattern		
Low Alarm Delay		Pop/Block Pattern		
Population Adjust				
Population Filter				
Row Fail Rate				
Ground Speed Configuration				
Source				
Manual Speed				
Ground Speed Constant				
Shutoff Speed				
Minimum Override				
Master Sw Timeout				
Ground Speed Fail Alarm Delay				
Implement Lift				
Precharge Speed				
Flush Speed				



SYSTEM CONFIGURATION WORKSHEET - WORK SCREEN

Work Screen 1

Large Bargraphs	

Work Screen 2

Work Screen 3

OPERATOR'S MANUAL



WORK SCREEN WORKSHEET - MATERIAL SETUP (INC/DEC)

	1	2	3	4	5	6	7	8
Material Name								
Type								
Units								
Preset Method								
Target Rate								
Max Rate								
Min Rate								
Inc/Dec %								
Seeds Per Rev								
Density								
Spreader Constant								
Seeds per pound								
Low Limit								
High Limit								
Low Pop Alarm								
High Pop Alarm								
Product Level Alarm								

	9	10	11	12	13	14	15	16
Material Name								
Type								
Units								
Preset Method								
Target Rate								
Max Rate								
Min Rate								
Inc/Dec %								
Seeds Per Rev								
Density								
Spreader Constant								
Seeds per pound								
Low Limit								
High Limit								
Low Pop Alarm								
High Pop Alarm								
Product Level Alarm								

OPERATOR'S MANUAL



WORK SCREEN WORKSHEET - MATERIAL SETUP (PRESET)

Type									
Units									
Preset Method									
Rate 1									
Rate 2									
Rate 3									
Rate 4									
Rate 5									
Rate 6									
Rate 7									
Rate 8									
Rate 9									
Rate 10									
Seeds Per Rev									
Density									
Spreader Constant									
Seeds per pound									
Low Limit									
High Limit									
Low Pop Alarm									
High Pop Alarm									
Product Level Alarm									

	9	10	11	12	13	14	15	16
Material Name								
Type								
Units								
Preset Method								
Rate 1								
Rate 2								
Rate 3								
Rate 4								
Rate 5								
Rate 6								
Rate 7								
Rate 8								
Rate 9								
Rate 10								
Seeds Per Rev								
Density								
Spreader Constant								
Seeds per pound								
Low Limit								
High Limit								
Low Pop Alarm								
High Pop Alarm								
Product Level Alarm								



Dealers have the responsibility of calling to the attention of their customers the following warranty prior to acceptance of an order from their customer for any DICKEY-john product.

DICKEY-john® WARRANTY

DICKEY-john warrants to the original purchaser for use that, if any part of the product proves to be defective in material or workmanship within one year from date of original installation, and is returned to DICKEY-john within 30 days after such defect is discovered, DICKEY-john will (at our option) either replace or repair said part. This warranty does not apply to damage resulting from misuse, neglect, accident, or improper installation or maintenance; any expenses or liability for repairs made by outside parties without DICKEY-john's written consent; damage to any associated equipment; or lost profits or special damages. Said part will not be considered defective if it substantially fulfills the performance expectations. THE FOREGOING WARRANTY IS EXCLUSIVE AND IN LIEU OF ALL OTHER WARRANTIES OF MERCHANTABILITY, FITNESS FOR PURPOSE, AND OF ANY OTHER TYPE, WHETHER EXPRESS OR IMPLIED. DICKEY-john neither assumes nor authorizes anyone to assume for it any other obligation or liability in connection with said part and will not be liable for consequential damages. Purchaser accepts these terms and warranty limitations unless the product is returned within fifteen days for full refund of purchase price.

**For DICKEY-john Service Department, call
1-800-637-3302 in either the U.S.A. or Canada**



Headquarters:

5200 Dickey-john Road, Auburn, IL USA 62615

TEL: 217 438 3371, FAX: 217 438 6012, WEB: www.dickey-john.com

Europe:

DICKEY-john Europe S.A.S, 165, boulevard de Valmy, 92706 – Colombes – France

TEL: 33 (0) 1 41 19 21 80, FAX: 33 (0) 1 47 86 00 07 WEB: www.dickey-john.eu