



Safety Notices	1
System Overview	3
Features	3
System Requirements	3
Daisy Chain Sensors	4
Daisy Chain Module(s)	4
Daisy Chain Module Harnesses 1 and 2 Loop	4
Module Extension Harnesses	5
Harness Loop A/B	5
CAN Bus Adapter Harness	6
Lift Switch/Master Switch Adapter Kit	6
CAN Terminator	6
System Components	7
ISO Compatible Virtual Terminal	7
Hardware Installation	9
Attach Module To Implement	9
Assemble Lift Switch Connector	11
Connecting Sensors on Loop	14
Connecting Harnesses	15
System Layout Examples	16
Single Module with One Loop	16
Multi Modules and Loops	17
Initial Powerup	19
Initial Setup	20
Loop Setup Screen Functions	22
Loop Setup Buttons	23
System Operating States	24
Not Ready State	24
Ready State	24
Run State	24
Failed State	24
Daisy Chain System Operation	25
Message Center Screen	25
Loop Setup	27
System Tests	28
Communication Test	28
Communication Sensor Legend	29
Power Test	30
Power Legend	30
Sensor Test	31
Sensor Legend	32
System Summary	33
Tramline Setup	35
Setup	35
Input Type	35
Input State (Hi/Lo)	36
Assigning Sensors	36
Auxiliary Power	36
Changing the Language	38



Module Diagnostics **39**
 Diagnostics Screen 1 39
 Diagnostics Screen 2 40
 Diagnostics Screen 3 41

Alarms **43**



SAFETY NOTICES

Safety notices are one of the primary ways to call attention to potential hazards. An absence of specific alerts does not mean that there are no safety risks involved.



This Safety Alert Symbol identifies important safety messages in this manual. When you see this symbol, carefully read the message that follows. Be alert to the possibility of personal injury or death.

⚠ WARNING

Use of the word **WARNING** indicates a potentially hazardous situation which, if not avoided, could result in death or serious injury.

⚠ CAUTION

Use of the word **CAUTION** with the Safety Alert Symbol indicates a potentially hazardous situation which, if not avoided, may result in minor or moderate injury.

CAUTION

Use of the word **CAUTION** without the safety alert symbol indicates a potentially hazardous situation which, if not avoided, may result in equipment damage.

OPERATOR'S MANUAL





SYSTEM OVERVIEW

The DICKEY-john Daisy Chain blockage detection system monitors seed and fertilizer flow on air seeder applications to determine if distribution hoses are open or blocked. All of the devices communicate using the ISO 11783 CAN communications standard.

FEATURES

- System can monitor up to 4 modules and a total of 8 loops.
- Each module can interface with a maximum of 2 sensor loops.
- Maximum number of sensors per loop is 54 for a total of 432 total sensors (minimum of 2 sensors per loop)
- Tramline monitoring of seed or fertilizer with up to 192 sensors assigned to tramlining
- Full screen alarms pinpoint blockage or system issues for quick resolution
- Two-way communication lines between sensors and modules
- System can continue to monitor sensor blockage with 1 line failure
- 3 system tests (communication, power, and sensor) provide immediate feedback of system status
- Additional rows and blockage sensors can be added later to this system with minimal harnessing changes
- Russian language available

SYSTEM REQUIREMENTS

The minimum requirements to operate the Daisy Chain blockage system consist of the following components:

- Daisy Chain sensors
- Daisy Chain module(s)
- Daisy Chain module harnesses
- ISO CAN bus adapter harness
- Module extension harnesses
- Harness loop A/B connector
- CAN terminator
- ISO-compatible virtual terminal
- Lift switch/master switch
- Lift switch adapter kit
- Tramline connector kit (for tramlining functionality)

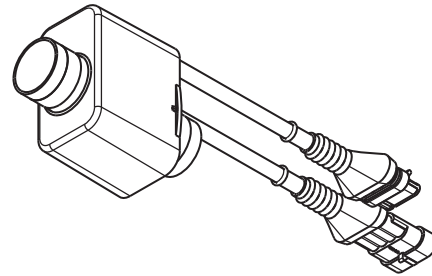


DAISY CHAIN SENSORS

Sensors monitor seed and fertilizer flow connected to distribution hoses and detects blockage. Sensors are connected to each other in a serial chain layout contained within the loop.

Figure 1

Daisy Chain Sensor

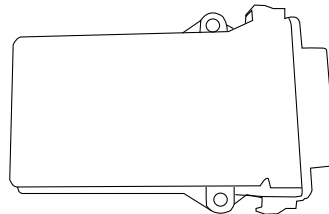


DAISY CHAIN MODULE(S)

Up to 2 loops per module, a maximum of 4 modules and 8 loops, connect to sensors to communicate blockage and system status for display on the virtual terminal.

Figure 2

Module



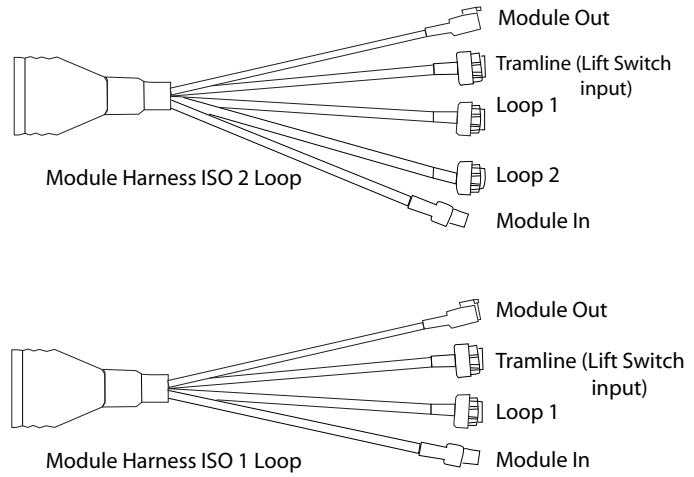
DAISY CHAIN MODULE HARNESSES 1 AND 2 LOOP

Two harness styles (1 or 2 loop) are available based on how many loops are connected to the module.

A 2-loop harness is required for applications using more than 54 sensors or to accommodate 2 towers with 2 loops on one module.



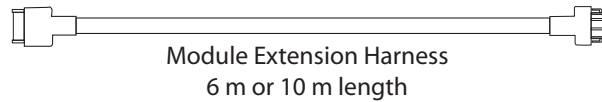
Figure 3
Module Harnesses



MODULE EXTENSION HARNESSES

Module extension harnesses (6 or 10 meter) are optional that connect Loop 2 of the Module Harness Loop connector and the Loop 2 A/B connector harness.

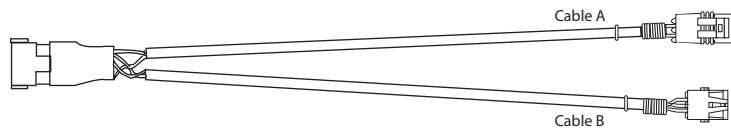
Figure 4
Module Extension Harness



HARNESS LOOP A/B

Harness Loop A/B attaches the module harness to the first and last sensors on the loop.

Figure 5
Harness Loop A/B



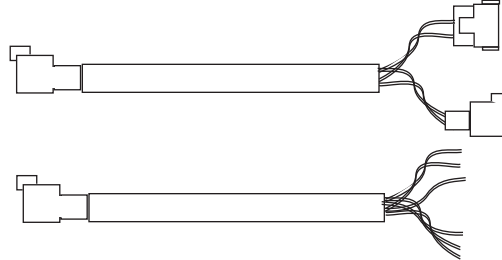


CAN BUS ADAPTER HARNESS

CAN Bus adapter harness attaches the ISO Hitch Extension to the first module harness “Module In” connector. Two harness styles are available (harness with Packard DICKEY-john IntelliAg style connectors and harness with wire fly leads).

Figure 6

CAN Bus Adapter Harness



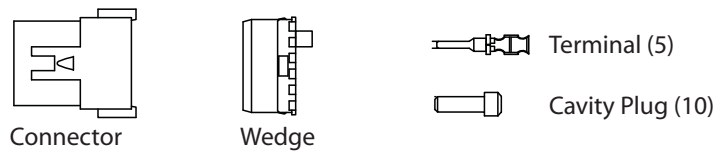
LIFT SWITCH/MASTER SWITCH ADAPTER KIT

A Lift Switch Adapter kit p/n 46798-8759 includes parts to assemble a connector to attach the implement lift switch input to the first “Master” module harness tramline connector, refer to [\(Figure 3\)](#) and [\(Figure 19\)](#). The kit includes a connector, wedge, (5) terminals, and (10) cavity plugs.

- The lift switch is attached at the module harness connector labeled “Tramline”. Any additional harnesses attached to the system do not use the “Tramline” connector input.

Figure 7

Lift Switch/Master Switch Adapter Kit

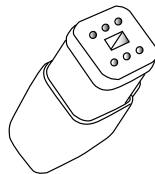


CAN TERMINATOR

A CAN terminator attaches to the “Module Out” connector on the last module within the system to close the connection point.

Figure 8

CAN Terminator





SYSTEM COMPONENTS

ISO COMPATIBLE VIRTUAL TERMINAL

Any ISO-compatible virtual terminal connects to the Daisy Chain system and provides seed sensor status during operation to quickly identify sensor issues. Daisy Chain setup is also performed using virtual terminal system setup screens.

Some ISO-compatible terminals include:

- DICKEY-john IntelliAg AI-120 (12" display), AI-110 (10" display), AI-50 (5" display)
- Case
- John Deere
- AGCO

Figure 9

Virtual Terminals

DICKEY-john AI-120



DICKEY-john AI-110



DICKEY-john AI-50



OPERATOR'S MANUAL





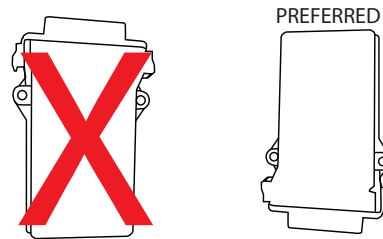
HARDWARE INSTALLATION

ATTACH MODULE TO IMPLEMENT

The Daisy Chain module should be mounted with the connector facing downward.

Figure 10

Acceptable Orientation



CAUTION

Do not install the module in any orientation other than shown in (Figure 10). The connection wires must not be mounted upward as moisture can collect inside the unit and damage the circuits. Ensure that module connectors do not face upward when implement is in a folded position as well.

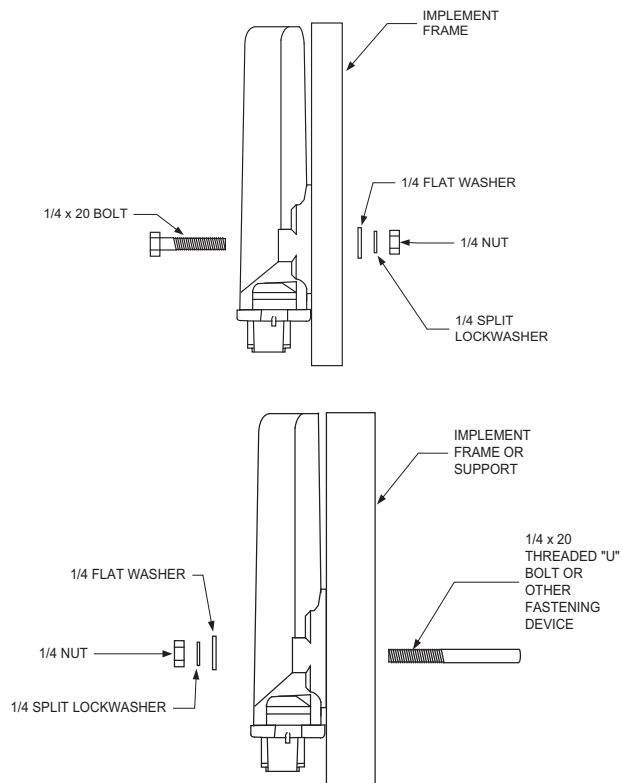
1. Mount with the label side of module facing out. Do not mount with the connector facing up (see Caution).
2. Select an area on the implement to mount the Daisy Chain module that allows for easy hookup and access. Harness extensions are available to reach modules across the implement.
3. Mount with the label side of the module facing out.
4. To bolt the Daisy Chain module to frame:
 - Use the enclosure as a template to mark the location of the mounting holes.
 - Drill two 9/32 inch diameter holes where marked.
 - Attach to frame using 1/4 x 20 bolts or other fastening devices as illustrated in (Figure 11).

CAUTION

Do not use the enclosure as a guide when drilling. Do not overtighten nuts as this may damage the mounting tabs on the enclosure.

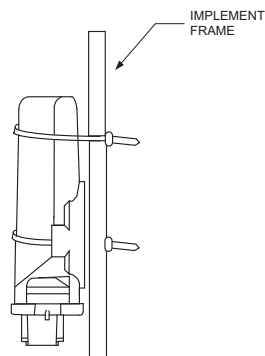


Figure 11
Secure Module to Frame



5. To tie-strap the module to a frame:
 - Use one long tie-strap to loop around the module body and through both mounting holes.
 - If necessary, drill mounting holes following the procedure described above.
 - Securely tighten tie-strap.
 - Install a second tie-strap toward the label end of the enclosure for additional support.

Figure 12
Tie Strap Module to a Frame



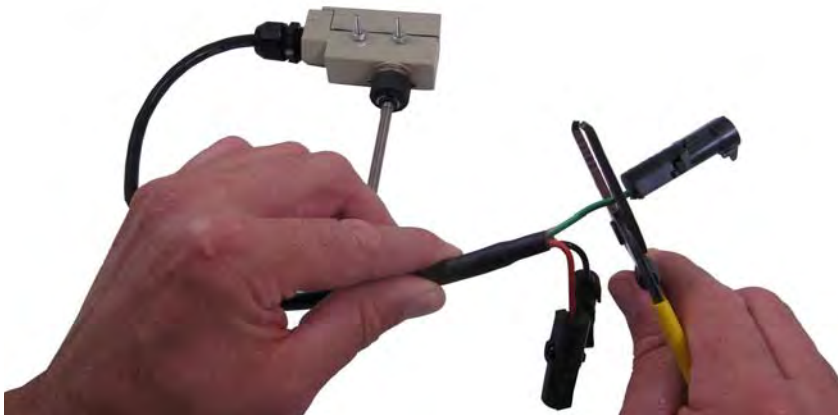


ASSEMBLE LIFT SWITCH CONNECTOR

1. Remove the existing "ground" connector from the lift switch by cutting the green wire near the base of the connector.
2. Remove the appropriate normally open or normally closed existing connector from the lift switch by cutting near the base of the connector.

Figure 13

Remove Existing Lift Switch Connectors



3. Place a terminal onto the lift switch "ground" wire and crimp securely.
4. Place a terminal onto the appropriate normally open or normally closed "lift switch" wire and crimp securely.
 - Use the black and green wires if the machine is down when the switch is deflected.
 - Use the black and red wires if the implement is down and the switch is not deflected.

Figure 14

Attach Terminal to Lift Switch Wires





5. Insert the "ground" terminal into pin 4 Accessory Ground input of the Deutsch connector until it snaps into place.
6. Insert the "lift switch" terminal into pin 6 Lift Switch input of the Deutsch connector until it snaps into place.

Deutsch Connector Pinout:

1	12V Power
2	12V Accessory
3	Accessory Ground Out
4	Accessory Ground
5	Input 5
6	Input 7, Lift Switch
7	Input 3
8	Input 1
9	Ground Speed
10	Input 2
11	Input 4
12	Input 6

Figure 15

Insert Terminal Pins



7. Insert wedge into the Deutsch connector using pliers until securely seated into place.

Figure 16

Insert Wedge into Connector





8. Insert cavity plugs into remaining unused inputs.

Lift switch connects to the first module harness marked as the Tramline connector. Refer to System Layout examples.

Figure 17

Insert Cavity Plugs





CONNECTING SENSORS ON LOOP

Sensors are connected together in a series within a loop.

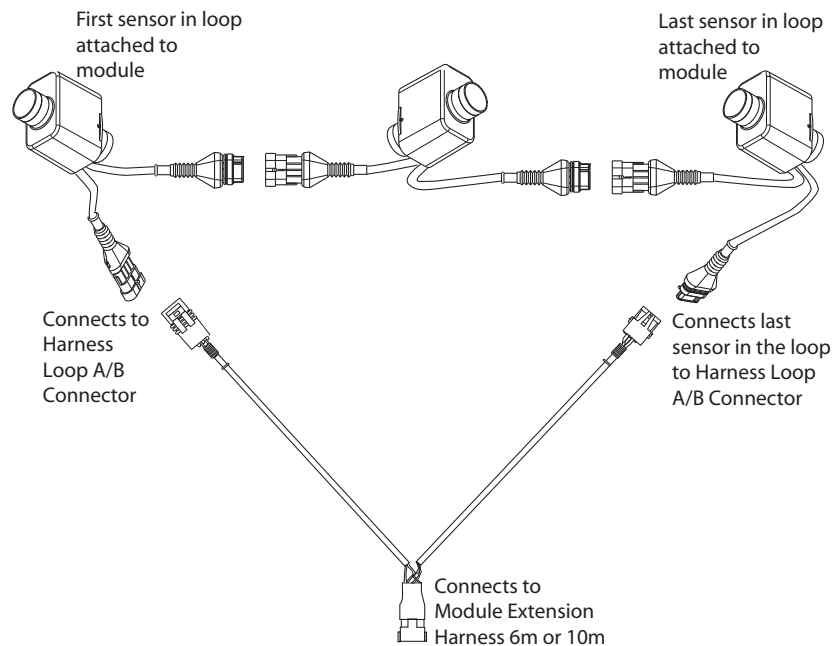
1. The sensor connected to cable B of the Harness Loop A/B connector is the first sensor on the loop.
2. Connect the remaining connector from sensor 1 and attach to sensor 2.
3. Repeat this process with all the sensors to complete the loop. A minimum of 2 sensors is required and a maximum of 54 sensors can be connected to a loop. A maximum of 432 sensors and 8 loops are possible.
4. Connect the last sensor in the loop to the Harness Loop A/B, cable A connector.

Sensor numbering is designated by the order of the sensors in the loop. Number sequencing occurs by loop type (seeder or fertilizer).

- Loop 1: sensor 1 to sensor 54
 - Example: seeder position 1 to 54
- Loop 2: sensor 1 to sensor 54
 - Example: fertilizer position 1 to 54
- Loop 3: sensor 1 to sensor 54
 - Example: seeder position 55 to 109
- Loop 4: sensor 1 to Sensor 54
 - Example: fertilizer position 55 to 109

NOTE: Be sure the locking tabs engage when inserting connectors. The connection is sealed only when the locking tabs have fully engaged.

Figure 18
Connecting Sensors on Loop





CONNECTING HARNESSES

Reference System Layout examples section for visual installation guidance.

1. Connect a module harness to the first module. This is the master module.
2. Connect the CAN Bus adapter harness to the ISO Hitch Extension harness and the "Module In" connector of the module harness.
3. Connect the Tramline (Lift Switch) connector to the vehicle's lift switch input (assemble and attach lift switch kit with mating connector to lift switch input, if required. Refer to Assemble Lift Switch Connector section).
 - The lift switch must be attached to the first module in the system. If additional module harnesses are used, the tramline connector is not used. Coil and secure the unused tramline connections.
4. Connect Loop 1 mating connector B of Loop A/B harness to the mating connector of the first sensor connector in the first loop.
5. Connect mating connector A of Loop A/B harness to the last sensor on the loop.
6. Connect an extension harness, if required, to the Loop 1 and Loop 2 connectors.
7. Connect the "Module Out" connector to the "Module In" connector of the next Module harness.
8. Continue to connect modules and harnessing following steps 4 - 9.
9. Connect a terminator to the "Module Out" connector of the last module harness.

IMPORTANT: Be sure the locking tabs engage when inserting the connectors. The connection is sealed only when the locking tabs have fully engaged.



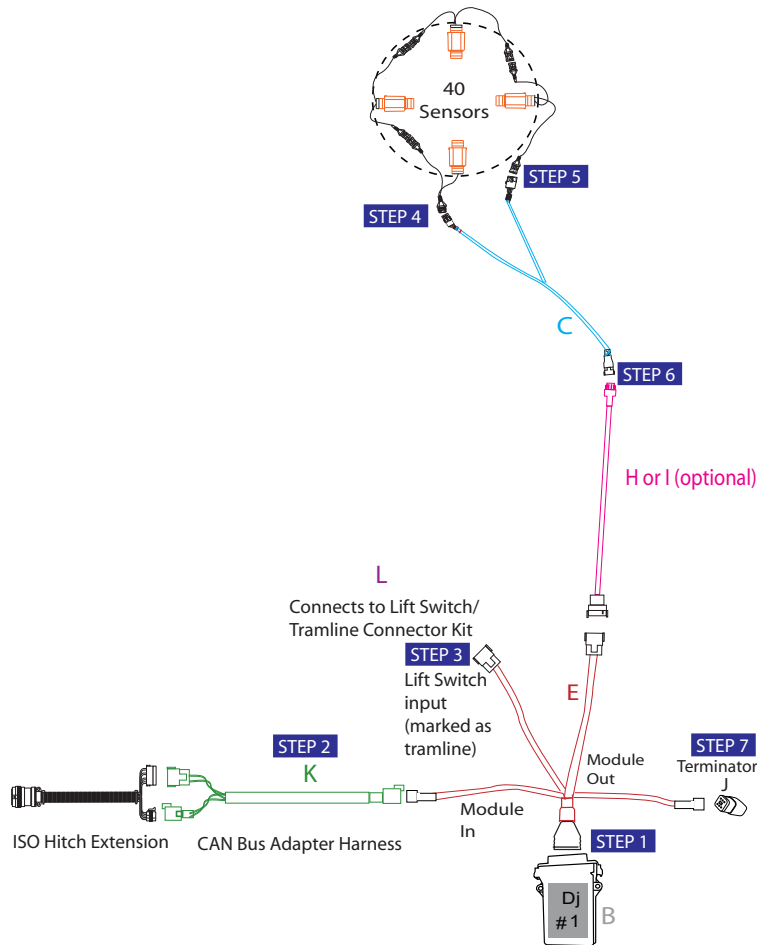
SYSTEM LAYOUT EXAMPLES

The following diagrams illustrate several layouts and connections of modules and sensors. Refer to the Connecting Harnesses sections for step instructions.

SINGLE MODULE WITH ONE LOOP

Figure 19

Single Module With One Loop



- A 467988670 Daisy Chain Sensor
- B 467988690 Daisy Chain Sensor Module
- C 467988749 Daisy Chain Harness Loop A/B Connector 1 Loop
- E 467988720 Daisy Chain Module Harness ISO 1 Loop
- H 467988741 Module Extension Harness 6 meter
- I 467988740 Module Extension Harness 10 meter
- J 467988761 Terminator
- K 467988751 CAN Bus Adapter Harness with Dj IntelliAg
CAN Bus compatible connector or
- K 467988752 CAN Bus Adapter Harness with Wire Fly Leads
- L 467988759 Lift Switch/Tramline Connector Kit



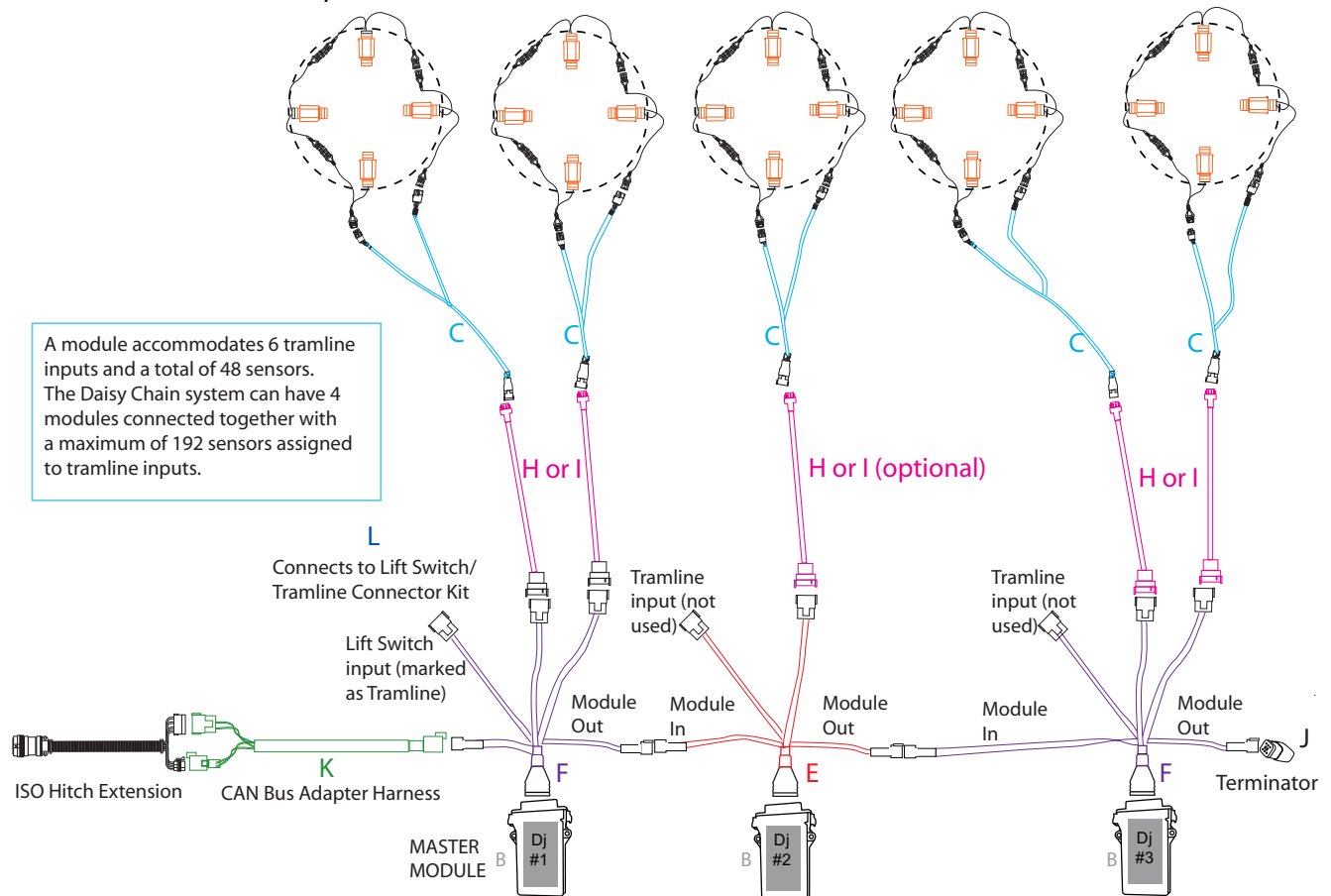
MULTI MODULES AND LOOPS

In a multi-module system, the first module in the system is the Daisy Chain sensor master module. A minimum of 2 sensors must be attached to a loop with a maximum number of 54 sensors per loop for a total of 432 total sensors (8 loops). Each module can interface with a maximum of 2 sensor loops.

DJ#1 in each illustration is the first module connected to the CAN bus and considered the master module.

Figure 20

Three Modules With Five Loops

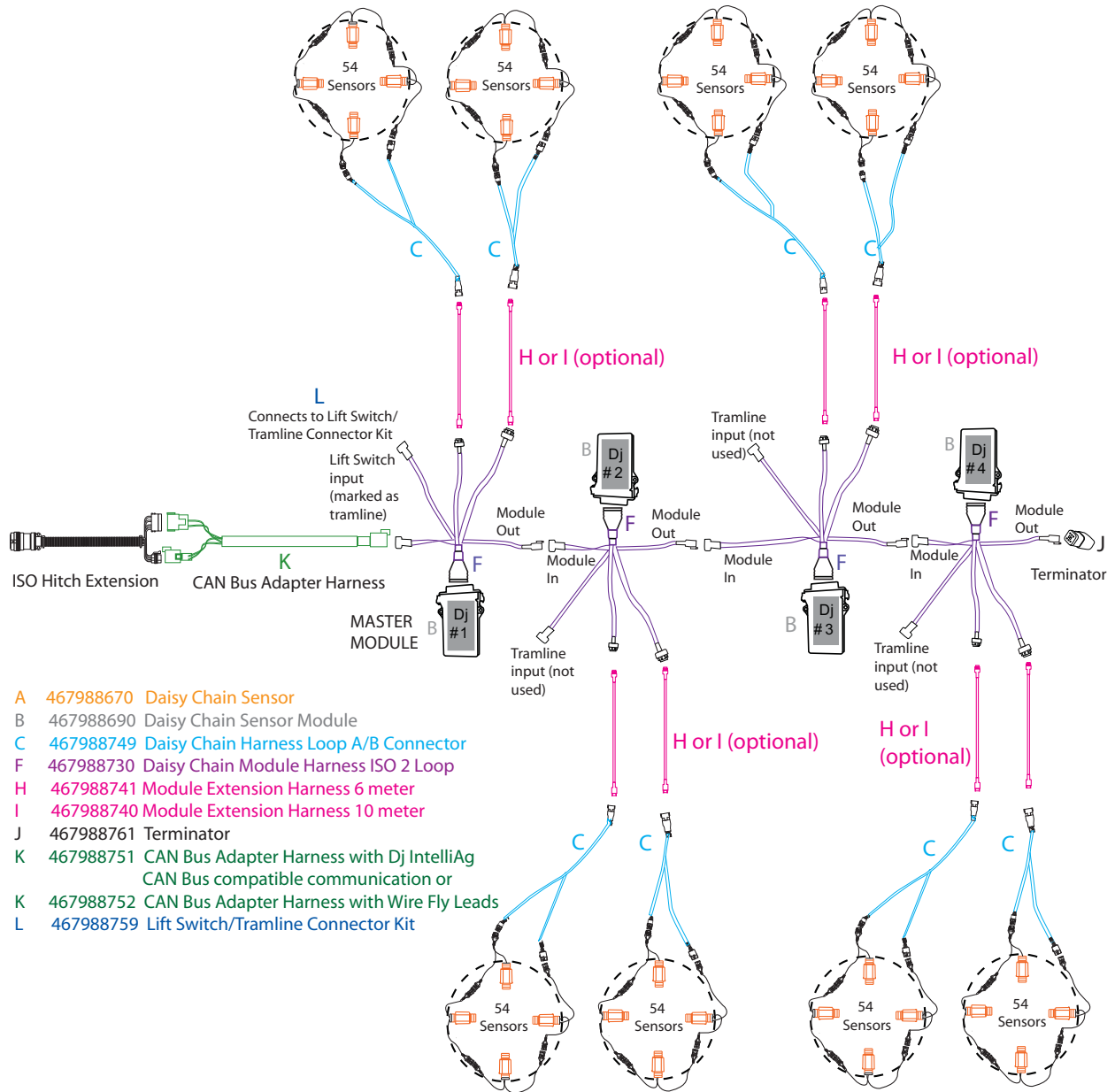


- A 467988670 Daisy Chain Sensor
- B 467988690 Daisy Chain Sensor Module
- C 467988749 Daisy Chain Harness Loop A/B Connector
- E 467988720 Daisy Chain Module Harness ISO 1 Loop
- F 467988730 Daisy Chain Module Harness ISO 2 Loop
- H 467988741 Module Extension Harness 6 meter
- I 467988740 Module Extension Harness 10 meter
- J 467988761 Terminator
- K 467988751 CAN Bus Adapter Harness with Dj IntelliAg
CAN Bus compatible connector or
- K 467988752 CAN Bus Adapter Harness with Wire Fly Leads
- L 467988759 Lift Switch/Tramline Connector Kit



Figure 21

4 Module System with 8 Loops and 432 Sensors Using Extension Harnesses





INITIAL POWERUP

Setup screens are accessed from the IntelliAg screen by pressing the **Daisy Chain** button located on the left application side bar.



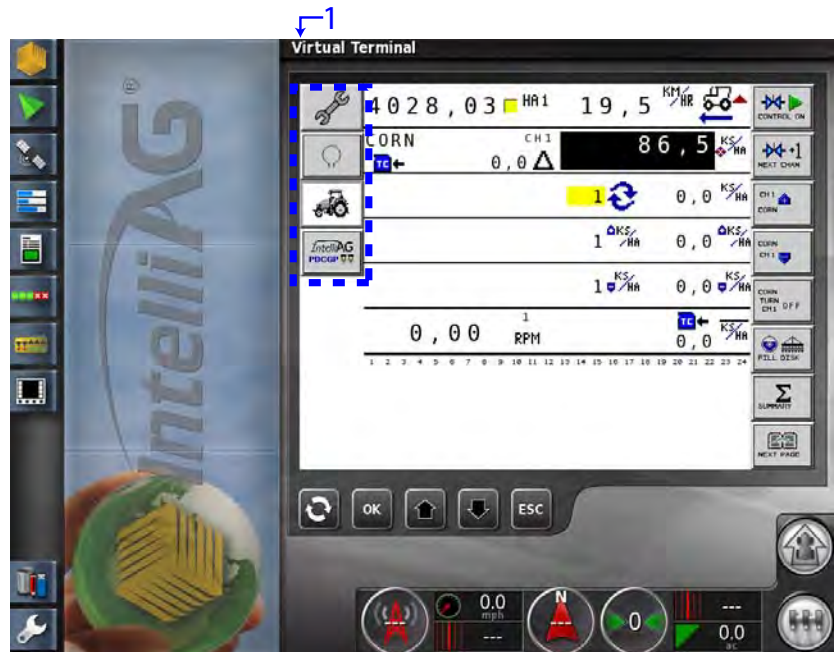
Daisy Chain button

To Display the Daisy Chain System Screens:

1. At the IntelliAg screen, press the **Daisy Chain** button.

Figure 22

IntelliAg Work Screen



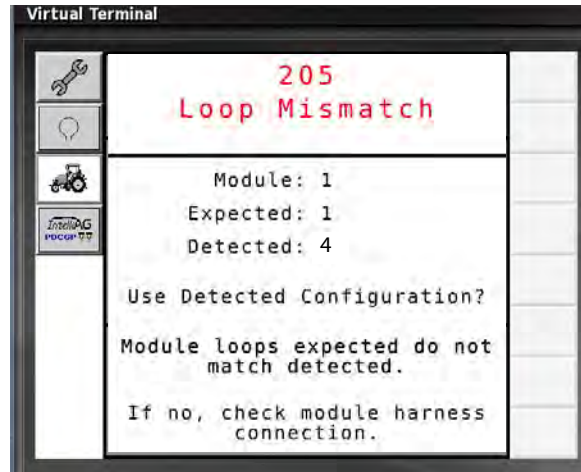
At initial powerup, the system performs an auto configuration for the number of modules and loops connected. A Configuration Warning screen must be acknowledged to proceed to the Daisy Chain System Main Message Center screen.

To Accept Auto Configuration screen:

1. During the initial auto configuration, a Loop Mismatch alarm displays indicating the number of modules expected and detected do not match.
 - Press the **Yes** button to use the detected configuration and proceed.



Figure 23
Auto Configuration Screen



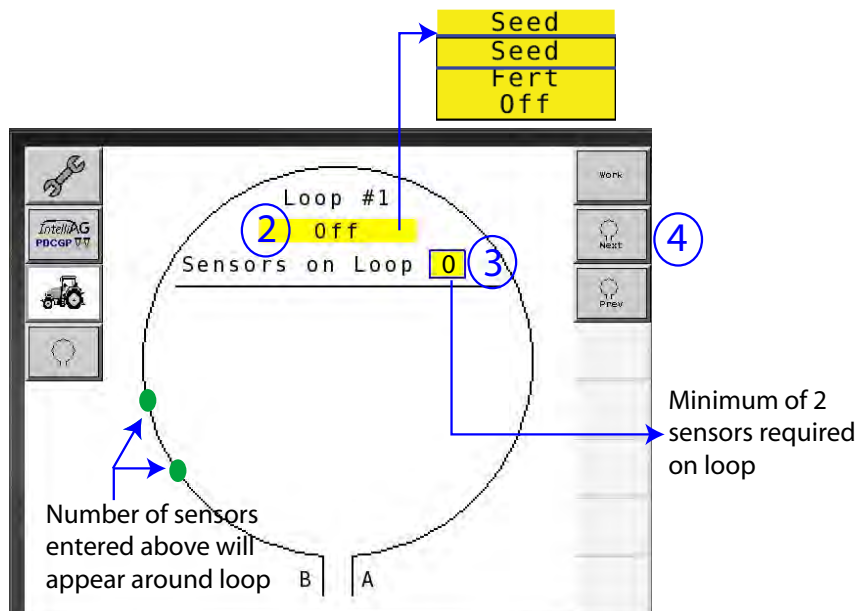
INITIAL SETUP

2. Press the *Sensors on Loop* input box and enter the number of sensors installed on the loop.
 - A minimum of 2 sensors must be installed with up to a maximum of 54.
 - The number of sensors entered will display around the loop onscreen in green. If the number of sensors entered onscreen does not match the actual number of sensors installed on the loop, the actual detected number of sensors appear in green and the additional sensors appear in blue. Sensor address assignment starts with the the first sensor “B” connector that is attached to the extension harness “Y” connector. Each attached sensor thereafter is assigned sequentially.
 - After loops and sensors are assigned, additional functions display relative to the module and sensors connected to the loop.
3. Press the material type selection box and select the loop type as seed, fertilizer, or off.
 - OFF turns off the communication to the loop when not in use.
4. Press the **Next Loop** button to assign material type and sensors to the next loop, if any. Continue setting up all loops until assignment is complete.





Figure 24
Initial Sensor Setup





LOOP SETUP SCREEN FUNCTIONS

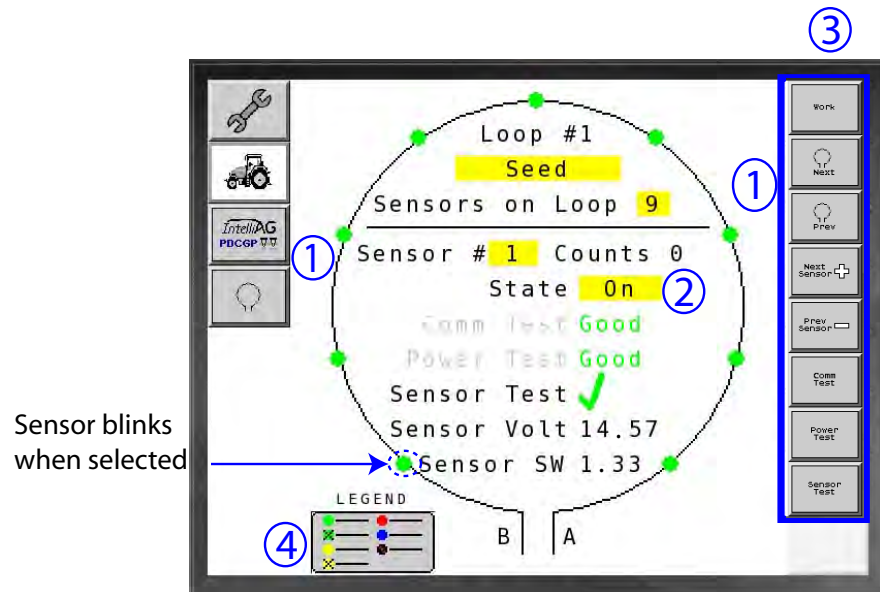
After loops and sensors are assigned, additional functions display on the Loop Setup screen relative to the module and sensors connected to that loop. The selected Loop appears as "Loop #1, 2" etc. at the top of the screen.

To Navigate the Loop Setup Screen:

1. A specific sensor on a loop can be selected by:
 - pressing the *Sensor* input box and using the keypad to enter the sensor number or
 - pressing the **Next Sensor** or **Previous Sensor** button
 The sensor location on the loop will blink when selected.
2. Press the *State* input box to select sensor functionality as
 - ON (default mode that allows sensor monitoring when the system is active)
 - OFF (removes sensor from the loop sequence to eliminate continuous alarms)
3. A series of buttons on the right side bar provide onscreen navigation and to other Daisy Chain screens.
4. The *Sensor Legend* provides a description of possible sensor states. The active state of each sensor appears onscreen to immediately determine sensor/blockage issues.

Figure 25

Loop Setup





LOOP SETUP BUTTONS

WORK

Exits the Loop Setup screen and returns to the Main "Message Center" screen.

NEXT LOOP

Selects the next loop connected to the system.

PREVIOUS LOOP

Selects the previous loop connected to the system.

NEXT SENSOR

Selects the next sensor on the loop. A selected sensor will flash onscreen and auto populates the Sensor input box onscreen.

PREVIOUS SENSOR

Selects the previous sensor on the loop. A selected sensor will flash onscreen and auto populates the Sensor input box onscreen.

COMMUNICATION TEST

A communication test should be performed after issues within the loop or the module has been repaired to verify system is corrected. This test must pass before a Power test. A communication test returns a "Good", "Limited", or "Failed" result.

POWER TEST

A power test checks that the system is receiving adequate power between the module, loop, and sensors. A power test returns a "Good" or "Unknown" result.

SENSOR TEST

A sensor test checks each sensor on a loop to verify a sensor is operating efficiently. A sensor test results in a "check mark" (pass) or "question mark" (unknown) result.



SYSTEM OPERATING STATES

The Daisy Chain system has 4 operating states that indicate system status:

NOT READY STATE

Occurs during all initializations and startup procedures based on the stored configuration. At completion of this process, the Daisy Chain transitions to either a Ready or Failed state. If hardware configuration does not match the stored configuration, alarms are generated indicating issues that need resolved.

READY STATE

Represents the inactive state of the machine. System is on standby to begin operating. Typically a lift switch transitions the system from the ready state to the run state when the machine transitions from in and out of work mode.

RUN STATE

The machine is operating in the work mode and blockage monitoring is active.

FAILED STATE

Failed State screens display in red and occur anytime the system encounters a system, power, or communication failure. This failure must be corrected before the system can function.



DAISY CHAIN SYSTEM OPERATION

On powerup, the last configuration stored on the Daisy Chain system is the configuration that is checked against to verify the system still matches the physical setup. If hardware configuration does not match the stored configuration, an alarm occurs and needs to be resolved.

The Daisy Chain blockage system becomes active when the lift switch is engaged and inactive when the lift switch is disengaged. Any system status changes detected generates an alarm message that indicates an issue within the system. Only one active alarm can occur at a given time. Once an alarm is acknowledged, the next highest alarm, if any, will display.

The system is designed with a redundant communication between sensors so that any defective sensor within the system does not shutdown the entire blockage system. A blocked or faulty sensor is identified onscreen that quickly pinpoints the sensor location with issues.

Blockage status can be viewed on two screens:

- Message Center (system overview and status of all connected loops)
- Loop Setup (individual loop and sensor status)

MESSAGE CENTER SCREEN

The Message Center screen provides an overview of all loops within the system, the number of sensors connected to a loop/module, identifies loop blockage, and sensors assigned to tramlining.

In a multi-module system, the first module in the system connected to the CAN bus is assigned as the master module.

Navigating the Message Center screen:

1. The Message Center screen displays all modules and loop assignments found during startup.
2. Press the **Loop Setup** button or the loop onscreen to view loop and sensor status.
3. Current state of the loop is identified with symbols.
4. Seed sensitivity setting default is set at 5 for both seed and fertilizer channels. Too high or low of a setting can cause increased alarm occurrences.

IMPORTANT: An adjustment to this setting may be required for smaller seeds if a signal pulse is not captured by a sensor causing a false blockage reading to occur.

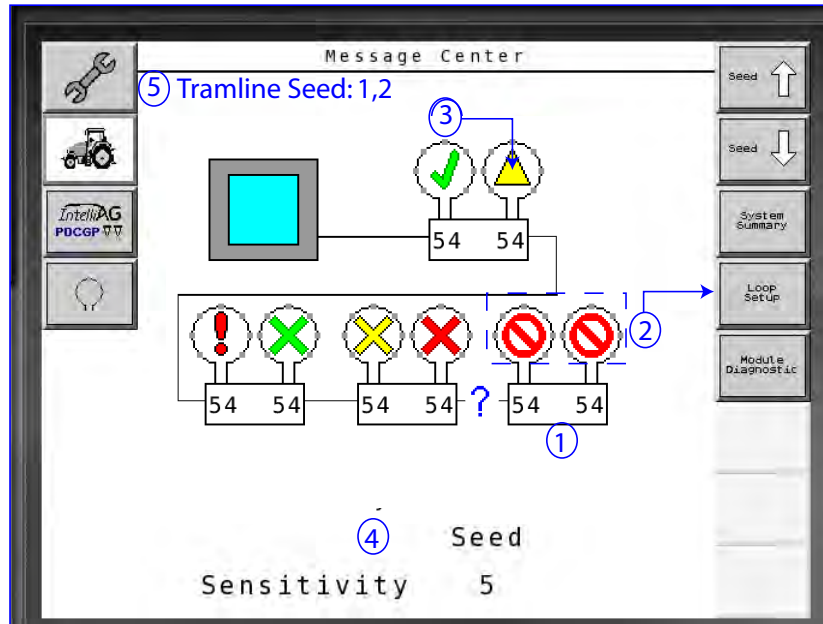
- 10 is the highest sensitivity reading
 - 0 is the lowest sensitivity reading
5. If tramline is enabled, sensors that are set to tramline for seed and fertilizer appears at screen top.

Sensitivity Setting	Percentage Setting
0	35%
1	40%
2	45%
3	50%
4	55%
5	60%
6	65%
7	70%
8	75%
9	80%
10	85%

NOTE: Refer to the Tramline Setup section p. 35.

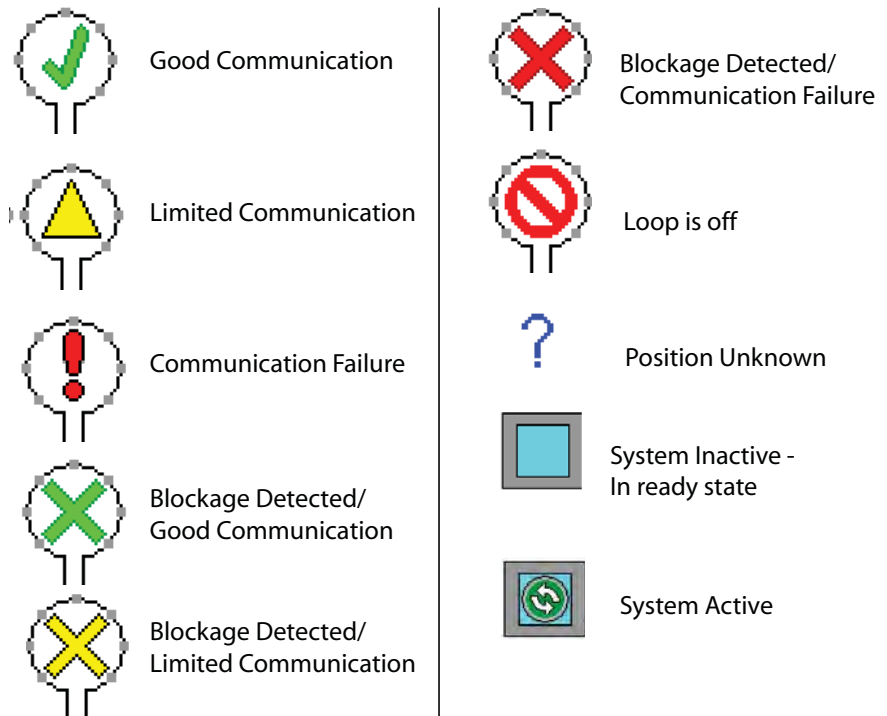


Figure 26
Daisy Chain Message Center Screen



NOTE: Refer to page 29 for loop status symbol definitions

Figure 27
Loop Status Symbols





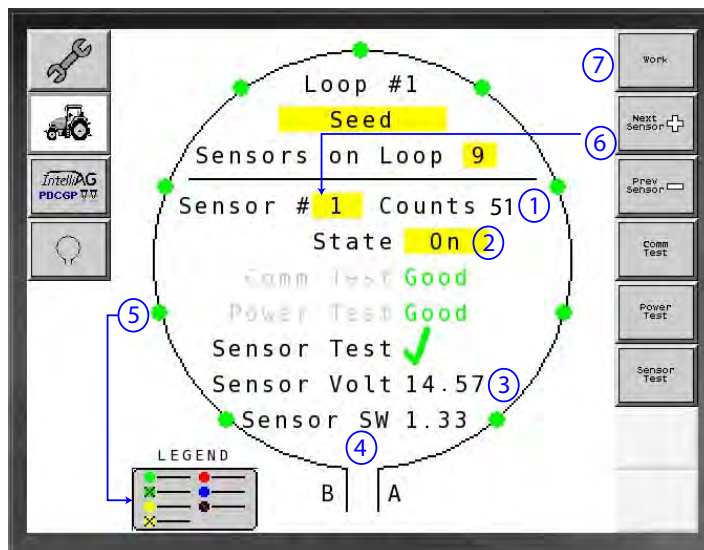
LOOP SETUP

The Loop Setup screen identifies critical system parameters for the selected loop. A visual display indicates sensor status, seed count per second for selected sensor, and pinpoints sensor issues. A color-coded legend describes current sensor state.

1. The *Counts* field automatically populates every 1 second indicating the actual seed flow passing through the selected sensor.
2. The *State* input field can be set to either:
 - **On** (an active sensor on the loop) or
 - **Off** (an inactive sensor on the loop) prevents alarms from occurring during operation for a specific sensor.
3. *Sensor Voltage* value is the detected voltage of the selected sensor on the module. A sensor value less than 10V triggers alarms.
4. *Sensor SW* identifies the software version of installed sensors and is for informational purposes only.
5. Sensors attached to the loop are color coded to identify current sensor status. The Sensor Legend describes the sensor status after Communication, Power, and Sensor tests are performed. Refer to the System Tests section for legend definitions.
6. Selecting a sensor on the loop:
 - Press the **Next Sensor** or **Previous Sensor** button.
 - Enter the sensor number in the *Sensor* input box.
7. Press the **Work** button to return to the *Message Center screen.*

Figure 28

Loop Setup During Operation





SYSTEM TESTS

Three System Tests check or reset the current state of the system.

IMPORTANT: A Communication test must be performed first and pass successfully before a Power test is allowed.

There are 3 sensor legends that define the state of the sensor after each specific test is performed.

COMMUNICATION TEST

A Communication Test is required after communication issues have occurred in the system:

- Signal failure between modules and sensors
- Configuration mismatch
- Loop mismatch

To Perform a Communication Test:

1. At the Loop Setup screen, press the **Communication Test** button. A system check results in 3 possible states:
 - Good (checks and confirms system is working)
 - Limited (checks and confirms system is operating with one line of sensor communication)
 - Fail (checks and confirms that a complete communication failure has occurred in the system that must be repaired.) A failure will trigger a full screen alarm with the type of failure that has occurred.

Figure 29

Communication Test Failure

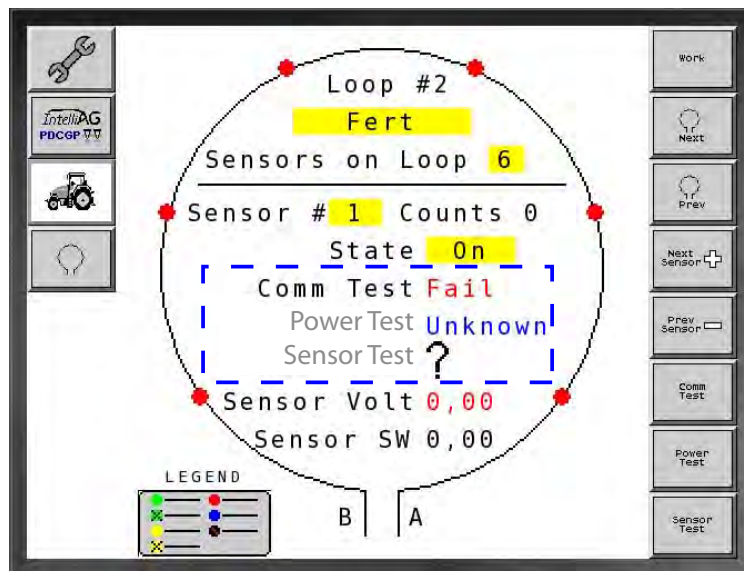
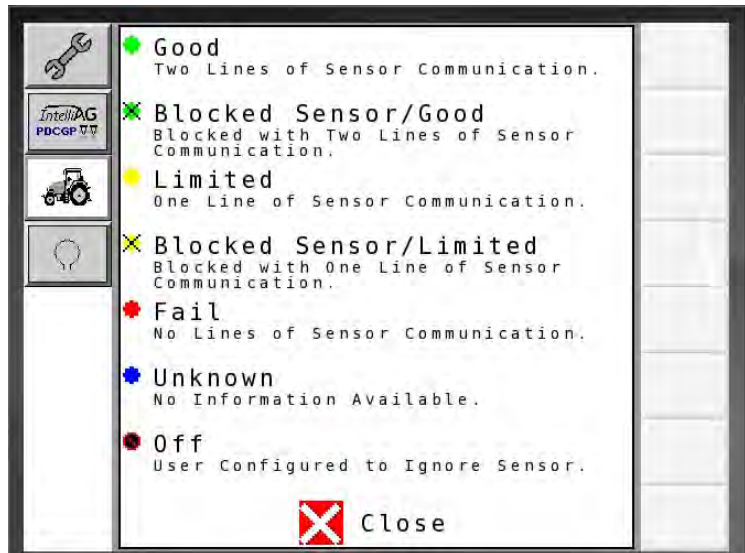




Figure 30

Communication Test Sensor Legend



COMMUNICATION SENSOR LEGEND

The Communication Sensor Legend identifies the seven possible states of a sensor:

GOOD

Sensor and communication lines have passed self test and are operating efficiently.

BLOCKED SENSOR/GOOD

A sensor blockage is detected that should be addressed. Communication lines are operating efficiently.

LIMITED

There is a break in communication between 2 sensors. Communication is still occurring with other sensors on the loop in a limited capacity (1 line).

BLOCKED SENSOR/LIMITED

A blocked sensor is found as well as a break in communication between sensors. Communication is still occurring with other sensors on the loop in a limited capacity (1 line).

FAIL

Multiple breaks in the communication line have occurred between sensors and/or modules and the system can no longer function.

UNKNOWN

A configuration mismatch has occurred. Number of sensors detected does not match sensors expected.

OFF

Sensor is set to OFF on the Loop Setup screen and the sensor is ignored to prevent alarm occurrences.



POWER TEST

Power failures occur due to lost power between sensors.

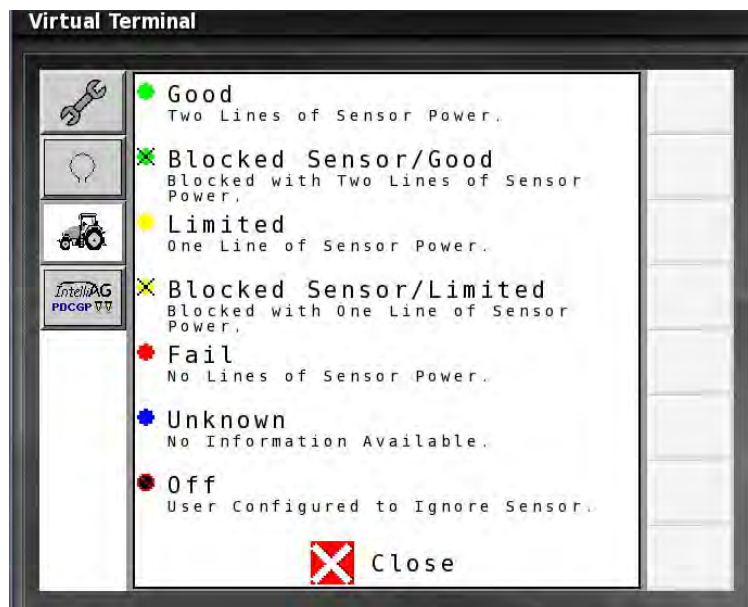
To Perform a Power Test:

1. At the Loop Setup Screen, press the **Power Test** button. A system check results in 2 possible states:
 - Good (checks and confirms power communication is working)
 - Unknown (checks and confirms power communication is not found)

Power test results appear on the Loop Setup screen as shown in [\(Figure 29\)](#).

Figure 31

Power Test Legend



POWER LEGEND

The Power Legend identifies the seven possible states of a sensor:

GOOD

Sensor has passed self test and is operating efficiently with two lines of sensor power.

BLOCKED SENSOR/GOOD

A sensor blockage is detected that should be addressed. Power lines are operating efficiently.

LIMITED

There is a break in power between 2 sensors. Power is still occurring with other sensors on the loop in a limited capacity (1 line).



BLOCKED SENSOR/LIMITED

A blocked sensor is found as well as a break in power between sensors. Power is still good with other sensors on the loop in a limited capacity (1 line).

FAIL

Multiple breaks in the power line have occurred between sensors and/or modules and the system can no longer function.

UNKNOWN

A configuration mismatch has occurred. Number of sensors detected does not match sensors expected.

OFF

Sensor is set to OFF on the Loop Setup screen and the sensor is ignored to prevent alarm occurrences.

SENSOR TEST

Sensor failures can occur to due:

- Low voltage
- Dirty sensors

A sensor test check results in 2 possible states ([Figure 29](#)):

- Check mark (pass)
- Question mark (sensor state unknown)

To Perform a Sensor Test:

1. At the Loop Setup screen, press the **Sensor Test** button. A Self Test window displays during test. The self test runs a check on all sensors.
 - The onscreen **Cancel** button can be pressed at any time to stop self check.
2. At completion, press the green **OK** button to exit.

Figure 32

Self Test Window

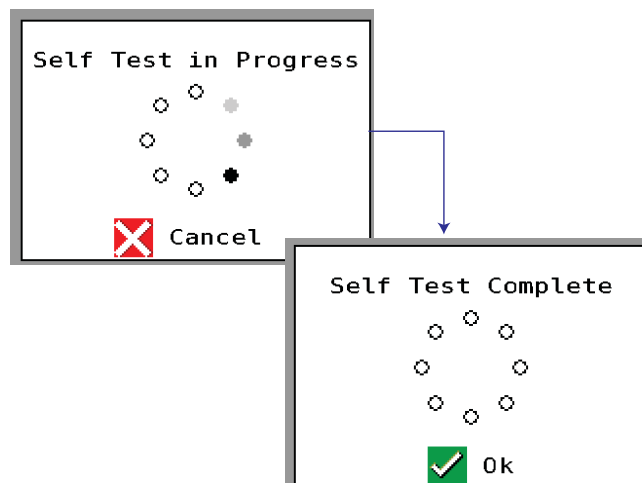
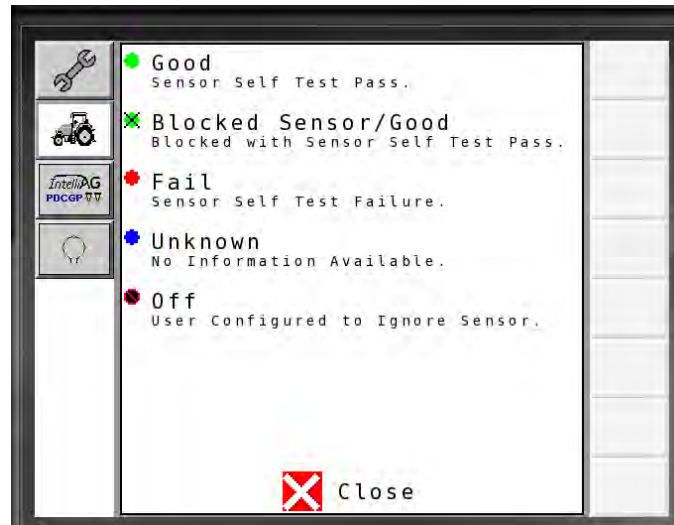




Figure 33

Sensor Legend



SENSOR LEGEND

The Sensor Legend identifies the five possible states of a sensor:

GOOD

Sensors have passed self test and are operating efficiently.

BLOCKED SENSOR/GOOD

A sensor blockage is detected that should be addressed. Communication lines are operating efficiently.

FAIL

A sensor has failed and cannot detect blockage.

UNKNOWN

A configuration mismatch has occurred. Perform a Communications test to determine the number of sensors that are detected and what is expected.

OFF

Sensor is set to OFF on the Loop Setup screen and the sensor is ignored to prevent alarm occurrences.



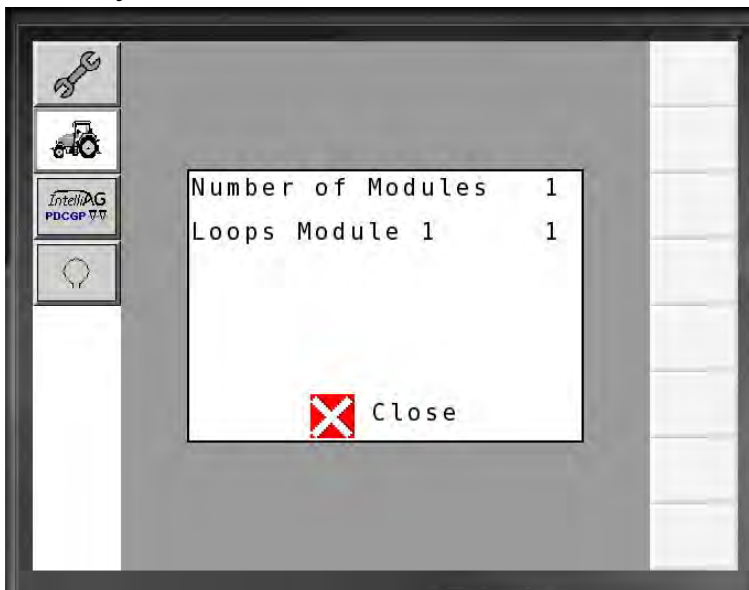
SYSTEM SUMMARY

System Summary is an informational screen that provides an overview of number of modules and loops assigned to each module.

1. At the Message Center screen, press the **System Summary** button to display this screen.

Figure 34

System Summary Screen







TRAMLINE SETUP

Tramline functionality alerts the daisy chain module to ignore sensors if blockage is found on any sensors that are configured as tramline. Sensors for seeders identified for tramlining are considered disabled and no longer need to be monitored until reactivated.

NOTE: Module and sensor assignment must be setup first before assigning sensors for tramlining.

Sensor assignment for tramlining is based on the module, loop, and tramline configuration. Each module is allowed 6 tramline inputs with a maximum of 8 sensors per tramline input. A total of 48 sensors can be assigned to a module for tramlining.

Sensors are numbered according to the module and loop type configuration of the sensors.

EXAMPLES:

Two modules with one module containing two loops and 20 sensors and one module with one loop containing 20 sensors

MODULE 1

- Loop 1 configured for seed: 1-20
- Loop 2 configured for fertilizer: 1-20

MODULE 2

- Loop 1 configured for seed: 21-41

One module containing the same two loop types.

MODULE 1

- Loop 1, Seed: 1-20
- Loop 2, Seed: 21-41

SETUP

To enable tramline, the following functions must be identified:

- Module input type
- Input state
- Sensor assignment
- Auxiliary power (needed only if lift switch is used)

INPUT TYPE

Module input type for tramlining must match the loop setup of the module defined at the Loop Setup screen. A tramline type can be set as:

- Seed
- Fertilizer
- Off (sensors assigned to tramline are cleared)



INPUT STATE (HI/LO)

Tramline inputs for each module are connected to ground or a voltage which represents either 'Lo' or 'Hi' on the screen. If the tramline input is tied to ground and the tramline input on the screen is set to 'Lo', then the tramline input is considered to be in an 'On' state. A tramline input set to 'Hi' as the input would be considered the 'On' state when voltage is present.

ASSIGNING SENSORS

Eight sensors can be assigned to a tramline input. Sensor assignment to a tramline is based on the module, loop, and tramline configuration. There are six tramline inputs for each module; therefore, a total of 48 sensors per module can be assigned.

The system prevents the same sensor number assignment to a module and does not allow a sensor to be assigned to a tramline from a different module. If a sensor number duplication occurs, that number is automatically removed and a different number must be selected.

AUXILIARY POWER

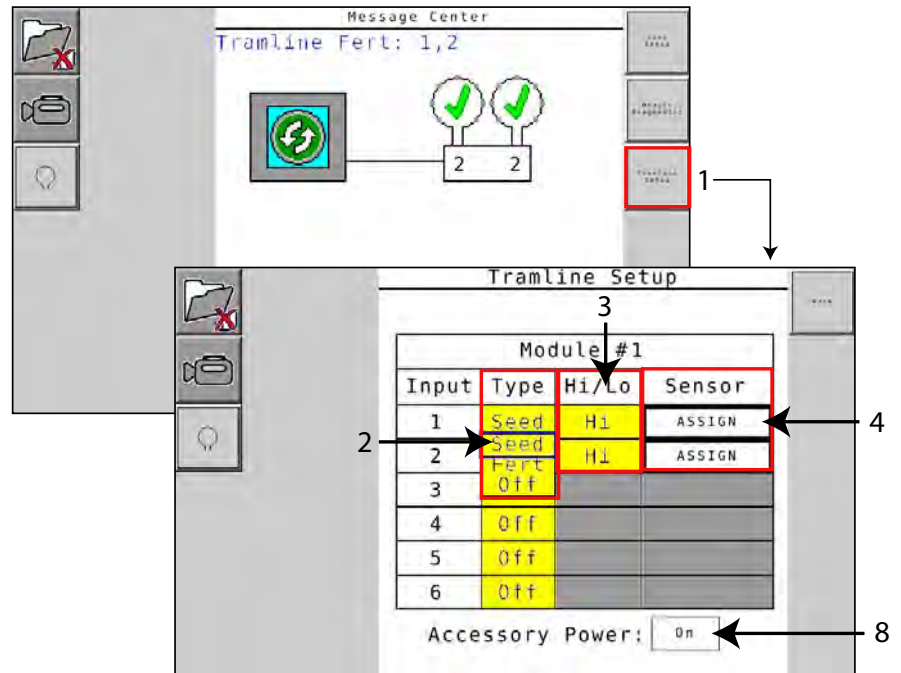
The Accessory Power button is default set to OFF and should be set to ON if 12 volt accessory power is required from a module for use with a lift switch. Maximum current rating for the 12V output is 1 Amp.

To Set Tramline Functions:

1. At the Message Center screen, press the **Next Page** button and select the **Tramline Setup** button.
2. At the Tramline Setup screen, highlight the Type column, and use the rotary knob to select Seed, Fertilizer, or Off or type in '0' to clear the sensor number.
3. Select the Hi/Lo column and set the module input state as HI or LO.
4. Select the Sensor column to display the Sensor Setup screen.

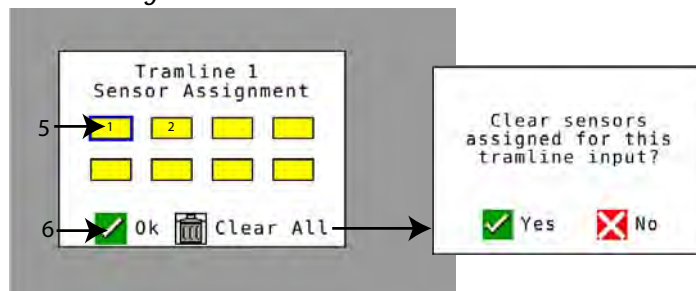


Figure 35
Tramline Setup



5. Highlight the first sensor yellow input box. Push in the rotary button and scroll to select a desired sensor number.
 - Push the rotary button to accept the number and to proceed to the next sensor input box until all sensors are added.
 - To clear a single sensor number, push in the rotary button until the button flashes, turn the knob until the field is clear, push the rotary button to accept.
 - If a duplicate number is entered, a message displays indicating that the number is already assigned and clears the duplicate from the box.
 - To clear ALL sensor numbers from input boxes, press the **Clear All** button.
6. Press the **OK** button to accept.

Figure 36
Sensor Assignment



7. To enable auxiliary power, press the Accessory Power input box and choose ON.





CHANGING THE LANGUAGE

The default language of English can be changed to the following languages for the Daisy Chain Blockage system:

- Czech
- French
- German
- Russian
- Spanish

To Change the Language:

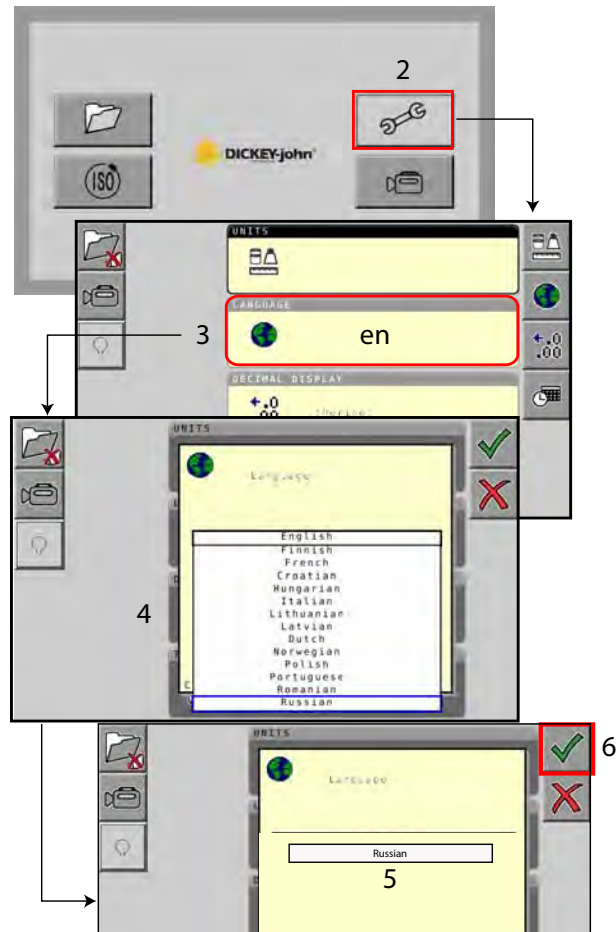
1. Press the **Home** button located on the bottom right of terminal.
2. At the Terminal Menu screen, press the **Setup** button.
3. Select the **Language** button.
4. Scroll to select one of the above identified languages.
5. Push in the rotary button to accept. The selected language displays onscreen.
6. Press the **Check Mark** button to proceed with change.



HOME
button

Figure 37

Changing the Language







MODULE DIAGNOSTICS

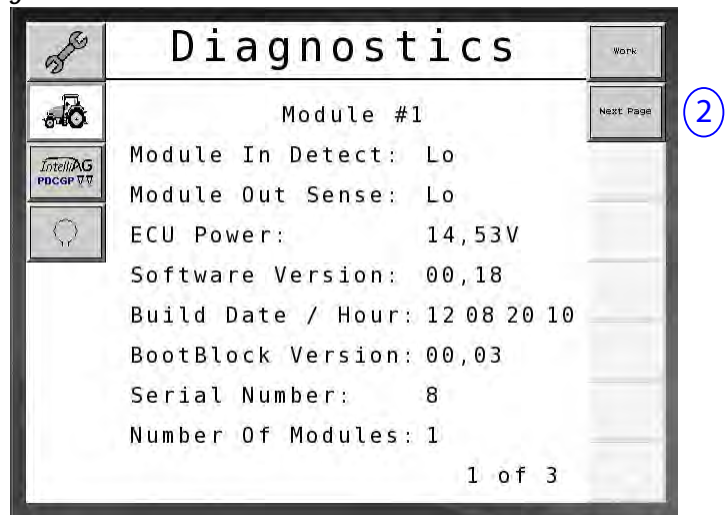
Diagnostics screens identify various information relevant to system modules typically used for troubleshooting purposes.

Each module has a total of 3 Diagnostics screens. These screens are informational only and cannot be edited. The system can be active while viewing the Diagnostics screen.

1. At the Message Center screen, press the **Module Diagnostics** button.
 - Press the **Next** button on the Diagnostics screen to scroll through the various screens for the module selected.
 - Press the **Module** button to display Diagnostics screens for additional modules.

Figure 38

Module Diagnostics Screens



DIAGNOSTICS SCREEN 1

MODULE IN DETECT

Module In Detect value is a “High” or “Low” state used for troubleshooting. High = open and Low = grounded

MODULE OUT SENSE

Module Out Sensor value is a “High” or “Low” state used for troubleshooting. High = open and Low = grounded

ECU POWER

The Electrical Control Unit (ECU) Power value is the detected ECU voltage. This voltage level is the low current voltage leg of the system and is used to power modules and sensors. This value will generally be equal or nearly equal to the tractor battery voltage.



SOFTWARE VERSION

Software version of the module.

BUILD DATE/HOUR

Date and hour of manufacture of the module.

BOOT BLOCK VERSION

Boot block version of the module.

SERIAL NUMBER

Each module is identified by a serial number. This serial number is also located on a label on the module.

NUMBER OF MODULES

Number of detected modules connected to the system.

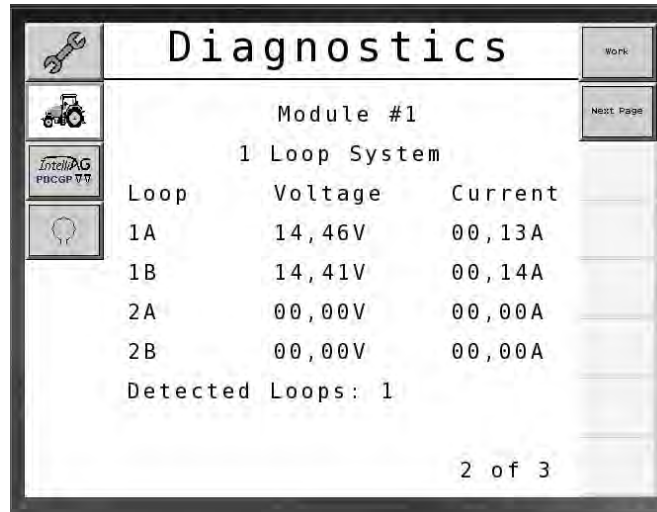
DIAGNOSTICS SCREEN 2

The second Diagnostics screen identifies the detected number of loops connected to a module.

The voltage and current readings are identified for each loop.

Figure 39

Module Diagnostics Screen (Screen 2 of 3)





DIAGNOSTICS SCREEN 3

The third Diagnostics screen indicates system output values for connected components.

TRAMLINE INPUTS 1-6

Tramline input setting indicates the input state as high or low in which the tramline input is considered "ON" when voltage is present.

LIFT SWITCH

The Lift Switch value displays the output signal of the lift switch as "High" or "Low".

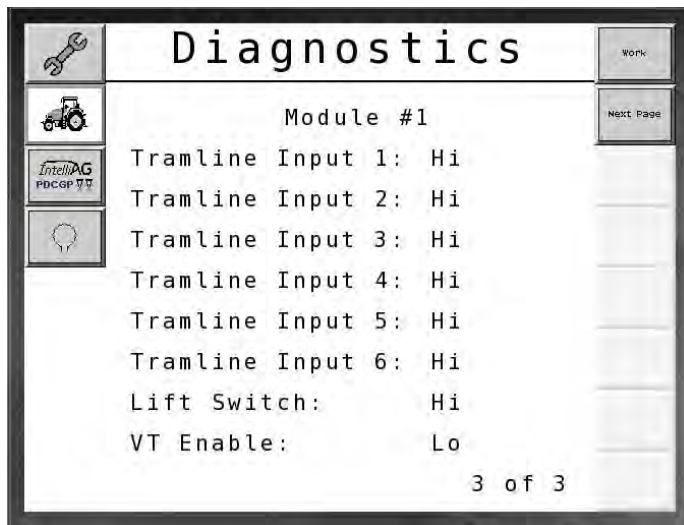
- High indicates the open position and system is not active.
- Low indicates lift switch is grounded and system is active.

VT ENABLE

VT Enable value is set at "Low".

Figure 40

Module Diagnostics Screen (Screen 3 of 3)







ALARMS

Full-screen alarms display onscreen when conditions occur outside normal operating parameters.

- 100 level alarms are critical alarms relating to system issues or loop mismatches. These alarms must be corrected before operation can proceed.
- 200 level alarms relate to loop and sensor power failures.
- 300 level alarms relate to sensor failures.
- 400 level alarms indicate blockage and module failures.

Contact DICKEY-john Technical Support at 1-800-637-3302 for troubleshooting assistance.



OPERATOR'S MANUAL



ALARM #	ALARM	PROBABLE CAUSE	CORRECTIVE ACTION
100	Loop Shutdown	Voltage supplied to module is above the maximum operating level of 18V. Loop automatically shuts down to protect from damage.	1) Check all harnesses for loose connections. 2) Vehicle charging system is not being regulated. Check vehicle charging system for proper voltage.
101	ECU Low Voltage	Voltage supplied to module is below the minimum level of 11V.	1) Check all harnesses for loose connections. 2) Vehicle charging system is not being regulated. Check vehicle charging system for proper voltage.
102	ECU High Voltage	Voltage supplied to module is above the maximum of 16V.	1) Vehicle charging system is not being regulated. Check vehicle charging system for proper voltage.
103	Low Voltage	Voltage level detected on the loop is below the minimum of 11V.	1) Modules could be receiving low voltage. Check all harnesses for loose connections. 2) Vehicle charging system is not being regulated. Check vehicle charging system for proper voltage.
104	High Voltage	Voltage level detected on the loop is above the maximum of 16V.	1) Modules could be receiving low voltage. Check all harnesses for loose connections. 2) Vehicle charging system is not being regulated. Check vehicle charging system for proper voltage.
105	High Current	Current is exceeding 5 Amps on the loop.	1) Check for pinched wires, faulty pins, or bad sensor. 2) Check for faulty ground in the system.
106	Position Failure	Module positioning has failed.	1) Check module harnesses. May require a volt meter to verify that pin 5 in module in and module out connectors are grounded.
107	Accessory Power Short	Accessory Power is shutdown due to a possible faulty harness with the module identified on the Alarm screen.	1) Check accessory power harness to the module for pinched or damaged wires.3
200	Communication_ Failed Sensor in Loop	A break in the communication line between 2 sensors has occurred. There is limited communication between sensors.	1) Check for loose connectors not firmly secured and locked. 2) Check for possible break in pin 2 and pin 3 of communication wires.
201	Loop Communication	Multiple breaks in the communication line between sensors. Loop is not functional.	1) Check for multiple breaks in communication lines in pin 2 and pin 3. 2) Verify there are not multiple loose connections.
202	Loop Communication	Module failure. Loop is functional with limited communication. 1 break in the communication line between 2 sensors has occurred.	1) Check module, Loop A/B harness, and extension harness connections.
203	Loop Communication	Failed module. Multiple breaks in the communication line between module and sensor. Loop is not functional.	1) Check module, Loop A/B harness, and extension harness connections.
204	Loop Communication	Detected a different number of sensors than expected.	1) Configure system with the correct number of sensors on the loop. Check that number of sensors entered on the Loop Setup screen match number of installed sensors.
205	Loop Mismatch	Detected a different number of module loops than expected.	1) Check all module harness connections. May require DICKEY-john Technical Support assistance at 1-800-637-3302.
206	Power Communication	1 break in the power line between 2 sensors. Loop is functional with limited power between sensors.	1) Check all sensors for loose connections.
207	Power Communication	Multiple breaks in the power line between sensors. Loop is not functional. No power is found between sensors.	1) Check all sensors for loose connections.
208	Power Communication	1 break in the power line between module and sensor. Loop is functional with limited power between the module and sensor.	1) Check all sensors and the Loop A/B harness for loose or faulty connections.

OPERATOR'S MANUAL



ALARM #	ALARM	PROBABLE CAUSE	CORRECTIVE ACTION
209	Power Communication	Multiple break in the power line between sensor and module. Loop is not functional with no power between module and sensor.	1) Check module, Loop A/B harness, and extension harness for loose connections.
210	Power Communication	Power test was performed with communication issues found. Power test aborted.	1) Communication errors must be resolved before running Power Test. 2) Check for loose connectors. 3) Loop not configured correctly. Sensors detected but there is an expected mismatch that must be corrected.
300	Seed Sensor(s) Self Test Failure	Sensor failure/lens dirty	1) Check for faulty sensor and replace. 2) Verify lens is free from dirt.
301	Fertilizer Sensor(s) Self Test Failure	Sensor failure/lens dirty	1) Check for faulty sensor and replace. 2) Verify lens is free from dirt.
306	Seed Sensor Low Voltage	Sensor has low voltage	1) Check sensor connections and vehicle charging system.
307	Fertilizer Sensor Low Voltage	Sensor has low voltage	1) Check sensor connections and vehicle charging system.
400	Seed Blockage	Sensor flow is blocked	1) If sensor is not blocked and appears that connections and sensor are OK, decrease the sensitivity reading on the Loop Setup screen. Adjustment to sensitivity could correct.
401	Fertilizer Blockage	Sensor flow is blocked	1) If sensor is not blocked and appears that connections and sensor are OK, decrease the sensitivity reading on the Loop Setup screen. Adjustment to sensitivity could correct.
402	Module Detection Mismatch	Modules expected do not match detected modules. Master module saves the number of members connected on power down. On next power up, if number of modules connected changes, alarm triggers.	1) Check module harness connection for loose or faulty wires.
403	Too Many Modules	System has detected 4 or more modules on the CAN bus.	1) Remove 5th module and harness.
404	Too Many Master Modules	System has detected 2 or more master modules on the CAN bus.	1) Check module harnessing module in and module out connections.
405	Module Intermittent	Module is intermittently losing connection with system.	1) Check harness between modules for loose connection.
406	Module Offline	Module is not communicating and has dropped offline.	1) Check interface harness connections and harness between all modules. 2) Verify terminator is attached to the last module, module out connection.

Dealers have the responsibility of calling to the attention of their customers the following warranty prior to acceptance of an order from their customer for any DICKEY-john product.

DICKEY-john® WARRANTY

DICKEY-john warrants to the original purchaser for use that, if any part of the product proves to be defective in material or workmanship within one year from date of original installation, and is returned to DICKEY-john within 30 days after such defect is discovered, DICKEY-john will (at our option) either replace or repair said part. This warranty does not apply to damage resulting from misuse, neglect, accident, or improper installation or maintenance; any expenses or liability for repairs made by outside parties without DICKEY-john's written consent; damage to any associated equipment; or lost profits or special damages. Said part will not be considered defective if it substantially fulfills the performance expectations. THE FOREGOING WARRANTY IS EXCLUSIVE AND IN LIEU OF ALL OTHER WARRANTIES OF MERCHANTABILITY, FITNESS FOR PURPOSE, AND OF ANY OTHER TYPE, WHETHER EXPRESS OR IMPLIED. DICKEY-john neither assumes nor authorizes anyone to assume for it any other obligation or liability in connection with said part and will not be liable for consequential damages. Purchaser accepts these terms and warranty limitations unless the product is returned within fifteen days for full refund of purchase price.

**For DICKEY-john Service Department, call
1-800-637-3302 in either the U.S.A. or Canada**



Headquarters:

5200 Dickey-john Road, Auburn, IL USA 62615

TEL: 217 438 3371, FAX: 217 438 6012, WEB: www.dickey-john.com

Europe:

DICKEY-john Europe S.A.S, 165, boulevard de Valmy, 92706 – Colombes – France

TEL: 33 (0) 1 41 19 21 80, FAX: 33 (0) 1 47 86 00 07 WEB: www.dickey-john.com