

CONNECTION DIAGRAM

LOOM SOLAR

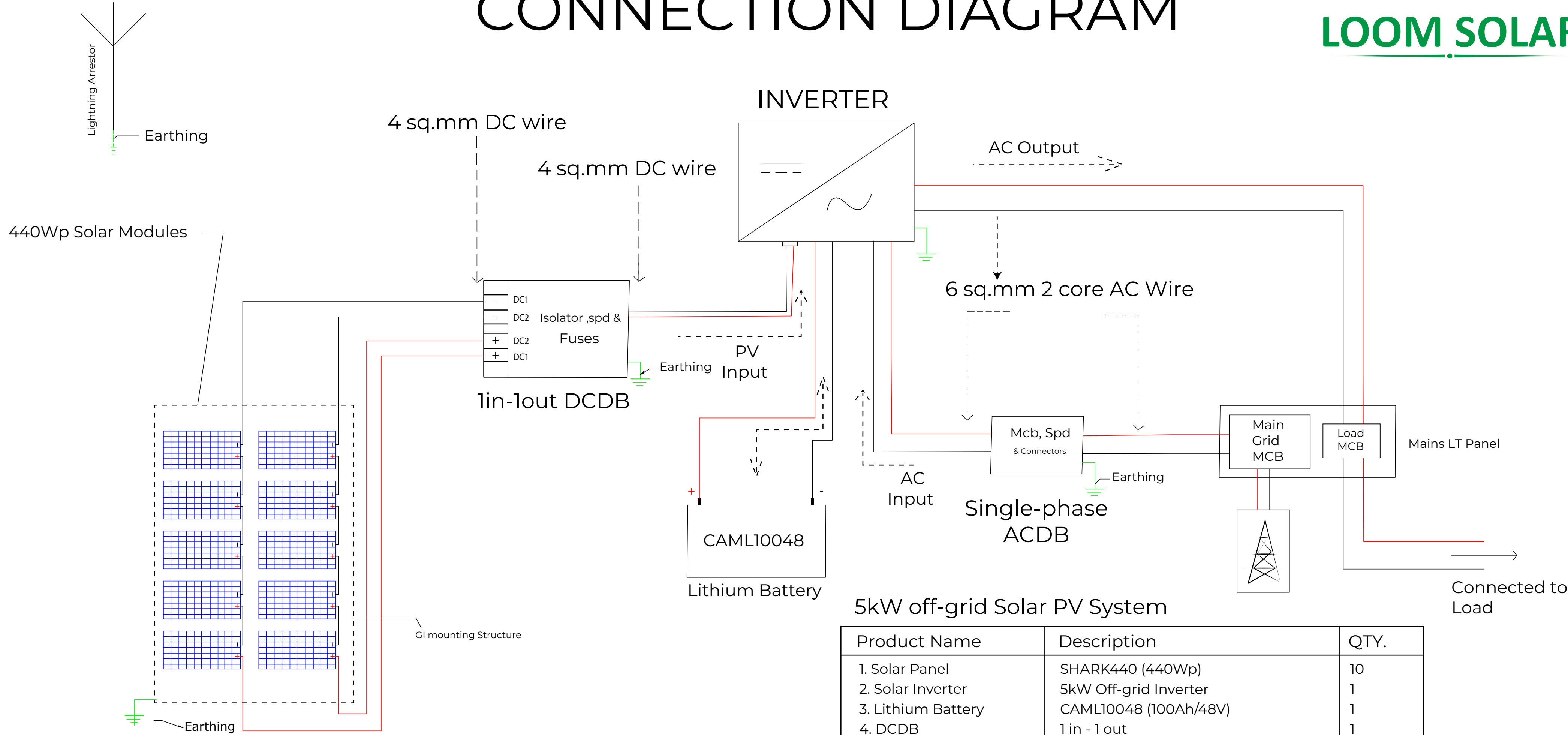

5kW off-grid Solar PV System

| Product Name | Description | QTY. |
|-----------------------|---------------------------------------|-----------|
| 1. Solar Panel | SHARK440 (440Wp) | 10 |
| 2. Solar Inverter | 5kW Off-grid Inverter | 1 |
| 3. Lithium Battery | CAML10048 (100Ah/48V) | 1 |
| 4. DCDB | 1 in - 1 out | 1 |
| 5. ACDB | Single Phase | 1 |
| 6. MC4 Connector | 1 in - 1 out | 2 (Pairs) |
| 7. DC wire | 4 sqmm. DC wire | 30m |
| 8. AC wire | 16 sqmm DC wire (Included in battery) | 1m |
| 8. AC wire | 6 sqmm 2 core AC wire | - |
| 8. Earthing | Component wise | 3 |
| 9. Lightning arrester | 1-meter | 1 |

*wire length may vary as per site requirement