

Hoshizaki America, Inc.

Modular Crescent Cuber Serenity Series

Model
KMS-750MLH



“A Superior Degree
of Reliability”

www.hoshizaki.com

PARTS LIST



Number: 71270
Issued: 4-19-2007

CONTENTS

Auxiliary Codes.....	3
Note About Ordering Parts	3
Material Abbreviations	4
A. Ice Cuber Assembly	5
B. Refrigeration Circuit.....	7
C. Water Circuit.....	11
D. Control Box Assembly	15
E. Switch Box Assembly	17
F. Bin Switch Unit.....	18
G. Label Location.....	19
H. Pump Motor Assembly	20
J. Accessories and Packaging	21

Auxiliary Codes

KMS-750MLH S-0 April 2007

Auxiliary Code Breakdown

K-0

- └─ Designates the year. "K" indicates the year 2000. Years progress or regress in alphabetical order. "J" is 1999, "L" is 2001, "M" is 2002, and so on. The letters "I" and "O" were skipped.
- └─ Designates significant part changes within the same year for this model. Base is 0 and this number advances for each change.

Example: P-1

- └─ "P" indicates 2004.
- └─ "1" indicates the first significant part change for 2004.

Note About Ordering Parts

Most assemblies cannot be ordered as complete units; parts in the assemblies generally must be ordered separately.

Material Abbreviations

ALUMINUM

AL = Aluminum

COPPER

CU = Copper

PLASTIC

ABS = Acrylonitrile -butadiene - styrene
AC = Polyacetal
EVA = Ethylene vinyl acetate
PA = Polyamide = Nylon
PC = Polycarbonate
PE = Polyethylene
PES = Polyester
PETP = Polyethylene terephthalate = Tetlon
PP = Polypropylene
PS = Polystyrene
PTFE = Polytetrafluoroethylene = Teflon
PUR = Polyurethane
PVC = Polyvinyl chloride

RUBBER

VN = Vinyl Nitrile
EPDM = EP rubber
NBR = Nitrile butadiene rubber
NR = Natural rubber
NP = Neoprene
SI.R = Silicone rubber
SY.R = Synthetic rubber
EPH = Epichlorohydrin

STEEL

GS = Galvanized steel
SS = Stainless steel
PS = Plated steel
PAS = Primed steel

A. Ice Cuber Assembly
KMS-750MLH
 S-0

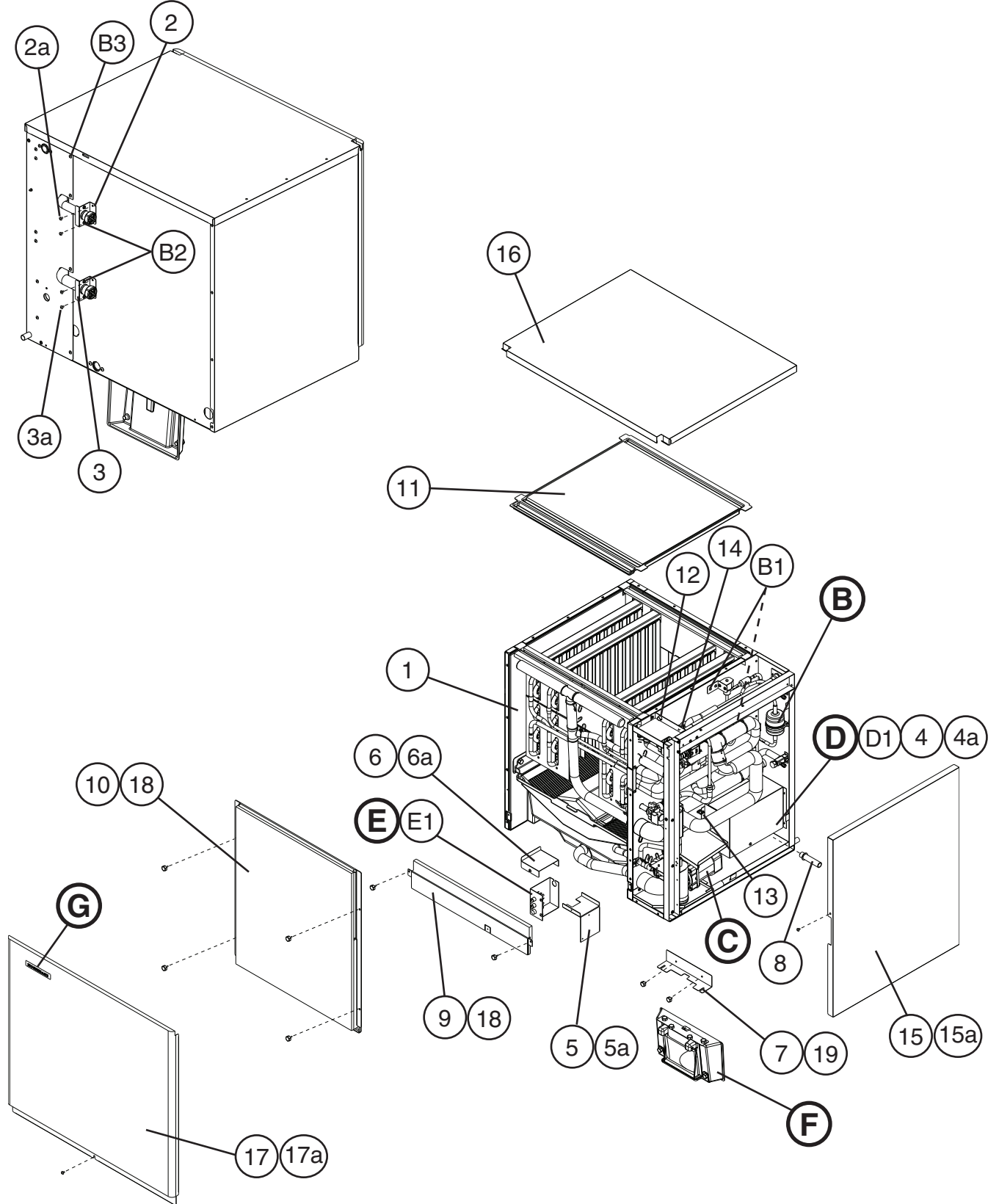

Title: **A. Ice Cuber Assembly** Model: **KMS-750MLH**

Index No.	Description	Material or Model Number	Part Number	Required Number									
				S-0									
B	Refrigeration Circuit	-	1A1359A01	1									
B1	T2 Screw	4x8, SS	7P32-0408	4									
B2	Truss Head Screw	4x8, SS	7C32-0408	4									
B3	T2 Screw	4x8, SS	7P32-0408	6									
C	Water Circuit	-	1A1357A01	1									
D	Control Box Assembly	-	3A3247A01	1									
D1	T2 Screw	4x8, SS	7P32-0408	4									
E	Switch Box Assembly	-	4A3540A01	1									
E1	T2 Screw	4x8, SS	7P32-0408	2									
F	Bin Switch Unit (bin control)	-	3A3249A01	1									
G	Label Location	-	2A4217A01	1									
1	Evaporator Case	-	1A0971G01	1									
2	Bracket / Coupling	GS	4A3891-02	1									
2a	T2 Screw	4x8, SS	7P32-0408	2									
3	Bracket / Coupling	GS	4A3891-02	1									
3a	T2 Screw	4x8, SS	7P32-0408	2									
4	Control Box Cover	GS	3A3248-01	1									
4a	T2 Screw	4x8, SS	7P32-0408	1									
5	Switch Box - Bracket	GS	3A3304-01	1									
5a	Truss Head Screw	4x8, SS	7C32-0408	2									
6	Switch Box - Cover	GS	4A3623-01	1									
6a	T2 Screw	4x8, SS	7P32-0408	1									
7	Switch Bracket (bin control)	SS	4A3541-01	1									
8	Pipe (B) - Evaporator Case	-	4A3525-01	1									
9	Front Frame	-	4A3542G01	1									
10	Front Insulation	-	3A3250G01	1									
11	Top Insulation	-	3A3251G01	1									
12	Bushing	OCB-625	428394-03	1									
13	Wire Saddle	-	4A0338-02	5									
14	Wire Saddle	-	4A0338-01	3									
15	Side Panel (R)	SS	2A3225G01	1									
15a	Truss Head Screw	4x8, SS	7C32-0408	1									
16	Top Panel	SS	2A3226-01	1									
17	Front Panel	SS	2A3236-01	1									
17a	Truss Head Screw	4x12, SS	7C32-0412	1									
18	Thumbscrew	ABS, SS	415949G10	6									
19	Thumbscrew	ABS, SS	415949G08	2									

B. Refrigeration Circuit

1/2

KMS-750MLH

S-0

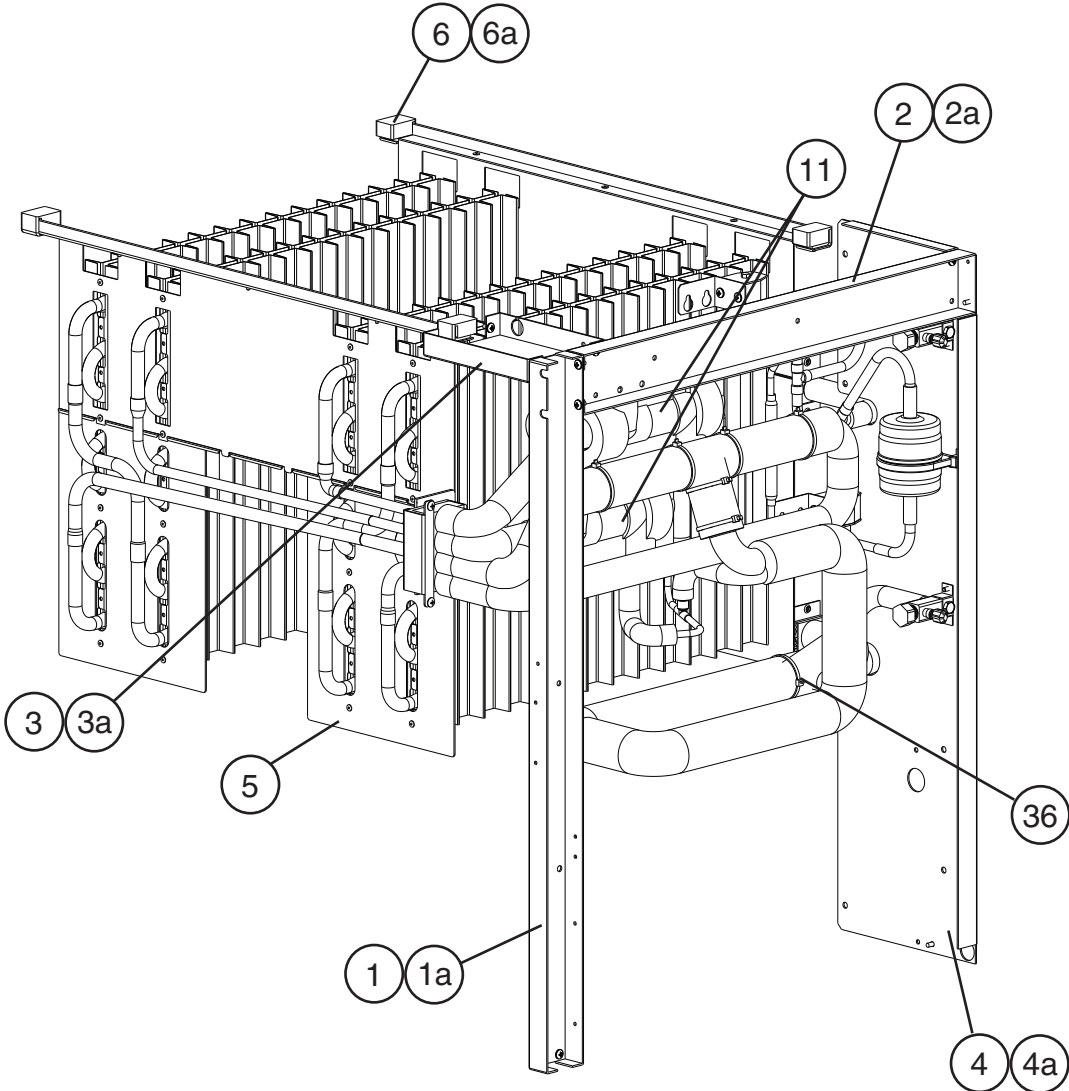

B. Refrigeration Circuit

2/2

KMS-750MLH

S-0

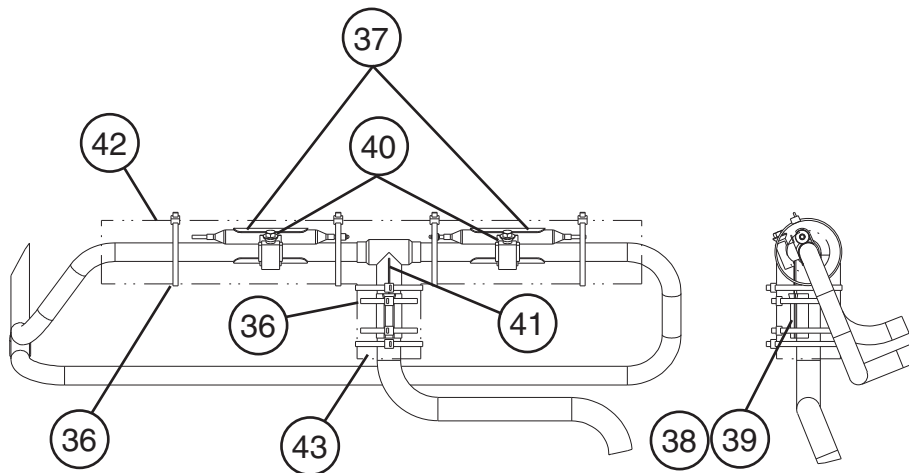
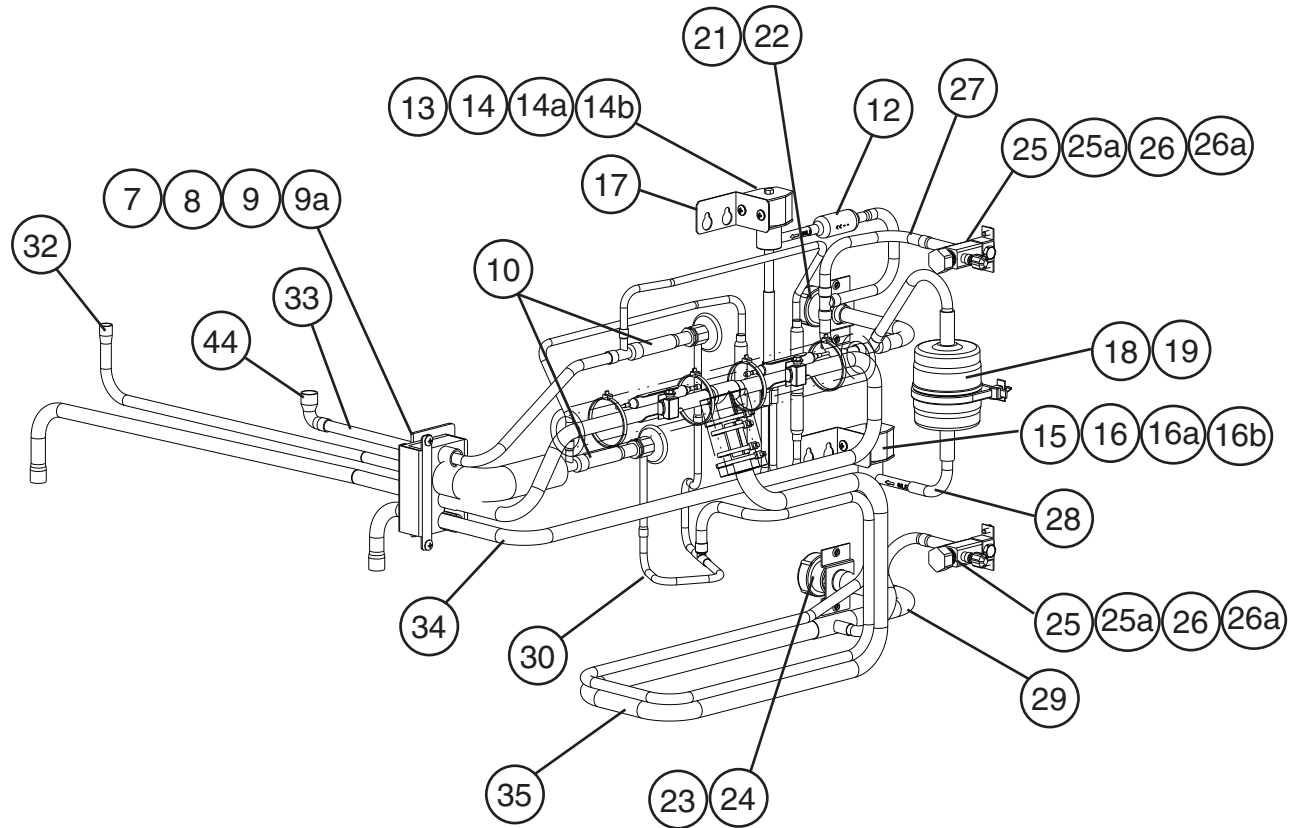

Detailed Thermistor and TXV Bulb Attachment

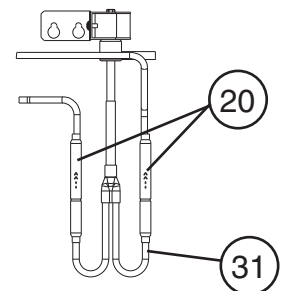

Detailed Check Valve Attachment

Title: B. Refrigeration Circuit Model: KMS-750MLH											
Index No.	Description	Material or Model Number	Part Number	Required Number							
				S-0							
1	Side Frame (A)	GS	2A3230-01	1							
1a	Truss Head Screw	4x8, SS	7C32-0408	4							
2	Side Frame (B)	GS	3A3256-01	1							
2a	Truss Head Screw	4x8, SS	7C32-0408	2							
3	Front Frame	GS	3A3257-01	1							
3a	Truss Head Screw	4x8, SS	7C32-0408	4							
4	Rear Panel	GS; See A. Ice Cuber Assembly, item B3 for additional mounting screws	2A3231-01	1							
4a	Truss Head Screw	4x8, SS	7C32-0408	1							
5	Evaporator	-	2A4196G01	1							
6	Frame Seal	EPDM	323925-01	4							
6a	Truss Head Screw	4x8, SS	7C32-0408	4							
7	Rubber Tube (A)	-	323974-01	1							
8	Insulation	-	436597-01	1							
9	Insulation Holder	SS	3A0979-01	1							
9a	T2 Screw	4x8, SS	7P32-0408	2							
10	Expansion Valve	-	4A1414-01	2							
11	Expansion Valve Cover	-	3A0944-01	2							
12	Strainer	-	441569-02	1							
13	Valve Body - Hot Gas	-	4A3978-01	1							
14	Coil - Valve	-	4A3277-01	1							
14a	Bolt	-	4A3277F01	1							
14b	Truss Head Screw	4x8, SS	7C32-0408	2							
15	Valve Body - Line	-	4A3276-01	1							
16	Coil - Valve	-	4A3277-01	1							
16a	Bolt	-	4A3277F01	1							
16b	Truss Head Screw	4x8, SS	7C32-0408	2							
17	Bracket / Coil	GS; See A. Ice Cuber Assembly, item B1 for mounting screws	4A3890-01	2							
18	Drier	-	4A2663-01	1							
19	Nylon Tie	PLWP3H-TL	8911-0301	1							
20	Check Valve	-	4A1373-01	2							
21	Coupling (male)	5782-8-10	434072-01	1							
22	Tube Holder - L (liquid line)	GS; See A. Ice Cuber Assembly, item B2 for mounting screws	438245-01	1							

Title: B. Refrigeration Circuit Model: KMS-750MLH												
Index No.	Description	Material or Model Number	Part Number	Required Number								
				S-0								
23	Coupling (male)	5782-10-11	4A3826-01	1								
24	Tube Holder - L (suction line)	GS; See A. Ice Cuber Assembly, item B2 for mounting screws	438245-02	1								
25	Service Valve	-	4A3420-01	2								
25a	Hex Head Tapping Screw	1/4x20x1/2	7B0311412	2								
26	Bracket - Service Valve	GS	4A3892-01	2								
26a	T2 Screw	4x8, SS	7P32-0408	4								
27	Copper Tube (A)	-	3A3258G01	1								
28	Copper Tube (B)	-	4A3555-01	1								
29	Copper Tube (C)	-	3A3299G01	1								
30	Copper Tube (D)	-	3A3259G01	1								
31	Copper Tube (E)	-	4A3556G01	1								
32	Copper Tube (F)	-	3A4421G01	1								
33	Copper Tube (G)	-	3A4422G01	1								
34	Copper Tube (J)	-	3A3262G01	1								
35	Heat Exchanger	-	3A3263G01	1								
36	Cable Tie	-	8911-0200	10								
37	Holder - Expansion Valve	-	3A0107-01	2								
38	Holder Thermistor	COPPER	438247-01	1								
39	Insulation - Thermistor	-	427441-01	1								
40	Hose Clamp	No. 6806	443461-02	2								
41	Thermistor	-	429006-05	1								
42	Insulation Tubing	L=365	7762-2943	1								
43	Insulation Tubing	L=70	7762-2943	1								
44	Elbow	-	4A1059-01	1								

C. Water Circuit
1/2
KMS-750MLH
S-0

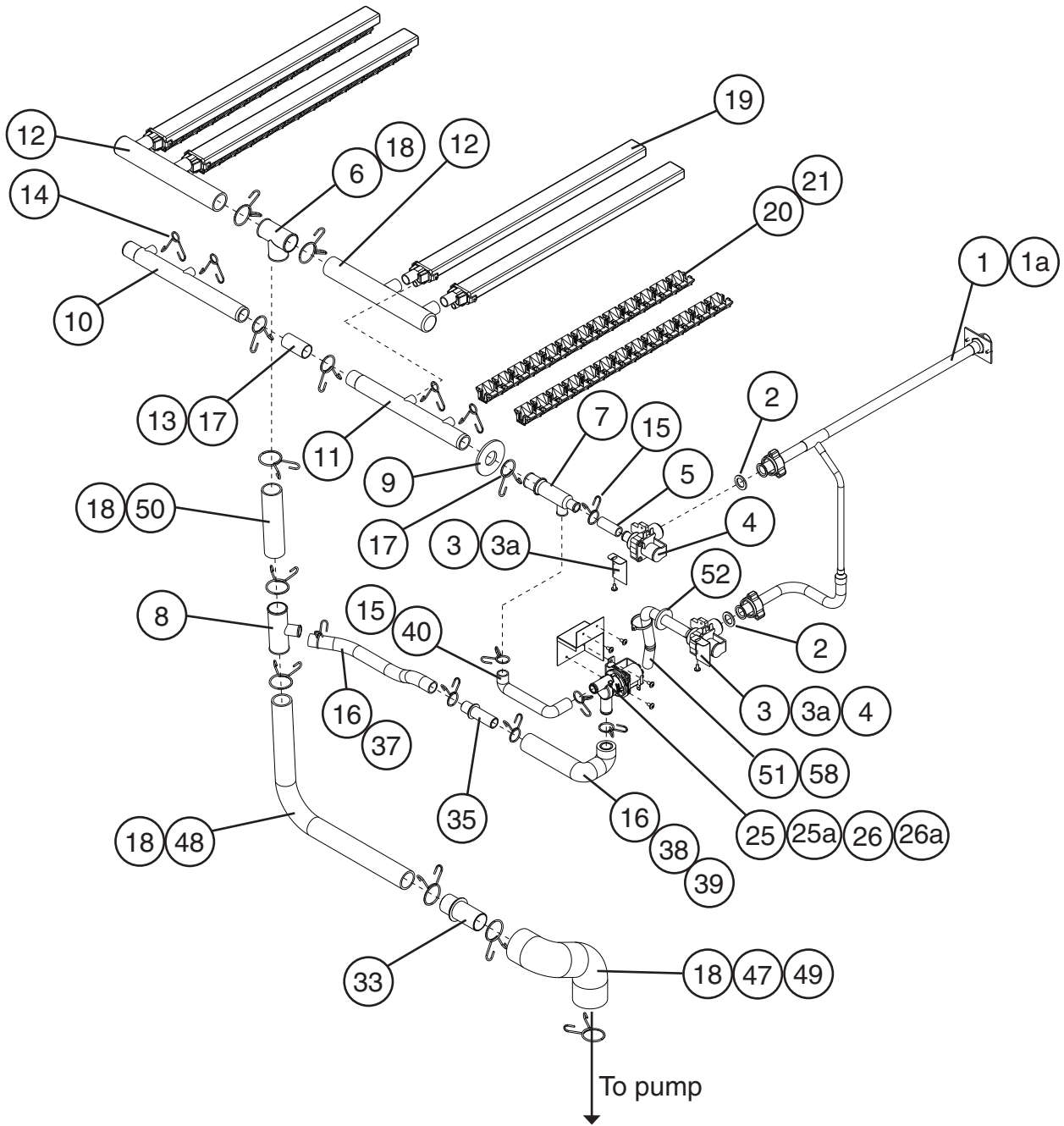

C. Water Circuit
2/2
KMS-750MLH
S-0

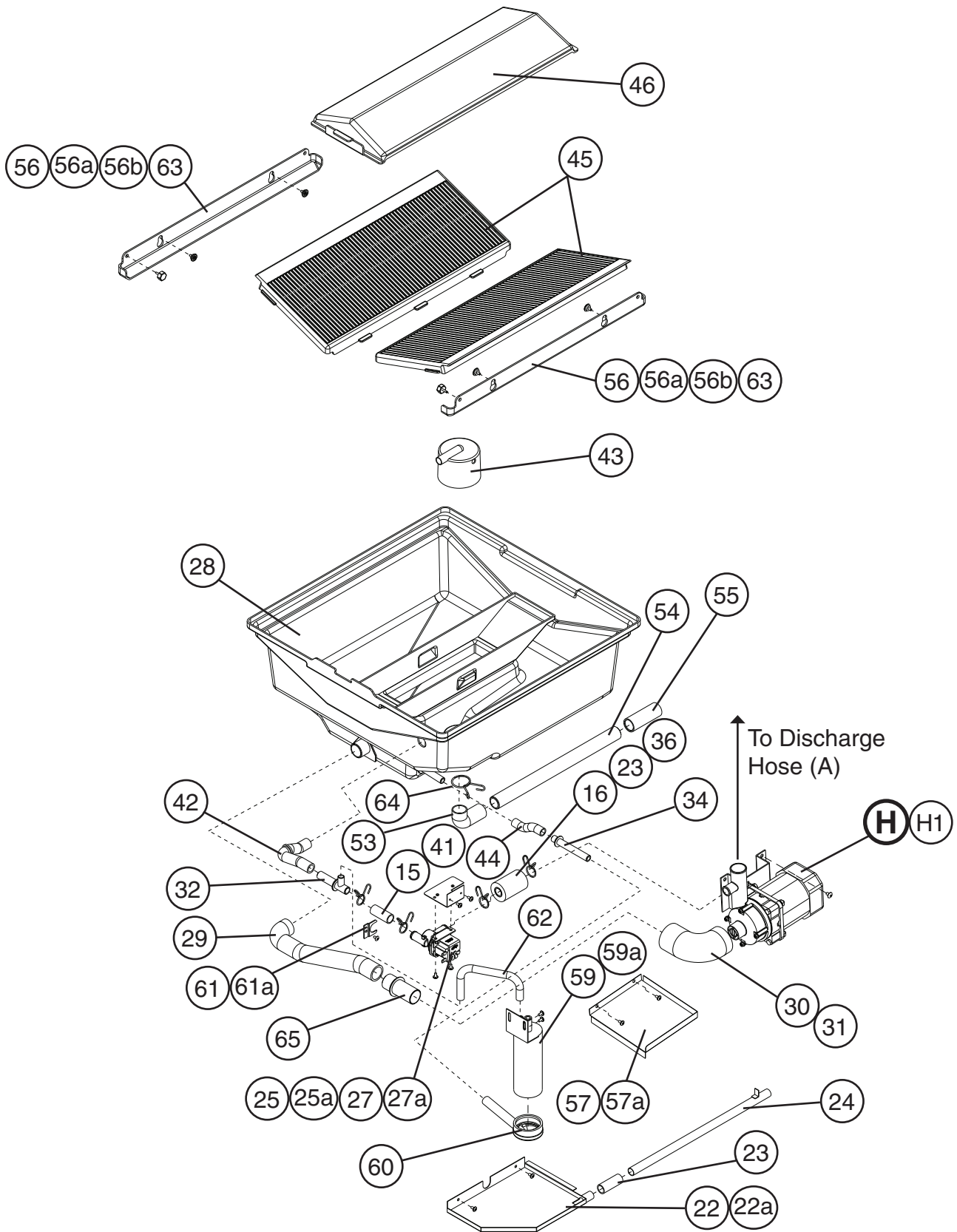

Title: **C. Water Circuit** Model: **KMS-750MLH**

Index No.	Description	Material or Model Number	Part Number	Required Number																
				S-0																
H	Pump Motor Assembly	HS-0205	2A3237A02	1																
H1	Truss Head Screw	5x8, SS	7C32-0508	2																
1	Water Supply Pipe	-	3A3273G01	1																
1a	T2 Screw	4x8, SS	7P32-0408	2																
2	Rubber Gasket	-	413854-03	2																
3	Water Valve Bracket	GS	3A3274-01	2																
3a	Truss Head Screw	4x8, SS	7C32-0408	2																
4	Water Valve (harvest & fill)	J248-032	3U0111-02	2																
5	Vinyl Hose	L=40	7716-1216	1																
6	Distributor (A)	-	4A3528-01	1																
7	Distributor (B)	-	3A3239-01	1																
8	Distributor (C)	-	4A3530-01	1																
9	Flange	-	439267-02	1																
10	Distributor Hose (A)	-	3A4409-01	1																
11	Distributor Hose (B)	-	3A4409-02	1																
12	Distributor Hose (C)	-	3A4410-01	2																
13	Joint Pipe	-	439297-02	1																
14	Hose Clamp	13.5 mm, SS	427443-07	4																
15	Hose Clamp	18 mm, SS	427443-05	5																
16	Hose Clamp	20 mm, SS	427443-06	6																
17	Hose Clamp	25 mm, SS	427443-03	3																
18	Hose Clamp	32 mm, SS	427443-09	8																
19	Spray Tube	-	437049G04	4																
20	Spray Guide (A)	5 cups	208586-01	8																
21	Spray Guide (D)	3 cups	208586-04	4																
22	Pump - Drain Pan	SS	3A3275G01	1																
22a	Truss Head Screw	4x8, SS	7C32-0408	2																
23	Vinyl Hose	L=50	7716-1519	2																
24	Drain Pipe	SS	4A3568G01	1																
25	Water Valve (wash & drain)	-	4A3722-01	2																
25a	Truss Head Screw	4x8, SS	7C32-0408	4																
26	Drain Valve Bracket (A)	GS	4A3569-01	1																
26a	Truss Head Screw	4x8, SS	7C32-0408	2																
27	Drain Valve Bracket (B)	GS	4A3570-01	1																
27a	Truss Head Screw	4x8, SS	7C32-0408	2																
28	Tank	-	1A1146G01	1																
29	Suction Hose (A)	-	3A3234-01	1																
30	Suction Hose (B)	-	4A3534-01	1																
31	Insulation Tubing	L=125	7762-3555	1																
32	Pipe (A) - Evaporator Case	-	4A3524-01	1																
33	Pipe (C) - Evaporator Case	-	4A3526-01	1																
34	Pipe (D) - Evaporator Case	-	4A3527-01	1																
35	Pipe (E) - Evaporator Case	-	4A3765-01	1																
36	Insulation Tubing	L=60	7762-2040	1																

Title: **C. Water Circuit** Model: **KMS-750MLH**

Index No.	Description	Material or Model Number	Part Number	Required Number									
				S-0									
37	Vinyl Hose	L=320	7716-1519	1									
38	Hose - Inlet	-	3A3496-01	1									
39	Insulation Tubing	L=200	7762-2030	1									
40	Hose - Outlet	-	3A3497-01	1									
41	Vinyl Hose	L=45	7716-1519	1									
42	Drain Hose (to overflow cap)	-	4A3536-01	1									
43	Overflow Cap	-	2A3215-01	1									
44	Vinyl Hose	L=80	7716-1216	1									
45	Cube Guide	-	1A0966-01	2									
46	Separator - Tank	-	2A3220-01	1									
47	Discharge Hose (A)	-	4A3532-01	1									
48	Discharge Hose (B)	-	4A3533-01	1									
49	Insulation Tubing	L=230	7762-3555	1									
50	Vinyl Hose	L=124	7716-2732	1									
51	Inlet Hose	-	4A3535-01	1									
52	Flange	-	4A3573-01	1									
53	Drain Hose	-	4A3537-01	1									
54	PVC Pipe	-	433509-03	1									
55	Drain Hose	-	434808-01	1									
56	Side Separator	-	3A3235-01	2									
56a	Collar	ABS	435269-01	4									
56b	Flat Head T2 Screw	4x12, SS	7P22-0412	4									
57	Motor Cover	GS	4A3586-01	1									
57a	Truss Head Screw	4x8, SS	7C32-0408	2									
58	Cable Tie	-	8911-0200	1									
59	Float Switch	-	468264-01	1									
59a	Truss Head Screw	4x8, SS	7C32-0408	2									
60	Connector - Float Switch	-	3A4169-01	1									
61	Pipe Stopper	GS	4A3767-01	1									
61a	T2 Screw	4x8, SS	7P32-0408	1									
62	Hose - Float	-	4A3766-01	1									
63	Thumbscrew	-	415949G10	2									
64	Hose Clamp	27 mm, SS	427443-08	1									
65	Pipe (F) - Evaporator Case	-	4A4294-01	1									

D. Control Box Assembly
KMS-750MLH
 S-0

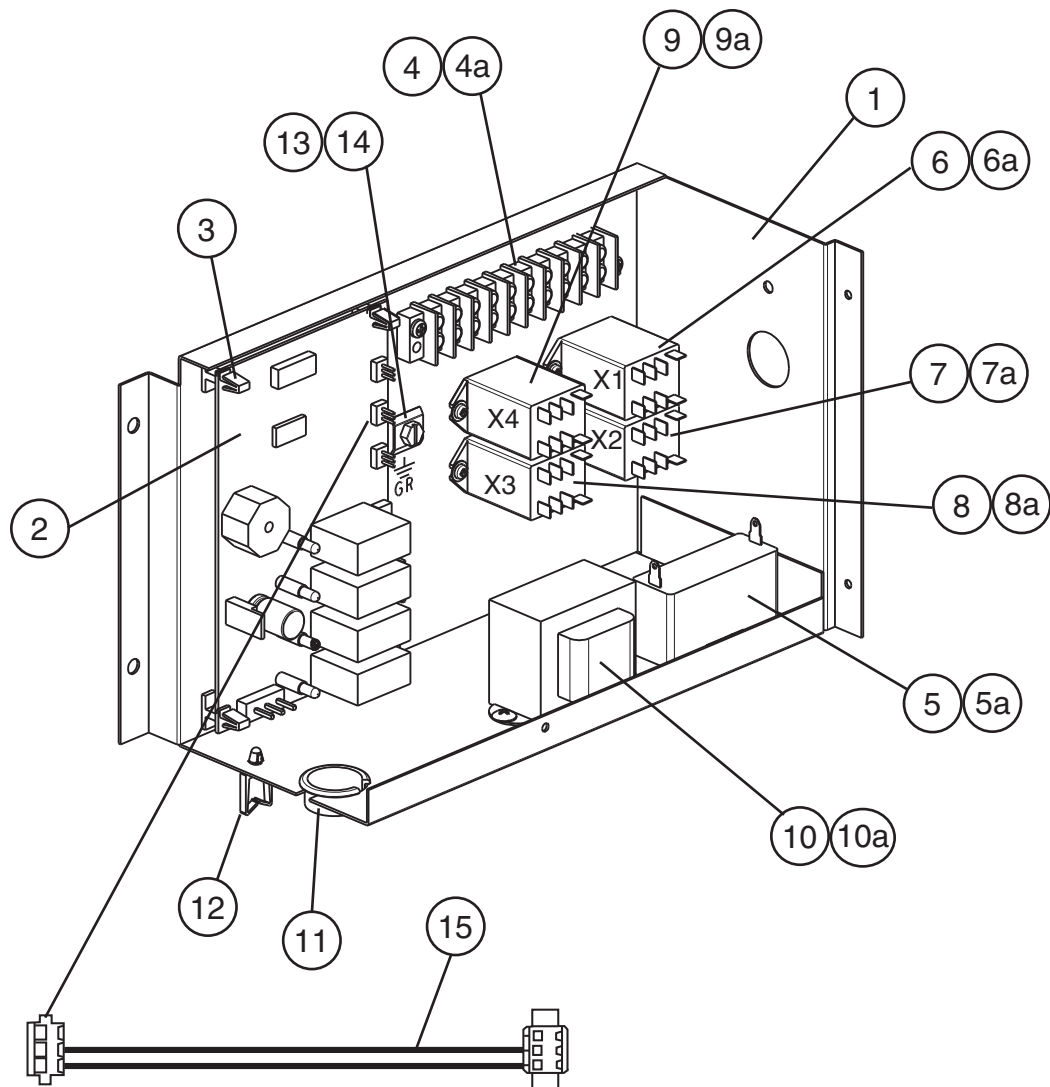

Title: D. Control Box Assembly Model: KMS-750MLH					Required Number								
Index No.	Description	Material or Model Number	Part Number	S-0									
1	Control Box	GS	2A3234-01	1									
2	Control Board	-	2A3792-01	1									
3	Board Support	CBLS37-M	4A0336-03	4									
4	Terminal Block	-	4A4201-01	1									
4a	Pan Head Screw	4x12 SS	7C12-0412	2									
5	Capacitor (pump)	10.0MFD, 250V	443192-01	1									
5a	T2 Screw	4x10 SS	7P32-0410	1									

Title: **D. Control Box Assembly** Model: **KMS-750MLH**

Index No.	Description	Material or Model Number	Part Number	Required Number									
				S-0									
6	Relay - X1 Harvest Water Valve	LY2F AC120V	406132-07	1									
6a	Tapping Screw	3x8	431415-01	2									
7	Relay - X2 Pump Out - Pump Motor & Drain Water Valve	LY2F AC120V	406132-07	1									
7a	Tapping Screw	3x8	431415-01	2									
8	Relay - X3 Drain Water Valve Cut-out	LY2F AC120V	406132-07	1									
8a	Tapping Screw	3x8	431415-01	2									
9	Relay - X4 Pump Out - Drain Water Valve Cut-in	LY2F AC120V	406132-07	1									
9a	Tapping Screw	3x8	431415-01	2									
10	Transformer	-	3A0172-01	1									
10a	T2 Screw	4x8 SS	7P32-0408	2									
11	Bushing	OCB-1000	428394-05	1									
12	Wire Saddle	-	4A0338-02	1									
13	Square Washer	BRASS	433537-02	1									
14	Screw - Grounding	5x8	433304-02	1									
15	Wire Harness (bin control)	L=90	4A2200G04	1									

E. Switch Box Assembly
KMS-750MLH
 S-0

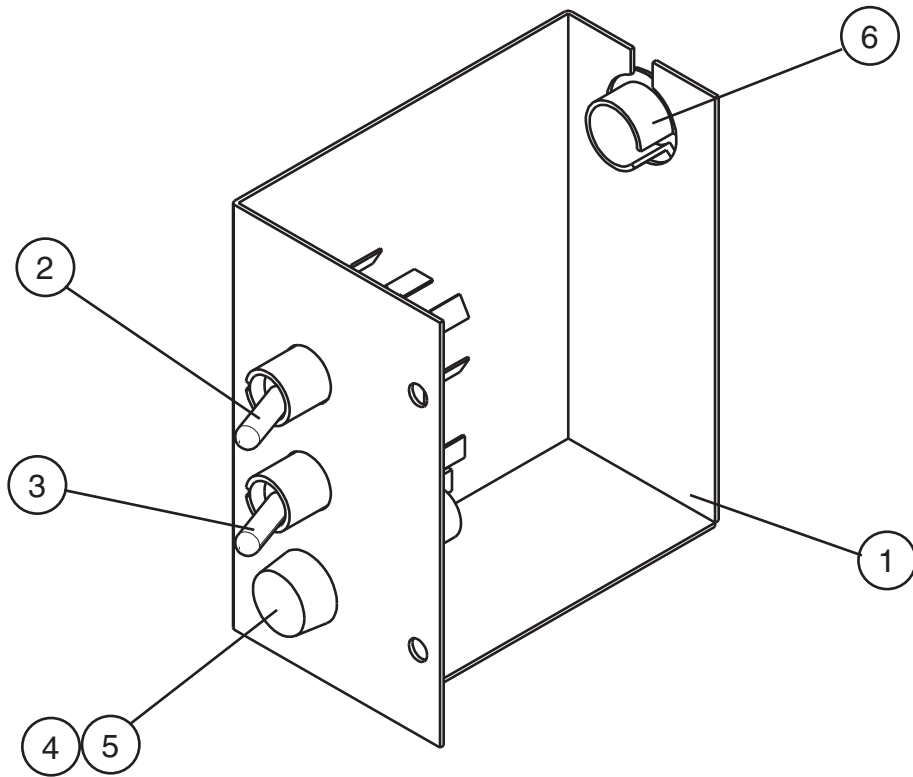

Title: E. Switch Box Assembly Model: KMS-750MLH										
Index No.	Description	Material or Model Number	Part Number	Required Number						
				S-0						
1	Switch Box	GS	3A3277-01	1						
2	Toggle Switch (control)	-	443119-01	1						
3	Toggle Switch (service)	-	4A0985-01	1						
4	Fuse Holder	HTB82I 1/4 × 1-1/4	4A3449-01	1						
5	Fuse	AGC-10 250V 10A	4A0893-07	2						
6	Bushing	OCB-750	428394-01	1						

F. Bin Switch Unit
KMS-750MLH
 S-0

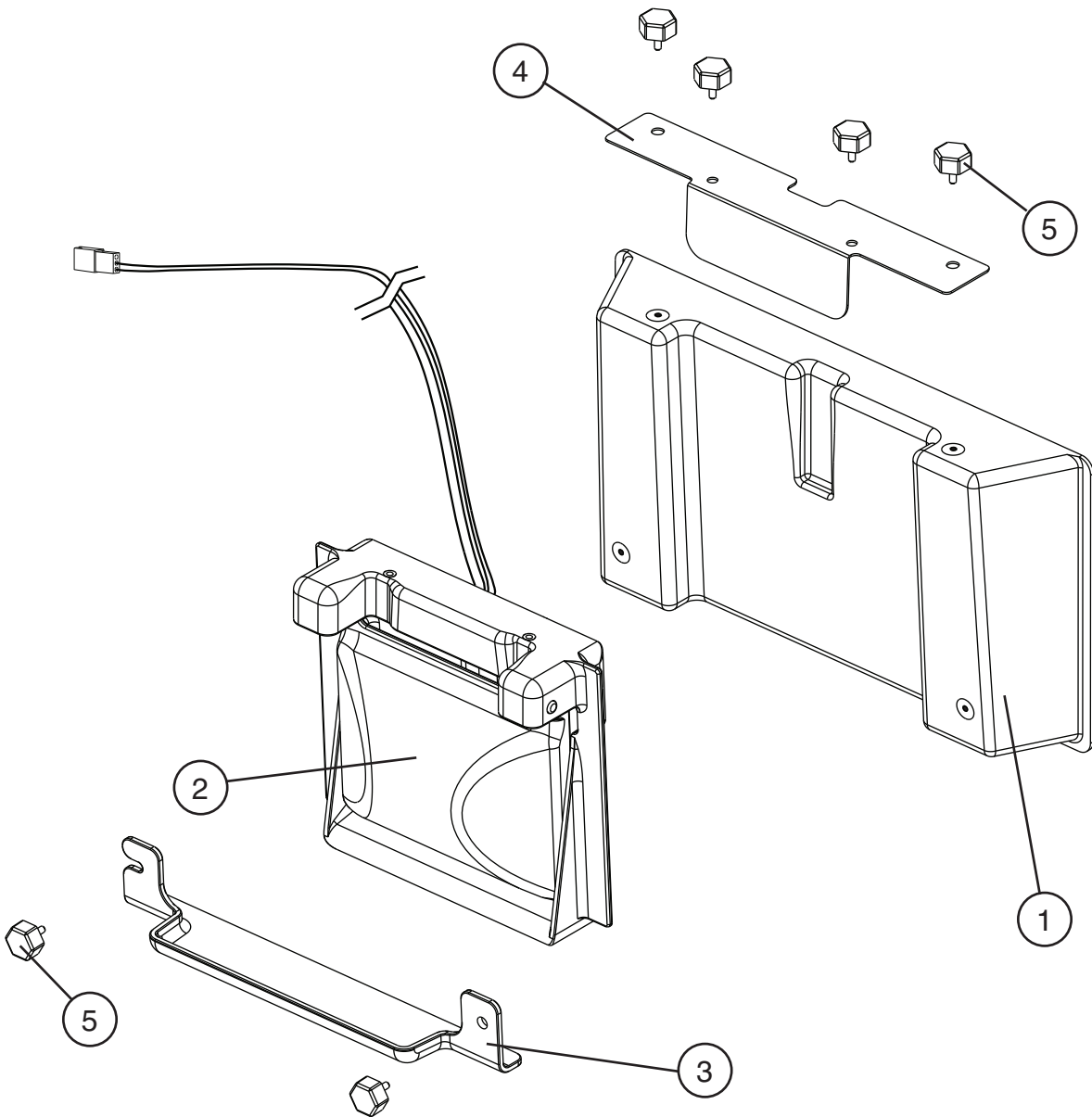

Title: F. Bin Switch Unit Model: KMS-750MLH					Required Number								
Index No.	Description	Material or Model Number	Part Number	S-0									
1	Mount - Bin Switch	-	3A3278G01	1									
2	Bin Control	-	464574-01	1									
3	Switch Guide	-	3A2643-01	1									
4	Switch Cover	SS	4A3580-01	1									
5	Thumbscrew - Black	-	415949G08	6									

G. Label Location
KMS-750MLH
 S-0

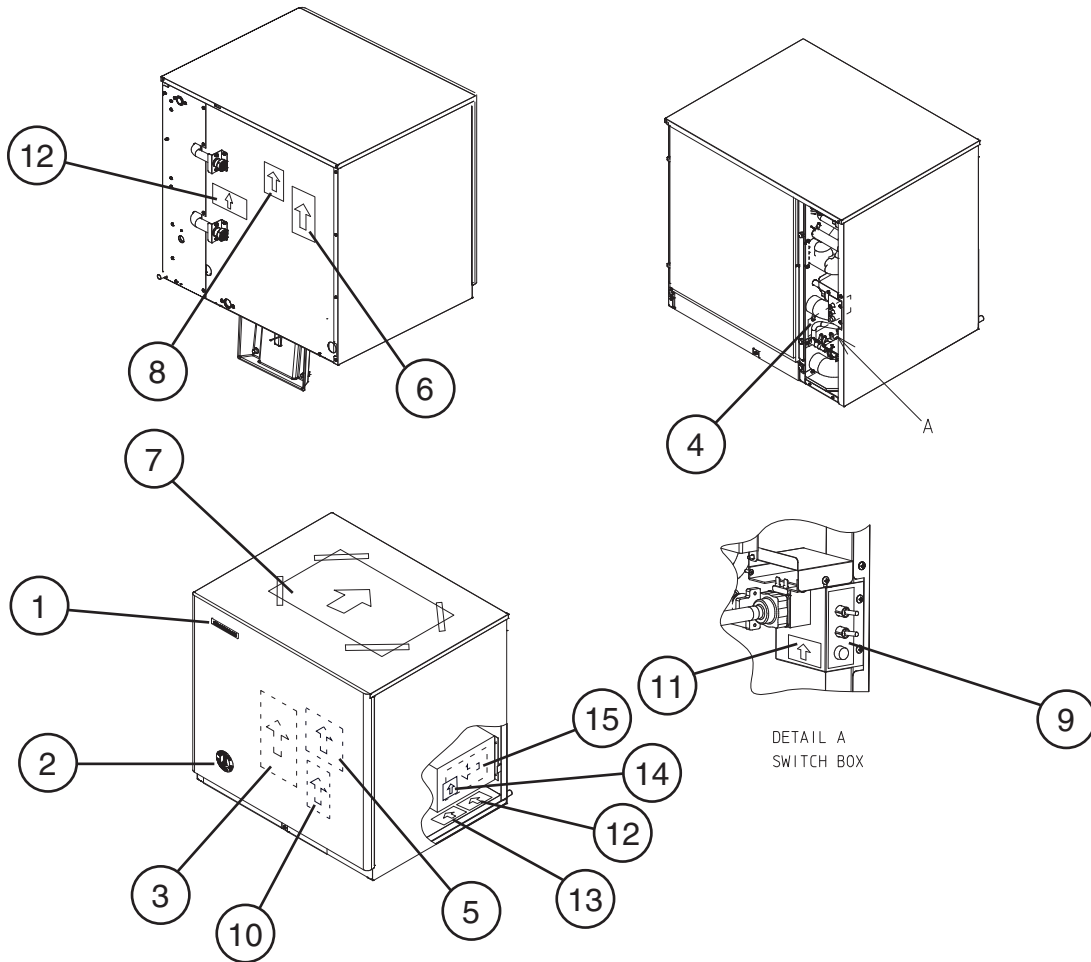

Title: G. Label Location Model: KMS-750MLH														
Index No.	Description	Material or Model Number	Part Number	Required Number										
				S-0										
1	Emblem	-	4A0560-01	1										
2	Label - Penguin - HA (R)	-	4A0526-01	1										
3	Maintenance Label	-	2A3296-01	1										
4	Caution Label (K)	-	439150-01	1										
5	Wiring Label	-	2A4197-01	1										
6	Nameplate	-	2A3298-02	1										
7	Instruction Sheet	-	2A3299-01	1										
8	Instruction Label	-	444575-01	1										
9	Manual Label	-	3A3331-01	1										
10	Rating Label	-	2A3300-02	1										
11	Label - Fuse	-	4A2817-01	1										
12	Label - 404A	-	4A0960-01	2										
13	Caution Label	-	4A4209-01	1										
14	Label - Alarm	-	4A3517-01	1										
15	Label - Control Board	-	3A3444-01	1										

H. Pump Motor Assembly

KMS-750MLH

S-0

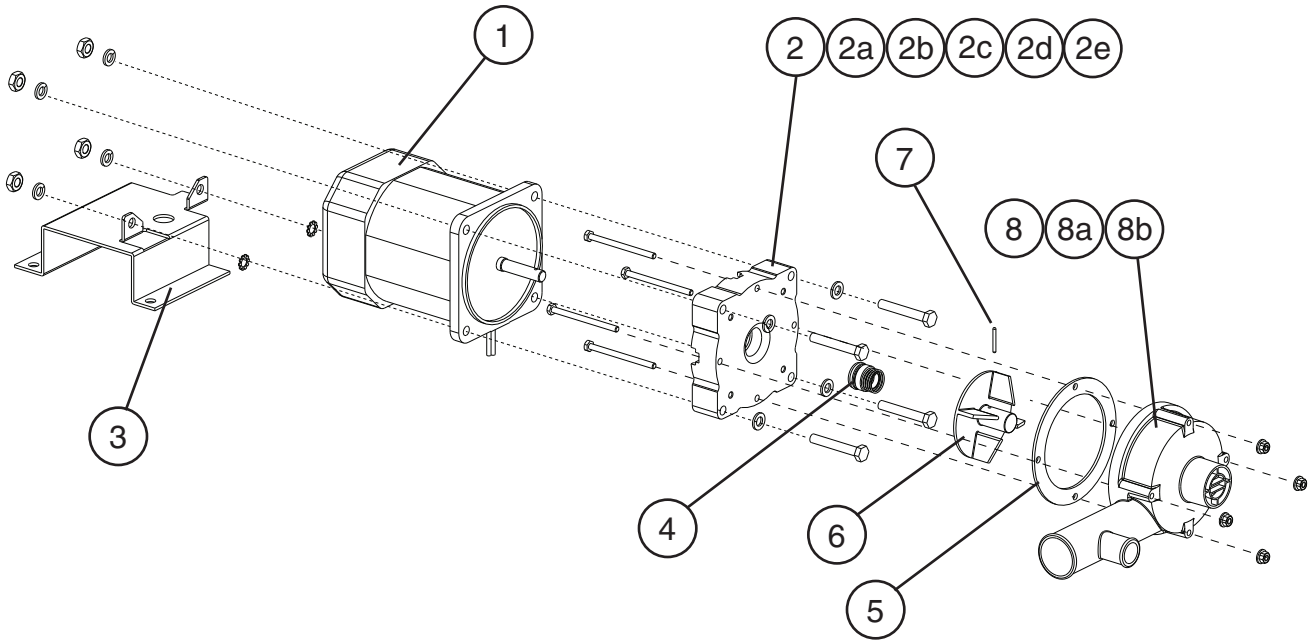

Title: H. Pump Motor Assembly Model: KMS-750MLH													
Index No.	Description	Material or Model Number	Part Number	Required Number									
				S-0									
1	Pump Motor	M91A60SP201	2U0106-01	1									
2	Pump Flange	-	215662-01	1									
2a	Hex Bolt	6x40, SS	7B02-0640	4									
2b	Flat Washer	M6, SS	7W22-0600	4									
2c	Tooth Washer	M6, SS	7R22-0600	2									
2d	Split Lock Washer	M6, SS	7L22-0600	4									
2e	Hex Nut	M6, SS	7N12-0600	4									
3	Pump Motor Bracket	SS	3A3252-01	1									
4	Mechanical Seal	-	4A3820-01	1									
5	Packing	NSF	428547-01	1									
6	Impeller	ABS	428548-01	1									
7	Pin	-	4A0648-01	1									
8	Pump Housing	-	2A3214-01	1									
8a	Hex Bolt	4x55, SS	7B02-0455	4									
8b	Hex Flange Nut	4, SS	7J02-0400	4									

J. Accessories and Packaging
KMS-750MLH
 S-0

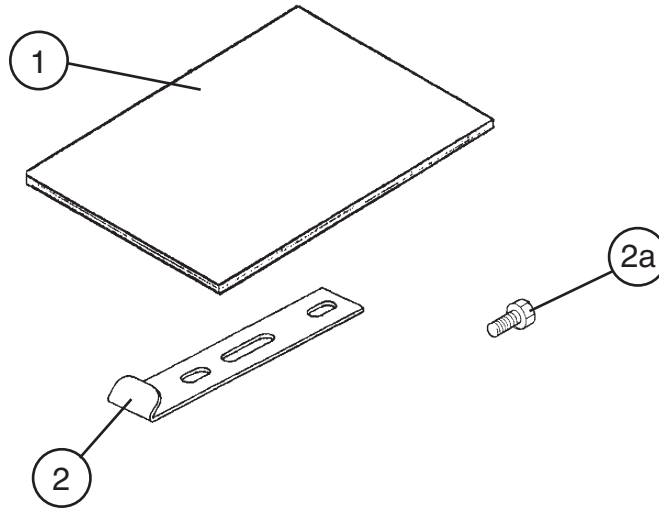

Title: J. Accessories and Packaging Model: KMS-750MLH										
Index No.	Description	Material or Model Number	Part Number	Required Number						
				S-0						
1	Instruction Manual	-	91A1YC10A	1						
2	Universal Brace	GS	4A0363-01	1						
2a	Hex Bolt	5x12 SS	7B02-0512	1						
Packaging			2A4083A01							
1	Pallet	-	2A3684-04	1						
2	Tray Assembly - Bottom	-	1A1223G04	1						
3	Corner Post	-	3A4040-06	3						
4	Tray Assembly - Top	-	1A1222G04	1						
5	Carton	-	2A3862-41	1						
6	Plastic Support	-	2A3865-09	4						
7	Corner Post	-	3A4040-07	1						
8	Post Support	-	4A4211-01	1						