



HOSHIZAKI

Parts List

Stackable Crescent Cuber

Models

KM-2400SRF3

KM-2400SRH3



hoshizakiamerica.com

Number: 71162
Issued: 1-7-2000
Revised: 11-18-2016

CONTENTS

Auxiliary Codes.....	3
Note About Ordering Parts	3
A. Main Assembly & Refrigeration Circuit	4
B. Water Circuit	8
C. Control Box Assembly	11
D. Accessories & Labels	12

Auxiliary Codes

KM-2400SRF3

J-0 September 1999
K-0 January 2000

KM-2400SRH3

L-0 December 2000
M-0 December 2001
M-1 March 2002
M-2 May 2002
N-0 December 2002
N-1 March 2003
N-2 May 2003
P-0 December 2003
Q-0 December 2004
Q-1 November 2005
R-0 December 2005
R-1 August 2006
S-0 January 2007
S-1 February 2007
T-0 January 2008
T-1 June 2008
U-0 January 2009

Auxiliary Code Breakdown

The auxiliary code is the first two characters in the serial number. The first character indicates the year. Years progress or regress in alphabetical order. The series runs from "A" through "V" and the letters "I" and "O" are skipped. The second character indicates significant part changes within a year. Base is "0" and this number advances for each change. In cases where there is a letter in parentheses, this designates the month. This is the last character in the serial number. The series runs from "(A)" through "(M)" and the letter "(I)" is skipped. This designation is only included when identifying a parts change within an auxiliary code.

Note About Ordering Parts

Most assemblies cannot be ordered as complete units; parts in the assemblies generally must be ordered separately.

A. Main Assembly & Refrigeration Circuit

KM-2400SRF3, KM-2400SRH3

1/2

J-0 to U-0

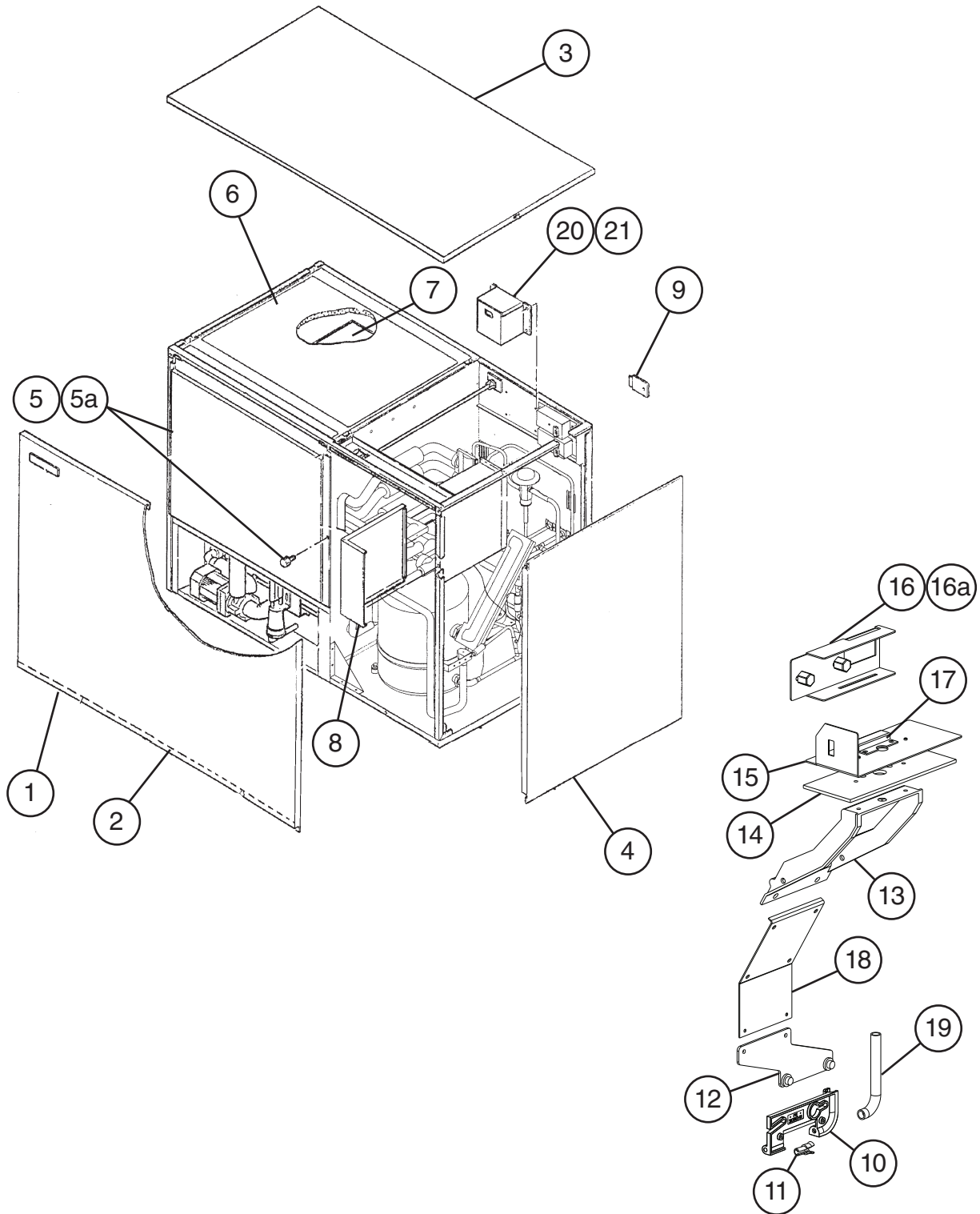

Item 18 is for use with Hoshizaki bins B-1300, B-1500, B-1650, and non-Hoshizaki bins.

A. Main Assembly & Refrigeration Circuit KM-2400SRF3, KM-2400SRH3

2/2

J-0 to U-0

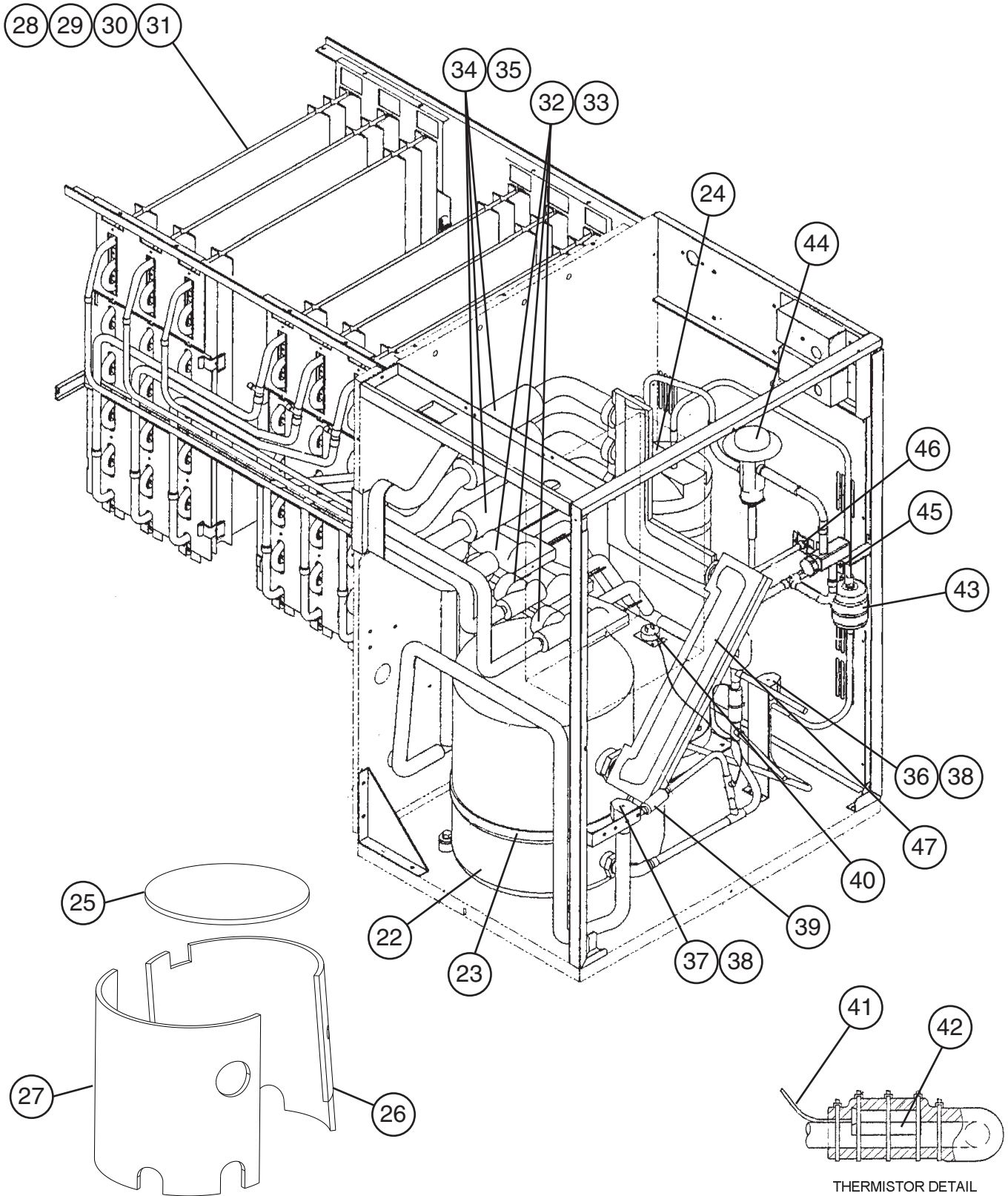

Title: A. Main Assembly & Refrigeration Circuit Model: KM-2400SRF3, KM-2400SRH3

Index No.	Description	Material or Model Number	Part Number	Required Number							
				J-0 to K-0	L-0 to M-1	M-2 to Q-0	R-0 to S-0	S-1 to U-0			
Main Assembly											
1	Front Panel	KM-2400SRF3	215382-01	1	-						
		KM-2400SRH3	3A1838G02		1	1	1	1			
2	Gasket	L=1219 mm	4A0808L02		1	1	1	1			
3	Top Panel		2A2096-01	1	1	1	-				
			2A2255-01				1	1			
4	Right Side Panel		215381G02	1	1	1	1	1			
5	Front Insulation		326041G01		1	1	1	1			
5a	Thumbscrew	KM-2400SRF3	415949G01	1	-						
		KM-2400SRH3	415949G12		1	1	1	1			
6	Top Insulation		324216G01	1	1	1	1	1			
7	Spacer		324321-01	1	1	1	1	1			
8	Control Box Cover		3A0174-01	1	1	-					
			3A2386-01			1	1	1			
9	Junction Box Cover		433410-01	1	1	1	1	1			
10	Bin Control Bulb Holder		3A3903-01	1	1	1	1	1			
11	Spacer		443545-01	1	1	2	-				
12	Bin Control Bulb Holder C		325845G01	1	1	1	1	1			
13	Bin Control Bulb Holder D		216340G01	1	1	1	1	1			
14	Spacer		439727-01	1	1	1	1	1			
15	Bin Control Bulb Holder E		439725-01	1	1	1	1	1			
16	Bin Control Bulb Holder F		328743-01	1	1						
16a	Thumbscrew		415949G01	1	1	1	-				
			415949G12				2	3			
17	Bin Control Bulb Holder G		439726-01	1	1	1	1	1			
18	Bin Control Extension Bracket		3A0408-01	1	1	1	1	1			
19	Silicone Hose	L=285 mm	773013812				1	1			
20	Main Transformer		2U0130-01	1	1	1	1	1			
21	Slide Switch		439305-01	1	1	-					
			4A1477-01			1	1	1			
Refrigeration Circuit											
22	Compressor		4A4782-01	1	1	1	1	1			
23	Crankcase Heater		4A2090-01	1	1	1	1	1			
24	Receiver Tank		440366-01	1	1	1	1	1			
25	Top Compressor Insulation		4A2078-01	1	1	1	1	1			
26	Right Compressor Insulation		4A2079-01	1	1	1	1	1			
27	Left Compressor Insulation		4A2080-01	1	1	1	1	1			
28	Evaporator	S-0641	103317G02	6	6	6	6	6			
29	Evaporator Plate A		325859-01	2	2	2	2	2			
30	Evaporator Plate B		325860-01	2	2	2	2	2			
31	Separator Hook		324152-01	8	8	8	8	8			
32	Thermostatic Expansion Valve		4A2053-01	3	3	3	3	3			
33	Thermostatic Expansion Valve Cover		4A1168-01	3	3	3	3	3			
34	Thermostatic Expansion Valve Bulb Holder		3A0112-01	3	3	3	3	3			
35	Clamp		443461-01	3	3	3	3	3			

Title: A. Main Assembly & Refrigeration Circuit Model: KM-2400SRF3, KM-2400SRH3

Index No.	Description	Material or Model Number	Part Number	Required Number										
				J-0 to K-0	L-0 to M-1	M-2 to Q-0	R-0 to S-0	S-1 to U-0						
36	Liquid Line Valve Body		4A3276-01	1	1	1	1	1						
37	Hot Gas Valve Body		4A3978-01	1	1	1	1	1						
38	Valve Coil		4A3277-01	2	2	2	2	2						
39	Strainer		441569-02	1	1	1	1	1						
40	High-Pressure Switch		433441-07	1	1	1	1	1						
41	Thermistor		429006-03	1	1	1	1	1						
42	Thermistor Holder		433563-01	1	1	1	1	1						
43	Drier		4A2663-01	1	1	1	1	1						
44	Headmaster (Condenser Pressure Regulator (C.P.R.))		4A2063-01	1	1	1	1	1						
45	Liquid Line Coupling		434136G03	1	1	1	1	1						
46	Suction Line Coupling		433751G01	1	1	1	1	1						
47	Heat Exchanger		2A1710G01	1	1	1	1	1						

B. Water Circuit
KM-2400SRF3, KM-2400SRH3
 J-0 to U-0

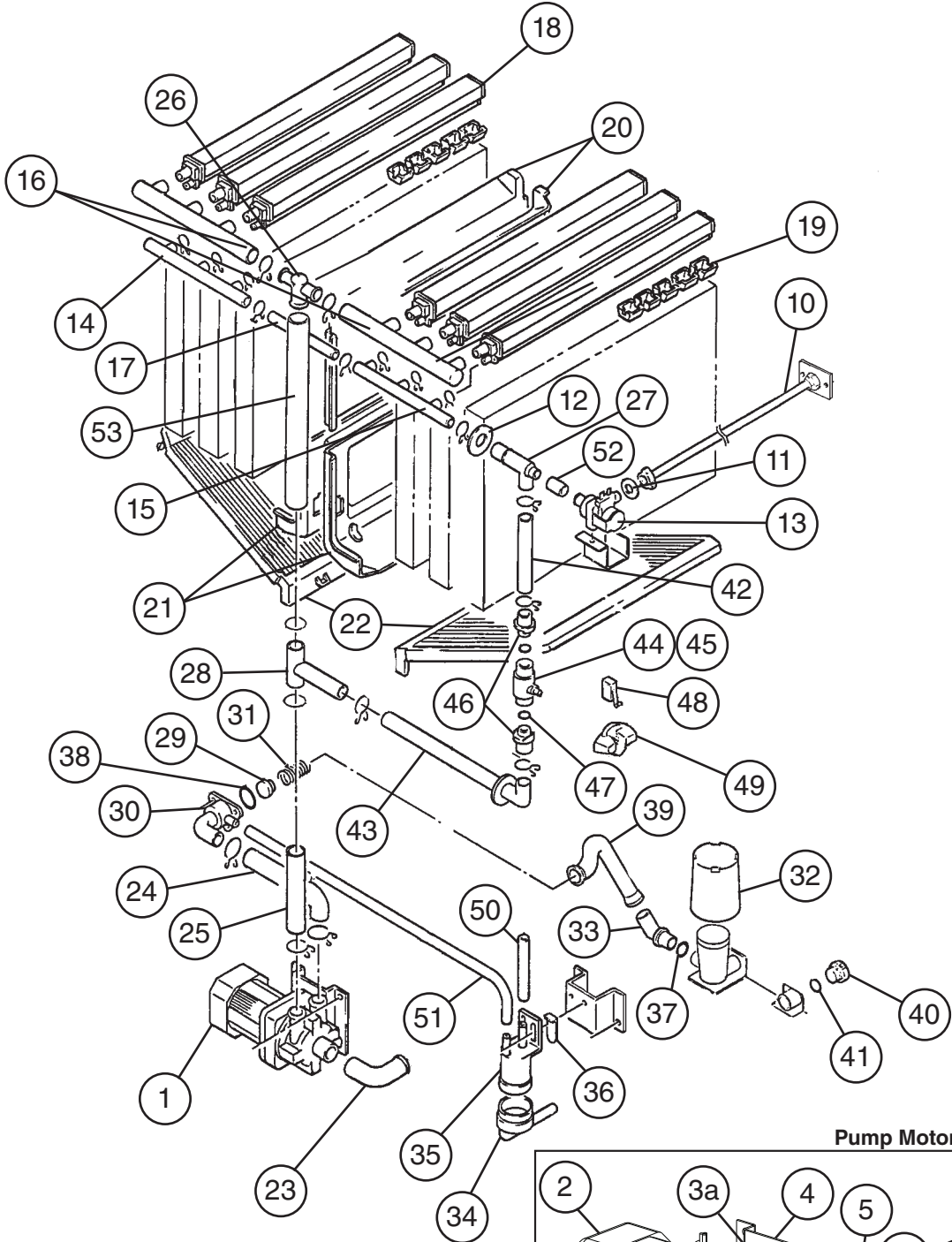

Pump Motor Assembly

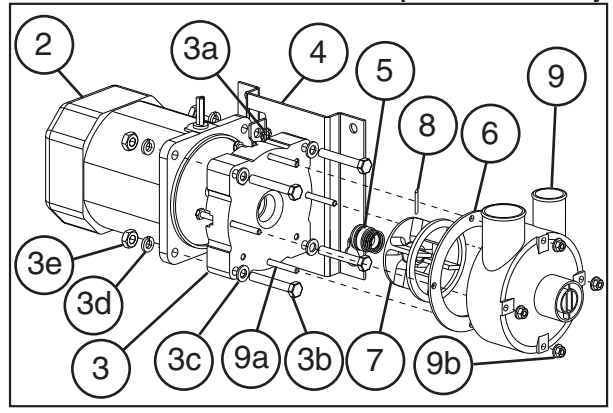

Title: B. Water Circuit Model: KM-2400SRF3, KM-2400SRH3

Index No.	Description	Material or Model Number	Part Number	Required Number																
				J-0 to U-0																
1	Pump Motor Assembly (includes items 2 through 9b)	S-0730	215691A01	1																
2	Pump Motor		2U0106-01	1																
3	Pump Flange		215662-01	1																
3a	Tooth Washer		7R22-0600	2																
3b	Hex Head Bolt	6x40	7B02-0640	4																
3c	Flat Washer		7W22-0600	4																
3d	Split Lock Washer		7L22-0600	4																
3e	Hex Nut		7N12-0600	4																
4	Pump Motor Bracket		323904-01	1																
5	Mechanical Seal		4A3820-01	1																
6	Packing		428547-01	1																
7	Impeller		436584-01	1																
8	Pin		4A0648-01	1																
9	Pump Housing		213687-01	1																
9a	Hex Head Bolt	4x55	7B02-0455	4																
9b	Hex Flange Nut		7J02-0400	4																
10	Water Supply Pipe		HS-2041	1																
11	Rubber Gasket		413854-03	1																
12	Flange		439267-02	1																
13	Inlet Water Valve		3U0136-01	1																
14	Distributor Hose A		325738-01	1																
15	Distributor Hose B		325738-02	1																
16	Distributor Hose C		325739-01	2																
17	Joint Pipe		439297-01	1																
18	Spray Tube		437049G01	6																
19	Spray Guide		208586-01	18																
20	Separator A		215046-01	2																
21	Separator B		2A0100-01	2																
22	Cube Guide		214243-01	2																
23	Inlet Hose A		435091-01	1																
24	Discharge Hose B		325867-01	1																
25	Discharge Vinyl Hose	L=230 mm	7716-2732	1																
26	Distributor A (Tee)		439266-01	1																
27	Distributor B (Tee)		439239-01	1																
28	Distributor C (Tee)		439238-01	1																
29	Drain Valve Seat		433705-01	1																
30	Drain Valve Housing		323613-01	1																
31	Spring		322110-01	1																
32	Overflow Cap		325866-01	1																
33	Overflow Joint		323923-02	1																
34	Float Switch Connector		426799-04	1																
35	Float Switch		4A2772-01	1																
36	Float Switch Stop		4A0137-01	1																
37	O-Ring		7611-P018	1																
38	O-Ring		7611-G035	1																

Title: B. Water Circuit Model: KM-2400SRF3, KM-2400SRH3												
Index No.	Description	Material or Model Number	Part Number	J-0 to U-0	Required Number							
39	Drain Hose		325869-01	1								
40	Drain Plug		309246-01	1								
41	O-Ring		7611-P015	1								
42	Joint Hose		439309-01	1								
43	Bypass Hose		439237-02	1								
44	Control Valve Ball Valve Assembly (includes items 45 through 47)	S-0761	442137A01	1								
45	Control Valve Ball Valve		439293-01	1								
46	Control Valve Male Adaptor		325826-01	2								
47	Control Valve O-Ring		7611-P018	2								
48	Control Valve Microswitch		4A2546-01	1								
49	Control Valve Handle		215383-01	1								
50	Silicone Hose	L=190 mm	773013812	1								
51	Silicone Hose	L=430 mm	773013896	1								
52	Vinyl Hose	L=40 mm	7716-1216	1								
53	Vinyl Hose	L=550 mm	7716-2732	1								
Hose Clamps												
	Hose Clamp (25 mm)		427443-03	9								
	Hose Clamp (13.5 mm)		427443-07	6								
	Hose Clamp (32 mm)		427443-09	7								

C. Control Box Assembly
KM-2400SRF3, KM-2400SRH3
 J-0 to U-0

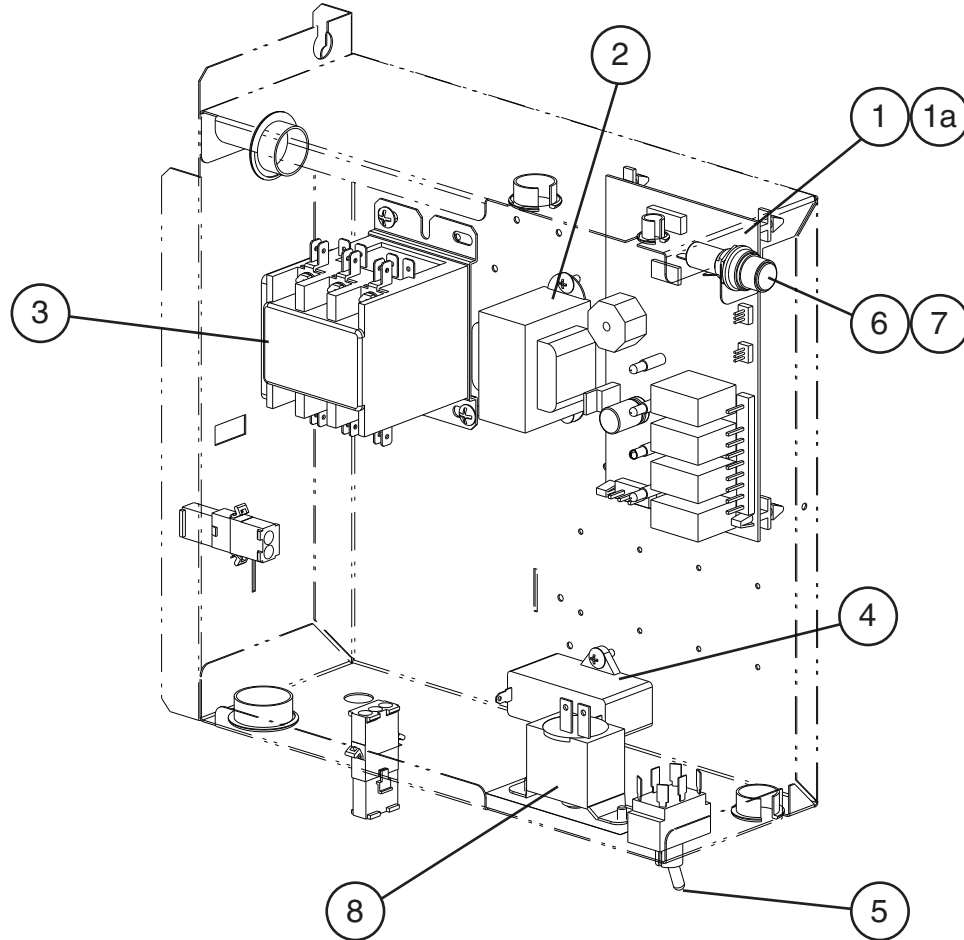

Title: C. Control Box Assembly		Model: KM-2400SRF3, KM-2400SRH3		Required Number									
Index No.	Description	Material or Model Number	Part Number	J-0 to K-0	L-0 to M-1	M-2 to Q-1	R-0 to U-0						
1	"E" Control Board		2A1410-02	1	1	1	1						
1a	Control Board Support		4A0336-03	4	4	4	4						
2	Control Transformer		3A0172-01	1	1	1	1						
3	Magnetic Contactor		4A0794-01	1	1	1	1						
4	Pump Motor Capacitor	10MFD, 250VAC	443192-01	1	-								
		15MFD, 240VAC	439705-01		1	1	1						
5	Power Switch		443119-01	1	1	1	1						
6	Fuse	AGC-10A, 250VAC	4A0893-07			1	1						
7	Fuse Holder		4A0892-01			1	-						
			4A3449-01				1						
8	Bin Control Thermostat		4A0824-02	1	1	-							
			4A2879-02			1	1						

D. Accessories & Labels
KM-2400SRF3, KM-2400SRH3
 J-0 to U-0

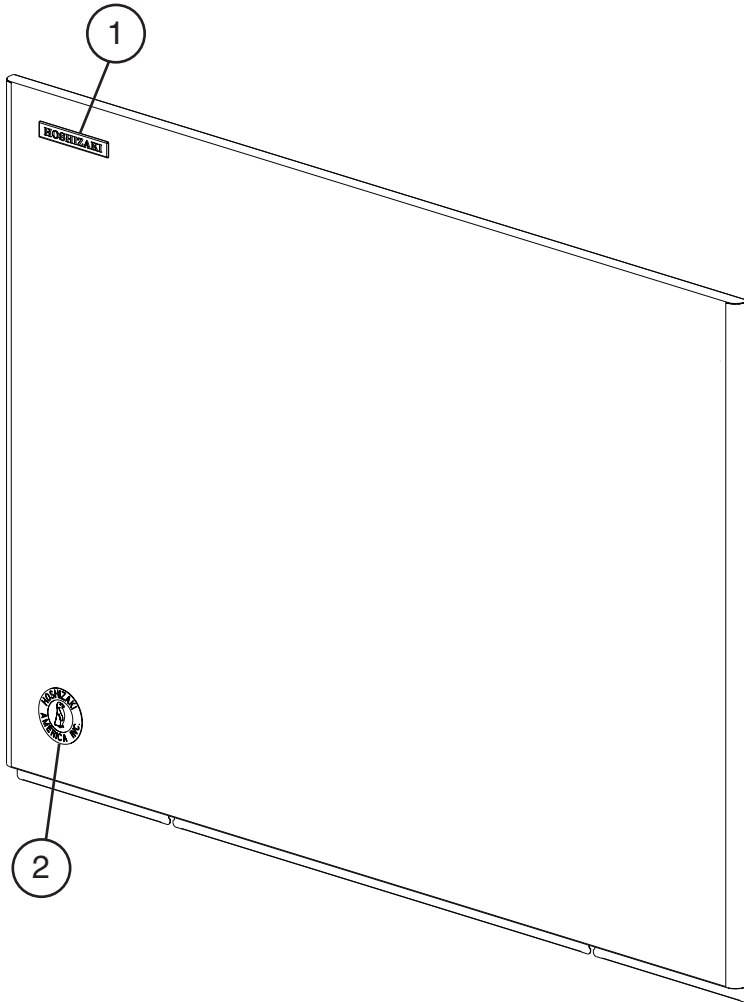

Title: D. Accessories & Labels Model: KM-2400SRH3												
Index No.	Description	Material or Model Number	Part Number	Required Number								
				J-0 to U-0								
1	Hoshizaki Emblem Label		4A0560-01	1								
2	Penguin Label		4A0526-01	1								
3	Universal Brace		4A0363-01	2								
4	Hex Head Bolt	5x12, SS	7B02-0512	4								
5	T2 Screw	4x16, SS	7P32-0416	2								