

NO. 71089

ISSUED: DEC. 22, 1992

REVISED: DEC. 1, 2004



**HOSHIZAKI
STACKABLE CRESCENT CUBER
MODEL**

KM-1600SWE

KM-1600SWE3

KM-1600SRE

KM-1600SRE3

(FINAL) PARTS LIST

KM-1600SWE

D-0 May, 1994
E-0 Jan., 1995
E-1 June, 1995
F-0 Jan., 1996
F-1 Sept., 1996
G-0 June, 1997
H-0 March, 1998

KM-1600SWE3

D-0 April, 1994
E-0 March, 1995
F-1 Sept., 1996
G-1 June, 1997
H-0 Dec., 1997

KM-1600SRE

D-0 April, 1994
E-0 Jan., 1995
E-1 May, 1995
F-0 Jan., 1996
F-1 July, 1996
G-0 Jan., 1997
G-1 June, 1997
G-2 Nov., 1997
H-0 Jan., 1998
H-1 June, 1998

KM-1600SRE3

D-0 April, 1994
E-0 Dec., 1994
E-1 May, 1995
F-0 Dec., 1995
F-1 July., 1996
G-0 Jan., 1997
G-1 June, 1997
H-0 Dec, 1997

MATERIAL ABBREVIATIONS

ALUMINUM

AL = Aluminum

COPPER

CU = Copper

PLASTIC

ABS = Acrylonitrile -butadiene - styrene
 AC = Polyacetal
 EVA = Ethylene vinyl acetate
 PA = Polyamide = Nylon
 PC = Polycarbonate
 PE = Polyethylene
 PES = Polyester
 PETP = Polyethylene terephthalate = Tetlon
 PP = Polypropylene
 PS = Polystyrene
 PTFE = Polytetrafluoroethylene = Teflon
 PUR = Polyurethane
 PVC = Polyvinyl chloride

RUBBER

VN = Vinyl Nitrile
 EPDM = EP rubber
 NBR = Nitrile butadiene rubber
 NR = Natural rubber
 NP = Neoprene
 SI.R = Silicone rubber
 SY.R = Synthetic rubber
 EPH = Epichlorohydrin

STEEL

GS = Galvanized steel
 SS = Stainless steel
 PS = Plated steel
 PAS = Primed steel

AUXILIARY CODE

Ex.1

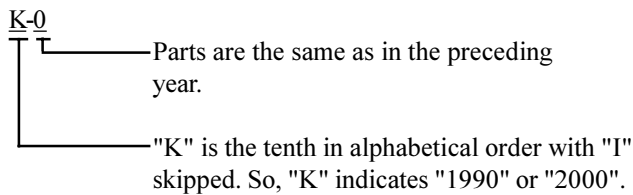

(Note) - = Part deleted.

x = Part deleted and replaced by "o" part.

o = New part for "x" in the same auxiliary code.

Ex.2

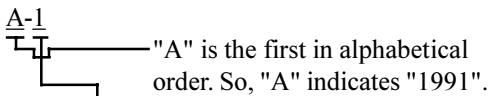

Ex.3

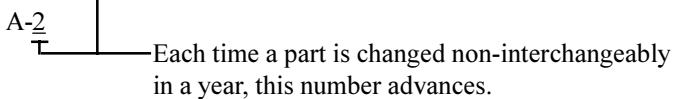

FASTENER ABBREVIATION LIST

ST	Phillips Truss Machine Screw
SP	Phillips Pan Head Machine Screw
SF	Phillips Flat Head Machine Screw
SS	Phillips Pan Head Machine Screw with Split Lock Washer
SW	Phillips Pan Head Machine Screw with Split Lock Washer and Flat Washer
T1	Phillips Truss Head Tapping Screw (Correspond to Type A)
T2	Phillips Truss Head Tapping Screw (Correspond to Type B)
T3	Phillips Truss Head Tapping Screw (Correspond to Type C)
FT	Phillips Truss Head Tapping Screw (Special)
BH	Hexagon Head Bolt
BC	Socket Head Cap Screw
BS	Hexagon Bolt with Split Washer
BW	Hexagon Bolt with Split Washer and Flat Washer
BF	Hexagon Flange Bolt
BR	Cross-Recessed Hexagon Head Bolt
BRW	Cross-Recessed Hexagon Head Bolt with Split Lock Washer and Flat Washer
WL	Split Lock Washer
WT	External Tooth Washer
WF	Flat Washer
WS	Spring Washer
NH	Hexagon Nut
NF	Hexagon Flange Nut
NC	Hexagon Cap Nut
NS	Square Nut
NW	Wing Nut

Ex. ST0308S (Phillips Truss Head Machine Screw
3x8, made of stainless steel)

Material	None:	Plated Steel
Length (mm)	S:	Stainless Steel
Nominal Diameter (mm)	B:	Brass
Form of Head	P:	Plastic
Description		

(Note) Second character is numerical except toe list.

Ex. S1, S2, B3 etc.

And abbreviations and names are shown under the illustration.

HA

KM-1600SWE

A. ICE CUBER ASSEMBLY

D-0, E-0, E-1, F-0,
F-1, G-0, H-0

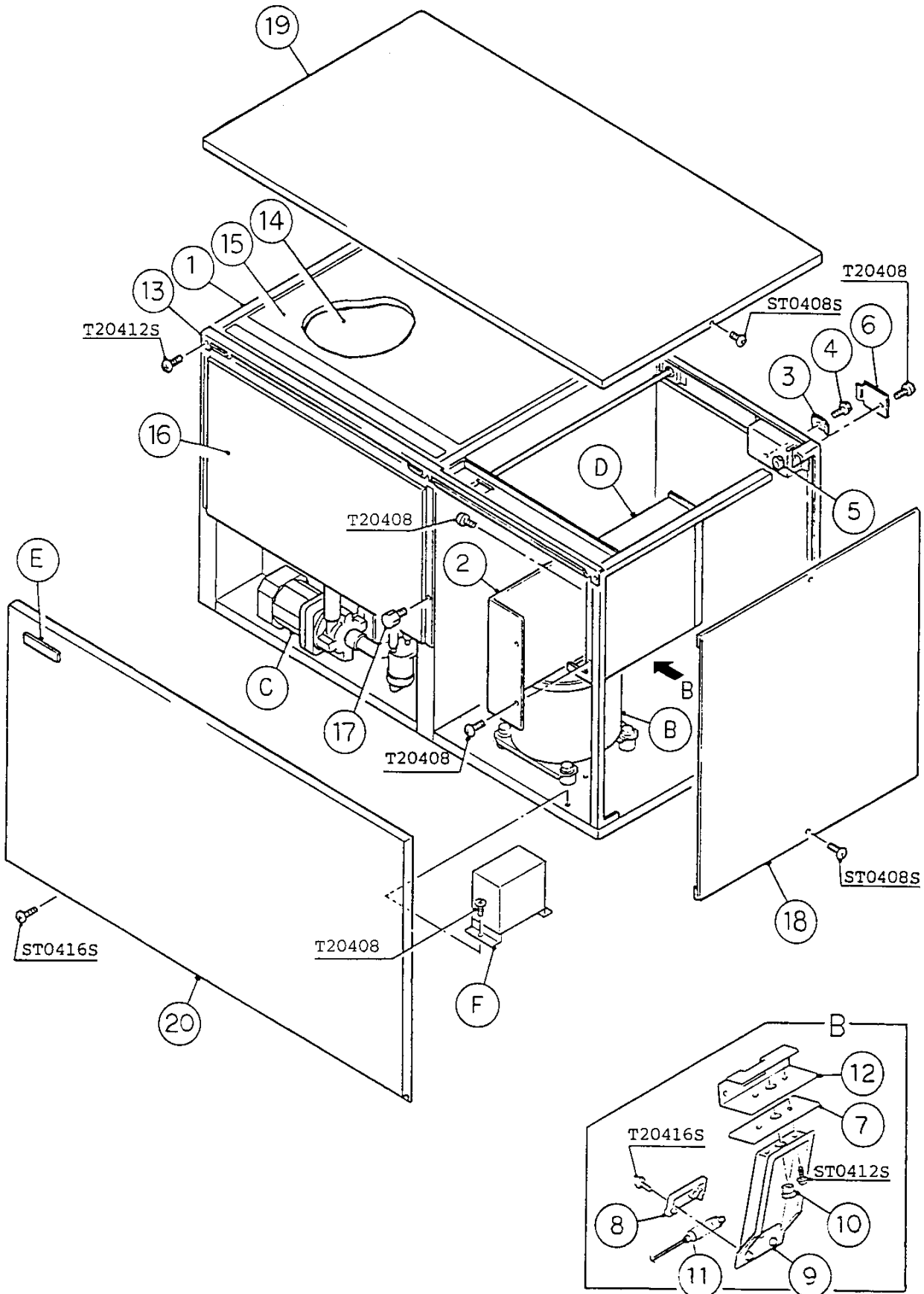

MODEL: KM-1600SWE TITLE: A. ICE CUBER ASSEMBLY													
INDEX NO.	DESCRIPTION	MATERIAL OR MODEL NUMBER	PART NUMBER	REQUIRED NUMBER									
				D-0	E-0	E-1	F-0	F-1	G-0	H-0			
B	REFRIGERATION CIRCUIT	-	106530A01	1	1	-							
		-	106530A03			1	1	1	1	1			
C	WATER CIRCUIT	-	105109A02	1	1	-							
		-	105109A03			1	1	1	1	-			
		-	105109A04								1		
D	CONTROL BOX ASSEMBLY	-	219335A04	1	1	1	1	1	1	1			
E	LABEL LOCATION	-	219473A01	1	1	1	1	1	1	1			
F	CAPACITOR BOX ASSEMBLY	-	326126A02	1	1	1	1	1	1	1			
1	EVAPORATOR CASE	-	105860G04	1	1	-							
		-	105860G12			1	1	1	1	-			
		-	105860G23								1		
2	CONTROL BOX COVER	GS	3A0174-01	1	1	1	1	1	1	1			
3	SQUARE WASHER	BRASS	433537-02	1	1	1	1	1	1	1			
4	SCREW - GROUNDING	BRASS	433304-02	1	1	1	1	1	1	1			
5	BUSHING	SR-34-2	420472-05	1	1	1	1	1	1	1			
6	JUNCTION BOX COVER	GS	433410-01	1	1	1	1	1	1	1			
7	SPACER	ABS	440907-01	1	1	1	1	1	1	-			
		-	439727-01								1		
8	BULB HOLDER	PE	328919-01	1	1	1	1	1	1	1			
9	BULB HOLDER (C)	ABS	216340G01	1	1	1	1	1	1	1			
10	BUSHING	EPDM	425307-01	1	1	1	1	1	1	1			
11	SPACER	PE	443545-01	1	1	1	1	1	1	1			
12	BULB HOLDER (D)	GS	328742-01	1	1	1	1	1	1	1			
13	FRONT PANEL - BRACKET	SS	323903-01	1	1	1	1	1	1	1			
14	SPACER	ABS	324321-01	1	1	1	1	1	1	1			
15	TOP INSULATION	ABS, PE	324216G01	1	1	1	1	1	1	1			
16	FRONT INSULATION	ABS, PE	324215G01	1	1	1	1	1	1	1			
17	THUMBSCREW	ABS, SS	415949G01	1	1	1	1	1	1	1			
18	SIDE PANEL (R)	SS	213668G01	1	1	1	1	1	1	1			

HA

MODEL: KM-1600SWE TITLE: A. ICE CUBER ASSEMBLY													
INDEX NO.	DESCRIPTION	MATERIAL OR MODEL NUMBER	PART NUMBER	REQUIRED NUMBER									
				D-0	E-0	E-1	F-0	F-1	G-0	H-0			
19	TOP PANEL (A)	SS	213669-01	1	x1								
		SS	213669-02		o1	1	1	1	x1				
		SS	213669-01						o1	1			
20	FRONT PANEL	SS	325508G01	1	1	1	1	1	1	1			

HA

KM-1600SWE3

A. ICE CUBER ASSEMBLY

D-0, E-0, F-1, G-1, H-0

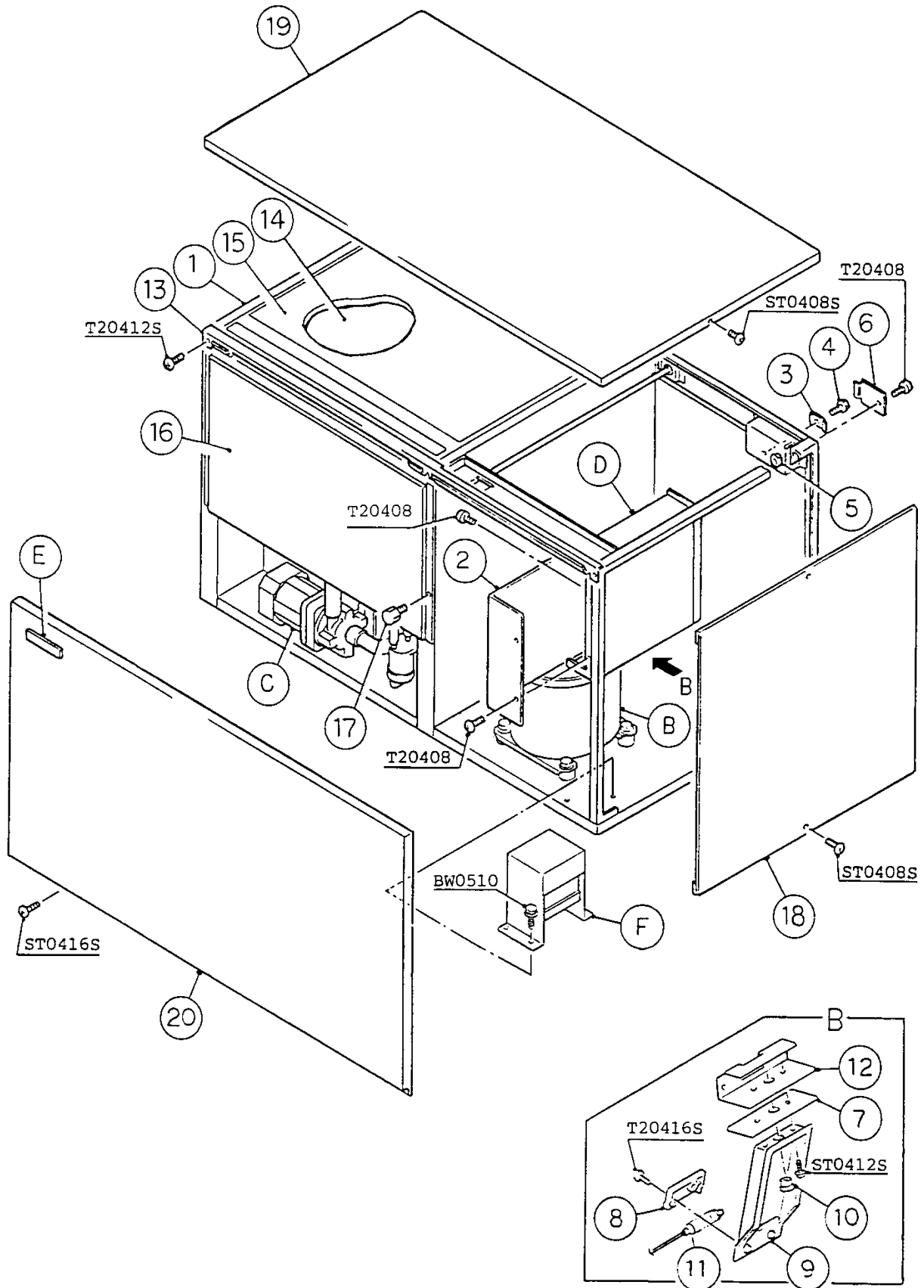

HA

MODEL: KM-1600SWE3 TITLE: A. ICE CUBER ASSEMBLY													
INDEX NO.	DESCRIPTION	MATERIAL OR MODEL NUMBER	PART NUMBER	REQUIRED NUMBER									
				D-0	E-0	F-1	G-1	H-0					
B	REFRIGERATION CIRCUIT	-	106530A02	1	1	-							
		-	106530A04			1	1	1					
C	WATER CIRCUIT	-	105109A02	1	1	-							
		-	105109A03			1	1	-					
		-	105109A04					1					
D	CONTROL BOX ASSEMBLY	-	219335A04	1	1	1	1	1					
E	LABEL LOCATION	-	219473A02	1	1	1	1	1					
F	TRANSFORMER BOX ASSEMBLY	-	333073A01	1	1	1	1	1					
1	EVAPORATOR CASE	-	105860G04	1	1	-							
		-	105860G12			1	1	-					
		-	105860G23					1					
2	CONTROL BOX COVER	GS	3A0174-01	1	1	1	1	1					
3	SQUARE WASHER	BRASS	433537-02	1	1	1	1	1					
4	SCREW - GROUNDING	BRASS	433304-02	1	1	1	1	1					
5	BUSHING	SR-34-2	420472-05	1	1	1	1	1					
6	JUNCTION BOX COVER	GS	433410-01	1	1	1	1	1					
7	SPACER	ABS	440907-01	1	1	1	1	x1					
		-	439727-01					o1					
8	BULB HOLDER	PE	328919-01	1	1	1	1	1					
9	BULB HOLDER (C)	ABS	216340G01	1	1	1	1	1					
10	BUSHING	EPDM	425307-01	1	1	1	1	1					
11	SPACER	PE	443545-01	1	1	1	1	1					
12	BULB HOLDER (D)	GS	328742-01	1	1	1	1	1					
13	FRONT PANEL - BRACKET	SS	323903-01	1	1	1	1	1					
14	SPACER	ABS	324321-01	1	1	1	1	1					
15	TOP INSULATION	ABS, PE	324216G01	1	1	1	1	1					
16	FRONT INSULATION	ABS, PE	324215G01	1	1	1	1	1					
17	THUMBSCREW	ABS, SS	415949G01	1	1	1	1	1					
18	SIDE PANEL (R)	SS	213668G01	1	1	1	1	1					

HA

MODEL: KM-1600SWE3 TITLE: A. ICE CUBER ASSEMBLY													
INDEX NO.	DESCRIPTION	MATERIAL OR MODEL NUMBER	PART NUMBER	REQUIRED NUMBER									
				D-0	E-0	F-1	G-1	H-0					
19	TOP PANEL (A)	SS	213669-01	1	x1								
		SS	213669-02		o1	1	1	x1					
		SS	213669-01					o1					
20	FRONT PANEL	SS	325508G01	1	1	1	1	1					

HA

KM-1600SRE

A. ICE CUBER ASSEMBLY

D-0, E-0, E-1, F-0, F-1,
G-0, G-1, G-2, H-0, H-1

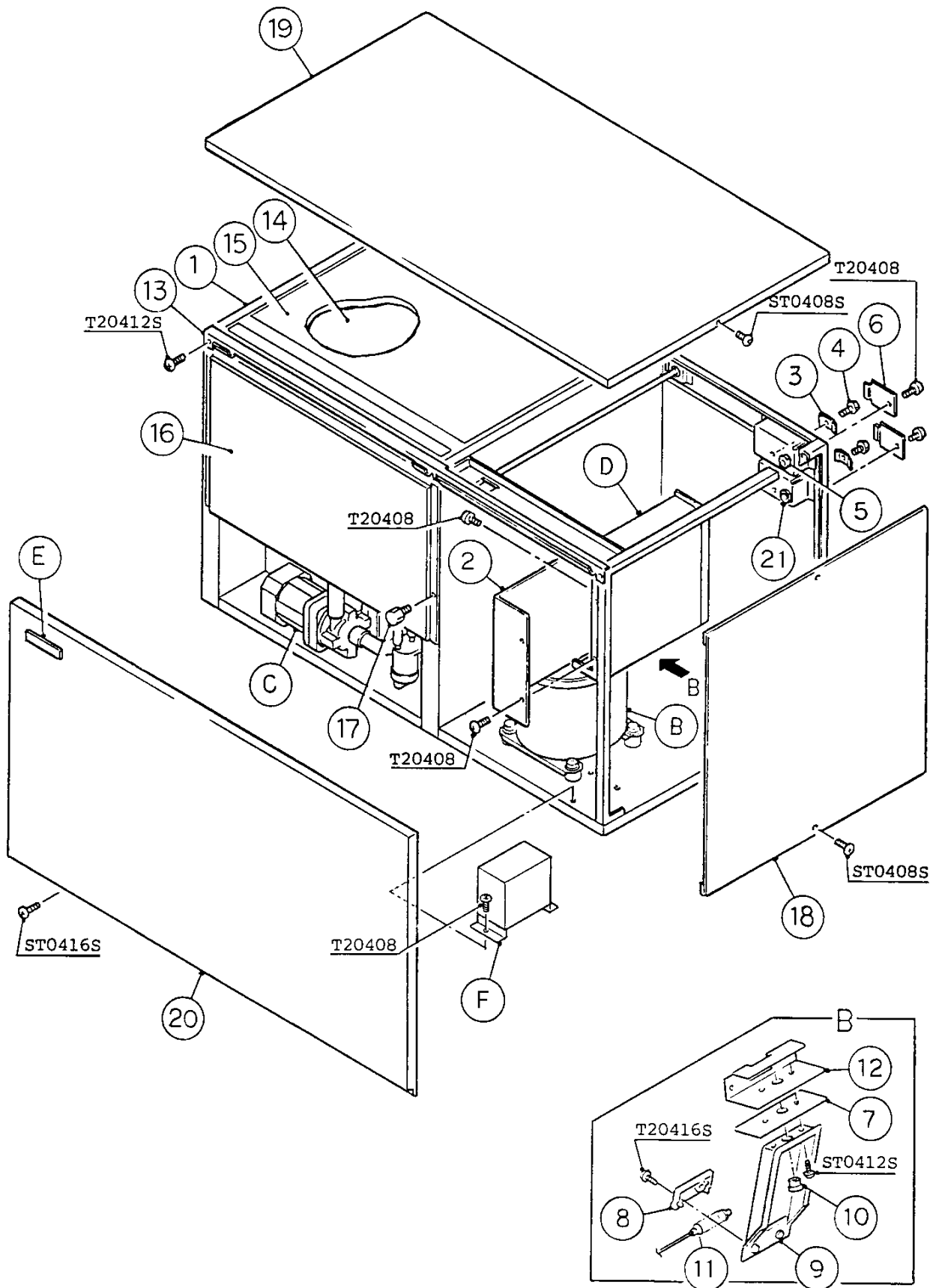

MODEL: KM-1600SRE TITLE: A. ICE CUBER ASSEMBLY													
INDEX NO.	DESCRIPTION	MATERIAL OR MODEL	PART NUMBER	REQUIRED NUMBER									
				D-0	E-0	E-1	F-0	F-1	G-0	G-1	G-2	H-0	H-1
B	REFRIGERATION CIRCUIT	-	106530A01	1	1	-							
		-	106530A03			1	1	1	1	1	1	1	1
C	WATER CIRCUIT	-	105109A02	1	1	-							
		-	105109A03			1	1	1	1	1	1	1	-
		-	105109A04										1
D	CONTROL BOX ASSEMBLY	-	219335A04	1	1	1	1	1	1	1	1	1	1
E	LABEL LOCATION	-	219332A01	1	1	1	1	1	1	1	1	1	1
F	CAPACITOR BOX ASSEMBLY	-	326126A02	1	1	1	1	1	1	1	1	1	1
1	EVAPORATOR CASE	-	105860G05	1	1	-							
		-	105860G13			1	1	1	1	1	1	-	
		-	105860G24									1	1
2	CONTROL BOX COVER	GS	3A0174-01	1	1	1	1	1	1	1	1	1	1
3	SQUARE WASHER	BRASS	433537-02	2	2	2	2	2	2	2	2	2	2
4	SCREW - GROUNDING	BRASS	433304-02	2	2	2	2	2	2	2	2	2	2
5	BUSHING	SR-30-1	420472-03	1	1	1	1	1	1	1	1	1	1
6	JUNCTION BOX COVER	GS	433410-01	2	2	2	2	2	2	2	2	2	2
7	SPACER	ABS	440907-01	1	1	1	1	1	1	1	1	x1	
		-	439727-01									o1	1
8	BULB HOLDER	PE	328919-01	1	1	1	1	1	1	1	1	1	1
9	BULB HOLDER (C)	ABS	216340G01	1	1	1	1	1	1	1	1	1	1
10	BUSHING	EPDM	425307-01	1	1	1	1	1	1	1	1	1	1
11	SPACER	PE	443545-01	1	1	1	1	1	1	1	1	1	1
12	BULB HOLDER (D)	GS	328742-01	1	1	1	1	1	1	1	1	1	1
13	FRONT PANEL - BRACKET	SS	323903-01	1	1	1	1	1	1	1	1	1	1
14	SPACER	ABS	324321-01	1	1	1	1	1	1	1	1	1	1
15	TOP INSULATION	ABS, PE	324216G01	1	1	1	1	1	1	1	1	1	1
16	FRONT INSULATION	ABS, PE	324215G01	1	1	1	1	1	1	1	1	1	1
17	THUMBSCREW	ABS, SS	415949G01	1	1	1	1	1	1	1	1	1	1

MODEL: KM-1600SRE TITLE: A. ICE CUBER ASSEMBLY													
INDEX NO.	DESCRIPTION	MATERIAL OR MODEL	PART NUMBER	REQUIRED NUMBER									
				D-0	E-0	E-1	F-0	F-1	G-0	G-1	G-2	H-0	H-1
18	SIDE PANEL (R)	SS	213668G01	1	1	1	1	1	1	1	1	1	1
19	TOP PANEL (A)	SS	213669-01	1	x1								
		SS	213669-02		o1	1	1	1	1	1	1	1	x1
		SS	213669-01										o1
20	FRONT PANEL	SS	325508G01	1	1	1	1	1	1	1	1	1	1
21	BUSHING	SR-34-2	420472-05	1	1	1	1	1	1	1	1	1	1

HA

KM-1600SRE3

A. ICE CUBER ASSEMBLY

D-0, E-0, E-1, F-0,
F-1, G-0, G-1, H-0

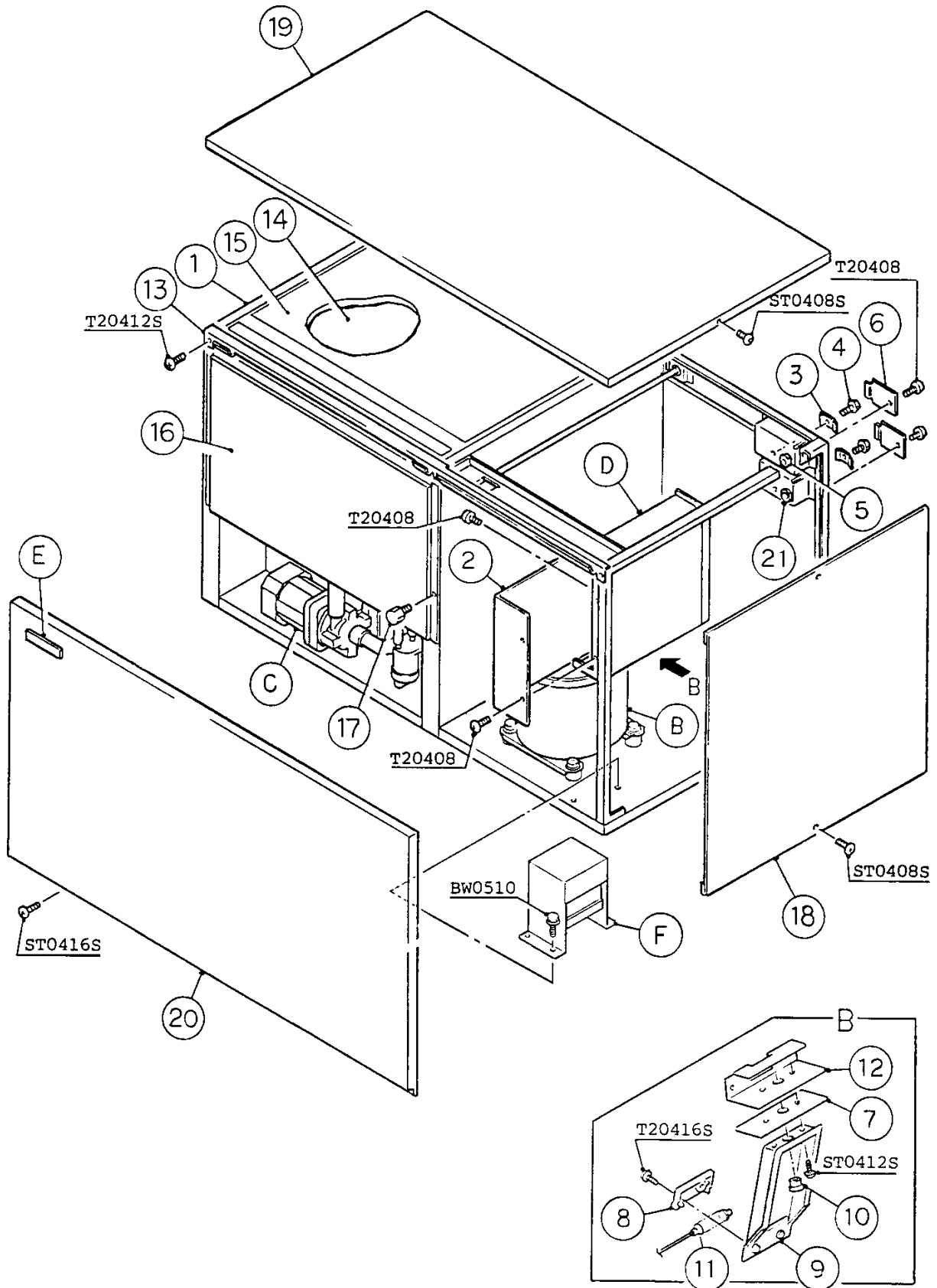

MODEL: KM-1600SRE3 TITLE: A. ICE CUBER ASSEMBLY													
INDEX NO.	DESCRIPTION	MATERIAL OR MODEL	PART NUMBER	REQUIRED NUMBER									
				D-0	E-0	E-1	F-0	F-1	G-0	G-1	H-0		
B	REFRIGERATION CIRCUIT	-	106529A02	1	1	-							
		-	106529A04			1	1	1	1	1	1		
C	WATER CIRCUIT	-	105109A02	1	1	-							
		-	105109A03			1	1	1	1	1	x1		
		-	105109A04								o1		
D	CONTROL BOX ASSEMBLY	-	219335A04	1	1	1	1	1	1	1	1		
E	LABEL LOCATION	-	219332A02	1	1	1	1	1	1	1	1		
F	TRANSFORMER BOX ASSEMBLY	-	333073A01	1	1	1	1	1	1	1	1		
1	EVAPORATOR CASE	-	105860G05	1	1	-							
		-	105860G13			1	1	1	1	1	-		
		-	105860G24								1		
2	CONTROL BOX COVER	GS	3A0174-01	1	1	1	1	1	1	1	1		
3	SQUARE WASHER	BRASS	433537-02	2	2	2	2	2	2	2	2		
4	SCREW - GROUNDING	BRASS	433304-02	2	2	2	2	2	2	2	2		
5	BUSHING	SR-30-1	420472-03	1	1	1	1	1	1	1	1		
6	JUNCTION BOX COVER	GS	433410-01	2	2	2	2	2	2	2	2		
7	SPACER	ABS	440907-01	1	1	1	1	1	1	1	x1		
		-	439727-01								o1		
8	BULB HOLDER	PE	328919-01	1	1	1	1	1	1	1	1		
9	BULB HOLDER (C)	ABS	216340G01	1	1	1	1	1	1	1	1		
10	BUSHING	EPDM	425307-01	1	1	1	1	1	1	1	1		
11	SPACER	PE	443545-01	1	1	1	1	1	1	1	1		
12	BULB HOLDER (D)	GS	328742-01	1	1	1	1	1	1	1	1		
13	FRONT PANEL - BRACKET	SS	323903-01	1	1	1	1	1	1	1	1		
14	SPACER	ABS	324321-01	1	1	1	1	1	1	1	1		
15	TOP INSULATION	ABS, PE	324216G01	1	1	1	1	1	1	1	1		
16	FRONT INSULATION	ABS, PE	324215G01	1	1	1	1	1	1	1	1		
17	THUMBSCREW	ABS, SS	415949G01	1	1	1	1	1	1	1	1		
18	SIDE PANEL (R)	SS	213668G01	1	1	1	1	1	1	1	1		

HA

MODEL: KM-1600SRE3 TITLE: A. ICE CUBER ASSEMBLY													
INDEX NO.	DESCRIPTION	MATERIAL OR MODEL	PART NUMBER	REQUIRED NUMBER									
				D-0	E-0	E-1	F-0	F-1	G-0	G-1	H-0		
19	TOP PANEL (A)	SS	213669-01	1	x1								
		SS	213669-02		o1	1	1	1	1	1	1	x1	
		SS	213669-01									o1	
20	FRONT PANEL	SS	325508G01	1	1	1	1	1	1	1	1	1	
21	BUSHING	SR-34-2	420472-05	1	1	1	1	1	1	1	1	1	

HA

KM-1600SWE, SWE3

B. REFRIGERATION CIRCUIT (1/2)

D-0, E-0, E-1, F-0,
F-1, G-0, H-0

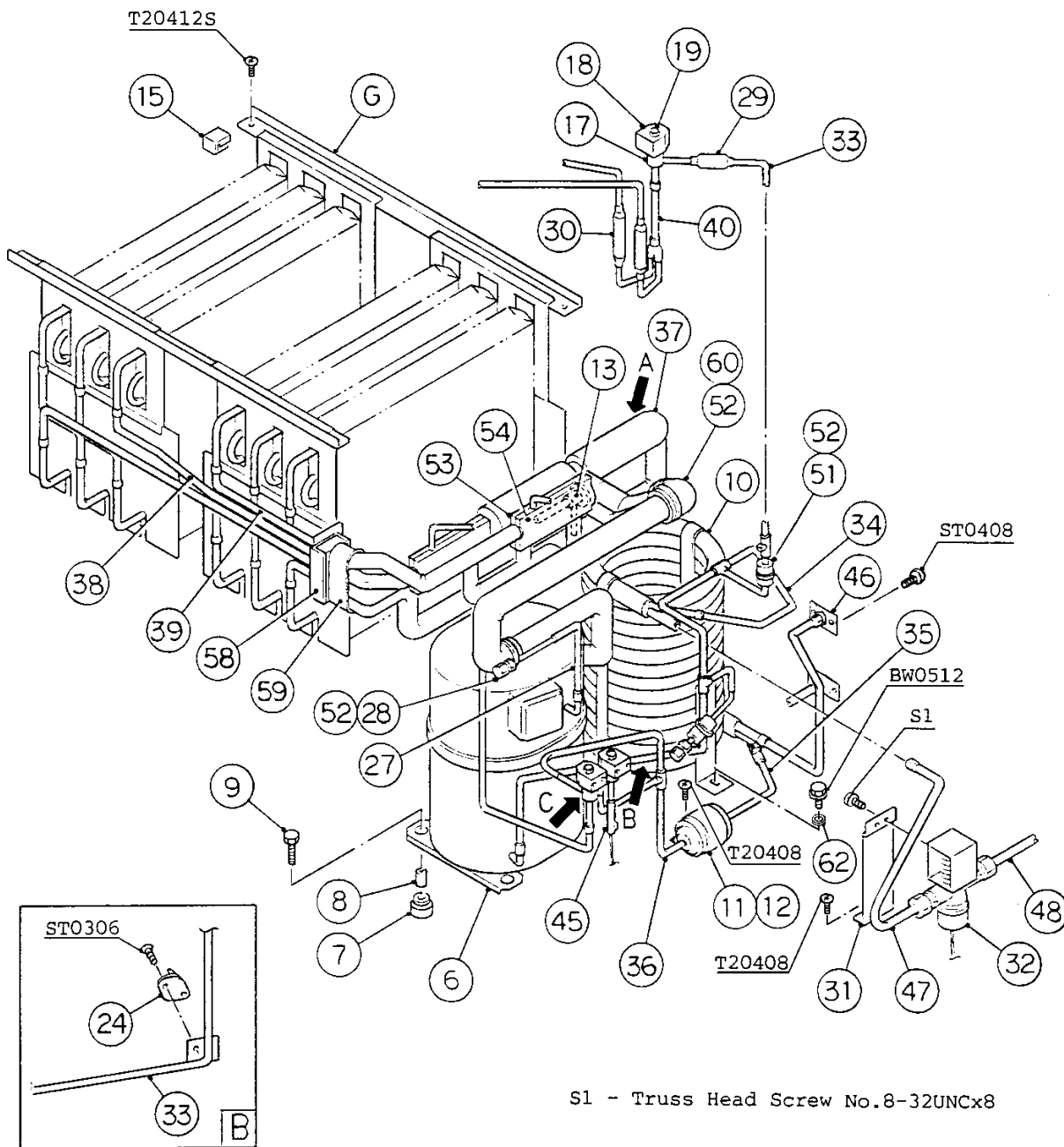
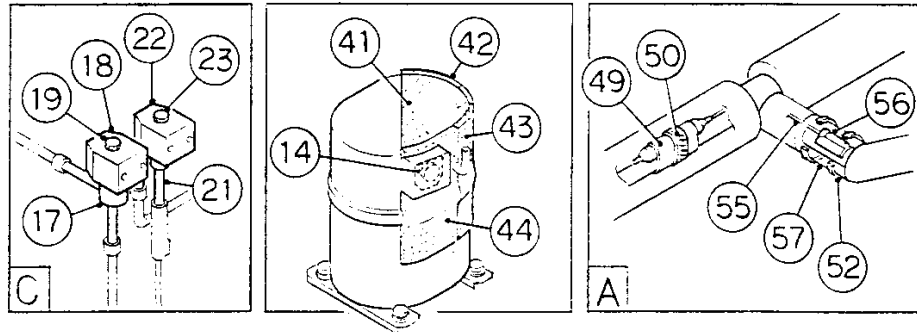

S1 - Truss Head Screw No.8-32UNCx8

HA

KM-1600SWE, SWE3

B. REFRIGERATION CIRCUIT (2/2)

D-0, E-0, E-1, F-0,
F-1, G-0, H-0

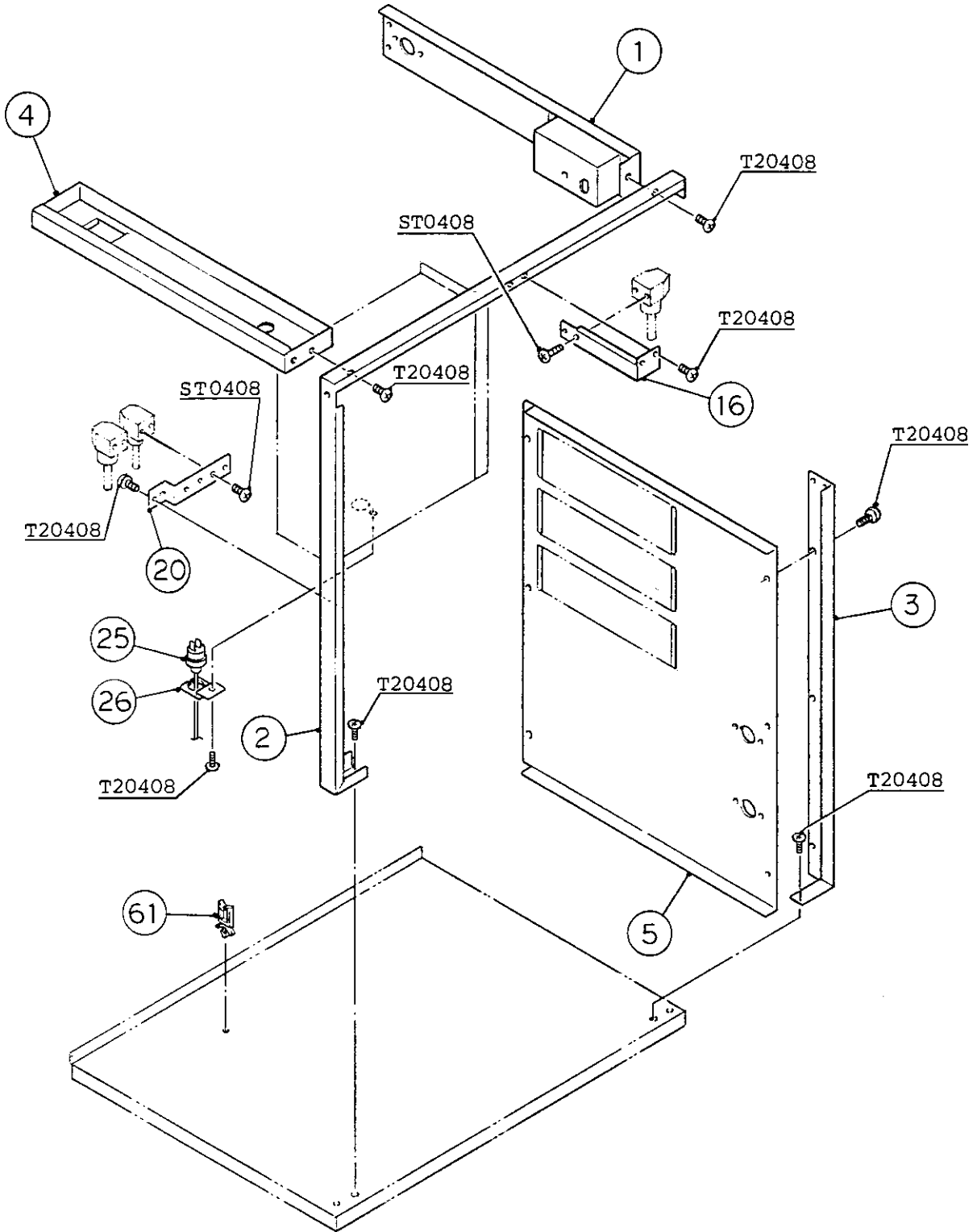

MODEL: KM-1600SWE TITLE: B. REFRIGERATION CIRCUIT														
INDEX NO.	DESCRIPTION	MATERIAL OR MODEL	PART NUMBER	REQUIRED NUMBER										
				D-0	E-0	E-1	F-0	F-1	G-0	H-0				
G	EVAPORATOR	-	104696A01	1	1	1	1	1	1	1	1			
1	REAR FRAME	GS	439285G03	1	1	-								
		GS	439285G04			1	1	1	1	1	1			
2	SIDE FRAME (A)	GS	219472G01	1	1	1	1	1	1	1	1			
3	SIDE FRAME (B)	GS	323901G01	1	1	1	1	1	1	1	1			
4	FRONT FRAME	GS	325857-01	1	1	1	1	1	1	1	1			
5	REAR PANEL (A)	GS	219569-01	1	1	-								
		GS	219569-02			1	1	1	1	1	1			
6	COMPRESSOR	H23A463ABCA	438202-02	1	1	1	1	1	1	1	1			
7	GROMMET	027-0167-00	434922-01	4	4	4	4	4	4	4	4			
8	SPACER	028-0188-02	434921-01	4	4	4	4	4	4	4	4			
9	BOLT	8 x 45	437889-01	4	4	4	4	4	4	4	4			
10	CONDENSER - WATER-COOLED	-	219382-01	1	1	1	1	1	1	1	1			
11	DRIER	C-530-S	445011-01	1	1	1	1	1	1	1	1			
12	DRIER BRACKET	GS	445251-01	1	1	1	1	1	1	1	1			
13	EXPANSION VALVE	HFE-15HHD-2	445542-01	2	2	2	2	2	2	2	2			
14	TERMINAL GASKET	-	334084-01	1	1	1	1	1	1	1	1			
15	FRAME SEAL	EPDM	323925-01	4	4	4	4	4	4	4	4			
16	HOT GAS VALVE BRACKET	GS	440507-01	1	1	1	1	1	1	1	1			
17	VALVE BODY	70	440352-01	2	2	2	2	2	2	2	2			
18	COIL - VALVE	ABS-25-1-HD-2	440353-01	2	2	2	2	2	2	2	2			
19	BOLT	4 x 6	440353F01	2	2	2	2	2	2	2	2			
20	LINE VALVE BRACKET	GS	438213-01	1	1	1	1	1	1	1	1			
21	VALVE BODY	24	440351-01	1	1	1	1	1	1	1	1			
22	COIL - VALVE	ADS-24HD-3	440354-01	1	1	1	1	1	1	1	1			
23	BOLT	4 x 6	440354F01	1	1	1	1	1	1	1	1			
24	THERMOSTAT	US-602SXTTBL	445595-01	1	1	1	1	1	1	1	1			
25	PRESSURE SWITCH	ACB-2UB02	433441-01	1	1	1	1	1	1	1	1			
26	PRESSURE SWITCH BRCKT.	GS	434938-01	1	1	1	1	1	1	1	1			
27	COPPER TUBE - ACCESS VALVE	COPPER	439761-02	1	1	1	1	1	1	1	1			

MODEL: KM-1600SWE TITLE: B. REFRIGERATION CIRCUIT														
INDEX NO.	DESCRIPTION	MATERIAL OR MODEL	PART NUMBER	REQUIRED NUMBER										
				D-0	E-0	E-1	F-0	F-1	G-0	H-0				
28	ACCESS VALVE	TCJ-2F15-HD	417366-01	2	2	2	2	2	2	2	2			
29	STRAINER	-	441569-02	1	1	1	1	1	1	1	1			
30	CHECK VALVE	YCV5-2	425342-01	2	2	2	2	2	2	2	2			
31	WATER REGULATOR BRCKT.	GS	445172-01	1	1	1	1	1	1	1	1			
32	WATER REG. ASSEMBLY	(S-0815)	446716G01	1	1	1	1	1	1	1	1			
33	COPPER TUBE (A) - HIGH SIDE	COPPER	219470G01	1	1	1	1	1	1	1	1			
34	COPPER TUBE (B) - HIGH SIDE	COPPER	331186-01	1	1	1	1	1	1	1	1			
35	COPPER TUBE (C) - HIGH SIDE	COPPER	446548G01	1	1	1	1	1	1	1	1			
36	COPPER TUBE (F) - HIGH SIDE	COPPER	219590G01	1	1	1	1	1	1	1	1			
37	HEAT EXCHANGER	COPPER	106498G01	1	1	1	1	1	1	1	1			
38	COPPER TUBE (R) - HIGH SIDE	COPPER	219591G01	1	1	1	1	1	1	1	1			
39	COPPER TUBE (L) - LOW SIDE	COPPER	219593G01	1	1	1	1	1	1	1	1			
40	COPPER TUBE - HOT GAS	COPPER	3A0212G01	1	1	1	1	1	1	1	1			
41	INSULATION - COMPRESSOR TOP	VNN 2C1 (SOFT)	447118-01	1	1	1	1	1	1	1	1			
42	INSULATION - COMPRESSOR RIGHT	VNN 2C1 (SOFT)	447119-01	1	1	1	1	1	1	1	1			
43	INSULATION - COMPRESSOR CENTER	VNN 2C1 (SOFT)	447120-01	1	1	1	1	1	1	1	1			
44	INSULATION - COMPRESSOR LEFT	VNN 2C1 (SOFT)	447121-01	1	1	1	1	1	1	1	1			
45	COPPER TUBE - CAPILLARY	COPPER	445174G02	1	1	1	1	1	1	1	1			
46	COPPER TUBE (A)	COPPER	2A0163G01	x1										
		COPPER	2A0421G01	o1	1	-								
		COPPER	2A0515G01				1	1	1	1	1			
47	COPPER TUBE (B)	COPPER	445176G01	1	1	1	1	1	1	1	1			
48	COPPER TUBE (C)	COPPER	4A0209G01	1	1	-								
		COPPER	4A0771G01				1	1	1	1	1			
49	HOLDER / EXPANSION VALVE - 3/8	SS	3A0107-01	2	2	2	2	2	2	2	2			

MODEL: KM-1600SWE TITLE: B. REFRIGERATION CIRCUIT												
INDEX NO.	DESCRIPTION	MATERIAL OR MODEL	PART NUMBER	REQUIRED NUMBER								
				D-0	E-0	E-1	F-0	F-1	G-0	H-0		
50	CLAMP	SS	443461-01	2	2	2	2	2	2	2		
51	INSULATION TUBE	L=40	7762-1020	5	5	5	5	5	5	5		
52	CABLE TIE	CV-200	7920-0010	13	13	13	13	13	13	13		
53	EXPANSION VALVE COVER (A)	PE FOAM	324214-01	2	2	2	2	2	2	2		
54	EXPANSION VALVE COVER (B)	PE FOAM	324214-02	2	2	2	2	2	2	2		
55	THERMISTOR	-	429006-03	1	1	1	1	1	1	1		
56	HOLDER - THERMISTOR	COPPER	438247-01	1	1	1	1	1	1	1		
57	INSULATION - THERMISTOR	PE FOAM	427441-01	1	1	1	1	1	1	1		
58	INSULATED RUBBER TUBE	EPDM	323975G01	1	1	1	1	1	1	1		
59	INSULATION	PE FOAM	436671-01	1	1	1	1	1	1	1		
60	INSULATION TUBE	L=150	7762-3555	1	1	1	1	1	1	1		
61	WIRE SADDLE	VWS4238-C	4A0338-02	3	3	3	3	3	3	3		
62	WASHER	SS	4A0655-03	3	3	3	3	3	3	3		

MODEL: KM-1600SWE3 TITLE: B. REFRIGERATION CIRCUIT													
INDEX NO.	DESCRIPTION	MATERIAL OR MODEL	PART NUMBER	REQUIRED NUMBER									
				D-0	E-0	F-1	G-1	H-0					
G	EVAPORATOR	-	104696A01	1	1	1	1	1					
1	REAR FRAME	GS	439285G03	1	1	-	-						
		GS	439285G04			1	1	1					
2	SIDE FRAME (A)	GS	219472G01	1	1	1	1	1					
3	SIDE FRAME (B)	GS	323901G01	1	1	1	1	1					
4	FRONT FRAME	GS	325857-01	1	1	1	1	1					
5	REAR PANEL (A)	GS	219569-01	1	1	-	-						
		GS	219569-02			1	1	1					
6	COMPRESSOR	M53A273DBDA	4A0333-02	1	1	1	1	1					
7	GROMMET	027-0167-00	434922-01	4	4	4	4	4					
8	SPACER	028-0188-02	434921-01	4	4	4	4	4					
9	BOLT	8 x 45	437889-01	4	4	4	4	4					
10	CONDENSER - WATER-COOLED	-	219382-01	1	1	1	1	1					
11	DRIER	C-530-S	445011-01	1	1	1	1	1					
12	DRIER BRACKET	GS	445251-01	1	1	1	1	1					
13	EXPANSION VALVE	HFE-15HHD-2	445542-01	2	2	2	2	2					
14	TERMINAL GASKET	-	334084-01	1	1	1	1	1					
15	FRAME SEAL	EPDM	323925-01	4	4	4	4	4					
16	HOT GAS VALVE BRACKET	GS	440507-01	1	1	1	1	1					
17	VALVE BODY	70	440352-01	2	2	2	2	2					
18	COIL - VALVE	ABS-25-1-HD-2	440353-01	2	2	2	2	2					
19	BOLT	4 x 6	440353F01	2	2	2	2	2					
20	LINE VALVE BRACKET	GS	438213-01	1	1	1	1	1					
21	VALVE BODY	24	440351-01	1	1	1	1	1					
22	COIL - VALVE	ADS-24HD-3	440354-01	1	1	1	1	1					
23	BOLT	4 x 6	440354F01	1	1	1	1	1					
24	THERMOSTAT	US-602SXTTBL	445595-01	1	1	1	1	1					
25	PRESSURE SWITCH	ACB-2UB02	433441-01	1	1	1	1	1					
26	PRESSURE SWITCH BRACKET	GS	434938-01	1	1	1	1	1					

MODEL: KM-1600SWE3 TITLE: B. REFRIGERATION CIRCUIT													
INDEX NO.	DESCRIPTION	MATERIAL OR MODEL	PART NUMBER	REQUIRED NUMBER									
				D-0	E-0	F-1	G-1	H-0					
27	COPPER TUBE - ACCESS VALVE	COPPER	439761-02	1	1	1	1	1					
28	ACCESS VALVE	TCJ-2F15-HD	417366-01	2	2	2	2	2					
29	STRAINER	-	441569-02	1	1	1	1	1					
30	CHECK VALVE	YCV5-2	425342-01	2	2	2	2	2					
31	WATER REGULATOR BRCKT.	GS	445172-01	1	1	1	1	1					
32	WATER REGULATOR ASSEMBLY	(S-0815)	446716G01	1	1	1	1	1					
33	COPPER TUBE (A) - HIGH SIDE	COPPER	219470G01	1	1	1	1	1					
34	COPPER TUBE (B) - HIGH SIDE	COPPER	331186-01	1	1	1	1	1					
35	COPPER TUBE (C) - HIGH SIDE	COPPER	446548G01	1	1	1	1	1					
36	COPPER TUBE (F) - HIGH SIDE	COPPER	219590G01	1	1	1	1	1					
37	HEAT EXCHANGER	COPPER	106498G01	1	1	1	1	1					
38	COPPER TUBE (R) - HIGH SIDE	COPPER	219591G01	1	1	1	1	1					
39	COPPER TUBE (L) - LOW SIDE	COPPER	219593G01	1	1	1	1	1					
40	COPPER TUBE - HOT GAS	COPPER	3A0212G01	1	1	1	1	1					
41	INSULATION - COMPRESSOR TOP	VNN 2C1 (SOFT)	447118-01	1	1	1	1	1					
42	INSULATION - COMPRESSOR RIGHT	VNN 2C1 (SOFT)	447119-01	1	1	1	1	1					
43	INSULATION - COMPRESSOR CENTER	VNN 2C1 (SOFT)	447120-01	1	1	1	1	1					
44	INSULATION - COMPRESSOR LEFT	VNN 2C1 (SOFT)	447121-01	1	1	1	1	1					
45	COPPER TUBE - CAPILLARY	COPPER	445174G01	1	1	1	1	1					
46	COPPER TUBE (A)	COPPER	2A0163G01	x1									
		COPPER	2A0421G01	o1	1	-							
		COPPER	2A0515G01			1	1	1					
47	COPPER TUBE (B)	COPPER	445176G01	1	1	1	1	1					
48	COPPER TUBE (C)	COPPER	4A0209G01	1	1	-							
		COPPER	4A0771G01			1	1	1					

MODEL: KM-1600SWE3 TITLE: B. REFRIGERATION CIRCUIT													
INDEX NO.	DESCRIPTION	MATERIAL OR MODEL	PART NUMBER	REQUIRED NUMBER									
				D-0	E-0	F-1	G-1	H-0					
49	HOLDER / EXPANSION VALVE - 3/8	SS	3A0107-01	2	2	2	2	2					
50	CLAMP	SS	443461-01	2	2	2	2	2					
51	INSULATION TUBE	L=40	7762-1020	5	5	5	5	5					
52	CABLE TIE	CV-200	7920-0010	13	13	13	13	13					
53	EXPANSION VALVE COVER (A)	PE FOAM	324214-01	2	2	2	2	2					
54	EXPANSION VALVE COVER (B)	PE FOAM	324214-02	2	2	2	2	2					
55	THERMISTOR	-	429006-03	1	1	1	1	1					
56	HOLDER - THERMISTOR	COPPER	438247-01	1	1	1	1	1					
57	INSULATION - THERMISTOR	PE FOAM	427441-01	1	1	1	1	1					
58	INSULATED RUBBER TUBE	EPDM	323975G01	1	1	1	1	1					
59	INSULATION	PE FOAM	436671-01	1	1	1	1	1					
60	INSULATION TUBE	L=150	7762-3555	1	1	1	1	1					
61	WIRE SADDLE	VWS4238-C	4A0338-02	3	3	3	3	3					
62	WASHER 3	SS	4A0655-03	3	3	3	3	3					

HA

KM-1600SRE/SRE3

B. REFRIGERATION CIRCUIT (1/2)

D-0, E-0, E-1, F-0, F-1,
G-0, G-1, G-2, H-0, H-1

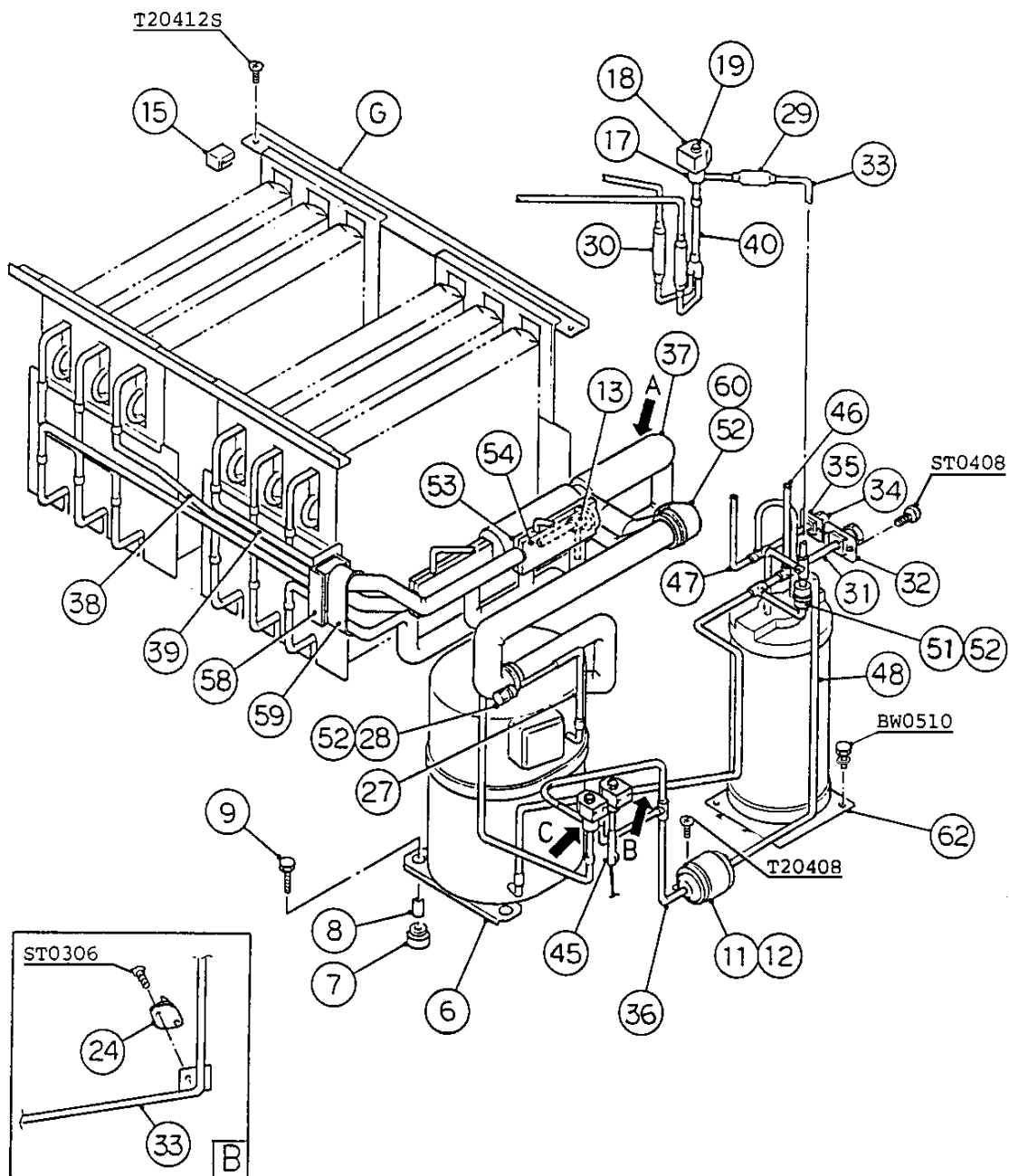
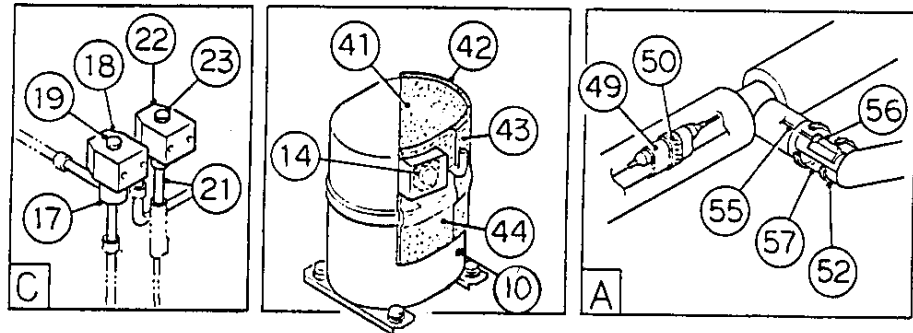

HA

KM-1600SRE/SRE3

B. REFRIGERATION CIRCUIT (2/2)

D-0, E-0, E-1, F-0, F-1,
G-0, G-1, G-2, H-0, H-1

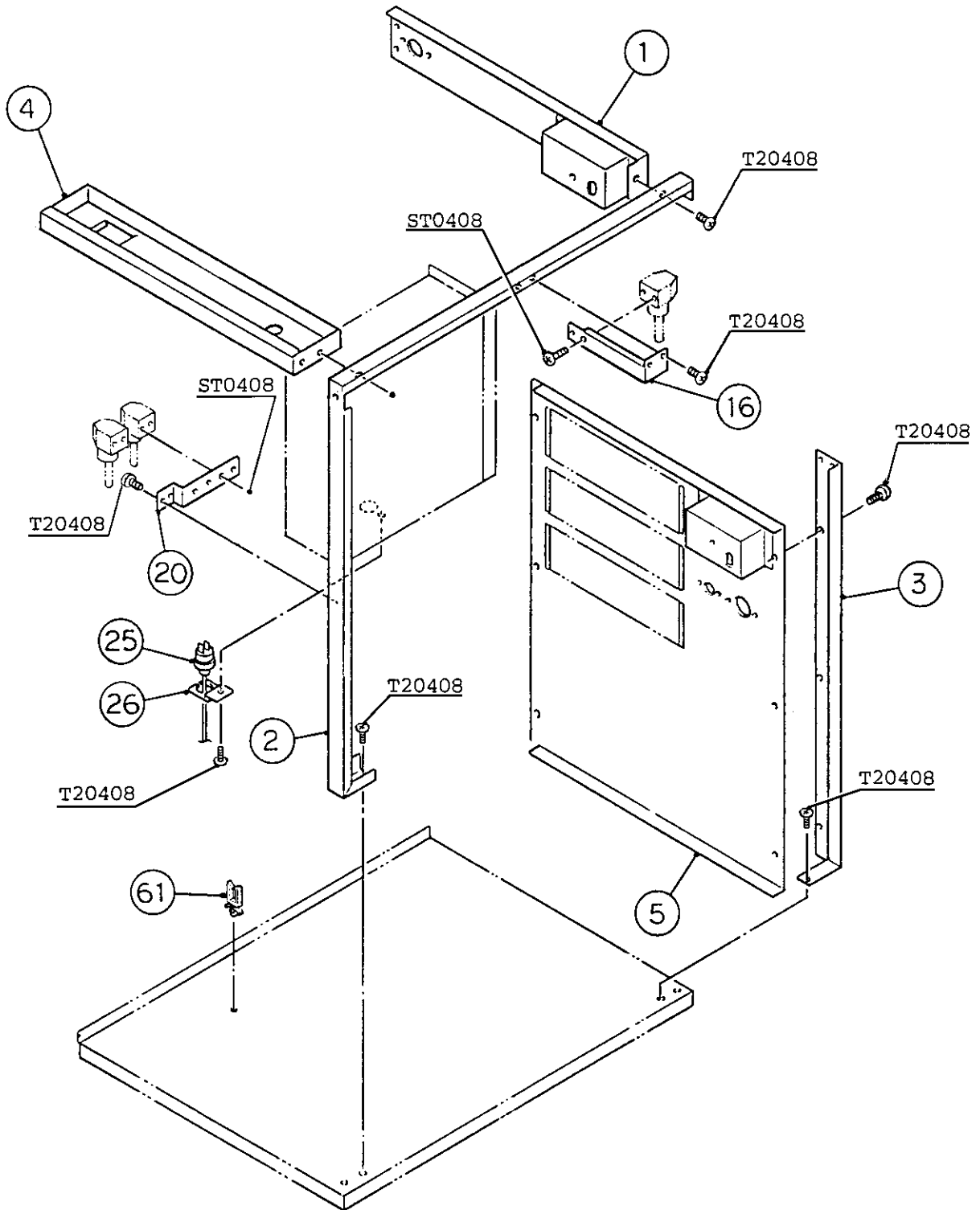

MODEL: KM-1600SRE TITLE: B. REFRIGERATION CIRCUIT													
INDEX NO.	DESCRIPTION	MATERIAL OR MODEL	PART NUMBER	REQUIRED NUMBER									
				D-0	E-0	E-1	F-0	F-1	G-0	G-1	G-2	H-0	H-1
G	EVAPORATOR	-	104696A01	1	1	1	1	1	1	1	1	1	1
1	REAR FRAME	GS	439285G03	1	1	-							
		GS	439285G04			1	1	1	1	1	1	1	1
2	SIDE FRAME (A)	GS	219472G01	1	1	1	1	1	1	1	1	1	1
3	SIDE FRAME (B)	GS	323901G01	1	1	1	1	1	1	1	1	1	1
4	FRONT FRAME	GS	325857-01	1	1	1	1	1	1	1	1	1	1
5	REAR PANEL (A)	GS	215100G01	1	1	1	1	1	1	1	1	1	1
6	COMPRESSOR	H23A463ABCA	438202-02	1	1	1	1	1	1	1	1	1	1
7	GROMMET	027-0167-00	434922-01	4	4	4	4	4	4	4	4	4	4
8	SPACER	028-0188-02	434921-01	4	4	4	4	4	4	4	4	4	4
9	BOLT	8 x 45	437889-01	4	4	4	4	4	4	4	4	4	4
10	CRANKCASE HEATER	T.I.8HT5-505	438208-01	1	1	1	1	1	1	1	1	1	1
11	DRIER	C-530-S	445011-01	1	1	1	1	1	1	1	1	1	1
12	DRIER BRACKET	GS	445251-01	1	1	1	1	1	1	1	1	1	1
13	EXPANSION VALVE	HFE-15HHD-2	445542-01	2	2	2	2	2	2	2	2	2	2
14	TERMINAL GASKET	-	334084-01	1	1	1	1	1	1	1	1	1	1
15	FRAME SEAL	EPDM	323925-01	4	4	4	4	4	4	4	4	4	4
16	HOT GAS VALVE BRACKET	GS	440507-01	1	1	1	1	1	1	1	1	1	1
17	VALVE BODY	70	440352-01	2	2	2	2	2	2	2	2	2	2
18	COIL - VALVE	ABS-25-1-HD-2	440353-01	2	2	2	2	2	2	2	2	2	2
19	BOLT	4 x 6	440353F01	2	2	2	2	2	2	2	2	2	2
20	LINE VALVE BRACKET	GS	438213-01	1	1	1	1	1	1	1	1	1	1
21	VALVE BODY	24	440351-01	1	1	1	1	1	1	1	1	1	1
22	COIL - VALVE	ADS-24HD-3	440354-01	1	1	1	1	1	1	1	1	1	1
23	BOLT	4 x 6	440354F01	1	1	1	1	1	1	1	1	1	1
24	THERMOSTAT	US-602SXTTBL	445595-01	1	1	1	1	1	1	1	1	1	1
25	PRESSURE SWITCH	ACB-2UB04	433441-05	1	1	1	1	1	1	1	1	1	1
26	PRESSURE SWITCH BRCKT.	GS	434938-01	1	1	1	1	1	1	1	1	1	1
27	COPPER TUBE - ACCESS VALVE	COPPER	439761-02	1	1	1	1	1	1	1	1	1	1
28	ACCESS VALVE	TCJ-2F15-HD	417366-01	1	1	1	1	1	1	1	1	1	1

MODEL: KM-1600SRE TITLE: B. REFRIGERATION CIRCUIT													
INDEX NO.	DESCRIPTION	MATERIAL OR MODEL	PART NUMBER	REQUIRED NUMBER									
				D-0	E-0	E-1	F-0	F-1	G-0	G-1	G-2	H-0	H-1
29	STRAINER	-	441569-02	1	1	1	1	1	1	1	1	1	1
30	CHECK VALVE	YCV5-2	425342-01	2	2	2	2	2	2	2	2	2	2
31	COUPLING	COPPER	434136G01	1	1	1	1	1	1	1	1	1	1
32	TUBE HOLDER - L	GS	438245-01	1	1	1	1	1	1	1	1	1	1
33	COPPER TUBE (A) - HIGH SIDE	COPPER	219470G02	1	1	1	1	1	1	1	1	1	1
34	COUPLING	COPPER	433751G01	1	1	1	1	1	1	1	1	1	1
35	TUBE HOLDER - S	GS	438246-01	1	1	1	1	1	1	1	1	1	1
36	COPPER TUBE (F) - HIGH SIDE	COPPER	219590G01	1	1	1	1	1	1	1	1	1	1
37	HEAT EXCHANGER	COPPER	106498G01	1	1	1	1	1	1	1	1	1	1
38	COPPER TUBE (R) - HIGH SIDE	COPPER	219591G01	1	1	1	1	1	1	1	1	1	1
39	COPPER TUBE (L) - LOW SIDE	COPPER	219593G01	1	1	1	1	1	1	1	1	1	1
40	COPPER TUBE - HOT GAS	COPPER	3A0212G01	1	1	1	1	1	1	1	1	1	1
41	INSULATION - COMPRESSOR TOP	VNN 2C1 (SOFT)	447118-01	1	1	1	1	1	1	1	1	1	1
42	INSULATION - COMPRESSOR RIGHT	VNN 2C1 (SOFT)	447119-01	1	1	1	1	1	1	1	1	1	1
43	INSULATION - COMPRESSOR CENTER	VNN 2C1 (SOFT)	447120-01	1	1	1	1	1	1	1	1	1	1
44	INSULATION - COMPRESSOR LEFT	VNN 2C1 (SOFT)	447121-01	1	1	1	1	1	1	1	1	1	1
45	COPPER TUBE - CAPILLARY	COPPER	445174G03	1	1	1	1	1	1	1	1	1	1
46	COPPER TUBE (B) - HIGH SIDE	COPPER	445423G01	1	1	1	1	1	1	1	1	1	1
47	COPPER TUBE (D) - HIGH SIDE	COPPER	331185G01	1	1	1	1	1	1	1	1	1	1
48	COPPER TUBE (E) - HIGH SIDE	COPPER	332463-01	1	1	1	1	1	1	1	1	1	1
49	HOLDER / EXP. VALVE - 3/8	SS	3A0107-01	2	2	2	2	2	2	2	2	2	2
50	CLAMP	SS	443461-01	2	2	2	2	2	2	2	2	2	2
51	INSULATION TUBE	L=40	7762-1020	3	3	3	3	3	3	3	3	3	3
52	CABLE TIE	CV-200	7920-0010	11	11	11	11	11	11	11	11	11	11
53	EXPANSION VALVE COVER (A)	PE FOAM	324214-01	2	2	2	2	2	2	2	2	2	2
54	EXPANSION VALVE COVER (B)	PE FOAM	324214-02	2	2	2	2	2	2	2	2	2	2

MODEL: KM-1600SRE TITLE: B. REFRIGERATION CIRCUIT													
INDEX NO.	DESCRIPTION	MATERIAL OR MODEL	PART NUMBER	REQUIRED NUMBER									
				D-0	E-0	E-1	F-0	F-1	G-0	G-1	G-2	H-0	H-1
55	THERMISTOR	-	429006-03	1	1	1	1	1	1	1	1	1	1
56	HOLDER - THERMISTOR	COPPER	438247-01	1	1	1	1	1	1	1	1	1	1
57	INSULATION - THERMISTOR	PE FOAM	427441-01	1	1	1	1	1	1	1	1	1	1
58	INSULATED RUBBER TUBE	EPDM	323975G01	1	1	1	1	1	1	1	1	1	1
59	INSULATION	PE FOAM	436671-01	1	1	1	1	1	1	1	1	1	1
60	INSULATION TUBE	L=150	7762-3555	1	1	1	1	1	1	1	1	1	1
61	WIRE SADDLE	VWS4238-C	4A0338-02	3	3	3	3	3	3	3	3	3	3
62	RECEIVER	RR MN WP450	438209-01	1	1	1	1	1	1	1	1	1	1

MODEL: KM-1600SRE3 TITLE: B. REFRIGERATION CIRCUIT														
INDEX NO.	DESCRIPTION	MATERIAL OR MODEL	PART NUMBER	REQUIRED NUMBER										
				D-0	E-0	E-1	F-0	F-1	G-0	G-1	H-0			
G	EVAPORATOR	-	104696A01	1	1	1	1	1	1	1	1	1		
1	REAR FRAME	GS	439285G03	1	1	-			-					
		GS	439285G04			1	1	1	1	1	1	1		
2	SIDE FRAME (A)	GS	219472G01	1	1	1	1	1	1	1	1	1		
3	SIDE FRAME (B)	GS	323901G01	1	1	1	1	1	1	1	1	1		
4	FRONT FRAME	GS	325857-01	1	1	1	1	1	1	1	1	1		
5	REAR PANEL (A)	GS	215100G01	1	1	1	1	1	1	1	1	1		
6	COMPRESSOR	M53A273DBDA	4A0333-01	1	1	1	1	1	1	1	1	1		
7	GROMMET	027-0167-00	434922-01	4	4	4	4	4	4	4	4	4		
8	SPACER	028-0188-02	434921-01	4	4	4	4	4	4	4	4	4		
9	BOLT	8 x 45	437889-01	4	4	4	4	4	4	4	4	4		
10	CRANKCASE HEATER	T.1.8HT5-505	438208-01	1	1	1	1	1	1	1	1	1		
11	DRIER	C-530-S	445011-01	1	1	1	1	1	1	1	1	1		
12	DRIER BRACKET	GS	445251-01	1	1	1	1	1	1	1	1	1		
13	EXPANSION VALVE	HFE-15HHD-2	445542-01	2	2	2	2	2	2	2	2	2		
14	TERMINAL GASKET	-	334084-01	1	1	1	1	1	1	1	1	1		
15	FRAME SEAL	EPDM	323925-01	4	4	4	4	4	4	4	4	4		
16	HOT GAS VALVE BRACKET	GS	440507-01	1	1	1	1	1	1	1	1	1		
17	VALVE BODY	70	440352-01	2	2	2	2	2	2	2	2	2		
18	COIL - VALVE	ABS-25-1-HD-2	440353-01	2	2	2	2	2	2	2	2	2		
19	BOLT	4 x 6	440353F01	2	2	2	2	2	2	2	2	2		
20	LINE VALVE BRACKET	GS	438213-01	1	1	1	1	1	1	1	1	1		
21	VALVE BODY	24	440351-01	1	1	1	1	1	1	1	1	1		
22	COIL - VALVE	ADS-24HD-3	440354-01	1	1	1	1	1	1	1	1	1		
23	BOLT	4 x 6	440354F01	1	1	1	1	1	1	1	1	1		
24	THERMOSTAT	US-602SXTTBL	445595-01	1	1	1	1	1	1	1	1	1		
25	PRESSURE SWITCH	ACB-2UB04	433441-05	1	1	1	1	1	1	1	1	1		
26	PRESSURE SWITCH BRCKT.	GS	434938-01	1	1	1	1	1	1	1	1	1		
27	COPPER TUBE - ACCESS VALVE	COPPER	439761-02	1	1	1	1	1	1	1	1	1		
28	ACCESS VALVE	TCJ-2F15-HD	417366-01	1	1	1	1	1	1	1	1	1		

MODEL: KM-1600SRE3 TITLE: B. REFRIGERATION CIRCUIT													
INDEX NO.	DESCRIPTION	MATERIAL OR MODEL	PART NUMBER	REQUIRED NUMBER									
				D-0	E-0	E-1	F-0	F-1	G-0	G-1	H-0		
29	STRAINER	-	441569-02	1	1	1	1	1	1	1	1	1	
30	CHECK VALVE	YCV5-2	425342-01	2	2	2	2	2	2	2	2	2	
31	COUPLING	COPPER	434136G01	1	1	1	1	1	1	1	1	1	
32	TUBE HOLDER - L	GS	438245-01	1	1	1	1	1	1	1	1	1	
33	COPPER TUBE (A) - HIGH SIDE	COPPER	219470G02	1	1	1	1	1	1	1	1	1	
34	COUPLING	COPPER	433751G01	1	1	1	1	1	1	1	1	1	
35	TUBE HOLDER - S	GS	438246-01	1	1	1	1	1	1	1	1	1	
36	COPPER TUBE (F) - HIGH SIDE	COPPER	219590G01	1	1	1	1	1	1	1	1	1	
37	HEAT EXCHANGER	COPPER	106498G01	1	1	1	1	1	1	1	1	1	
38	COPPER TUBE (R) - HIGH SIDE	COPPER	219591G01	1	1	1	1	1	1	1	1	1	
39	COPPER TUBE (L) - LOW SIDE	COPPER	219593G01	1	1	1	1	1	1	1	1	1	
40	COPPER TUBE - HOT GAS	COPPER	3A0212G01	1	1	1	1	1	1	1	1	1	
41	INSULATION - COMPRESSOR TOP	VNN 2C1 (SOFT)	447118-01	1	1	1	1	1	1	1	1	1	
42	INSULATION - COMPRESSOR RIGHT	VNN 2C1 (SOFT)	447119-01	1	1	1	1	1	1	1	1	1	
43	INSULATION - COMPRESSOR CENTER	VNN 2C1 (SOFT)	447120-01	1	1	1	1	1	1	1	1	1	
44	INSULATION - COMPRESSOR LEFT	VNN 2C1 (SOFT)	447121-01	1	1	1	1	1	1	1	1	1	
45	COPPER TUBE - CAPILLARY	COPPER	445174G02	1	1	1	1	1	1	1	1	1	
46	COPPER TUBE (B) - HIGH SIDE	COPPER	445423G01	1	1	1	1	1	1	1	1	1	
47	COPPER TUBE (D) - HIGH SIDE	COPPER	331185G01	1	1	1	1	1	1	1	1	1	
48	COPPER TUBE (E) - HIGH SIDE	COPPER	332463-01	1	1	1	1	1	1	1	1	1	
49	HOLDER / EXP. VALVE - 3/8	SS	3A0107-01	2	2	2	2	2	2	2	2	2	
50	CLAMP	SS	443461-01	2	2	2	2	2	2	2	2	2	
51	INSULATION TUBE	L=40	7762-1020	3	3	3	3	3	3	3	3	3	
52	CABLE TIE	CV-200	7920-0010	11	11	11	11	11	11	11	11	11	
53	EXPANSION VALVE COVER (A)	PE FOAM	324214-01	2	2	2	2	2	2	2	2	2	
54	EXPANSION VALVE COVER (B)	PE FOAM	324214-02	2	2	2	2	2	2	2	2	2	

MODEL: KM-1600SRE3 TITLE: B. REFRIGERATION CIRCUIT														
INDEX NO.	DESCRIPTION	MATERIAL OR MODEL	PART NUMBER	REQUIRED NUMBER										
				D-0	E-0	E-1	F-0	F-1	G-0	G-1	H-0			
55	THERMISTOR	-	429006-03	1	1	1	1	1	1	1	1	1		
56	HOLDER - THERMISTOR	COPPER	438247-01	1	1	1	1	1	1	1	1	1		
57	INSULATION - THERMISTOR	PE FOAM	427441-01	1	1	1	1	1	1	1	1	1		
58	INSULATED RUBBER TUBE	EPDM	323975G01	1	1	1	1	1	1	1	1	1		
59	INSULATION	PE FOAM	436671-01	1	1	1	1	1	1	1	1	1		
60	INSULATION TUBE	L=150	7762-3555	1	1	1	1	1	1	1	1	1		
61	WIRE SADDLE	VWS4238-C	4A0338-02	3	3	3	3	3	3	3	3	3		
62	RECEIVER	RR MN WP450	438209-01	1	1	1	1	1	1	1	1	1		

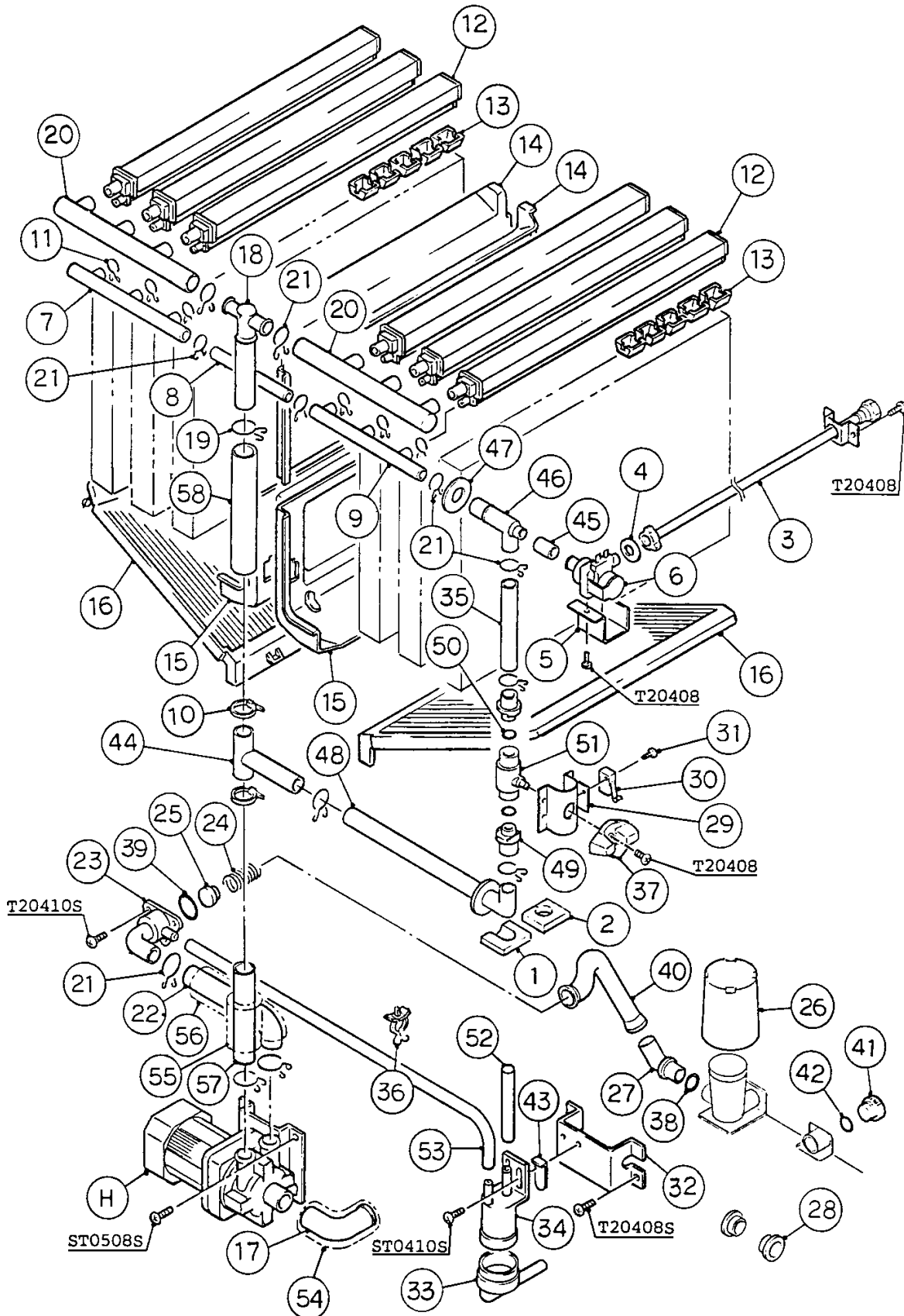

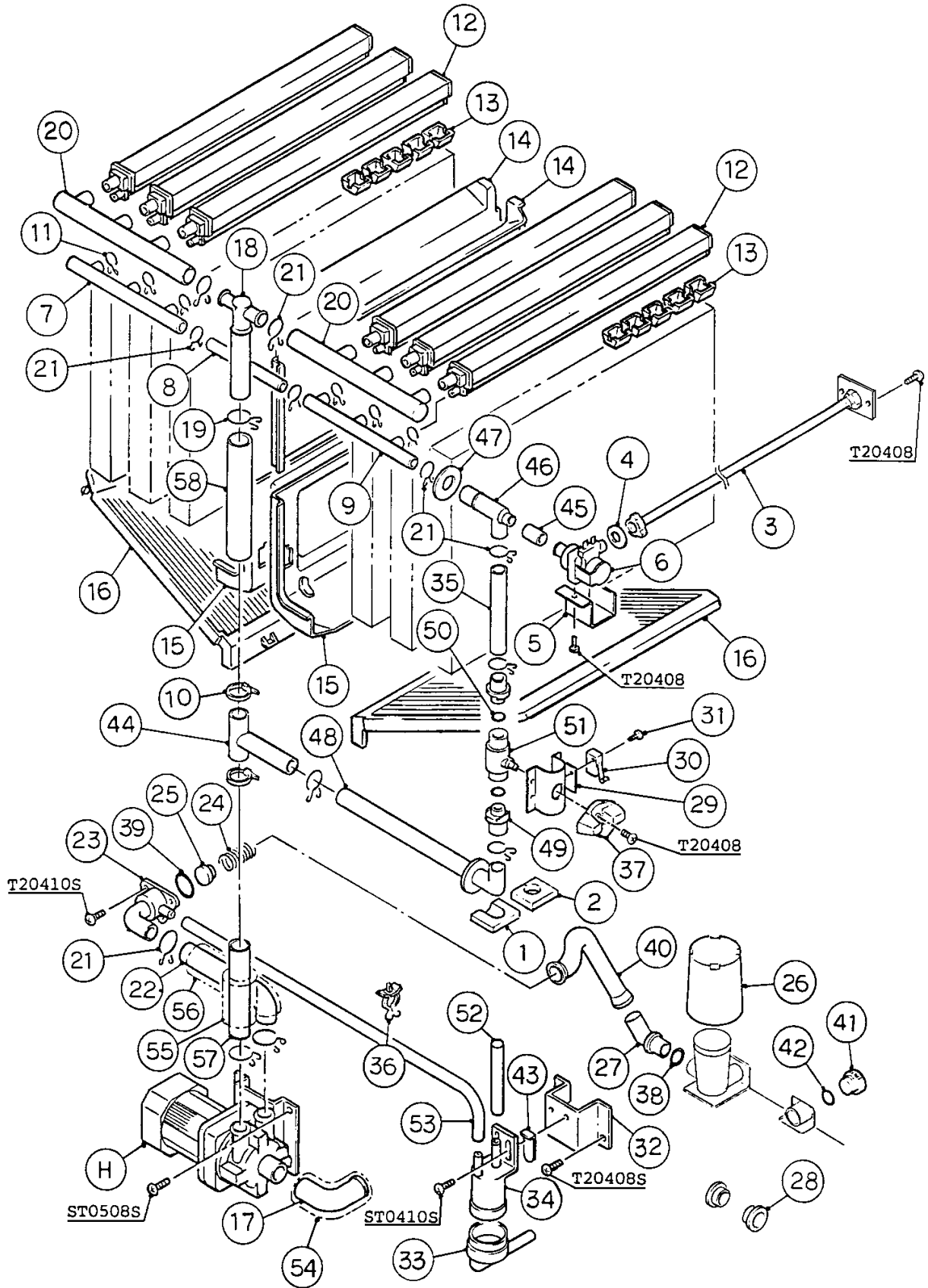

MODEL: KM-1600SWE TITLE: C. WATER CIRCUIT												
INDEX NO.	DESCRIPTION	MATERIAL OR MODEL	PART NUMBER	REQUIRED NUMBER								
				D-0	E-0	E-1	F-0	F-1	G-0	H-0		
H	PUMP MOTOR ASSEMBLY	(S-0730)	215692A01	1	1	1	1	1	1	1	1	
1	CORNER INSULATION (A)	PE FOAM	439376-01	1	1	1	1	1	1	1	1	
2	CORNER INSULATION (B)	PE FOAM	439392-01	1	1	1	1	1	1	1	1	
3	WATER SUPPLY PIPE	COPPER	4A0207G01	1	1	-						
		COPPER	4A0768G01			1	1	1	1	1	1	
4	RUBBER GASKET	NR	413854-01	1	1	x1						
		SI. R	413854-03			o1	1	1	1	1	1	
5	WATER VALVE BRACKET	GS	321443-01	1	1	1	1	1	1	1	1	
6	WATER VALVE	J248-030	3U0111-01	1	1	1	1	1	1	1	1	
7	DISTRIBUTOR HOSE (A)	EPDM	325738-01	1	1	1	1	1	1	1	1	
8	JOINT PIPE	ABS	439297-01	1	1	1	1	1	1	1	1	
9	DISTRIBUTOR HOSE (B)	EPDM	325738-02	1	1	1	1	1	1	1	1	
10	CABLE TIE	CV-200	7920-0010	3	3	3	3	3	3	3	3	
11	HOSE CLAMP	SS, 13.5 mm.	427443-07	6	6	6	6	6	6	6	6	
12	SPRAY TUBE	ABS	437049G01	6	6	6	6	6	6	6	6	
13	SPRAY GUIDE (A)	PE	208586-01	18	18	18	18	18	18	18	18	
14	SEPARATOR (A)	ABS	213622-01	2	2	2	2	2	2	2	2	
15	SEPARATOR (B)	ABS	2A0100-01	2	2	2	2	2	2	2	2	
16	CUBE GUIDE	ABS	214243-01	2	2	2	2	2	2	2	2	
17	HOSE (A)	EPDM	435091-01	1	1	1	1	1	1	1	1	
18	DISTRIBUTOR	ABS	438276G01	1	1	1	1	1	1	1	1	
19	HOSE CLAMP	SS, 32 mm.	427443-09	2	2	2	2	2	2	2	2	
20	DISTRIBUTOR HOSE (C)	EPDM	323985-01	2	2	2	2	2	2	2	2	
21	HOSE CLAMP	SS, 25 mm.	427443-03	11	11	11	11	11	11	11	11	
22	HOSE (B)	EPDM	436599-01	1	1	1	1	1	1	1	1	
23	VALVE HOUSING - DRAIN	ABS	323613-01	1	1	1	1	1	1	1	1	
24	SPRING	SS	322685-01	1	1	1	1	x1				
		SS	322110-01					o1	1	1	1	
25	VALVE SHEET	EPDM	433705-01	1	1	1	1	1	1	1	1	
26	OVERFLOW CAP	PE	323978-01	1	1	1	1	1	1	1	1	

MODEL: KM-1600SWE TITLE: C. WATER CIRCUIT													
INDEX NO.	DESCRIPTION	MATERIAL OR MODEL	PART NUMBER	REQUIRED NUMBER									
				D-0	E-0	E-1	F-0	F-1	G-0	H-0			
27	JOINT - OVERFLOW	ABS	323923-02	1	1	1	1	1	1	1	1		
28	BUSHING	SB-1093-15	420470-03	2	2	2	2	2	2	2	x2		
		-	420470-06								o2		
29	VALVE HOLDER	GS	325825-01	1	1	1	1	1	1	1	1		
30	MICRO SWITCH	V3L-111-08	4A0365-01	1	1	1	1	1	1	1	1		
31	TAPPING SCREW	3 x 14	431415-02	2	2	2	2	2	2	2	2		
32	FLOAT SWITCH BRACKET	SS	323906-01	1	1	-							
		SS	3A0449-01			1	1	1	1	1	1		
33	CONNECTOR - FLOAT SWITCH	EPDM	426799-04	1	1	1	1	1	1	1	1		
34	FLOAT SWITCH	FS-0893B-1	433535-02	1	1	1	x1						
		163795	4A0886-01				o1	1	1	1	1		
35	JOINT HOSE	EPDM	439309-02	1	1	1	1	1	1	1	1		
36	CLAMP	No. 4253	427902-05	1	1	1	1	1	1	1	1		
37	HANDLE	JH1352	215383-01	1	1	1	1	1	1	1	1		
38	"O" RING	1AP18	7611-P018	1	1	1	1	1	1	1	1		
39	"O" RING	1AG35	7611-G035	1	1	1	1	1	1	1	1		
40	DRAIN HOSE	EPDM	324757-01	1	1	1	1	1	1	1	1		
41	DRAIN	AC	309246-01	1	1	1	1	1	1	1	1		
42	"O" RING	1AP15	7611-P015	1	1	1	1	1	1	1	1		
43	FLOAT SWITCH STOP	SS	4A0137-01	1	1	1	1	1	1	1	1		
44	DISTRIBUTOR (C)	ABS	439238-01	1	1	1	1	1	1	1	1		
45	JOINT HOSE	EPDM	439296-01	1	1	1	1	1	1	1	1		
46	DISTRIBUTOR (B)	ABS	439239-01	1	1	1	1	1	1	1	1		
47	FLANGE	EPDM	439267-02	1	1	1	1	1	1	1	1		
48	BYPASS HOSE	SANTOPRENE	439237-02	1	1	1	1	1	1	1	1		
49	MALE ADAPTOR	ABS	325826-01	2	2	2	2	2	2	2	2		
50	"O" RING	1AP18	7611-P018	2	2	2	2	2	2	2	2		
51	BALL VALVE	PVC	439293-01	1	1	1	1	1	1	1	1		
52	VINYL HOSE	L=140	7716-0913	1	1	1	1	1	1	1	x1		
	SILICONE HOSE	L=140	773013812								o1		

MODEL: **KM-1600SWE** TITLE: **C. WATER CIRCUIT**

INDEX NO.	DESCRIPTION	MATERIAL OR MODEL	PART NUMBER	REQUIRED NUMBER										
				D-0	E-0	E-1	F-0	F-1	G-0	H-0				
53	VINYL HOSE	L=390	7716-0913	1	1	1	1	1	1	1	x1			
	SILICONE HOSE	L=390	7730I3812								o1			
54	INSULATION HOSE	L=120	7762-3555	1	1	1	1	1	1	1	1			
55	INSULATION HOSE	L=80	7962-3555	1	1	1	1	1	1	1	1			
56	INSULATION HOSE	L=150	7962-3555	1	1	1	1	1	1	1	1			
57	VINYL HOSE	L=170	7716-2732	1	1	1	1	1	1	1	1			
58	VINYL HOSE	L=230	7716-2732	1	1	1	1	1	1	1	1			

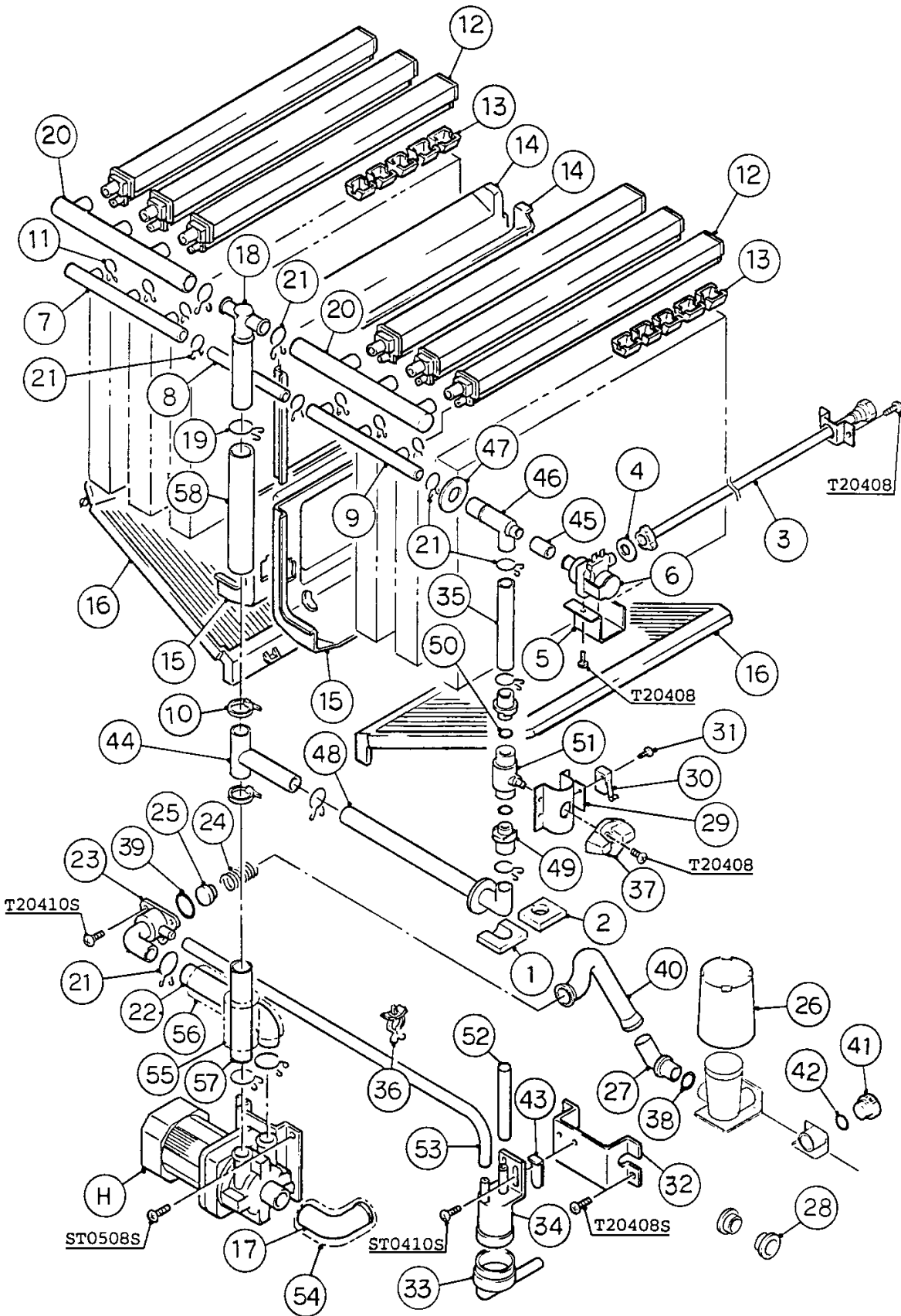

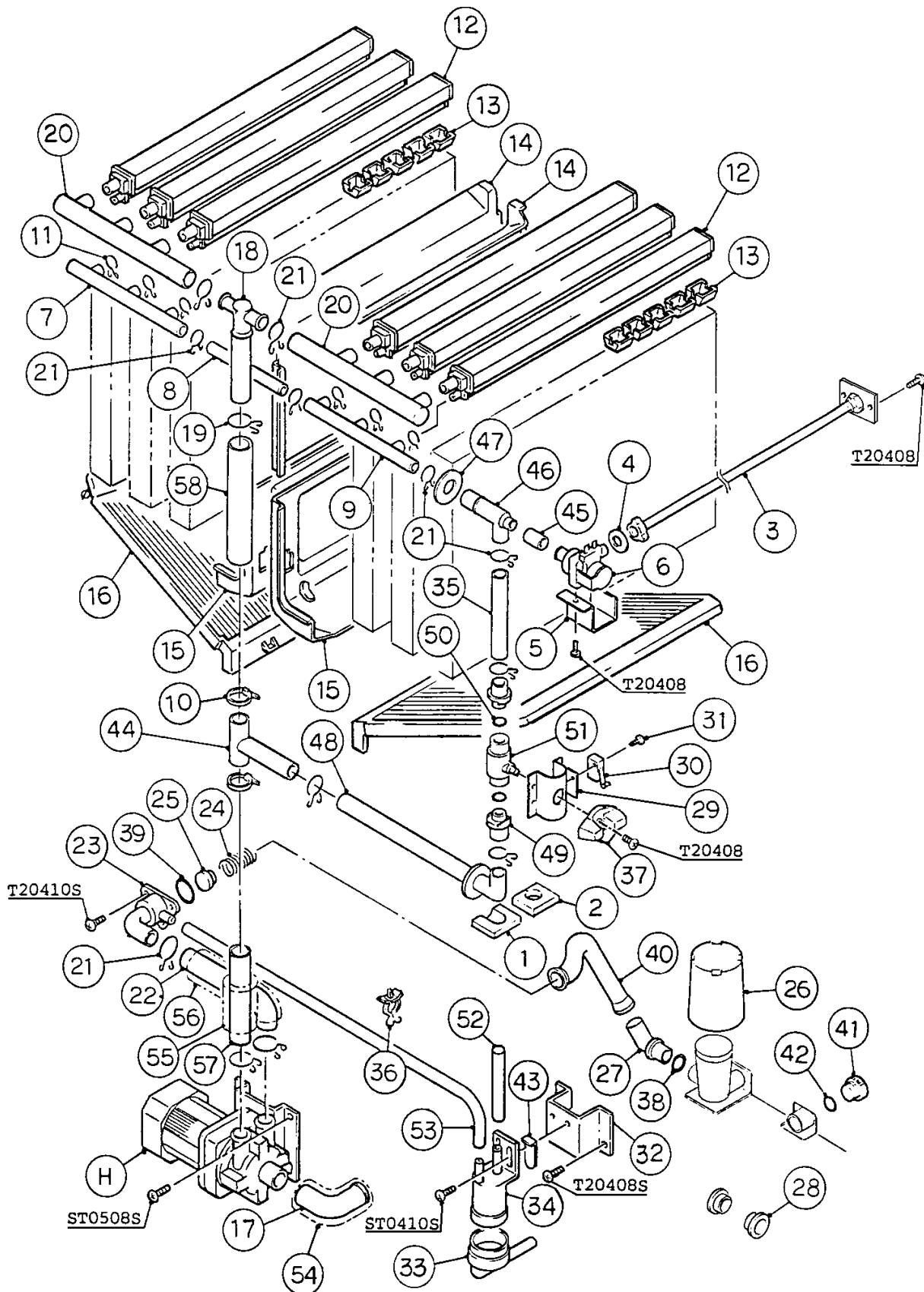

MODEL: KM-1600SWE3 TITLE: C. WATER CIRCUIT													
INDEX NO.	DESCRIPTION	MATERIAL OR MODEL	PART NUMBER	REQUIRED NUMBER									
				D-0	E-0	F-1	G-1	H-0					
H	PUMP MOTOR ASSEMBLY	(S-0730)	215692A01	1	1	1	1	1					
1	CORNER INSULATION (A)	PE FOAM	439376-01	1	1	1	1	1					
2	CORNER INSULATION (B)	PE FOAM	439392-01	1	1	1	1	1					
3	WATER SUPPLY PIPE	COPPER	4A0207G01	1	1	-							
		COPPER	4A0768G01			1	1	1					
4	RUBBER GASKET	NR	413854-01	1	1	x1							
		SI. R	413854-03			o1	1	1					
5	WATER VALVE BRACKET	GS	321443-01	1	1	1	1	1					
6	WATER VALVE	J248-030	3U0111-01	1	1	1	1	1					
7	DISTRIBUTOR HOSE (A)	EPDM	325738-01	1	1	1	1	1					
8	JOINT PIPE	ABS	439297-01	1	1	1	1	1					
9	DISTRIBUTOR HOSE (B)	EPDM	325738-02	1	1	1	1	1					
10	CABLE TIE	CV-200	7920-0010	3	3	3	3	3					
11	HOSE CLAMP	SS, 13.5 mm.	427443-07	6	6	6	6	6					
12	SPRAY TUBE	ABS	437049G01	6	6	6	6	6					
13	SPRAY GUIDE (A)	PE	208586-01	18	18	18	18	18					
14	SEPARATOR (A)	ABS	213622-01	2	2	2	2	2					
15	SEPARATOR (B)	ABS	2A0100-01	2	2	2	2	2					
16	CUBE GUIDE	ABS	214243-01	2	2	2	2	2					
17	HOSE (A)	EPDM	435091-01	1	1	1	1	1					
18	DISTRIBUTOR	ABS	438276G01	1	1	1	1	1					
19	HOSE CLAMP	SS, 32 mm.	427443-09	2	2	2	2	2					
20	DISTRIBUTOR HOSE (C)	EPDM	323985-01	2	2	2	2	2					
21	HOSE CLAMP	SS, 25 mm.	427443-03	11	11	11	11	11					
22	HOSE (B)	EPDM	436599-01	1	1	1	1	1					
23	VALVE HOUSING - DRAIN	ABS	323613-01	1	1	1	1	1					
24	SPRING	SS	322685-01	1	1	1	x1						
		SS	322110-01				o1	1					
25	VALVE SHEET	EPDM	433705-01	1	1	1	1	1					
26	OVERFLOW CAP	PE	323978-01	1	1	1	1	1					

MODEL: KM-1600SWE3 TITLE: C. WATER CIRCUIT													
INDEX NO.	DESCRIPTION	MATERIAL OR MODEL	PART NUMBER	REQUIRED NUMBER									
				D-0	E-0	F-1	G-1	H-0					
27	JOINT - OVERFLOW	ABS	323923-02	1	1	1	1	1					
28	BUSHING	SB-1093-15	420470-03	2	2	2	2	x2					
		-	420470-06					o2					
29	VALVE HOLDER	GS	325825-01	1	1	1	1	1					
30	MICRO SWITCH	V3L-111-08	4A0365-01	1	1	1	1	1					
31	TAPPING SCREW	3 x 14	431415-02	2	2	2	2	2					
32	FLOAT SWITCH BRACKET	SS	323906-01	1	1	-							
		SS	3A0449-01			1	1	1					
33	CONNECTOR - FLOAT SWITCH	EPDM	426799-04	1	1	1	1	1					
34	FLOAT SWITCH	FS-0893B-1	433535-02	1	1	x1							
		163795	4A0886-01			o1	1	1					
35	JOINT HOSE	EPDM	439309-02	1	1	1	1	1					
36	CLAMP	No. 4253	427902-05	1	1	1	1	1					
37	HANDLE	JH1352	215383-01	1	1	1	1	1					
38	"O" RING	1AP18	7611-P018	1	1	1	1	1					
39	"O" RING	1AG35	7611-G035	1	1	1	1	1					
40	DRAIN HOSE	EPDM	324757-01	1	1	1	1	1					
41	DRAIN	AC	309246-01	1	1	1	1	1					
42	"O" RING	1AP15	7611-P015	1	1	1	1	1					
43	FLOAT SWITCH STOP	SS	4A0137-01	1	1	1	1	1					
44	DISTRIBUTOR (C)	ABS	439238-01	1	1	1	1	1					
45	JOINT HOSE	EPDM	439296-01	1	1	1	1	1					
46	DISTRIBUTOR (B)	ABS	439239-01	1	1	1	1	1					
47	FLANGE	EPDM	439267-02	1	1	1	1	1					
48	BYPASS HOSE	SANTOPRENE	439237-02	1	1	1	1	1					
49	MALE ADAPTOR	ABS	325826-01	2	2	2	2	2					
50	"O" RING	1AP18	7611-P018	2	2	2	2	2					
51	BALL VALVE	PVC	439293-01	1	1	1	1	1					
52	VINYL HOSE	L=140	7716-0913	1	1	1	1	x1					
	SILICONE HOSE	L=140	7730I3812					o1					

MODEL: KM-1600SWE3 TITLE: C. WATER CIRCUIT													
INDEX NO.	DESCRIPTION	MATERIAL OR MODEL	PART NUMBER	REQUIRED NUMBER									
				D-0	E-0	F-1	G-1	H-0					
53	VINYL HOSE	L=390	7716-0913	1	1	1	1	x1					
	SILICONE HOSE	L=390	7730I3812					o1					
54	INSULATION HOSE	L=120	7762-3555	1	1	1	1	1					
55	INSULATION HOSE	L=80	7962-3555	1	1	1	1	1					
56	INSULATION HOSE	L=150	7962-3555	1	1	1	1	1					
57	VINYL HOSE	L=170	7716-2732	1	1	1	1	1					
58	VINYL HOSE	L=230	7716-2732	1	1	1	1	1					

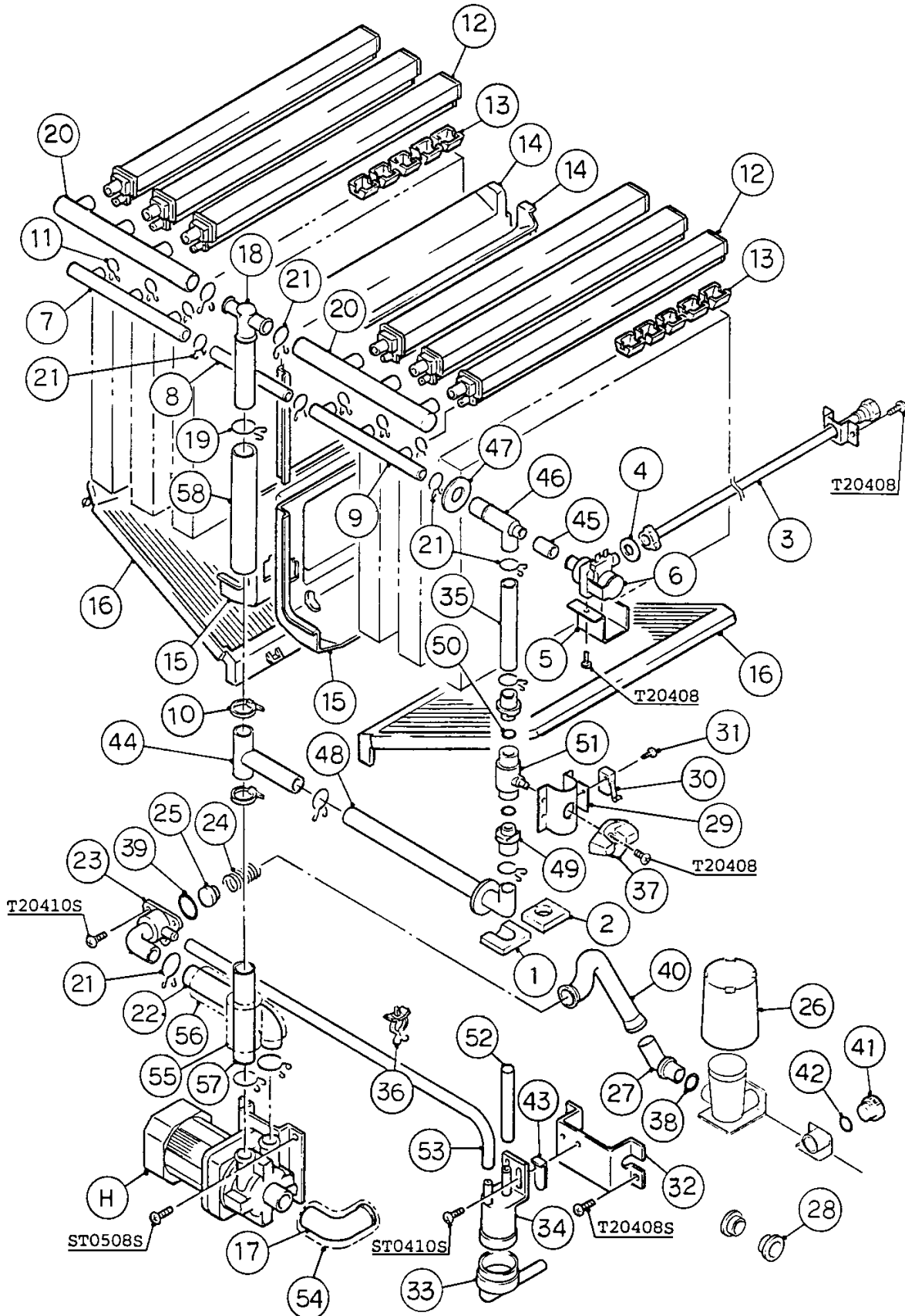

HA

KM-1600SRE, SRE3

C. WATER CIRCUIT

E-1, F-0, F-1, G-0, G-1, G-2, H-0, H-1

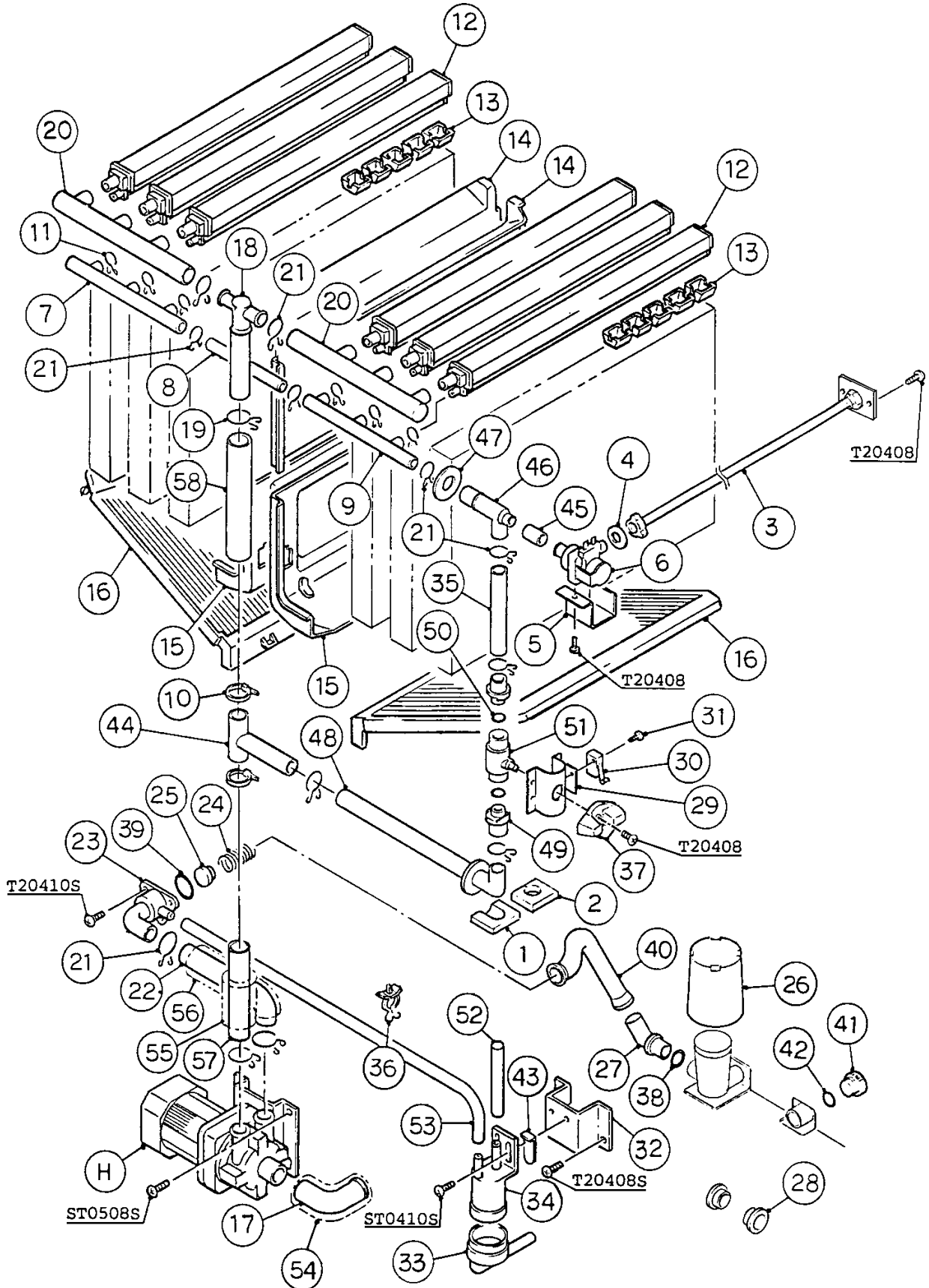

MODEL: KM-1600SRE, SRE3 TITLE: C. WATER CIRCUIT													
INDEX NO.	DESCRIPTION	MATERIAL OR MODEL	PART NUMBER	REQUIRED NUMBER									
				D-0	E-0	E-1	F-0	F-1	G-0	G-1	G-2	H-0	H-1
H	PUMP MOTOR ASSEMBLY	(S-0730)	215692A01	1	1	1	1	1	1	1	1	1	1
1	CORNER INSULATION (A)	PE FOAM	439376-01	1	1	1	1	1	1	1	1	1	1
2	CORNER INSULATION (B)	PE FOAM	439392-01	1	1	1	1	1	1	1	1	1	1
3	WATER SUPPLY PIPE	COPPER	4A0207G01	1	1	-							
		COPPER	4A0768G01			1	1	1	1	1	1	1	1
4	RUBBER GASKET	NR	413854-01	1	1	x1							
		SI. R	413854-03			o1	1	1	1	1	1	1	1
5	WATER VALVE BRACKET	GS	321443-01	1	1	1	1	1	1	1	1	1	1
6	WATER VALVE	J248-030	3U0111-01	1	1	1	1	1	1	1	1	1	1
7	DISTRIBUTOR HOSE (A)	EPDM	325738-01	1	1	1	1	1	1	1	1	1	1
8	JOINT PIPE	ABS	439297-01	1	1	1	1	1	1	1	1	1	1
9	DISTRIBUTOR HOSE (B)	EPDM	325738-02	1	1	1	1	1	1	1	1	1	1
10	CABLE TIE	CV-200	7920-0010	3	3	3	3	3	3	3	3	3	3
11	HOSE CLAMP	SS, 13.5 mm.	427443-07	6	6	6	6	6	6	6	6	6	6
12	SPRAY TUBE	ABS	437049G01	6	6	6	6	6	6	6	6	6	6
13	SPRAY GUIDE (A)	PE	208586-01	18	18	18	18	18	18	18	18	18	18
14	SEPARATOR (A)	ABS	213622-01	2	2	2	2	2	2	2	2	2	2
15	SEPARATOR (B)	ABS	2A0100-01	2	2	2	2	2	2	2	2	2	2
16	CUBE GUIDE	ABS	214243-01	2	2	2	2	2	2	2	2	2	2
17	HOSE (A)	EPDM	435091-01	1	1	1	1	1	1	1	1	1	1
18	DISTRIBUTOR	ABS	438276G01	1	1	1	1	1	1	1	1	1	1
19	HOSE CLAMP	SS, 32 mm.	427443-09	2	2	2	2	2	2	2	2	2	2
20	DISTRIBUTOR HOSE (C)	EPDM	323985-01	2	2	2	2	2	2	2	2	2	2
21	HOSE CLAMP	SS, 25 mm.	427443-03	11	11	11	11	11	11	11	11	11	11
22	HOSE (B)	EPDM	436599-01	1	1	1	1	1	1	1	1	1	1
23	VALVE HOUSING - DRAIN	ABS	323613-01	1	1	1	1	1	1	1	1	1	1
24	SPRING	SS	322685-01	1	1	1	1	x1					
		SS	322110-01					o1	1	1	1	1	1
25	VALVE SHEET	EPDM	433705-01	1	1	1	1	1	1	1	1	1	1
26	OVERFLOW CAP	PE	323978-01	1	1	1	1	1	1	1	1	1	1

MODEL: KM-1600SRE, SRE3 TITLE: C. WATER CIRCUIT													
INDEX NO.	DESCRIPTION	MATERIAL OR MODEL	PART NUMBER	REQUIRED NUMBER									
				D-0	E-0	E-1	F-0	F-1	G-0	G-1	G-2	H-0	H-1
27	JOINT - OVERFLOW	ABS	323923-02	1	1	1	1	1	1	1	1	1	1
28	BUSHING	SB-1093-15	420470-03	2	2	2	2	2	2	2	2	x2	
		-	420470-06									o2	2
29	VALVE HOLDER	GS	325825-01	1	1	1	1	1	1	1	1	1	1
30	MICRO SWITCH	V3L-111-08	4A0365-01	1	1	1	1	1	1	1	1	1	1
31	TAPPING SCREW	3 x 14	431415-02	2	2	2	2	2	2	2	2	2	2
32	FLOAT SWITCH BRACKET	SS	323906-01	1	1	-							
		SS	3A0449-01			1	1	1	1	1	1	1	1
33	CONNECTOR - FLOAT SWITCH	EPDM	426799-04	1	1	1	1	1	1	1	1	1	1
34	FLOAT SWITCH	FS-0893B-1	433535-02	1	1	1	x1						
		163795	4A0886-01				o1	1	1	1	1	1	1
35	JOINT HOSE	EPDM	439309-02	1	1	1	1	1	1	1	1	1	1
36	CLAMP	No. 4253	427902-05	1	1	1	1	1	1	1	1	1	1
37	HANDLE	JH1352	215383-01	1	1	1	1	1	1	1	1	1	1
38	"O" RING	1AP18	7611-P018	1	1	1	1	1	1	1	1	1	1
39	"O" RING	1AG35	7611-G035	1	1	1	1	1	1	1	1	1	1
40	DRAIN HOSE	EPDM	324757-01	1	1	1	1	1	1	1	1	1	1
41	DRAIN	AC	309246-01	1	1	1	1	1	1	1	1	1	1
42	"O" RING	1AP15	7611-P015	1	1	1	1	1	1	1	1	1	1
43	FLOAT SWITCH STOP	SS	4A0137-01	1	1	1	1	1	1	1	1	1	1
44	DISTRIBUTOR (C)	ABS	439238-01	1	1	1	1	1	1	1	1	1	1
45	JOINT HOSE	EPDM	439296-01	1	1	1	1	1	1	1	1	1	1
46	DISTRIBUTOR (B)	ABS	439239-01	1	1	1	1	1	1	1	1	1	1
47	FLANGE	EPDM	439267-02	1	1	1	1	1	1	1	1	1	1
48	BYPASS HOSE	SANTOPRENE	439237-02	1	1	1	1	1	1	1	1	1	1
49	MALE ADAPTOR	ABS	325826-01	2	2	2	2	2	2	2	2	2	2
50	"O" RING	1AP18	7611-P018	2	2	2	2	2	2	2	2	2	2
51	BALL VALVE	PVC	439293-01	1	1	1	1	1	1	1	1	1	1

MODEL: **KM-1600SRE, SRE3** TITLE: **C. WATER CIRCUIT**

INDEX NO.	DESCRIPTION	MATERIAL OR MODEL	PART NUMBER	REQUIRED NUMBER									
				D-0	E-0	E-1	F-0	F-1	G-0	G-1	G-2	H-0	H-1
52	VINYL HOSE	L=140	7716-0913	1	1	1	1	1	1	1	1	x1	
	SILICONE HOSE	L=140	7730I3812									o1	x1
			L=140	7730I3896									o1
53	VINYL HOSE	L=390	7716-0913	1	1	1	1	1	1	1	1	x1	
	SILICONE HOSE	L=390	7730I3812									o1	1
54	INSULATION HOSE	L=120	7762-3555	1	1	1	1	1	1	1	1	1	1
55	INSULATION HOSE	L=80	7962-3555	1	1	1	1	1	1	1	1	1	1
56	INSULATION HOSE	L=150	7962-3555	1	1	1	1	1	1	1	1	1	1
57	VINYL HOSE	L=170	7716-2732	1	1	1	1	1	1	1	1	1	1
58	VINYL HOSE	L=230	7716-2732	1	1	1	1	1	1	1	1	1	1

HA

KM-1600SWE, SWE3, SRE3

D. CONTROL BOX ASSEMBLY

D-0, E-0, E-1, F-0,

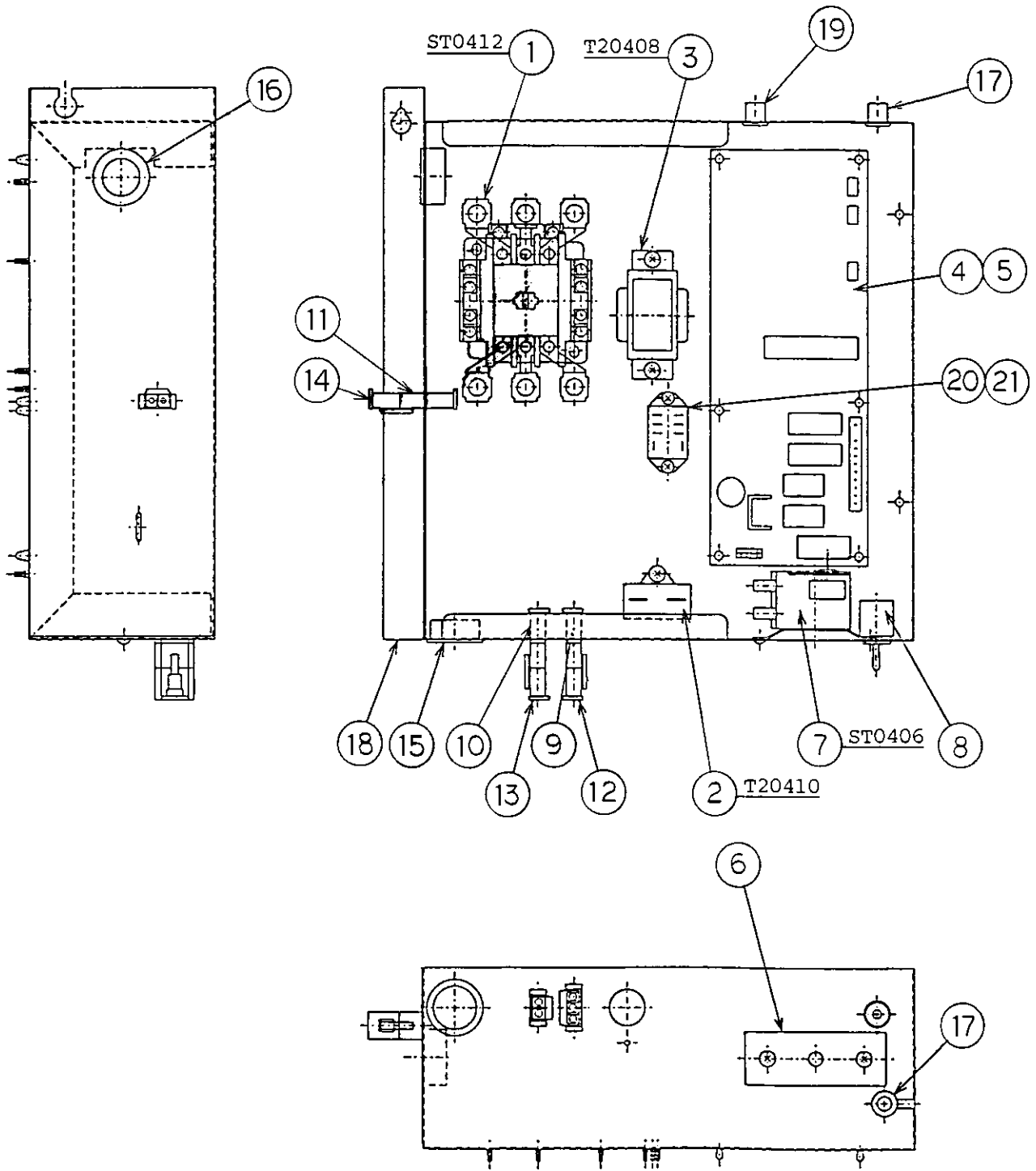

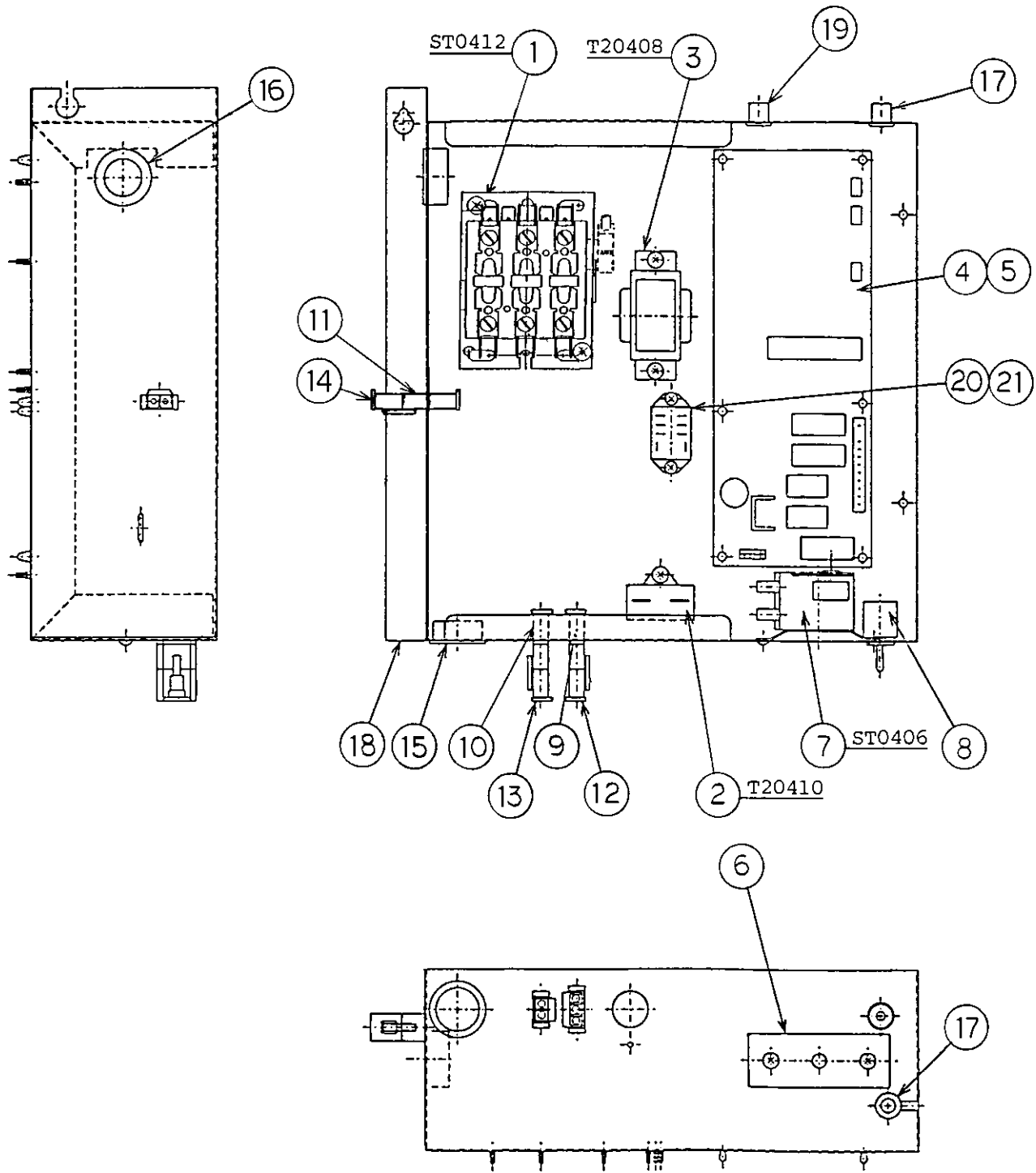

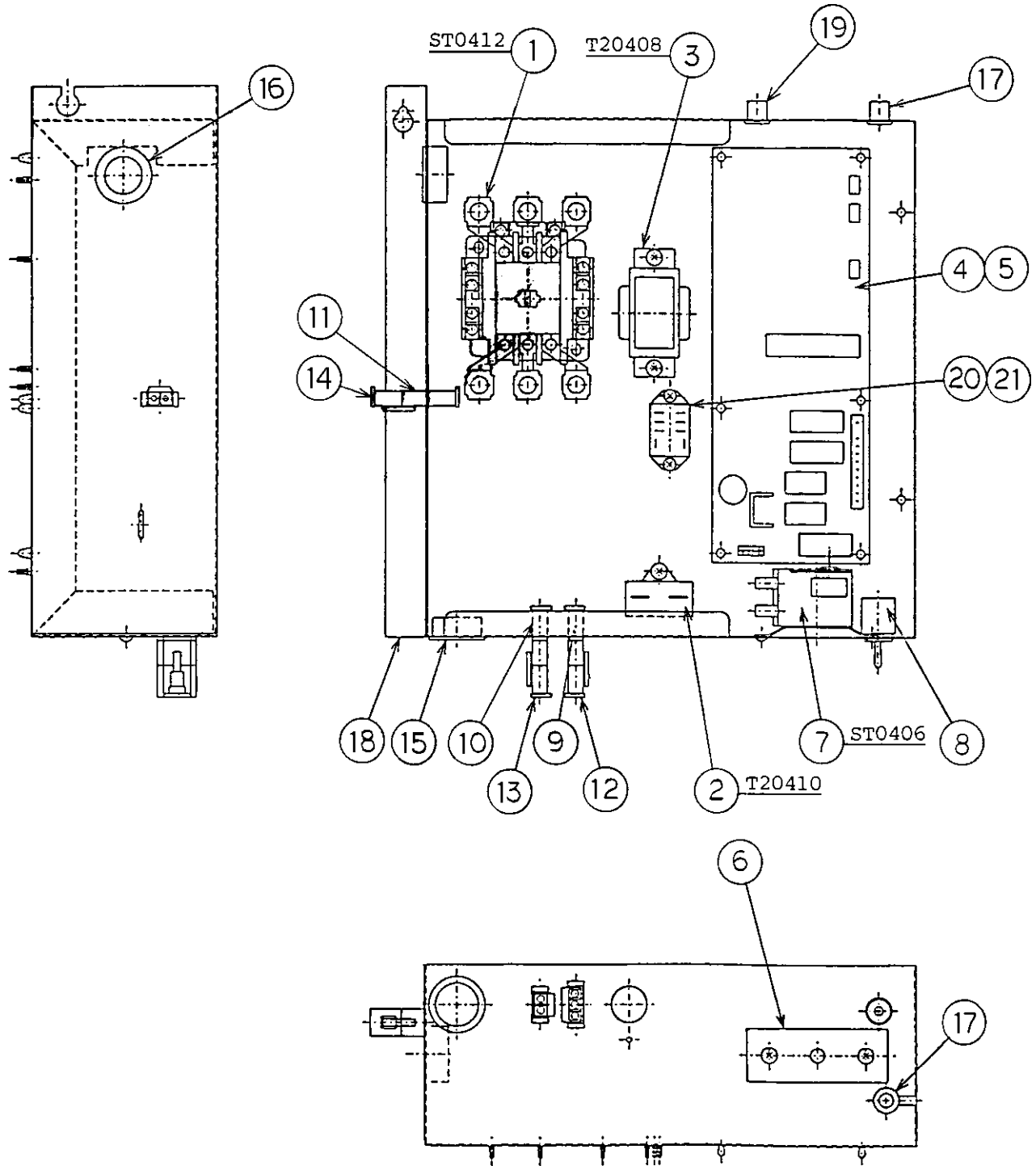

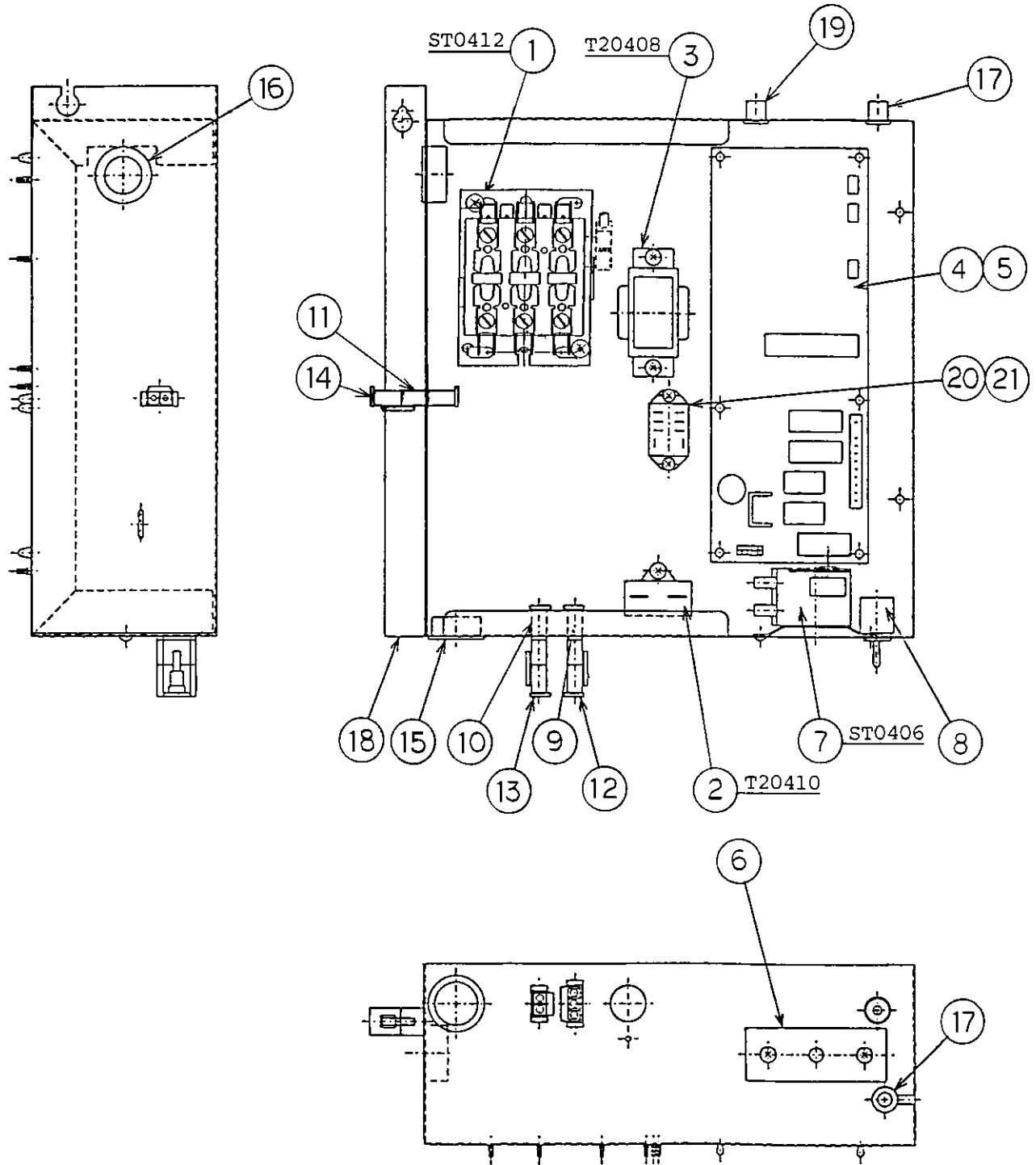

MODEL: KM-1600SWE TITLE: D. CONTROL BOX ASSEMBLY													
INDEX NO.	DESCRIPTION	MATERIAL OR MODEL	PART NUMBER	REQUIRED NUMBER									
				D-0	E-0	E-1	F-0	F-1	G-0	H-0			
1	MAGNETIC CONTACTOR	C-25E	438215-01	1	1	1	1	-					
		A77-309040A-226	4A0794-01					1	1	1			
2	CAPACITOR	250V, 10MFD	443192-01	1	1	1	1	1	1	1			
3	TRANSFORMER	26D285H	3A0172-01	1	1	1	1	1	1	1			
4	CONTROLLER BOARD	MY9KM910	2U0127-01	1	1	1	1	1	1	1			
5	BOARD SUPPORT	CBLS37-M	4A0336-03	6	6	6	6	6	6	6			
6	CONTROL LABEL	PES FILM	434934-01	1	1	1	1	1	1	1			
7	THERMOSTAT	A30-3842-00	439678-02	1	x1								
		A30-3842-00	4A0738-02		o1	1	x1						
		A30-3842-00	4A0824-02				o1	1	1	1			
8	TOGGLE SWITCH	8966K84	443119-01	1	1	1	1	1	1	1			
9	3P PLUG HOUSING	3191-03P	412832-06	1	1	1	1	1	1	1			
10	2P PLUG HOUSING	3191-02P	412832-07	1	1	1	1	1	1	1			
11	2P PLUG HOUSING	3190-02P (RED)	412832-09	1	1	1	1	1	1	1			
12	3P RECEPTACLE HOUSING	3191-03R1	412831-06	1	1	1	1	1	1	1			
13	2P RECEPTACLE HOUSING	3191-02R1	412831-07	1	1	1	1	1	1	1			
14	2P RECEPTACLE HOUSING	3191-02R1 (RED)	412831-09	1	1	1	1	1	1	1			
15	BUSHING	SB-1093-15	420470-03	1	1	1	1	1	1	1			
16	BUSHING	SB-1093-13	420470-12	1	1	1	1	1	1	1			
17	BUSHING	OCB-500	428394-02	2	2	2	2	2	2	2			
18	CONTROL BOX	GS	2A0121G05	1	1	1	1	1	1	1			
19	BUSHING	OCB-875	428394-04	1	1	1	1	1	1	1			
20	RELAY	LY2F, AC120V	406132-07	1	1	1	1	1	1	1			
21	TAPPING SCREW	3 x 8 STEEL	431415-01	2	2	2	2	2	2	2			

MODEL: KM-1600SWE3 TITLE: D. CONTROL BOX ASSEMBLY													
INDEX NO.	DESCRIPTION	MATERIAL OR MODEL	PART NUMBER	REQUIRED NUMBER									
				D-0	E-0	F-1	G-1	H-0					
1	MAGNETIC CONTACTOR	C-25E	438215-01	1	1	1	-						
		A77-309040A-226	4A0794-01				1	1					
2	CAPACITOR	250V, 10MFD	443192-01	1	1	1	1	1					
3	TRANSFORMER	26D285H	3A0172-01	1	1	1	1	1					
4	CONTROLLER BOARD	MY9KM910	2U0127-01	1	1	1	1	1					
5	BOARD SUPPORT	CBLS37-M	4A0336-03	6	6	6	6	6					
6	CONTROL LABEL	PES FILM	434934-01	1	1	1	1	1					
7	THERMOSTAT	A30-3842-00	439678-02	1	x1								
		A30-3842-00	4A0738-02		o1	x1							
		A30-3842-00	4A0824-02			o1	1	1					
8	TOGGLE SWITCH	8966K84	443119-01	1	1	1	1	1					
9	3P PLUG HOUSING	3191-03P	412832-06	1	1	1	1	1					
10	2P PLUG HOUSING	3191-02P	412832-07	1	1	1	1	1					
11	2P PLUG HOUSING	3190-02P (RED)	412832-09	1	1	1	1	1					
12	3P RECEPTACLE HOUSING	3191-03R1	412831-06	1	1	1	1	1					
13	2P RECEPTACLE HOUSING	3191-02R1	412831-07	1	1	1	1	1					
14	2P RECEPTACLE HOUSING	3191-02R1 (RED)	412831-09	1	1	1	1	1					
15	BUSHING	SB-1093-15	420470-03	1	1	1	1	1					
16	BUSHING	SB-1093-13	420470-12	1	1	1	1	1					
17	BUSHING	OCB-500	428394-02	2	2	2	2	2					
18	CONTROL BOX	GS	2A0121G05	1	1	1	1	1					
19	BUSHING	OCB-875	428394-04	1	1	1	1	1					
20	RELAY	LY2F, AC120V	406132-07	1	1	1	1	1					
21	TAPPING SCREW	3 x 8 STEEL	431415-01	2	2	2	2	2					

MODEL: KM-1600SRE TITLE: D. CONTROL BOX ASSEMBLY													
INDEX NO.	DESCRIPTION	MATERIAL OR MODEL	PART NUMBER	REQUIRED NUMBER									
				D-0	E-0	E-1	F-0	F-1	G-0	G-1	G-2	H-0	H-1
1	MAGNETIC CONTACTOR	C-25E	438215-01	1	1	1	1	-					
		A77-309040A-226	4A0794-01					1	1	1	-		
		C-25E	438215-01								1	-	
		A77-309040A-226	4A0794-01									1	1
2	CAPACITOR	250V, 10MFD	443192-01	1	1	1	1	1	1	1	1	1	1
3	TRANSFORMER	26D285H	3A0172-01	1	1	1	1	1	1	1	1	1	1
4	CONTROLLER BOARD	MY9KM910	2U0127-01	1	1	1	1	1	1	1	1	1	1
5	BOARD SUPPORT	CBL537-M	4A0336-03	6	6	6	6	6	6	6	6	6	6
6	CONTROL LABEL	PES FILM	434934-01	1	1	1	1	1	1	1	1	1	1
7	THERMOSTAT	A30-3842-00	439678-02	1	x1								
		A30-3842-00	4A0738-02		o1	1	x1						
		A30-3842-00	4A0824-02				o1	1	1	1	1	1	1
8	TOGGLE SWITCH	8966K84	443119-01	1	1	1	1	1	1	1	1	1	1
9	3P PLUG HOUSING	3191-03P	412832-06	1	1	1	1	1	1	1	1	1	1
10	2P PLUG HOUSING	3191-02P	412832-07	1	1	1	1	1	1	1	1	1	1
11	2P PLUG HOUSING	3190-02P (RED)	412832-09	1	1	1	1	1	1	1	1	1	1
12	3P RECEPTACLE HOUSING	3191-03R1	412831-06	1	1	1	1	1	1	1	1	1	1
13	2P RECEPTACLE HOUSING	3191-02R1	412831-07	1	1	1	1	1	1	1	1	1	1
14	2P RECEPTACLE HOUSING	3191-02R1 (RED)	412831-09	1	1	1	1	1	1	1	1	1	1
15	BUSHING	SB-1093-15	420470-03	1	1	1	1	1	1	1	1	1	1
16	BUSHING	SB-1093-13	420470-12	1	1	1	1	1	1	1	1	1	1
17	BUSHING	OCB-500	428394-02	2	2	2	2	2	2	2	2	2	2
18	CONTROL BOX	GS	2A0121G05	1	1	1	1	1	1	1	1	1	1
19	BUSHING	OCB-875	428394-04	1	1	1	1	1	1	1	1	1	1
20	RELAY	LY2F, AC120V	406132-07	1	1	1	1	1	1	1	1	1	1
21	TAPPING SCREW	3 x 8 STEEL	431415-01	2	2	2	2	2	2	2	2	2	2

MODEL: KM-1600SRE3 TITLE: D. CONTROL BOX ASSEMBLY													
INDEX NO.	DESCRIPTION	MATERIAL OR MODEL	PART NUMBER	REQUIRED NUMBER									
				D-0	E-0	E-1	F-0	F-1	G-0	G-1	H-0		
1	MAGNETIC CONTACTOR	C-25E	438215-01	1	1	1	1	-					
		A77-309040A-226	4A0794-01					1	1	1	1		
2	CAPACITOR	250V, 10MFD	443192-01	1	1	1	1	1	1	1	1	1	
3	TRANSFORMER	26D285H	3A0172-01	1	1	1	1	1	1	1	1	1	
4	CONTROLLER BOARD	MY9KM910	2U0127-01	1	1	1	1	1	1	1	1	1	
5	BOARD SUPPORT	CBLS37-M	4A0336-03	6	6	6	6	6	6	6	6	6	
6	CONTROL LABEL	PES FILM	434934-01	1	1	1	1	1	1	1	1	1	
7	THERMOSTAT	A30-3842-00	439678-02	1	x1								
		A30-3842-00	4A0738-02		o1	1	x1						
		A30-3842-00	4A0824-02				o1	1	1	1	1		
8	TOGGLE SWITCH	8966K84	443119-01	1	1	1	1	1	1	1	1	1	
9	3P PLUG HOUSING	3191-03P	412832-06	1	1	1	1	1	1	1	1	1	
10	2P PLUG HOUSING	3191-02P	412832-07	1	1	1	1	1	1	1	1	1	
11	2P PLUG HOUSING	3190-02P (RED)	412832-09	1	1	1	1	1	1	1	1	1	
12	3P RECEPTACLE HOUSING	3191-03R1	412831-06	1	1	1	1	1	1	1	1	1	
13	2P RECEPTACLE HOUSING	3191-02R1	412831-07	1	1	1	1	1	1	1	1	1	
14	2P RECEPTACLE HOUSING	3191-02R1 (RED)	412831-09	1	1	1	1	1	1	1	1	1	
15	BUSHING	SB-1093-15	420470-03	1	1	1	1	1	1	1	1	1	
16	BUSHING	SB-1093-13	420470-12	1	1	1	1	1	1	1	1	1	
17	BUSHING	OCB-500	428394-02	2	2	2	2	2	2	2	2	2	
18	CONTROL BOX	GS	2A0121G05	1	1	1	1	1	1	1	1	1	
19	BUSHING	OCB-875	428394-04	1	1	1	1	1	1	1	1	1	
20	RELAY	LY2F, AC120V	406132-07	1	1	1	1	1	1	1	1	1	
21	TAPPING SCREW	3 x 8 STEEL	431415-01	2	2	2	2	2	2	2	2	2	

HA

KM-1600SWE, SWE3

E. LABEL LOCATION

D-0, E-0, E-1, F-0, F-1, G-0, G-1

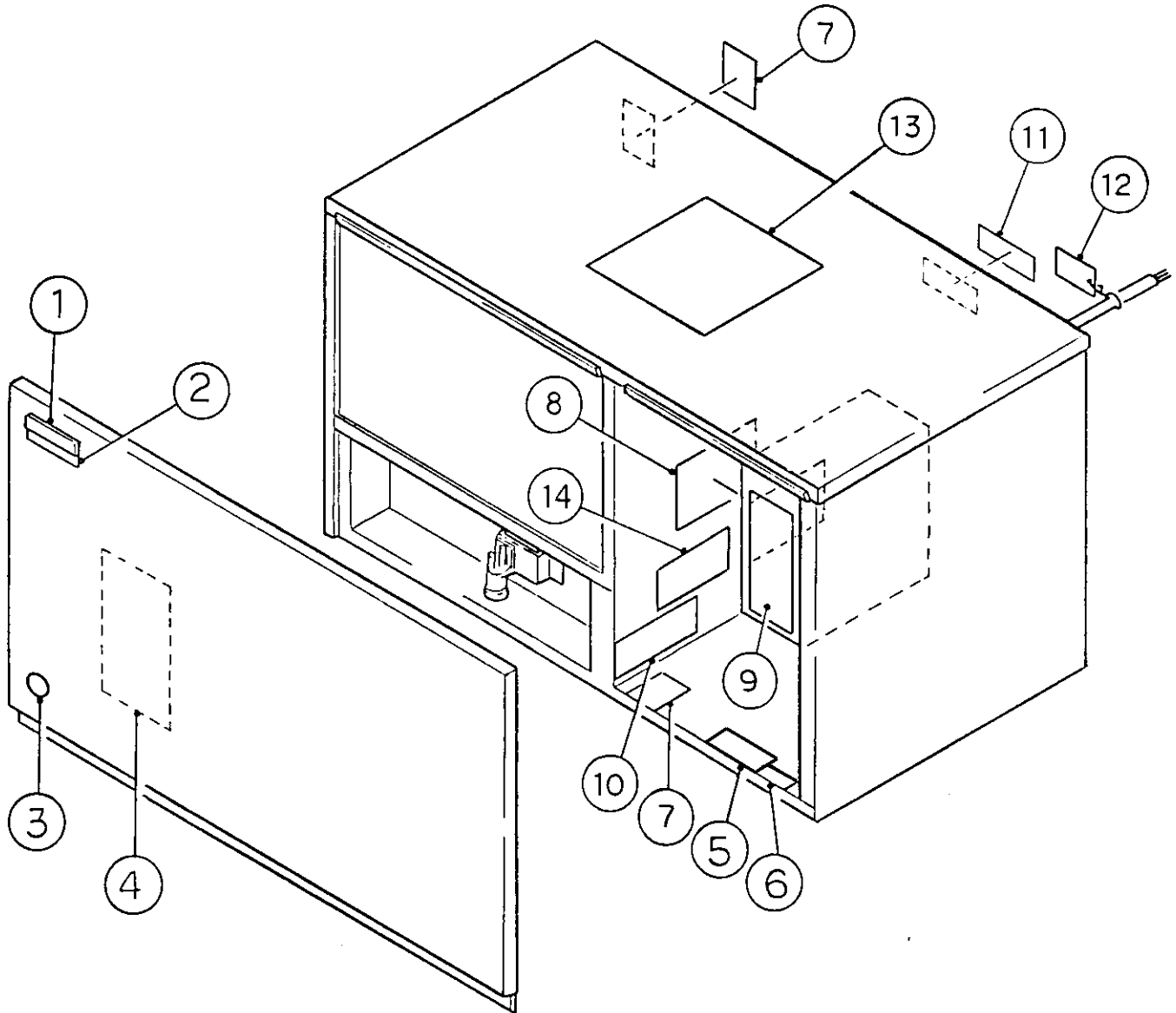

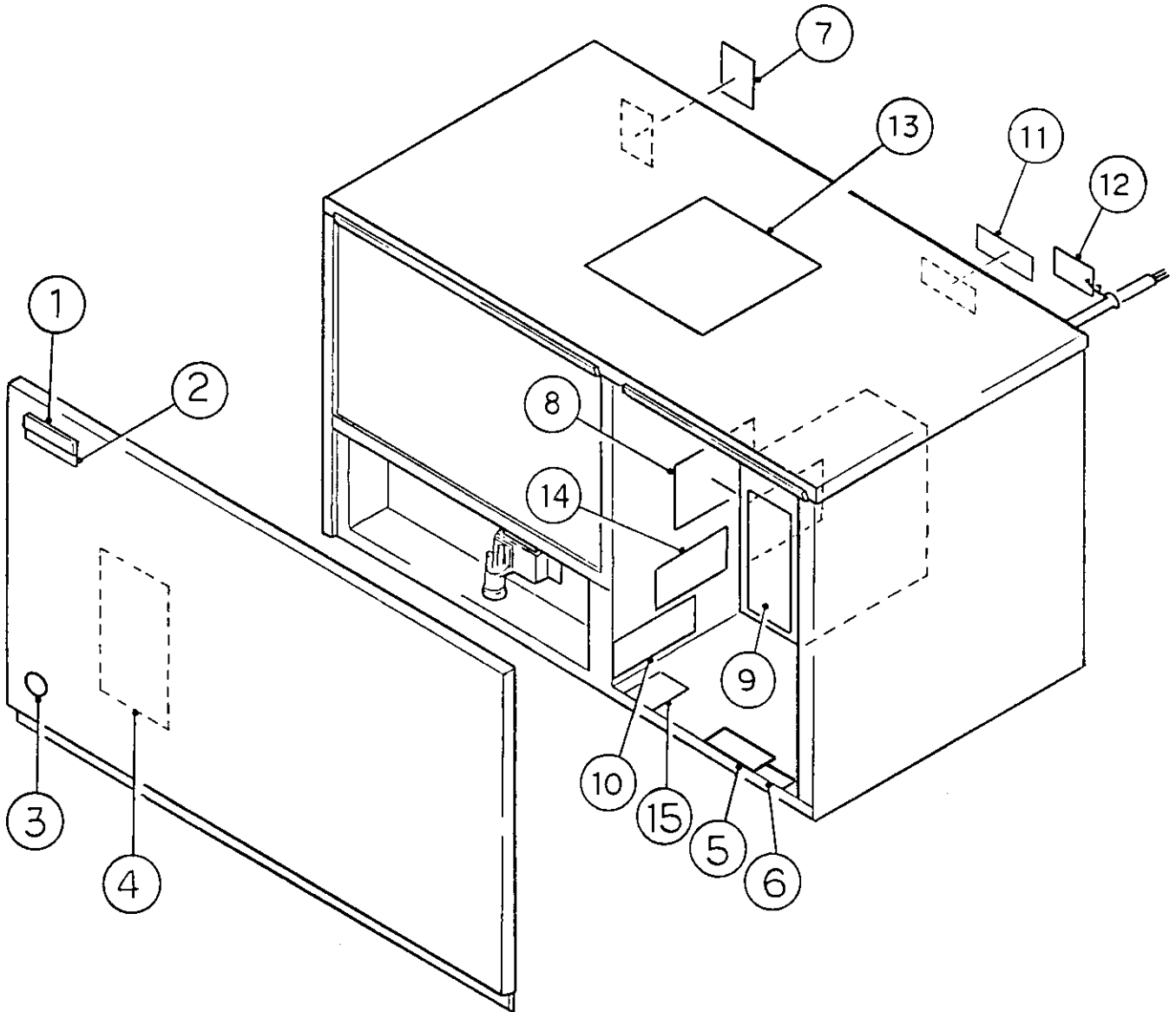

MODEL: KM-160SWE TITLE: E. LABEL LOCATION													
INDEX NO.	DESCRIPTION	MATERIAL OR MODEL	PART NUMBER	REQUIRED NUMBER									
				D-0	E-0	E-1	F-0	F-1	G-0	H-0			
1	EMBLEM (L) HOSHIZAKI	ABS	418634G01	1	1	1	1	x1					
	EMBLEM	ABS	4A0560-01					o1	1	1			
2	MODEL NUMBER LABEL	PETP FILM	443341-15	1	1	1	1	1	1	1			
3	LABEL - PENGUIN (R)	PETP FILM	410994-01	1	1	1	x1						
		PETP FILM	4A0526-01				o1	1	1	1			
4	MAINTENANCE LABEL	PVC FILM	326275-01	1	1	1	1	1	1	1			
5	WARNING LABEL - DANGER	PVC FILM	425322-01	1	1	1	1	1	1	1	x1		
	CAUTION LABEL (K)	-	439150-01								o1		
6	LABEL - R22	PES FILM	440362-01	1	1	1	1	1	1	1	1		
7	NAMEPLATE	PES FILM	445506-01	2	2	2	2	2	2	2	1		
8	WIRING LABEL	PVC FILM	331296-01	1	1	1	1	-					
		PVC FILM	3A0480-01					1	1	1			
9	MANUAL LABEL	PVC FILM	324476-01	1	1	1	1	1	1	1	1		
10	MANUAL LABEL - BIN CONTROL	PVC FILM	324477-01	1	1	1	1	1	1	1	1		
11	INSTRUCTION LABEL	PVC FILM	444575-01	1	1	1	1	1	1	1	1		
12	TAG - WARNING: ELECTRICAL CONNECTION	PAPER	428430-01	1	1	1	1	1	1	1	1		
13	INSTRUCTION SHEET	PAPER	218058-01	1	1	1	1	1	1	1	1		
14	OPERATION LABEL - VALVE	PVC FILM	439541-01	1	1	1	1	1	1	1	1		
15	RATING LABEL	-	4A1623-01								1		

MODEL: KM-1600SWE3 TITLE: E. LABEL LOCATION													
INDEX NO.	DESCRIPTION	MATERIAL OR MODEL	PART NUMBER	REQUIRED NUMBER									
				D-0	E-0	F-1	G-1	H-0					
1	EMBLEM (L) HOSHIZAKI	ABS	418634G01	1	1	x1							
	EMBLEM	ABS	4A0560-01			o1	1	1					
2	MODEL NUMBER LABEL	PETP FILM	443341-16	1	1	1	1	1					
3	LABEL - PENGUIN (R)	PETP FILM	410994-01	1	1	1	x1						
		PETP FILM	4A0526-01				o1	1					
4	MAINTENANCE LABEL	PVC FILM	326275-01	1	1	1	1	1					
5	WARNING LABEL - DANGER	PVC FILM	425322-01	1	1	1	1	x1					
	CAUTION LABEL (K)	-	439150-01					o1					
6	LABEL - R22	PES FILM	440362-01	1	1	1	1	1					
7	NAMEPLATE	PES FILM	445507-01	2	2	2	2	1					
8	WIRING LABEL	PVC FILM	331319-01	1	1	1	-						
		PVC FILM	3A0481-01				1	1					
9	MANUAL LABEL	PVC FILM	324476-01	1	1	1	1	1					
10	MANUAL LABEL - BIN CONTROL	PVC FILM	324477-01	1	1	1	1	1					
11	INSTRUCTION LABEL	PVC FILM	444575-01	1	1	1	1	1					
12	TAG - WARNING: ELECTRICAL CONNECTION	PAPER	438479-01	1	1	1	1	1					
13	INSTRUCTION SHEET	PAPER	218058-01	1	1	1	1	1					
14	OPERATION LABEL - VALVE	PVC FILM	439541-01	1	1	1	1	1					
15	RATING LABEL	-	4A1624-01					1					

HA

KM-1600SRE, SRE3

E. LABEL LOCATION

D-0, E-0, E-1, F-0, F-1, G-0, G-1, G-2

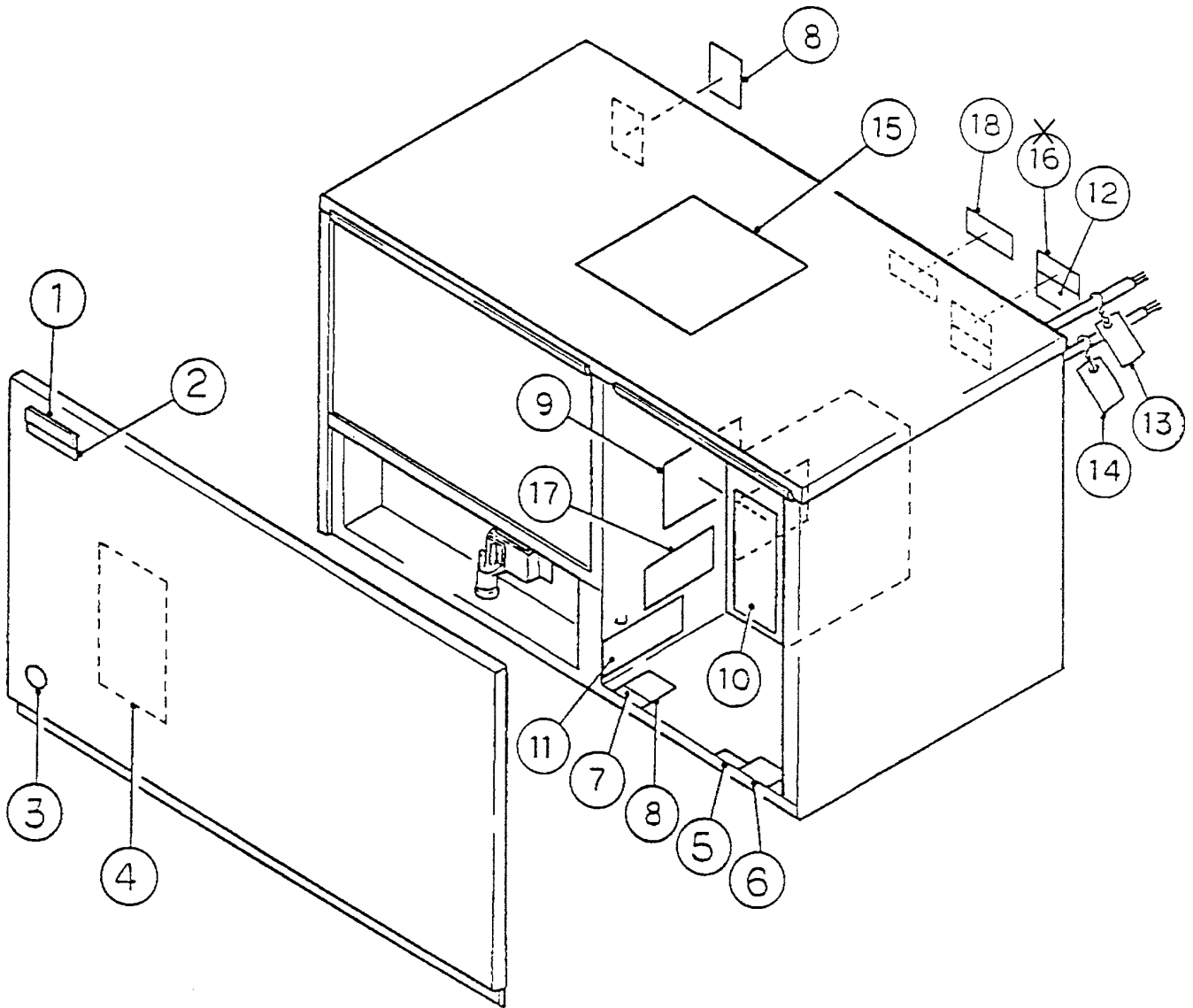

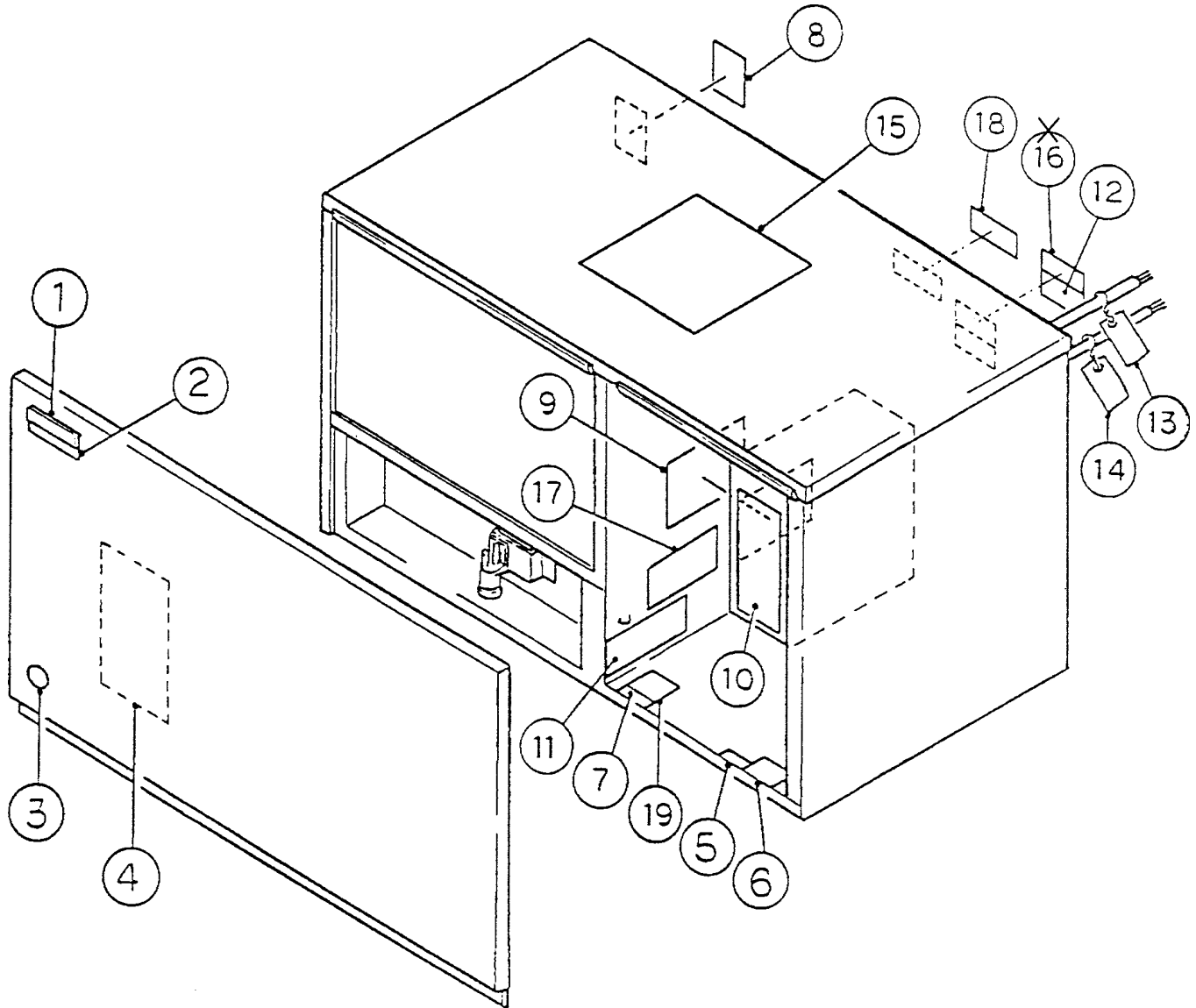

MODEL: KM-1600SRE TITLE: E. LABEL LOCATION													
INDEX NO.	DESCRIPTION	MATERIAL OR MODEL	PART NUMBER	REQUIRED NUMBER									
				D-0	E-0	E-1	F-0	F-1	G-0	G-1	G-2	H-0	H-1
1	EMBLEM (L) HOSHIZAKI	ABS	418634G01	1	1	1	1	x1					
	EMBLEM	ABS	4A0560-01					o1	1	1	1	1	1
2	MODEL NUMBER LABEL	PETP FILM	443341-17	1	1	1	1	1	1	1	1	1	1
3	LABEL - PENGUIN (R)	PETP FILM	410994-01	1	1	1	x1						
		PETP FILM	4A0526-01				o1	1	1	1	1	1	1
4	MAINTENANCE LABEL	PVC FILM	326275-01	1	1	1	1	1	1	1	1	1	1
5	WARNING LABEL - DANGER	PVC FILM	425322-01	1	1	1	1	1	1	1	1	x1	
	CAUTION LABEL (K)	-	439150-01									o1	1
6	LABEL - R22	PES FILM	440362-01	1	1	1	1	1	1	1	1	1	1
7	LABEL - CHARGE	PES FILM	443221-06	1	1	1	1	1	1	1	1	1	1
8	NAMEPLATE	PES FILM	445504-01	2	2	2	2	2	2	2	2	1	1
9	WIRING LABEL	PVC FILM	331184-01	1	1	1	1	-					
		PVC FILM	3A0478-01					1	1	1	-		
		PVC FILM	331184-01								1	-	
		PVC FILM	3A0478-01									1	1
10	MANUAL LABEL	PVC FILM	324476-01	1	1	1	1	1	1	1	1	1	1
11	MANUAL LABEL - BIN CONTROL	PVC FILM	324477-01	1	1	1	1	1	1	1	1	1	1
12	CAUTION LABEL	PVC FILM	441890-01	1	1	1	1	1	1	1	1	x1	
	CAUTION – REMOTE LABEL	-	4A1491-01									o1	1
13	TAG - WARNING: ELECTRICAL CONNECTION	PAPER	428430-01	1	1	1	1	1	1	1	1	1	1
14	TAG - FAN MOTOR LEADS	PAPER	420742-01	x1									
		PAPER	4A0647-01	o1	1	1	1	1	1	1	1	1	1
15	INSTRUCTION SHEET	PAPER	218058-01	1	1	1	1	1	1	1	1	1	1
16	LABEL - CONNECTION	PVC FILM	438234-01	-									
17	OPERATION LABEL - VALVE	PVC FILM	439541-01	1	1	1	1	1	1	1	1	1	1
18	INSTRUCTION LABEL	PVC FILM	444575-01	1	1	1	1	1	1	1	1	1	1
19	RATING LABEL	-	4A1625-01									1	1

MODEL: KM-1600SRE3 TITLE: E. LABEL LOCATION													
INDEX NO.	DESCRIPTION	MATERIAL OR MODEL	PART NUMBER	REQUIRED NUMBER									
				D-0	E-0	E-1	F-0	F-1	G-0	G-1	H-0		
1	EMBLEM (L) HOSHIZAKI	ABS	418634G01	1	1	1	1	x1					
	EMBLEM	ABS	4A0560-01					o1	1	1	1		
2	MODEL NUMBER LABEL	PETP FILM	443341-18	1	1	1	1	1	1	1	1		
3	LABEL - PENGUIN (R)	PETP FILM	410994-01	1	1	1	x1						
		PETP FILM	4A0526-01				o1	1	1	1	1		
4	MAINTENANCE LABEL	PVC FILM	326275-01	1	1	1	1	1	1	1	1		
5	WARNING LABEL - DANGER	PVC FILM	425322-01	1	1	1	1	1	1	1	1	x1	
	CAUTION LABEL (K)	-	439150-01									o1	
6	LABEL - R22	PES FILM	440362-01	1	1	1	1	1	1	1	1	1	
7	LABEL - CHARGE	PES FILM	443221-06	1	1	1	1	1	1	1	1	1	
8	NAMEPLATE	PES FILM	445505-01	2	2	2	2	2	2	2	2	1	
9	WIRING LABEL	PVC FILM	332663-01	1	1	1	1	-					
		PVC FILM	3A0479-01					1	1	1	1		
10	MANUAL LABEL	PVC FILM	324476-01	1	1	1	1	1	1	1	1	1	
11	MANUAL LABEL - BIN CONTROL	PVC FILM	324477-01	1	1	1	1	1	1	1	1	1	
12	CAUTION LABEL	PVC FILM	441890-01	1	1	1	1	1	1	1	1	x1	
	CAUTION – REMOTE LABEL	-	4A1491-01									o1	
13	TAG - WARNING: ELECTRICAL CONNECTION	PAPER	438479-01	1	1	1	1	1	1	1	1	1	
14	TAG - FAN MOTOR LEADS	PAPER	420742-01	x1									
		PAPER	4A0647-01	o1	1	1	1	1	1	1	1	1	
15	INSTRUCTION SHEET	PAPER	218058-01	1	1	1	1	1	1	1	1	1	
16	LABEL - CONNECTION	PVC FILM	438234-01	-									
17	OPERATION LABEL - VALVE	PVC FILM	439541-01	1	1	1	1	1	1	1	1	1	
18	INSTRUCTION LABEL	PVC FILM	444575-01	1	1	1	1	1	1	1	1	1	
19	RATING LABEL	-	4A1626-01									1	

HA

KM-1600SWE, SRE

F. CAPACITOR BOX ASSEMBLY

D-0, E-0, E-1, F-0,
F-1, G-0, G-1, G-2,
H-0, H-1

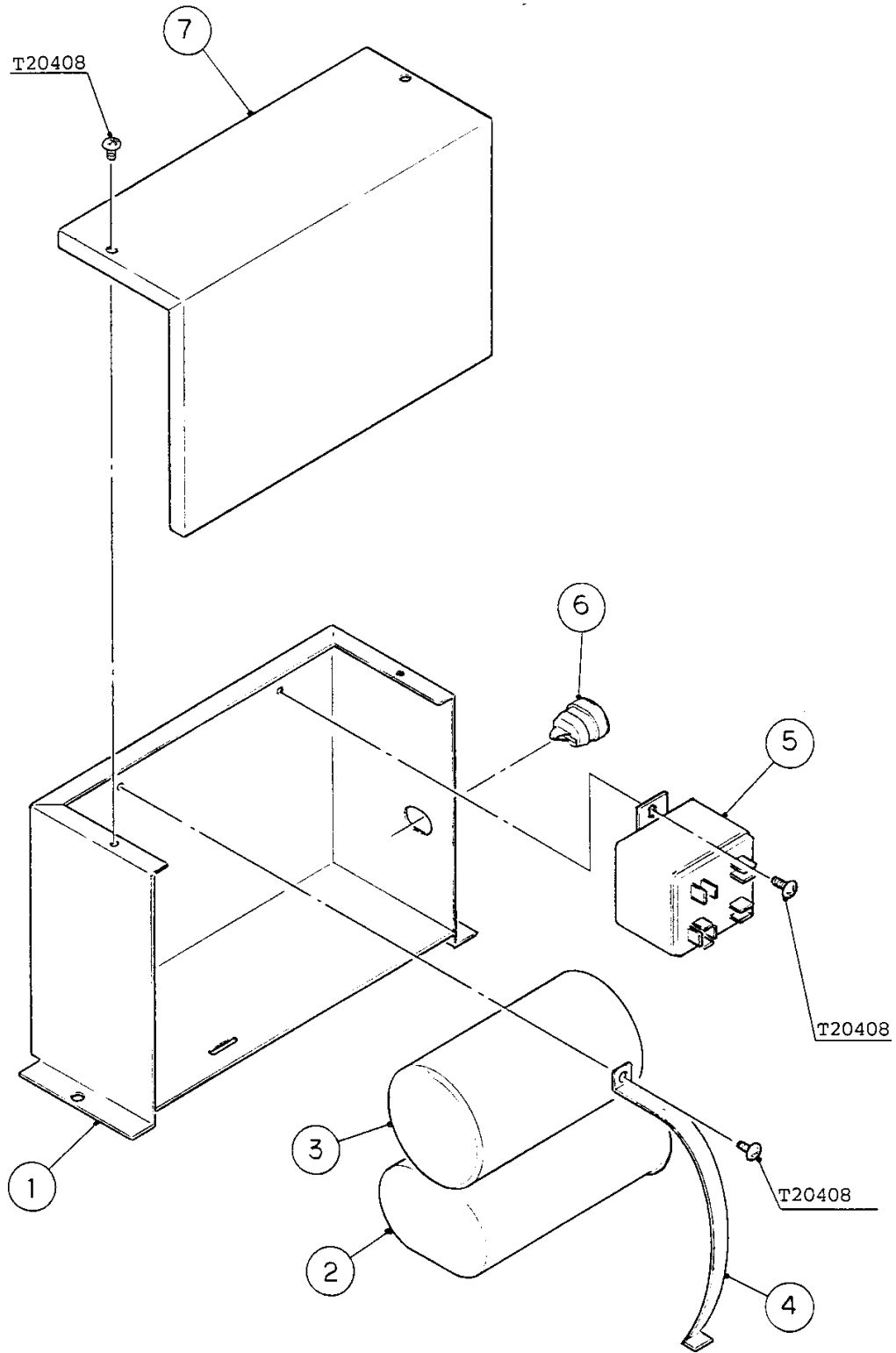

MODEL: KM-1600SWE, SRE TITLE: F. CAPACITOR BOX ASSEMBLY													
INDEX NO.	DESCRIPTION	MATERIAL OR MODEL	PART NUMBER	REQUIRED NUMBER									
				D-0	E-0	E-1	F-0	F-1	G-0	G-1	G-2	H-0	H-1
1	CAPACITOR BOX	GS	326124-02	1	1	1	1	1	1	1	1	1	1
2	CAPACITOR	40MFD, 440V	439943-03	1	1	1	1	1	1	1	1	1	1
3	CAPACITOR - STARTING	135-155MFD, 330V	3A0076-05	1	1	1	1	1	1	1	1	1	1
4	STRAP	GS	434580-08	1	1	1	1	1	1	1	1	1	1
5	STARTER	3ARR3T4A3	438207-01	1	1	1	1	1	1	1	1	1	1
6	BUSHING	SR-30-1	420472-03	1	1	1	1	1	1	1	1	1	1
7	CAPACITOR BOX COVER	GS	326125-01	1	1	1	1	1	1	1	1	1	1

HA

KM-1600SWE3, SRE3

F. TRANSFORMER BOX ASSEMBLY

D-0, E-0, E-1, F-0,
F-1, G-0, G-1, H-0

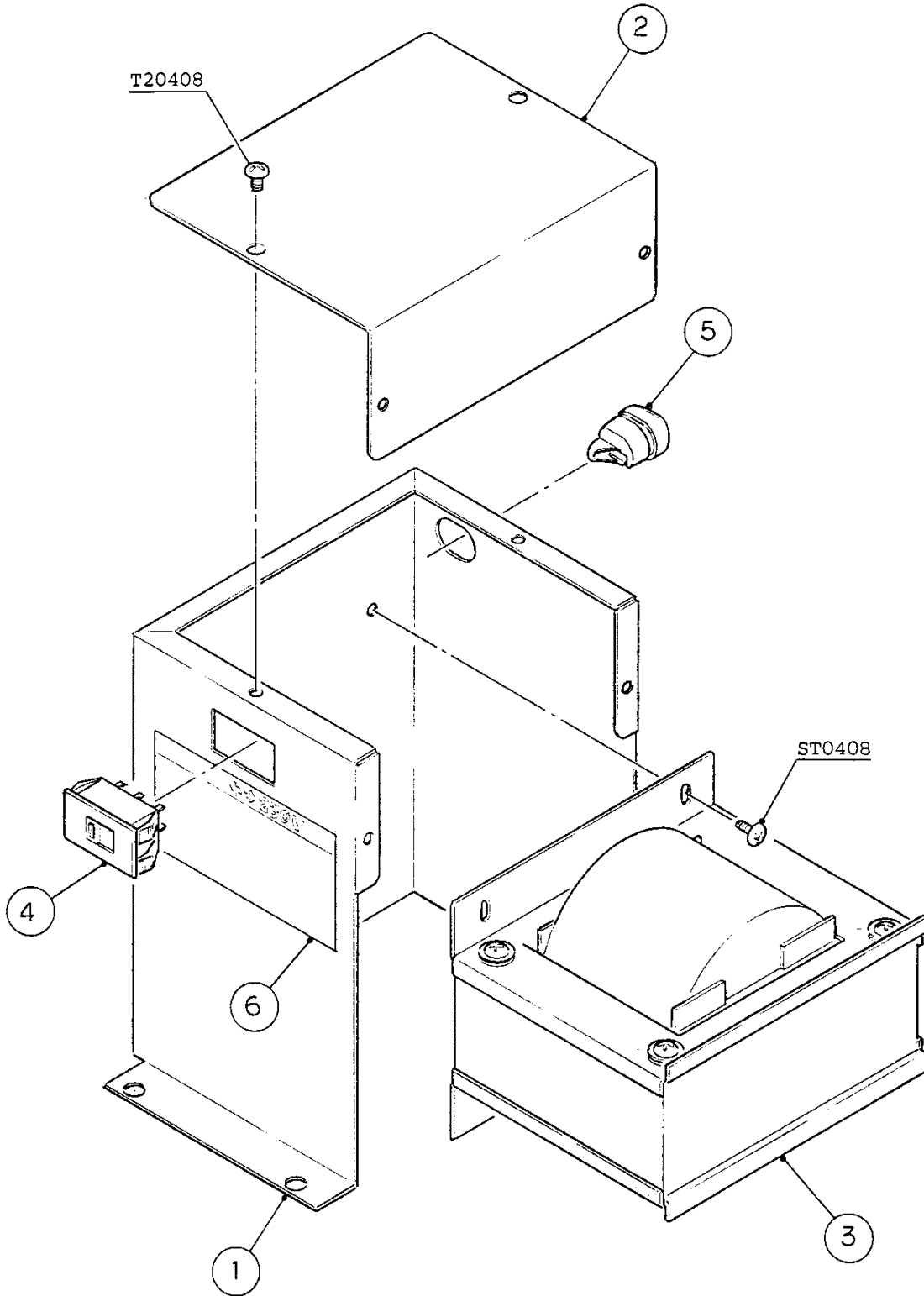

MODEL: KM-1600SWE3, SRE3 TITLE: F. TRANSFORMER BOX ASSEMBLY												
INDEX NO.	DESCRIPTION	MATERIAL OR MODEL	PART NUMBER	REQUIRED NUMBER								
				D-0	E-0	E-1	F-0	F-1	G-0	G-1	H-0	
1	TRANSFORMER BOX	-	333074-01	1	1	1	1	1	1	1	1	
2	TRANSFORMER BOX COVER	40MFD, 440V	438467-01	1	1	1	1	1	1	1	1	
3	TRANSFORMER	BE24543001	4A0374-01	1	1	1	1	1	1	1	1	
4	SLIDE SWITCH	SE1022-SD- PM-F-R-HK-A	439305-01	1	1	1	1	1	1	1	1	
5	BUSHING	SR-30-1	420472-03	1	1	1	1	1	1	1	1	
6	MANUAL LABEL - TAP SWITCH	PVC FILM	439423-01	1	1	1	1	1	1	1	1	

HA

KM-1600SWE, SWE3, SRE, SRE3

G. EVAPORATOR

D-0, E-0, E-1, F-0,
F-1, G-0, G-1, G-2,
H-0, H-1

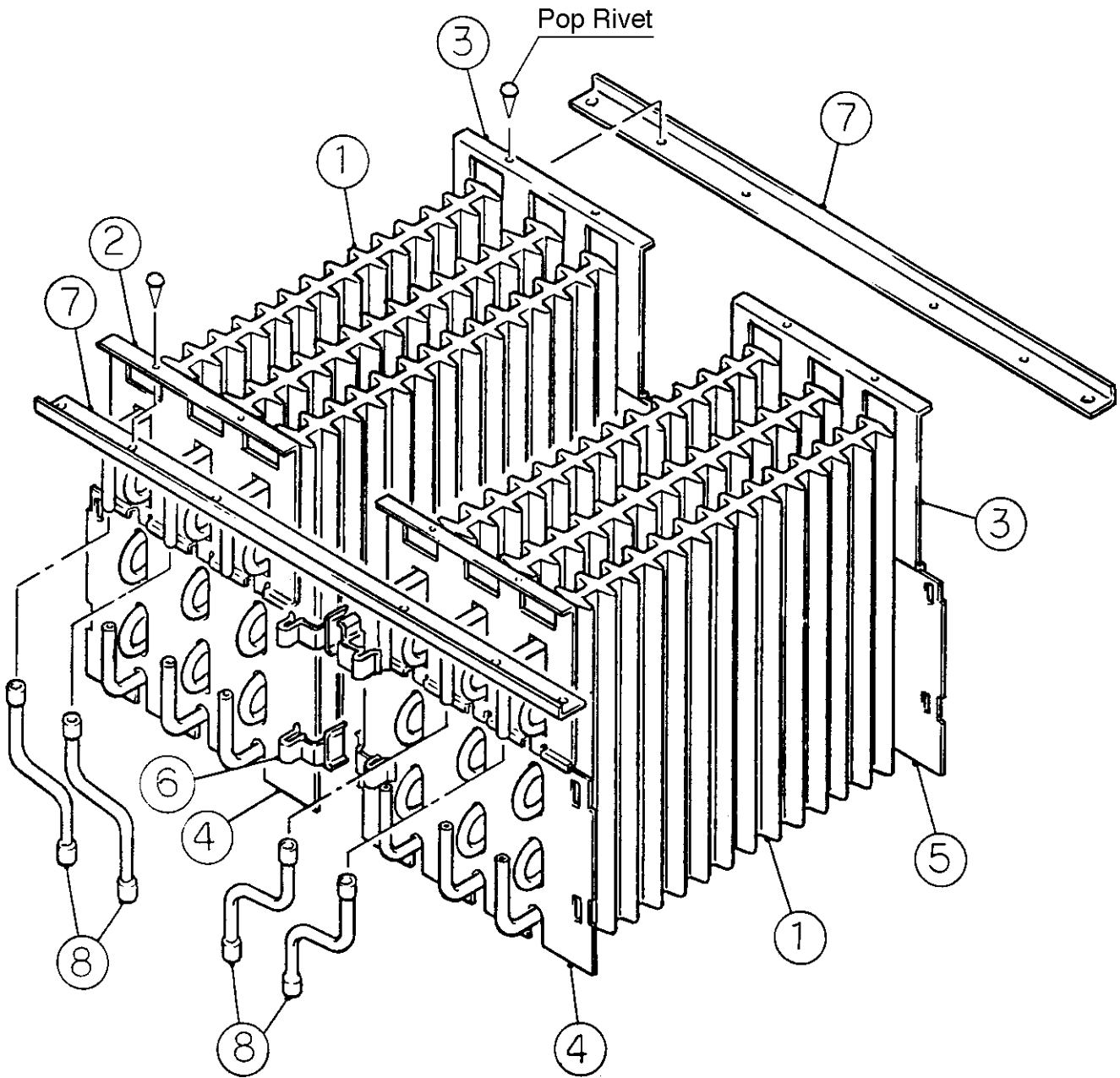

HA

MODEL: KM-1600SWE, SWE3, SRE, SRE3 TITLE: G. EVAPORATOR													
INDEX NO.	DESCRIPTION	MATERIAL OR MODEL	PART NUMBER	REQUIRED NUMBER									
				D-0	E-0	E-1	F-0	F-1	G-0	G-1	G-2	H-0	H-1
1	EVAPORATOR	(S-0533)	103444G02	6	6	6	6	6	6	6	6	6	6
2	EVAPORATOR BRACKET (A)	SS	323690-01	2	2	2	2	2	2	2	2	2	2
3	EVAPORATOR BRACKET (B)	SS	323691-01	2	2	2	2	2	2	2	2	2	2
4	END PLATE (A)	ABS	323692-01	2	2	2	2	2	2	2	2	2	2
5	END PLATE (B)	ABS	323693-01	2	2	2	2	2	2	2	2	2	2
6	HOOK	PE	324152-01	x8									
		PP	324152-01	o8	8	8	8	8	8	8	8	8	8
7	EVAPORATOR BRACKET	GS	436582-01	2	2	2	2	2	2	2	2	2	2
8	COPPER TUBE	COPPER	434137-01	4	4	4	4	4	4	4	4	4	4

HA

KM-1600SWE, SWE3, SRE, SRE3 H. PUMP MOTOR ASSEMBLY

D-0, E-0, E-1, F-0,
F-1, G-0, G-1, G-2,
H-0, H-1

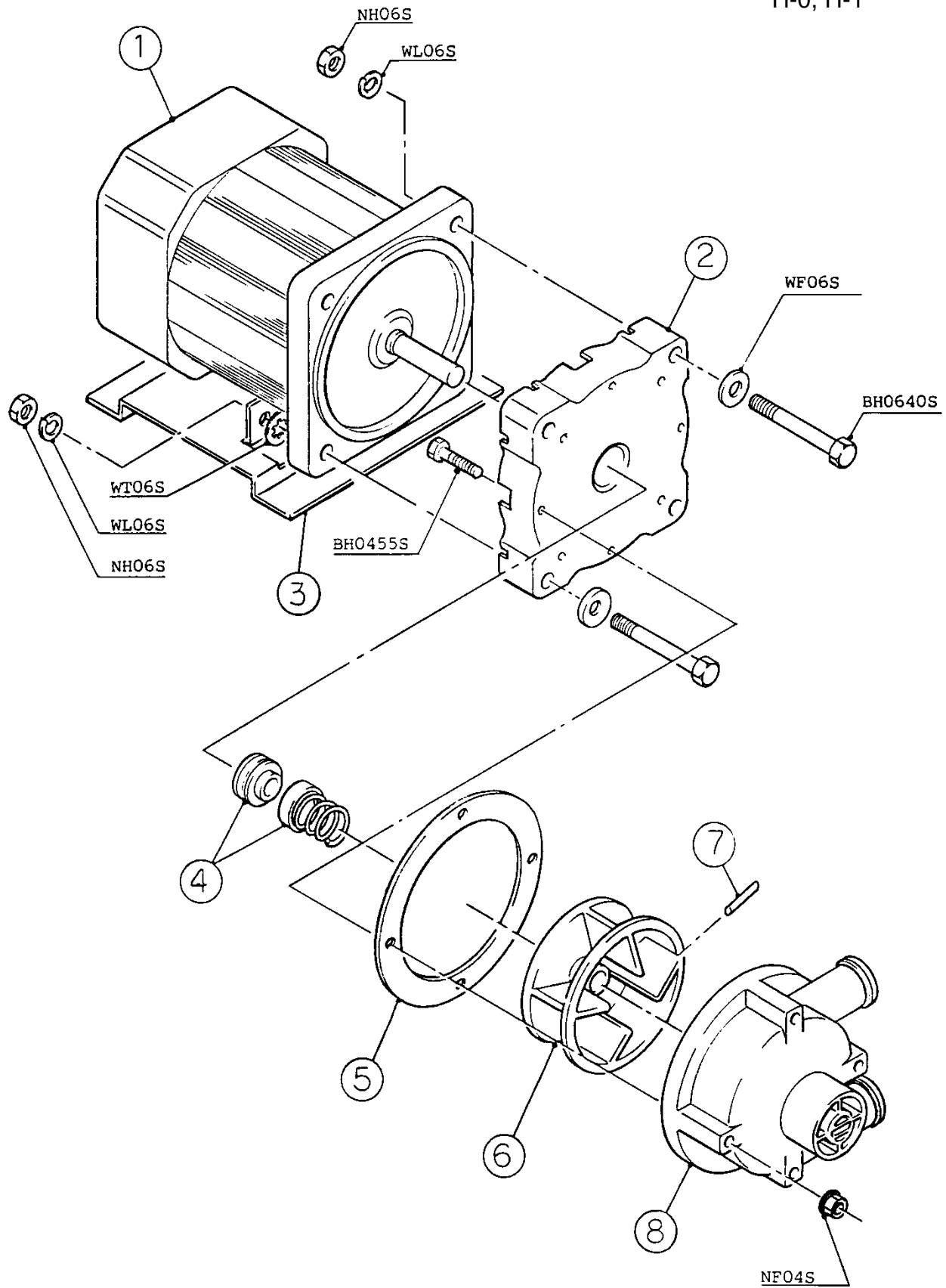

HA

MODEL: KM-1600SWE, SWE3, SRE, SRE3 TITLE: H. PUMP MOTOR ASSEMBLY													
INDEX NO.	DESCRIPTION	MATERIAL OR MODEL	PART NUMBER	REQUIRED NUMBER									
				D-0	E-0	E-1	F-0	F-1	G-0	G-1	G-2	H-0	H-1
1	PUMP MOTOR	M91A60SP201	2U0106-01	1	1	1	1	1	1	1	1	1	1
2	PUMP FLANGE	PC	215662-01	1	1	1	1	1	1	1	1	1	1
3	PUMP MOTOR BRACKET	SS	323904-01	1	1	1	1	1	1	1	1	1	1
4	MECHANICAL SEAL	H5-PN, 8 mm.	428545-01	1	1	1	1	1	1	1	1	1	1
5	PACKING	EPDM	428547-01	1	1	1	1	1	1	1	1	1	1
6	IMPELLER	ABS	436584-01	1	1	1	1	1	1	1	1	1	1
7	PIN	SS	414102-01	1	1	1	1	1	1	1	1	1	1
8	PUMP HOUSING	ABS	213687-01	1	1	1	1	1	1	1	1	1	1

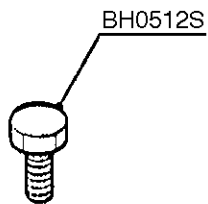
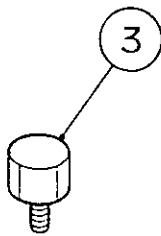
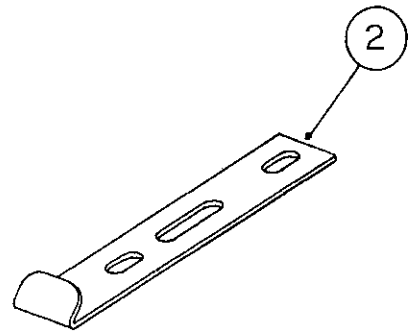
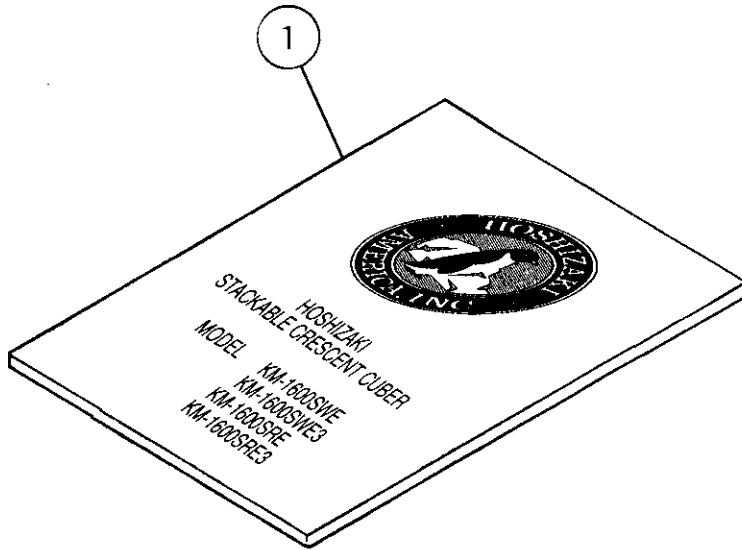

HA

KM-1600SWE, SWE3, SRE, SRE3

H. ACCESSORIES

F-1, G-0, G-1, G-2, H-0, H-1

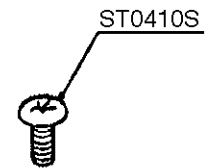
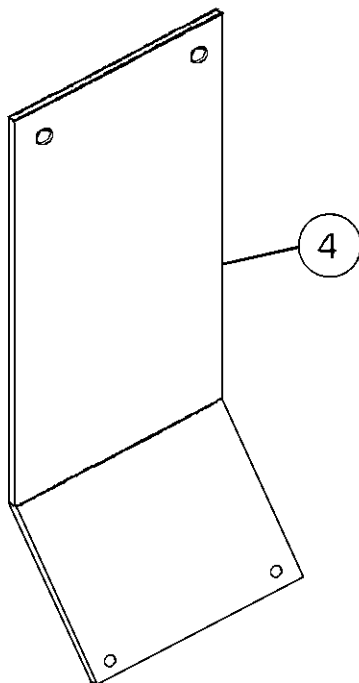
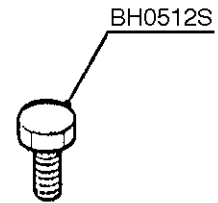
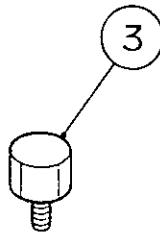
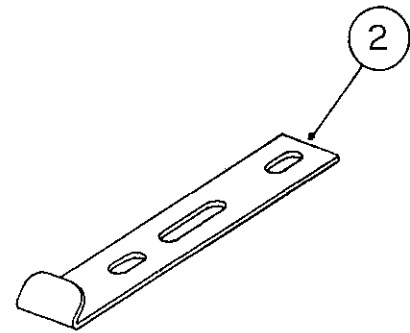
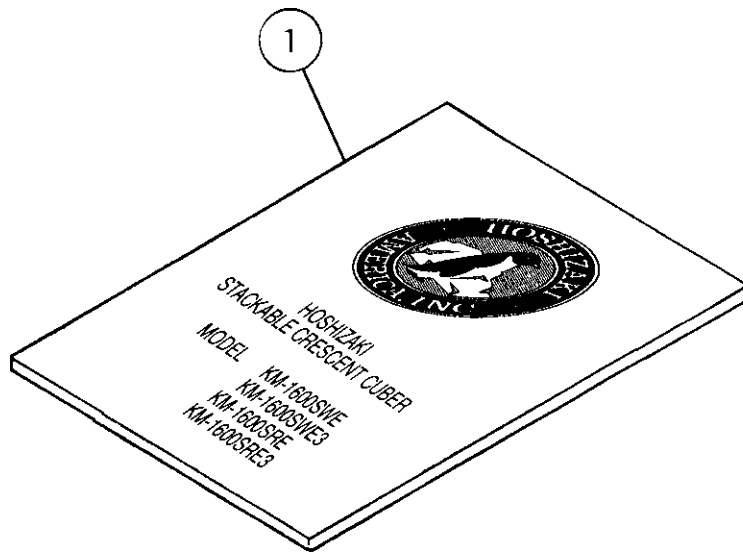

MODEL: KM-1600SWE, SWE3, SRE, SRE3 TITLE: J. ACCESSORIES														
INDEX NO.	DESCRIPTION	MATERIAL OR MODEL	PART NUMBER	REQUIRED NUMBER										
				D-0	E-0	E-1	F-0	F-1	G-0	G-1	G-2	H-0	H-1	
1	INSTRUCTION MANUAL	PAPER	91U1QJ10A	1	1	1	1	x1						
		PAPER	91U1QJ10B					o1	1	1	1	1	1	
2	UNIVERSAL BRACE	GS	4A0363-01	2	2	2	2	2	2	2	2	2	2	
3	THUMBSCREW	ABS, SS	415949G01	1	1	1	1	1	1	1	1	1	1	
4	THERMOSTAT EXTENSION BRACKET	SS	3A0408-01					1	1	1	1	1	1	