

C2648 Service Parts

This is the service parts list for the C2648.
In December 2014 it was revised to a D series, which designates a new cabinet.

Contents

Exterior Panels - A Series	Page 2
Exterior Panels - D Series	Page 3
Cabinet Structure.....	Page 4
Interior Components, Left View	Page 5
Interior Components, Right View.....	Page 6
Refrigeration System	Page 7
Freezing Compartment.....	Page 8
Control Box Components	Page 9
PRC241 Condenser	Page 10
Schematic Diagram- A Series	Page 11
Wiring Diagram- A Series.....	Page 12
Schematic Diagram- D Series.....	Page 13
Wiring Diagram- D Series	Page 14

C2648 Service Parts

Exterior Panels - A Series

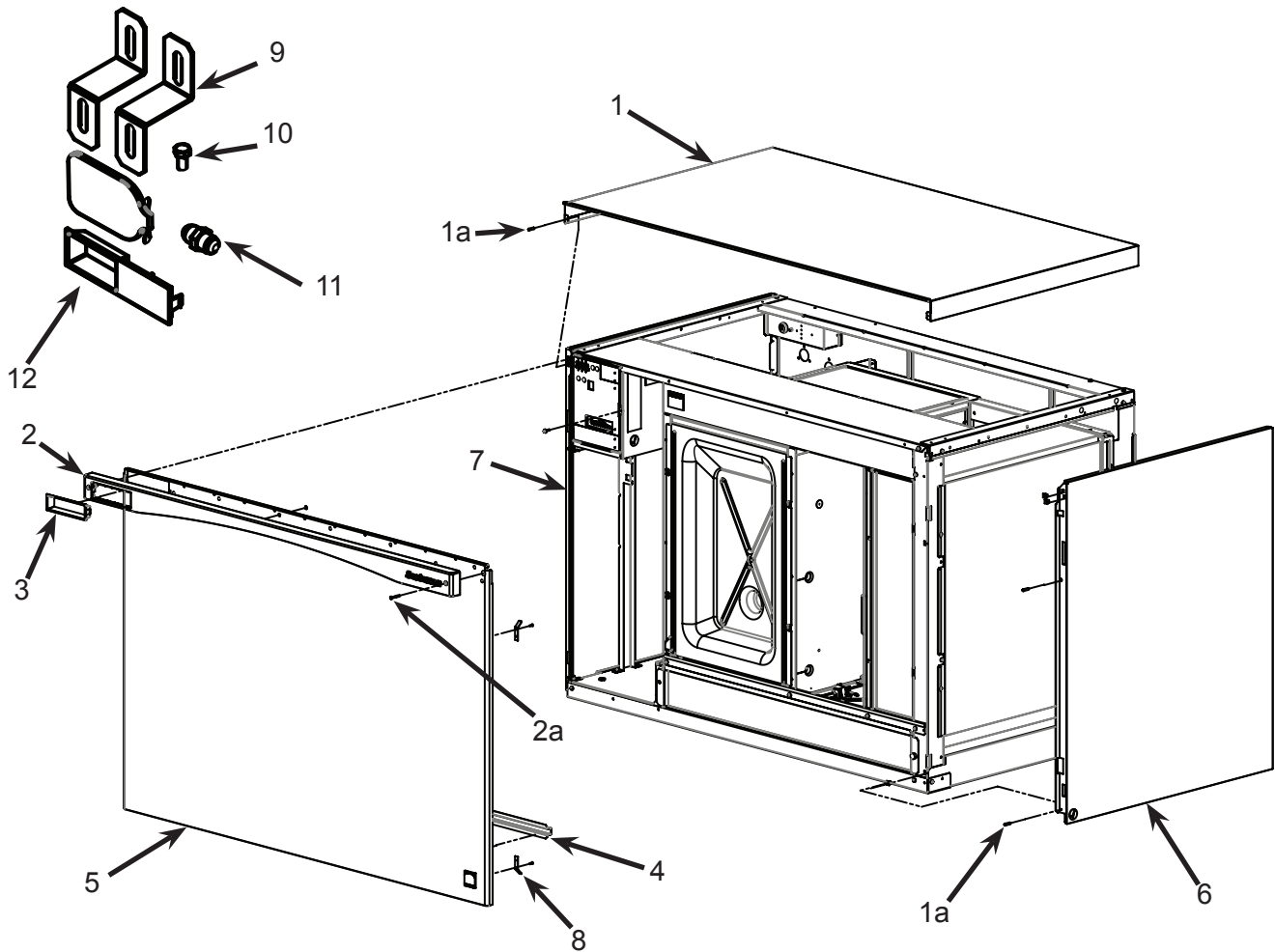

Item Number	Part Number	Description
1	A39777-021	Top panel
1a	03-1404-12	Screw
2	02-4214-03	Trim strip
3	02-4284-01	Bezel
4	A39045-001	Stiffener
5	A39740-021	Front panel assembly, includes items 2, 2a, 3, 4, and 8.
6	A39741-021	Right side panel
7	A39776-021	Left side panel
8	A39751-001	Side panel bracket

Items shipped in installation package:

10	03-1405-13	Screw
----	------------	-------

C2648 Service Parts

Exterior Panels - D Series

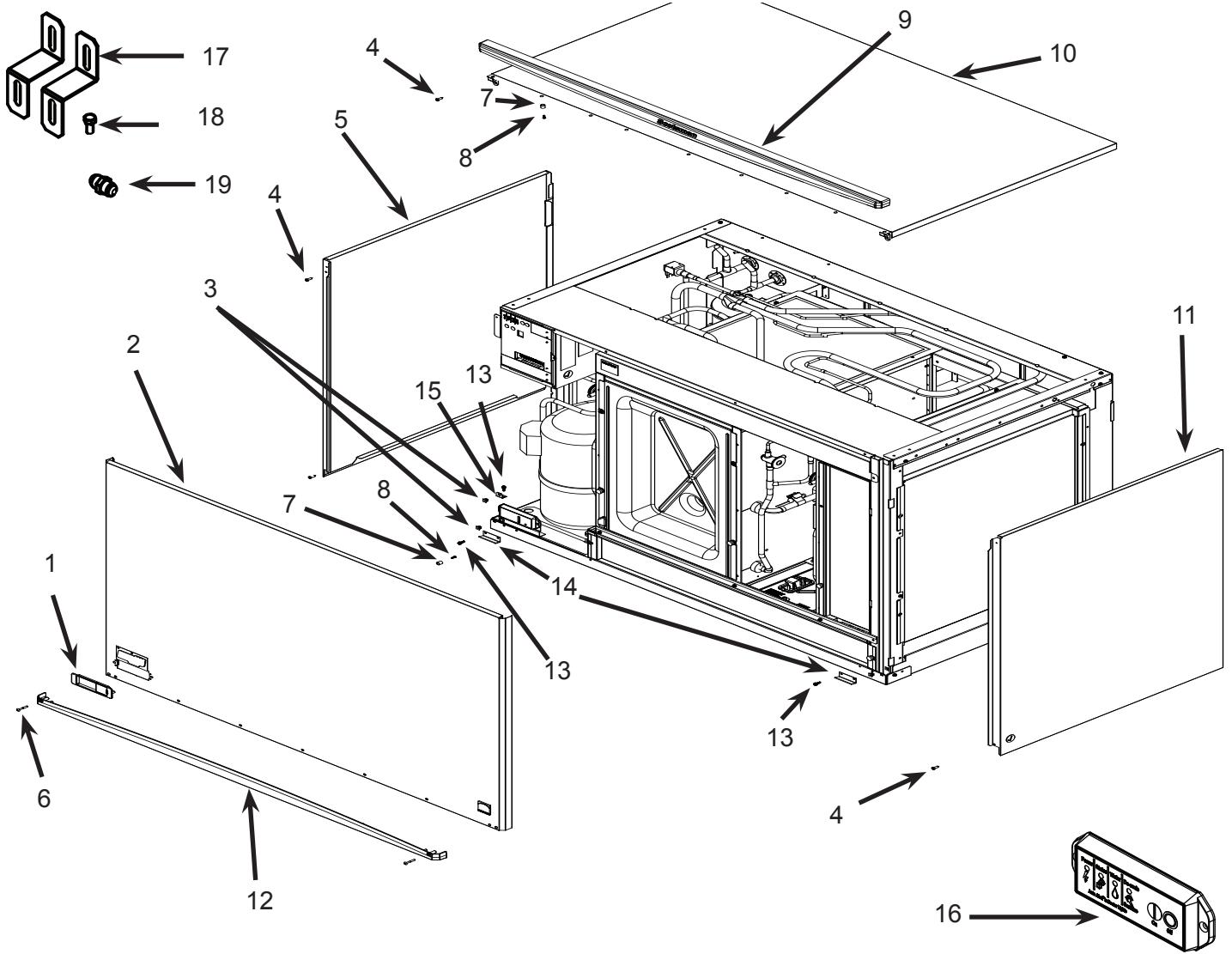

Item Number	Part Number	Description	Item Number	Part Number	Description
1	02-4821-02	Bezel, Includes Standard Door	13	03-3868-02	Screw #8 X 1/2
1A	02-4822-01	Standard Bezel Door (Door Only)	14	A40409-001	Support
1B	02-4822-02	Secure Bezel Door (Door Only)	15	A40408-001	Panel Bracket
2	A40308-035	Front Panel Assembly, Includes Items 1,20 & 21	16	11-0622-21	Lower Switch Panel W/ Harness
3	03-3804-01	Screw Receptacle	17	A39708-001	Machine Support Bracket
4	03-1410-10	Screw #8 X .50	18	03-1405-13	Hex Cap Screw 5/16-18 X 5/8
5	A40392-001	Left Side Panel	19	16-1036-01	Water Inlet Fitting
6	03-1735-03	Screw			
7	02-4824-01	Spacer			
8	03-3836-02	Screw #8 3/8			
9	02-4819-03	Top Trim Strip			
10	A40309-024	Top Panel			
11	A40391-001	Right Side Panel			
12	02-4820-03	Bottom Trim Strip			

C2648 Service Parts

Cabinet Structure

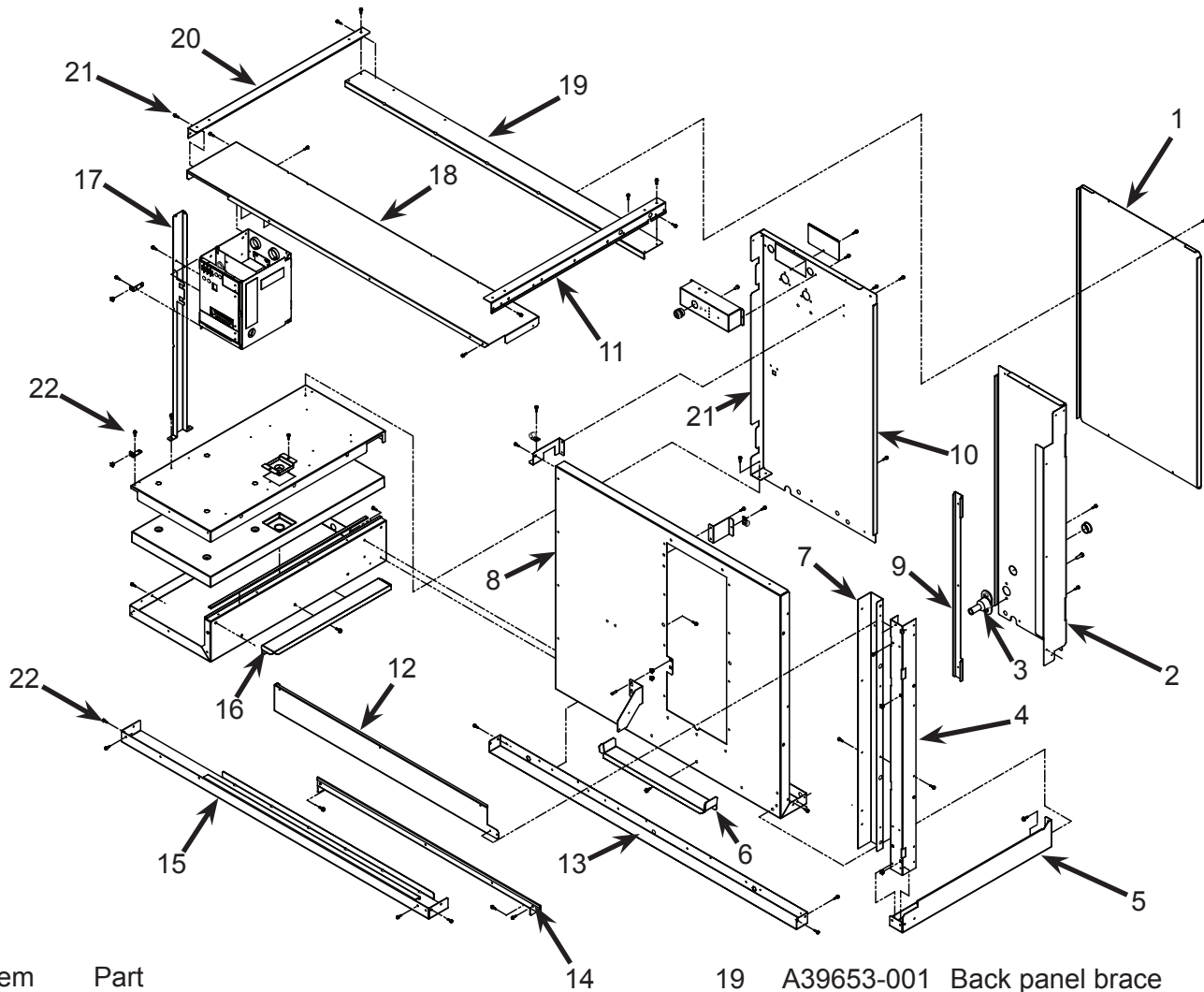

Item Number	Part Number	Description
1	A39703-001	Back panel, ctr
2	A39642-001	Back panel, rt
3	02-3692-21	Drain fitting
4	A39639-001	Right support, outer
5	A39635-001	Base, right
6	A39659-001	Sump bracket, back
7	A39640-001	Right support, inner
8	A39638-001	Back wall
9	A39779-001	Rt side panel bracket
10	A39641-001	Back panel, left
11	A39652-001	Support bracket
12	A39651-001	Evap top support
13	A39634-001	Back brace
14	A39649-001	Evap support
15	A39636-001	Front brace
16	A39658-001	Sump support, left
17	A39650-001	Control box support
18	A39646-001	Front support bracket
19	A39653-001	Back panel brace
20	A39652-001	Support bracket
21	A39641-001	Back panel
22	03-3868-02	Screw, phillips hex

C2648 Service Parts

Interior Components, Left View

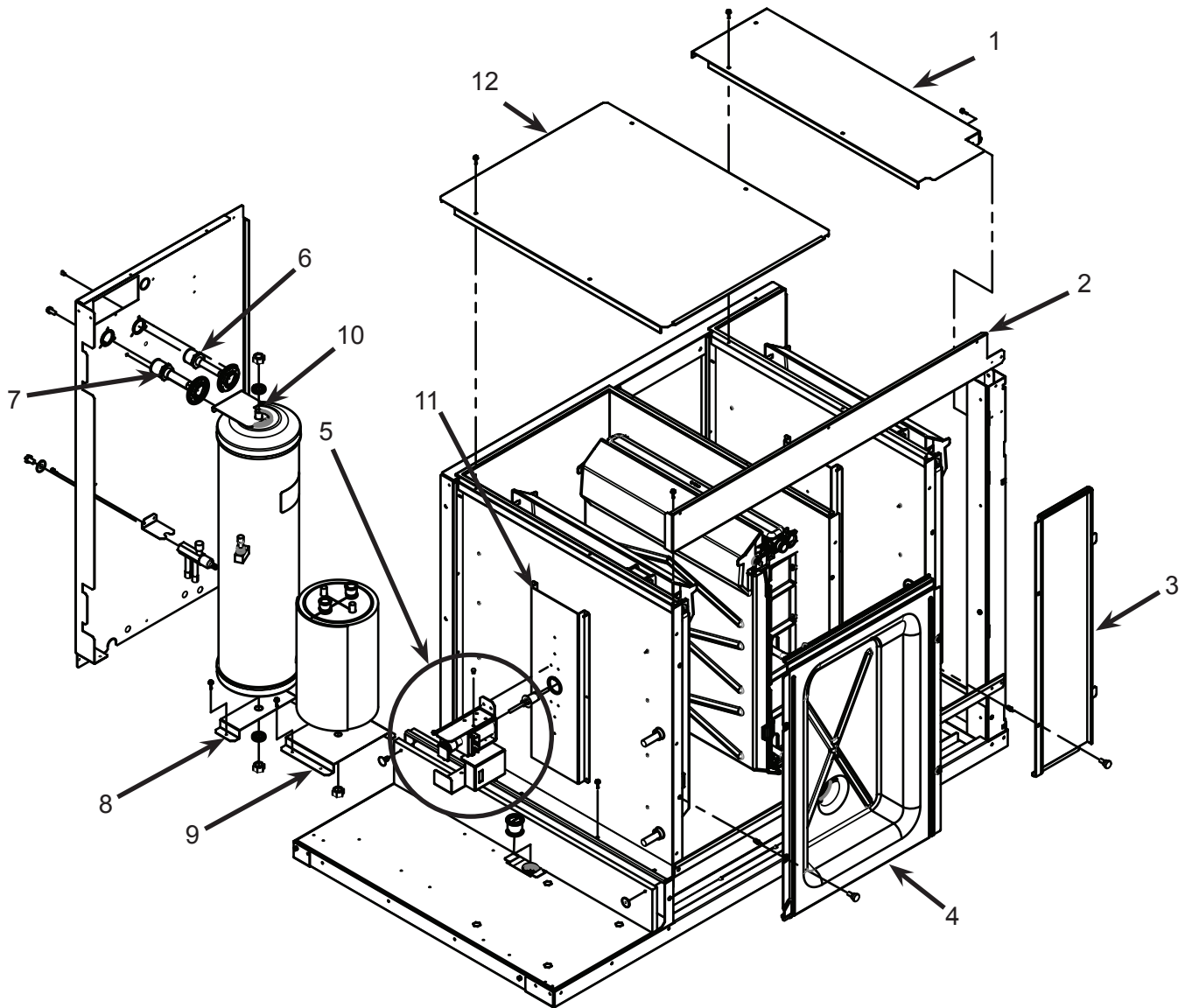

Item Number	Part Number	Description
1	A39704-001	Evap top, 1 plate
2	A39651-001	Evap top support
3	A39705-001	Evap cover, right
4	02-4184-01	Evap cover, center
5	12-3060-22	Harvest assist*
6	16-0850-01	Quick connect, 1/2
7	16-0850-05	Quick connect, 5/8
8	A37212-001	Receiver bracket bottom
9	A37948-001	Accumulator bracket
10	A37211-001	Receiver bracket top
11	A39657-001	HA mounting bracket
12	A39706-001	Evap top, 2 plate

* To change the two right harvest assist solenoids to 12-3060-22, replace them both at the same time.

C2648 Service Parts

Interior Components, Right View

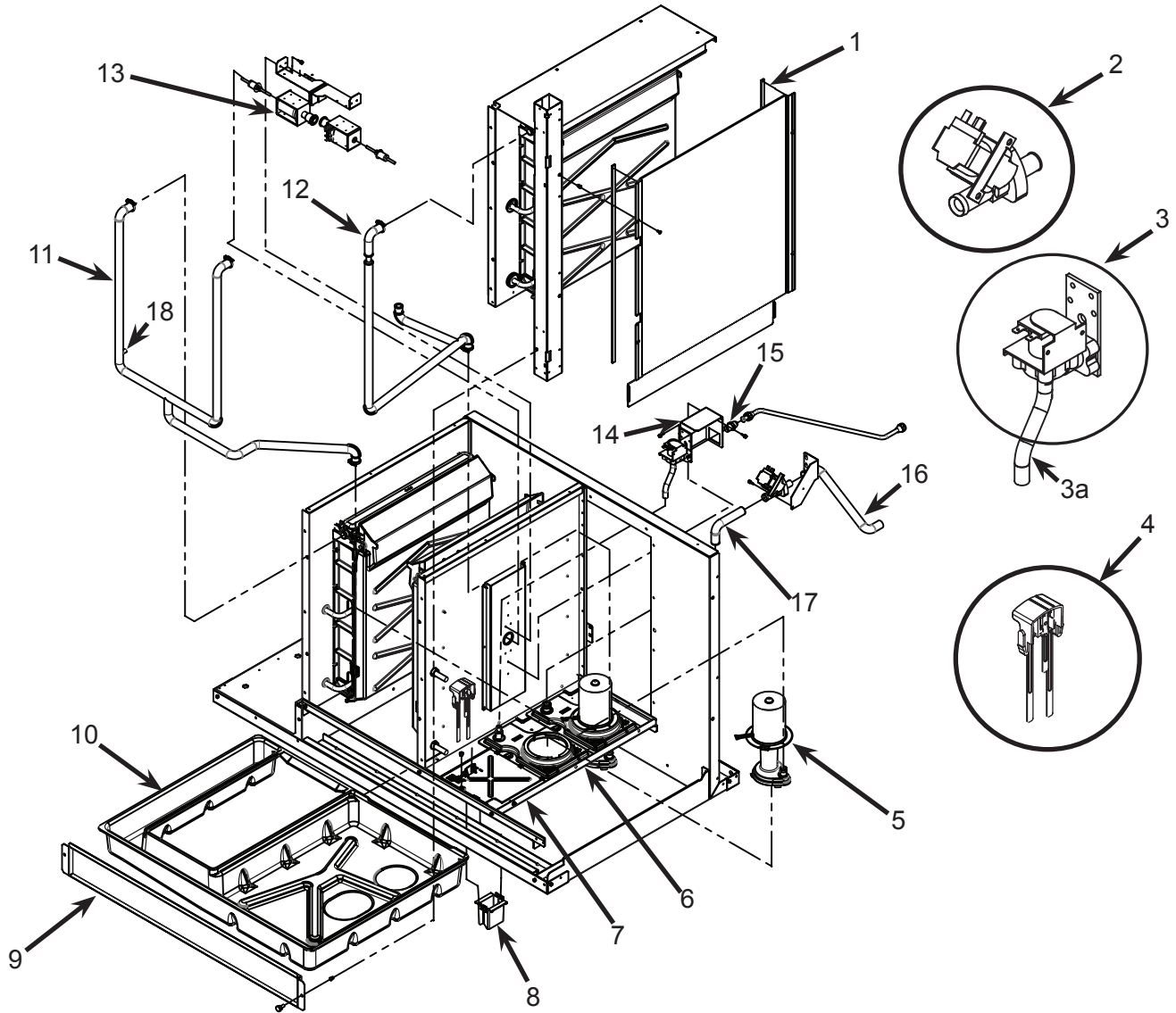

Item Number	Part Number	Description
1	A39778-001	Right side liner
2	11-0514-01	Purge valve
3	12-2922-03	Inlet water sol valve
4	A39829-001	Water level sensor
5	12-2920-22	Water pump
6	02-4177-04	Pump bracket, front
	02-4177-05	Pump bracket, back
7	02-4166-02	Sump cover
8	02-4332-01	Probe cover
9	A39702-001	Sump cover, front
10	02-4554-01	Sump
11	02-4552-01	Hose, 2 plates
12	02-4553-01	Hose, 1 plate
13	A39647-001	Harv assist bracket
14	A39808-001	Inlet water vlve bracket
15	16-0355-00	Coupling half
16	A39655-002	Drain hose, out
17	A39655-001	Drain hose, in
18	11-0572-21	Temp sensor set

C2648 Service Parts

Refrigeration System

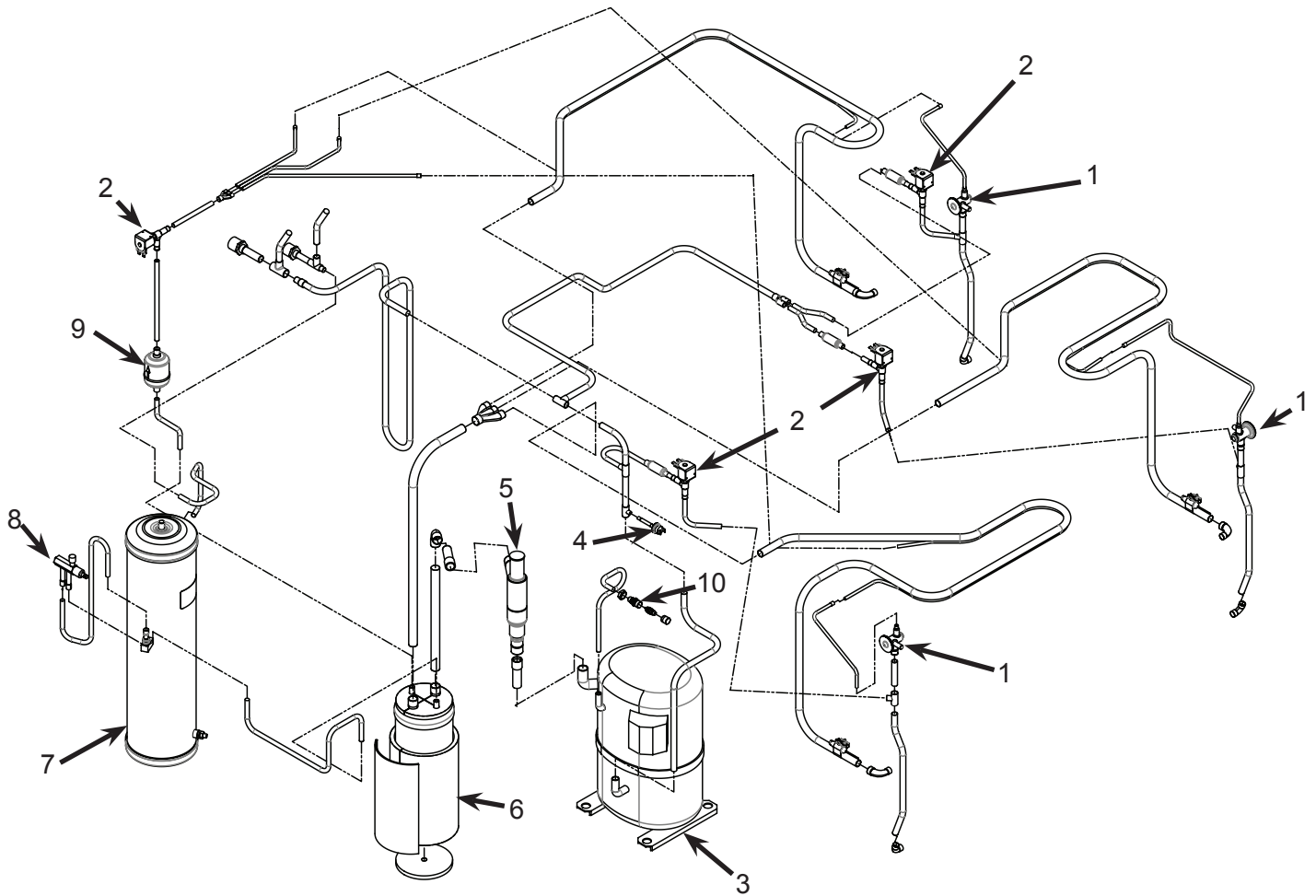

Item Number	Part Number	Description
1	16-1142-02	TXV
	19-0599-06	Insulation for TXV
2	11-0591-01	Hot gas valve / liquid line valve, no coil
2a	11-0590-02	Coil for HGV
3	18-8923-23	Compressor, 3 phase. Overload is internal. CS27K6E-TF5-276
4	11-0501-22	High pressure cut out
5	16-1096-23	OPR valve
6	16-1122-21	Accumulator with insulation
7	16-1177-01	Receiver
8	16-1030-01	Receiver outlet valve
9	02-4557-01	Dryer
10	16-1137-01	Access valve seat
	16-1139-01	Access valve core
	16-1140-01	Access valve cap

C2648 Service Parts

Freezing Compartment

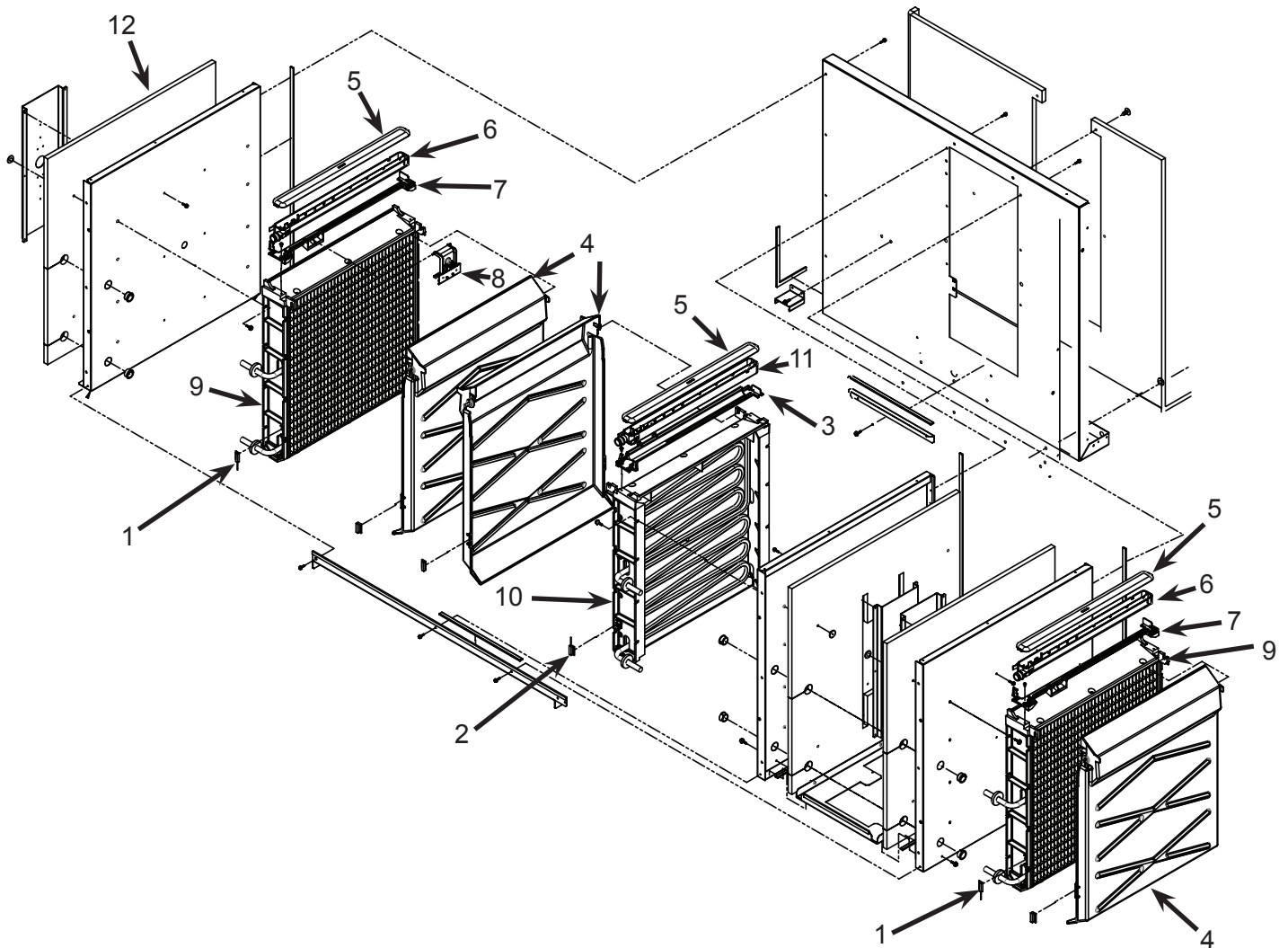

Item Number	Part Number	Description
1	11-0563-06	Curtain switch
2	11-0563-03	Curtain switch
3	02-4205-02	Distributor mounting bracket
4	02-4611-21	Curtain, includes magnet
5	02-4065-01	Water distributor cover
6	02-4064-01	Water distributor
7	02-4205-01	Distributor mounting bracket
8	A39031-021	Ice thickness sensor
9	A38628-021	Left & Right evaporator, small cube
	A38628-022	Left & Right evaporator, medium cube
10	A38628-023	Center evaporator, small cube
	A38628-024	Center evaporator, medium cube
11	02-4064-02	Water distributor
12	02-4608-01	Insulation pad

C2648 Service Parts

Control Box Components

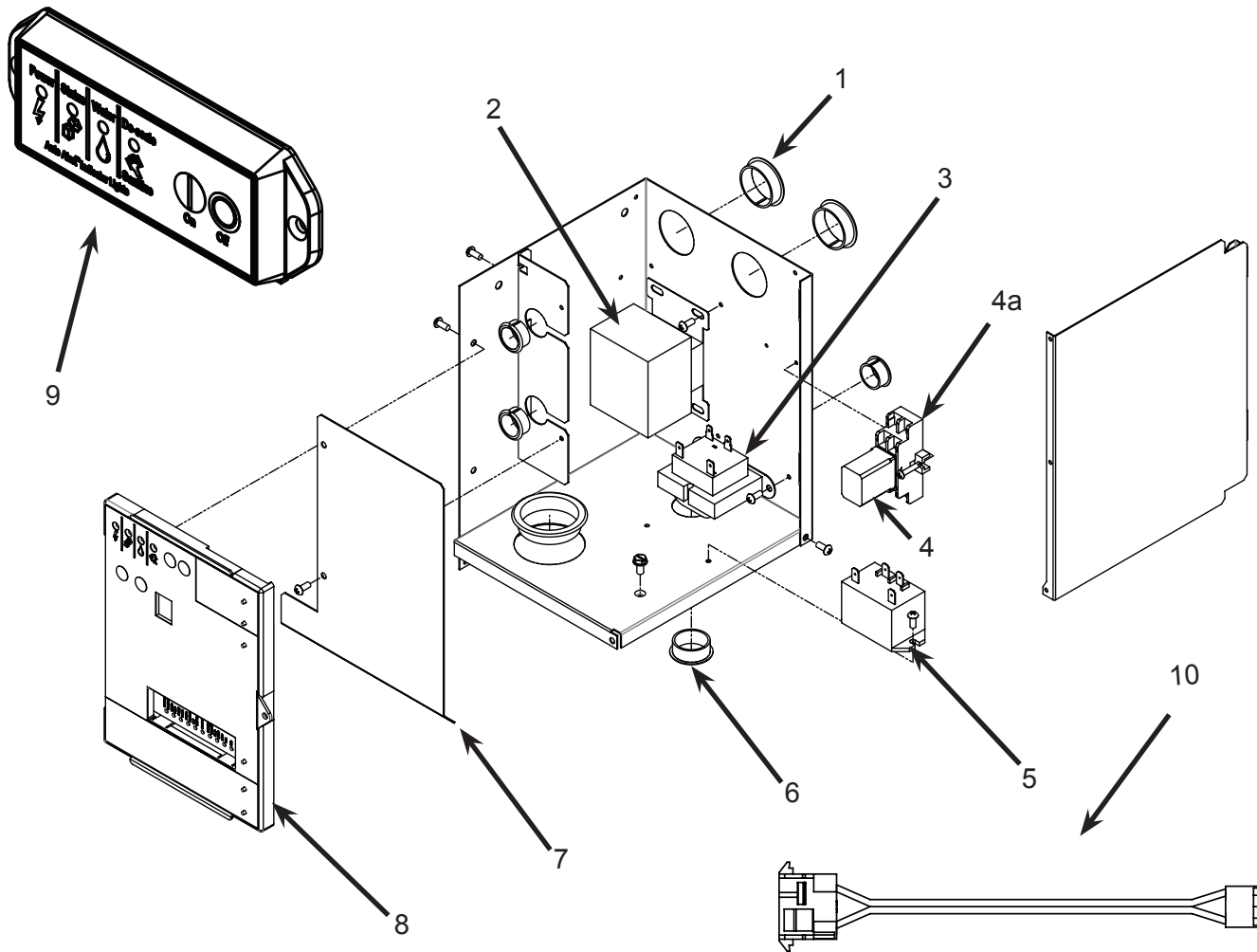

Item Number	Part Number	Description
1	12-1213-20	Snap bushing
2	12-2533-02	Contactor
3	12-2924-02	Transformer
4	12-2949-03	Relay
4a	12-2949-02	Base
5	12-3031-01	High capacity relay
6	12-1213-11	Snap bushing
7	A39216-001	Barrier
8	11-0621-21	Controller, fits all Prodigy cubers
	11-0550-28	Controller, thru C series
	02-4076-01	Control box door
	02-4189-01	Overlay label
9	11-0622-21	Lower Switch Panel W/ Harness
10	12-3030-01	Harness for the 3rd Curtain Switch

C2648 Service Parts

PRC241 Condenser

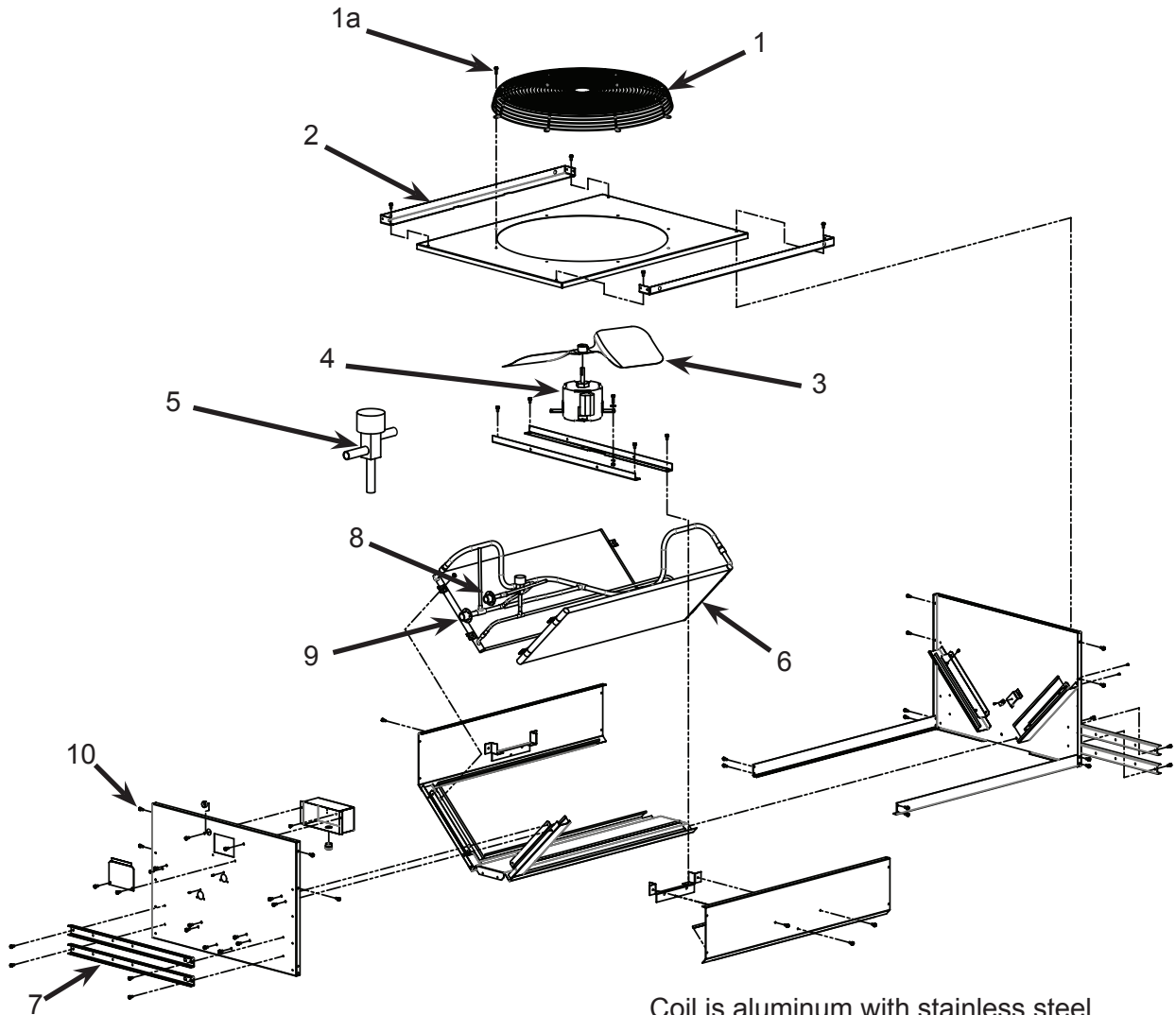

Coil is aluminum with stainless steel copper stubs. Do not overheat

Item Number	Part Number	Description
1	02-3770-01	Fan Guard
1a	03-1645-03	Screw
2	A39756-001	Leg brace
3	18-8820-01	Fan blade
4	12-2717-01	Fan motor
	18-8878-01	Fan motor capacitor
5	11-0422-22	Head pressure valve
6	18-8945-22	Condenser coil
7	A37169-001	Leg
8	16-0850-01	Liquid quick connect
9	16-0850-05	Disch. quick connect
10	03-1645-01	Screw, fits legs & other

C2648 Service Parts

Schematic Diagram- A Series

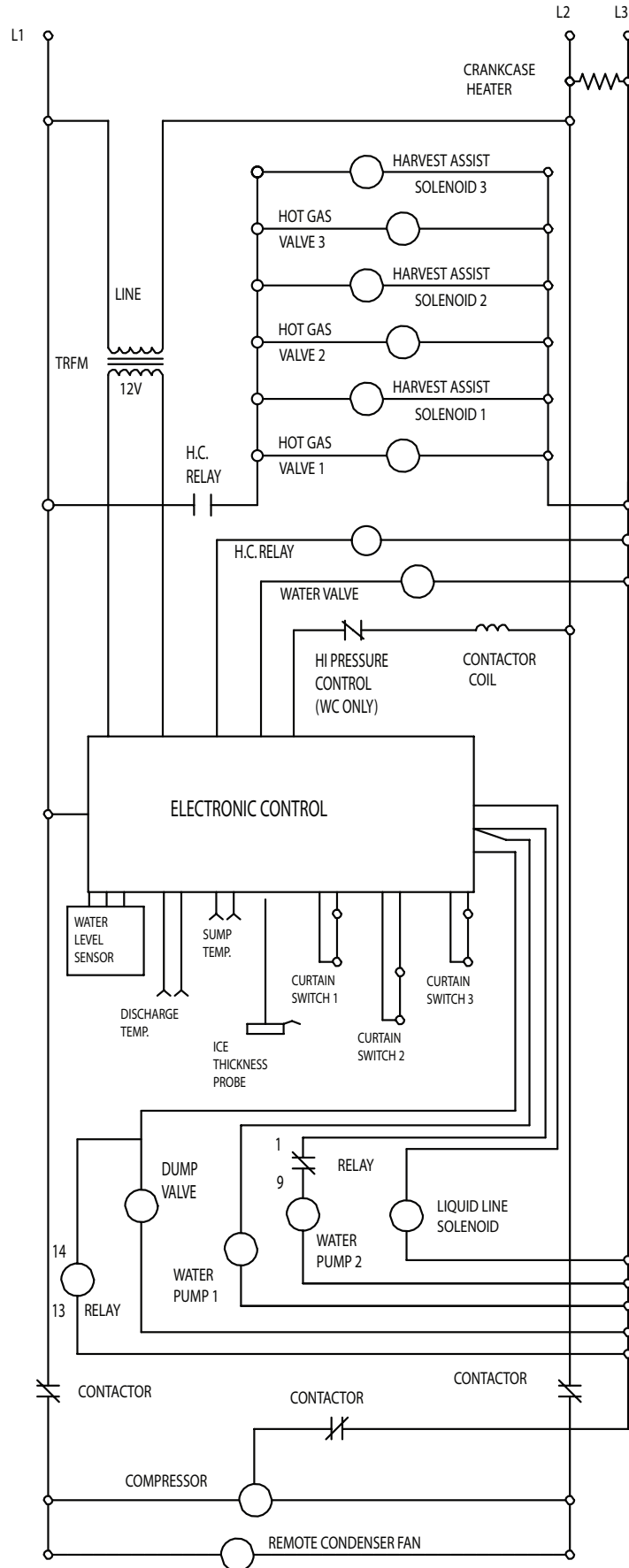

C2648 Service Parts

Wiring Diagram- A Series

17-3317-01

USE COPPER CONDUCTORS ONLY

DASHED LINES INDICATE FIELD WIRING WHICH MUST BE INSTALLED IN ACCORDANCE WITH THE NATIONAL ELECTRICAL CODE AND ALL STATE AND LOCAL CODES.

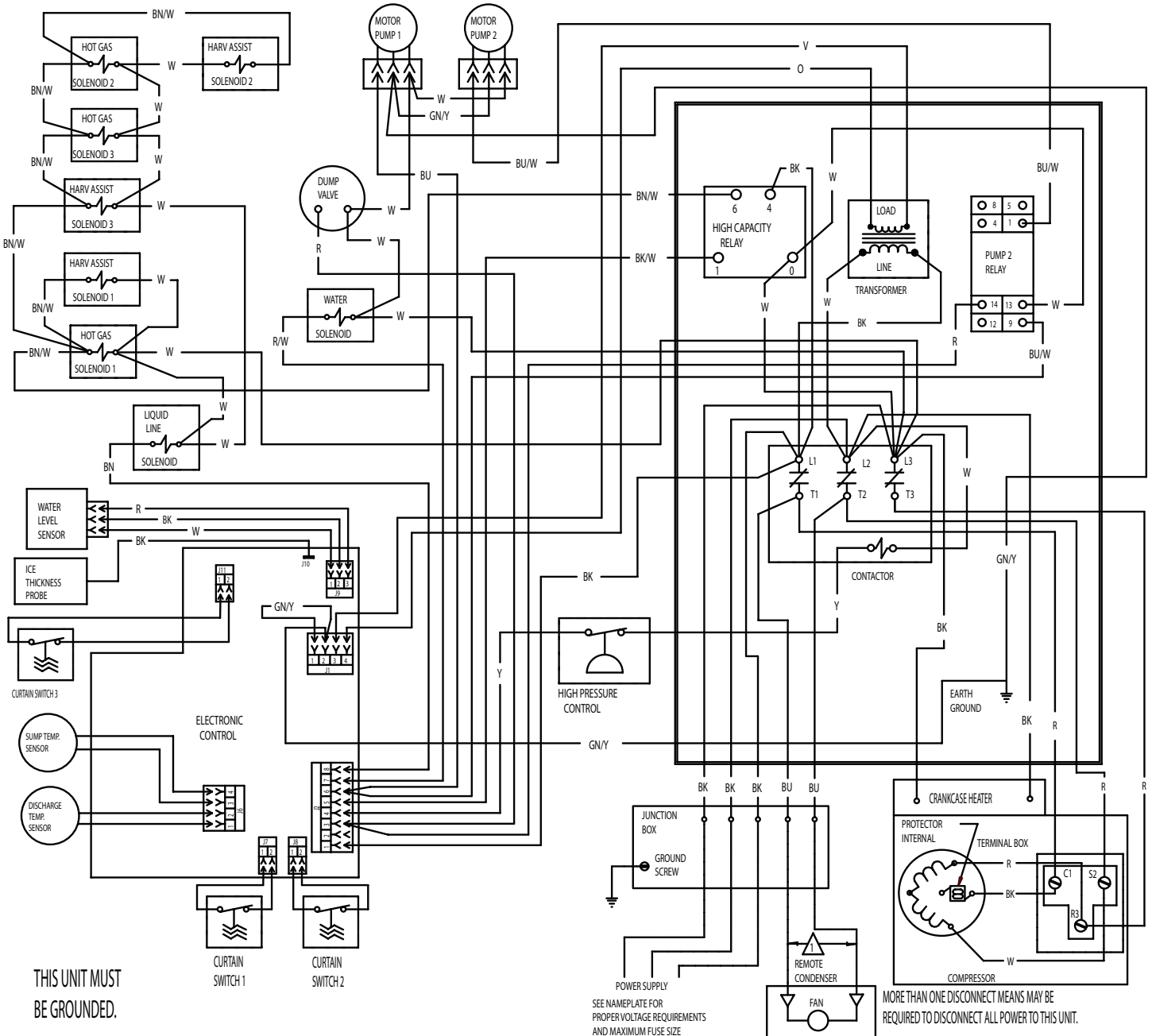

THIS UNIT MUST BE GROUNDDED.

POWER SUPPLY
SEE NAMEPLATE FOR PROPER VOLTAGE REQUIREMENTS AND MAXIMUM FUSE SIZE

MORE THAN ONE DISCONNECT MEANS MAY BE REQUIRED TO DISCONNECT ALL POWER TO THIS UNIT.

C2648 Service Parts

Schematic Diagram- D Series

⚠ DASHED LINES INDICATE FIELD WIRING WHICH MUST BE INSTALLED IN ACCORDANCE WITH THE NATIONAL ELECTRICAL CODE AND ALL STATE AND LOCAL CODES.

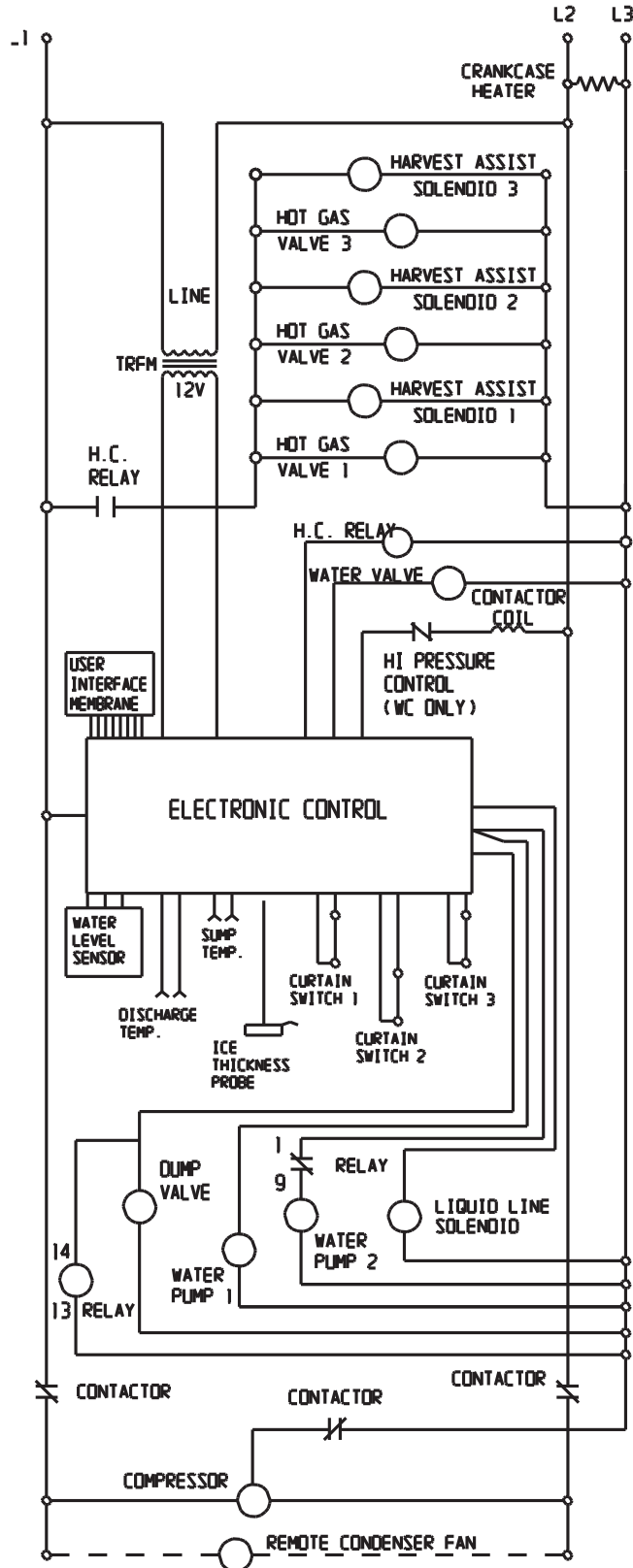

C2648 Service Parts

Wiring Diagram- D Series

17-3544-01

USE COPPER CONDUCTORS ONLY

