

AMBASSADOR REVERSE LIFT

US PATENT NO'S: [7,249,386 B2] [D507,769 S]

MEASUREMENT TAKEN WITH THE LIFT AT FULL LOAD

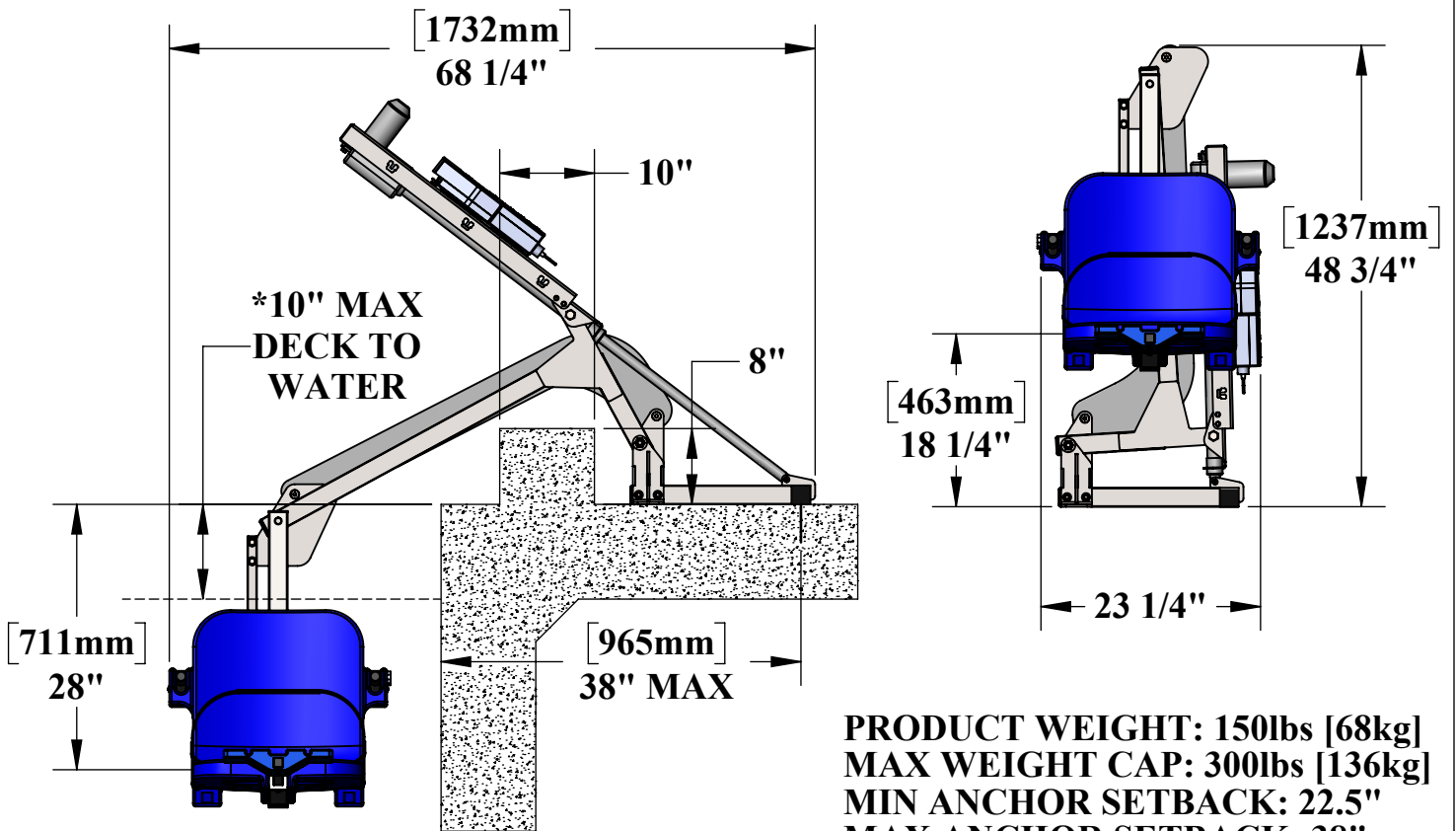

PRODUCT WEIGHT: 150lbs [68kg]
MAX WEIGHT CAP: 300lbs [136kg]
MIN ANCHOR SETBACK: 22.5"
MAX ANCHOR SETBACK: 38"
MAX WATER DRAFT: *10"

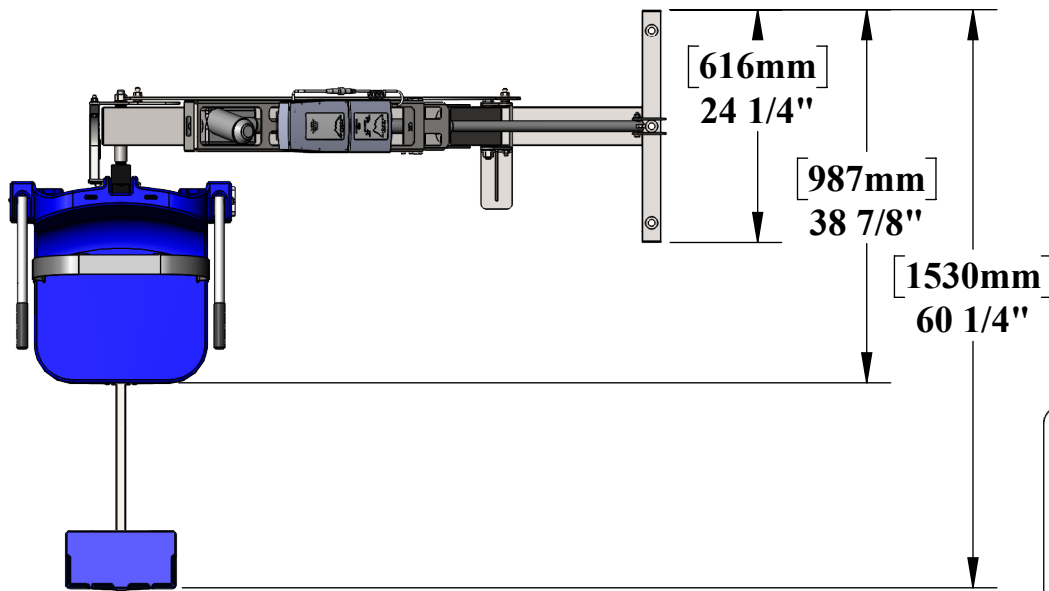

Inspected And Verified To Meet
 Applicable Sections of ADA
 Guidelines Section 1009.2 By

wyle
 laboratories

A Registered ISO 9001
 Laboratory



9889 GARRYMORE LANE
 MISSOULA, MT 59808
 (406) 549-0769
 FAX (406) 549-2602

NOTE:
 *SPECIFICATIONS ARE SUBJECT TO CHANGE WITHOUT NOTICE

PRODUCT: AMBASSADOR REVERSE	
PART #: F-PPXR-D-R	
SCALE: 1:20	DATE: 6/14/2019
DRAWN BY: KR	REVISION: 03