

POWERHOUSE CHALLENGER SERIES

First Team Sports, Inc. rev.05/08/2019

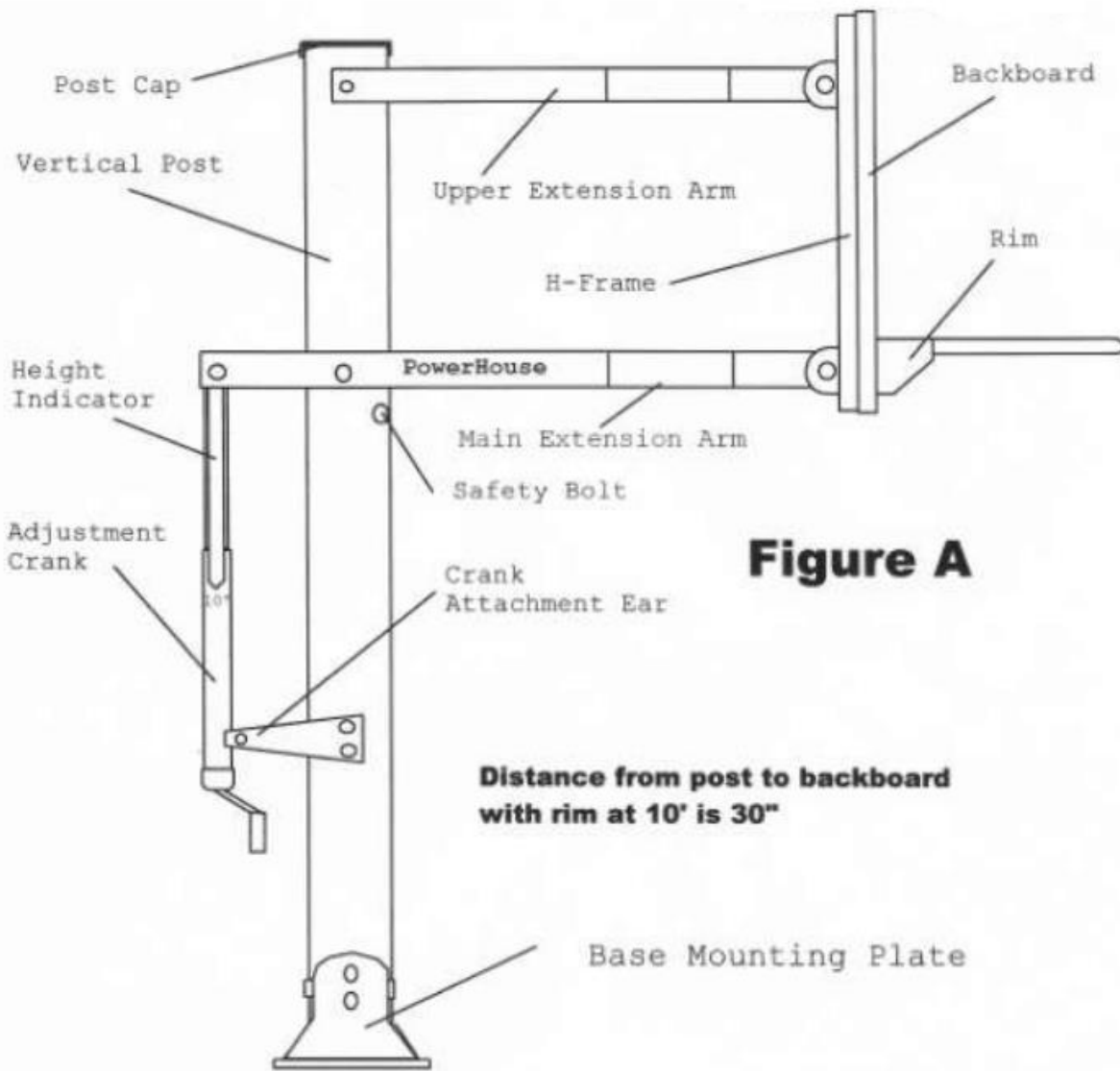

Bill of Materials

- | | | |
|-------------------------------|-----------------------------|---|
| (1) Rim | (1) Anchor Footing Template | (3) 1/2" x 6" Hex Bolt (for ears & crank) |
| (1) Backboard | (4) Anchor Footing Rebar | (1) 1/2" x 5 1/2" Hex Bolt (safety bolt) |
| (1) Vertical Post | (4) 5/8" Anchor Bolt | (3) 1/2" x 9" Hex Bolt (arms) |
| (2) Main Extension Arm | (16) 5/8" Hex Nut | (4) 1/2" x 2 1/4" Hex Bolt (h-frame) |
| (2) Upper Extension Arm | (8) 5/8" Lock washer | (11) 1/2" Center lock Hex Nut |
| (2) Base Mounting Plate | (8) 5/8" Flat washer | (8) 1/2" Nylon Flat washer |
| (2) Crank Attachment Ear | (1) Height Indicator | (4) 5/16" x 1" Machine Screw |
| (1) Adjustment Crank | (1) 5" Post Cap | (4) 5/16" Flat washer |
| (1) Height Sticker | (4) 5/8" x 1 1/2" Hex Bolt | (4) 5/16" Lock washer |
| (1) H-Frame Backboard Bracket | | (4) 5/16" Hex Nut |

*NOTE: Immediately unpack all components and cross check against bill of materials. Report any shortages to First Team customer service at 1-888-884-6677.

1. Choose the proper location to dig for the concrete footing. Use the distance chart in figure A to help you make your decision. When choosing the exact position to dig, make sure to maximize the amount of playing surface while minimizing possible driveway obstruction.
2. Dig hole 36" deep and 24" square. Be sure to bell out the bottom 12" of the hole to give added stability to the footing. NOTE: If you live in an area where the frost line is below 48" it is advisable to dig to normal frost line. **Do not cheat on the hole size, it is imperative that the hole be a minimum of 36" deep and 24" square!**
3. Assemble the anchor kit as shown in Figure B. First thread a 5/8" hex nut 2 1/2" of the way on to each J-Bolt. Place the threaded end of each J-Bolt through the 4 holes located in the anchor template. Then thread a second 5/8" nut on to each J-Bolt until tight against the template, making sure to keep the J-Bolt hooks pointing in toward the center of the template.
4. For this step you will need: Level; Broomstick; Tape Measure. The 48" x 24" anchor footing will require a little over a 1/3 yard of 3000 psi concrete (18-24 60# sacks of premix concrete). More will be needed if you dig a larger hole. Make certain that you have enough concrete to finish the job. Allowing a portion to dry while you purchase more concrete will weaken the footing.
5. Mix the concrete according to the instructions on the bag. It is better to mix it slightly wet than too dry. Fill the hole full to ground level with as little time between batches as possible. Insert the broomstick in 3 or 4 different places and vibrate up and down to settle the concrete. Submerge the (4) anchor footing rebar pieces into the center of the hole spaced evenly in an 8"x 8" square pattern. Next set the anchor bolt assembly into the wet concrete, vibrate it as it goes in to make sure the concrete fills in around the J-Bolt hooks. Make sure the template is pressed firmly against the top of the wet concrete. Use the level to ensure that it is level in all directions. Additionally, the center line of the J-Bolts must be parallel with the edge of the playing surface. (See figure C)

STOP HERE! Allow footing to cure for seven days before proceeding.

6. Take off the top 5/8" nuts from the J-Bolts, remove the template and discard it.
7. Thread a second 5/8" nut on to each J-Bolt down against the nut embedded in the concrete.
8. Place (1) 5/8" flat washer on top of each 5/8" hex nut in step seven.
9. Secure both Base Mounting Plates to the vertical post as shown in Figure E using the 5/8" x 1 1/2" Hex bolts, lock washers and hex nuts provided. Note: It is recommended to attach using the lock washers and hex nuts to the INSIDE of the post to prevent exposed bolt threads on the outside of post.
10. Next, attach Crank Attachment Ears to the post using (2) 1/2" x 6" hex bolts and 1/2" center lock nuts provided.
*****BE SURE TO BOLT EARS ON IN THE CORRECT DIRECTION AS SHOWN IN FIGURE A. EARS SHOULD BE BOLTED SO THEY POINT AWAY FROM THE SAFETY BOLT HOLE LOCATED NEAR THE TOP OF THE POST. See Figure A for SAFETY BOLT hole location. DO NOT OVERTIGHTEN bolts, doing so will cause the ears to flare out making crank attachment difficult later during assembly!**
11. Place the vertical post down over the footing making sure not to damage the J-Bolt threads. Using (4) 5/8" flat washers, lock washers, and the final (4) 5/8" hex nuts, bolt down post finger tight with Crank Attachment Ears facing away from playing surface.
12. Level the vertical post by adjusting the 5/8" nuts located underneath the base mounting plates. Then tighten top nuts against the top side of the base mounting plates.
13. Slide (1) 1/2" x 9" hex bolts through the second hole on one of the Main Extension Arm tubes. Then slide (1) 1/2" nylon flat washer onto the bolt against the opposite side of the Main Extension Arm tube.

14. Slide the main arm onto vertical post and attach to the lower pivot hole sandwiching the ½” nylon flat washer BETWEEN the extension arm and the side of the vertical post. The nylon flat washer will help guard against metal parts rubbing together and causing paint wear.
15. Repeat this process for the opposite side the post using the second Main Extension Arm, ½” nylon flat washer and secure (finger tight only) with (1) ½” center lock nut.
16. Following the same process and hardware discussed in steps 13-15, attach both Upper Extension Arms to Vertical Post.
17. Next, using your final ½” x 6” hex bolt and ½” center lock nut, attach Adjustment Crank to the Crank Attachment Ears as shown in Figure A.
18. Using your final ½” x 9” hex bolt, attach the top of the Adjustment Crank to the Main Extension Arms making certain to also attach the Height Indicator using the same bolt so that the Height Indicator hangs freely along side of the Adjustment Crank (see Figure A).
19. YOU WILL FIND IT HELPFUL TO LOWER THE UNIT DOWN BY TURNING THE CRANK HANDLE FOR THIS STEP. Hang your H-Frame Backboard Bracket to the ends of all four extension arms using your (4) ½”x 2 ¼” hex bolts, ½” nylon flat washers and ½” center lock nuts. PLEASE NOTE: The extension arms bolt to the INSIDE of the H-Frame with the nylon flat washers sandwiched BETWEEN to prevent paint wear. See FIGURE A.
20. Unpackage backboard and lay it face down on a working surface. Loosen and remove the (4) 5/16”x 1” Machine Screws from the top of the backboard, and discard the plastic shipping block located there.
21. If your backboard is **TEMPERED GLASS** you should find (4) short tubes with vinyl around them (called rim cores) mounted in the four large holes cut in the glass for rim mounting. These rim cores are very important! IF THE RIM CORES ARE NOT MOUNTED IN THE GLASS, LOOK IN THE BACKBOARD BOX THEY MAY HAVE FALLEN OUT DURING SHIPPING. IF THE RIM CORES ARE NOT IN THE BACKBOARD AND CANNOT BE LOCATED DO NOT PROCEED! CALL FIRST TEAM IMMEDIATELY FOR REPLACEMENTS, 1-888-884-6677.

If you backboard is **CLEAR ACRYLIC** your backboard will come with (2) rubber gaskets instead of rim cores mentioned above. When hanging your **ACRYLIC** backboard be certain to sandwich one rubber gasket between the backside of the acrylic and the H-Frame backboard mounting bracket.

22. Next, hang your backboard on the H-Frame mounting bracket lining up the four holes in the top of the H-Frame with the four holes in the aluminum frame at the top of the backboard. Loosely attach backboard to H-Frame at top reusing the 5/16”x 1” machine screws, flat washers, lock washers and hex nuts you removed in step 20. Loosely attach backboard at bottom using the 5/16” hardware provided in your hardware pack. **BE SURE RIM CORES ARE IN PLACE IF YOUR BACKBOARD IS TEMPERED GLASS (FT216 or FT221)! BE SURE TO HAVE ONE GASKET BEHIND BACKBOARD IF YOUR BACKBOARD IS ACRYLIC (FT215, FT220)!**
23. Attach rim using the hardware and instructions provided with your rim.
24. Place Post Cap on top of post. Cap is a snug fit, you may need to tap it into place using a hammer.
25. Tighten all hardware making sure project is square and plum.
26. Using a tape measure, crank unit up until rim reaches 10’. Peel the 10’ height sticker and apply it to the side of the Adjustment Crank lining up the pointed end of the Height Indicator with the mark on the 10’ sticker.

27. Finally, attach (1) $\frac{1}{2}$ " x $5\frac{1}{2}$ " hex bolt and nut securely to the Vertical Post through the holes drilled for the SAFETY BOLT (see Figure A). THIS BOLT IS VERY IMPORTANT AND MUST BE PUT IN PLACE BEFORE PLAYING ON THIS UNIT!!! This bolt is in place to guard against backboard drop in the event of Adjustment Crank failure!

ASSEMBLY OF YOUR POWERHOUSE CHALLENGER SYSTEM IS COMPLETE!!

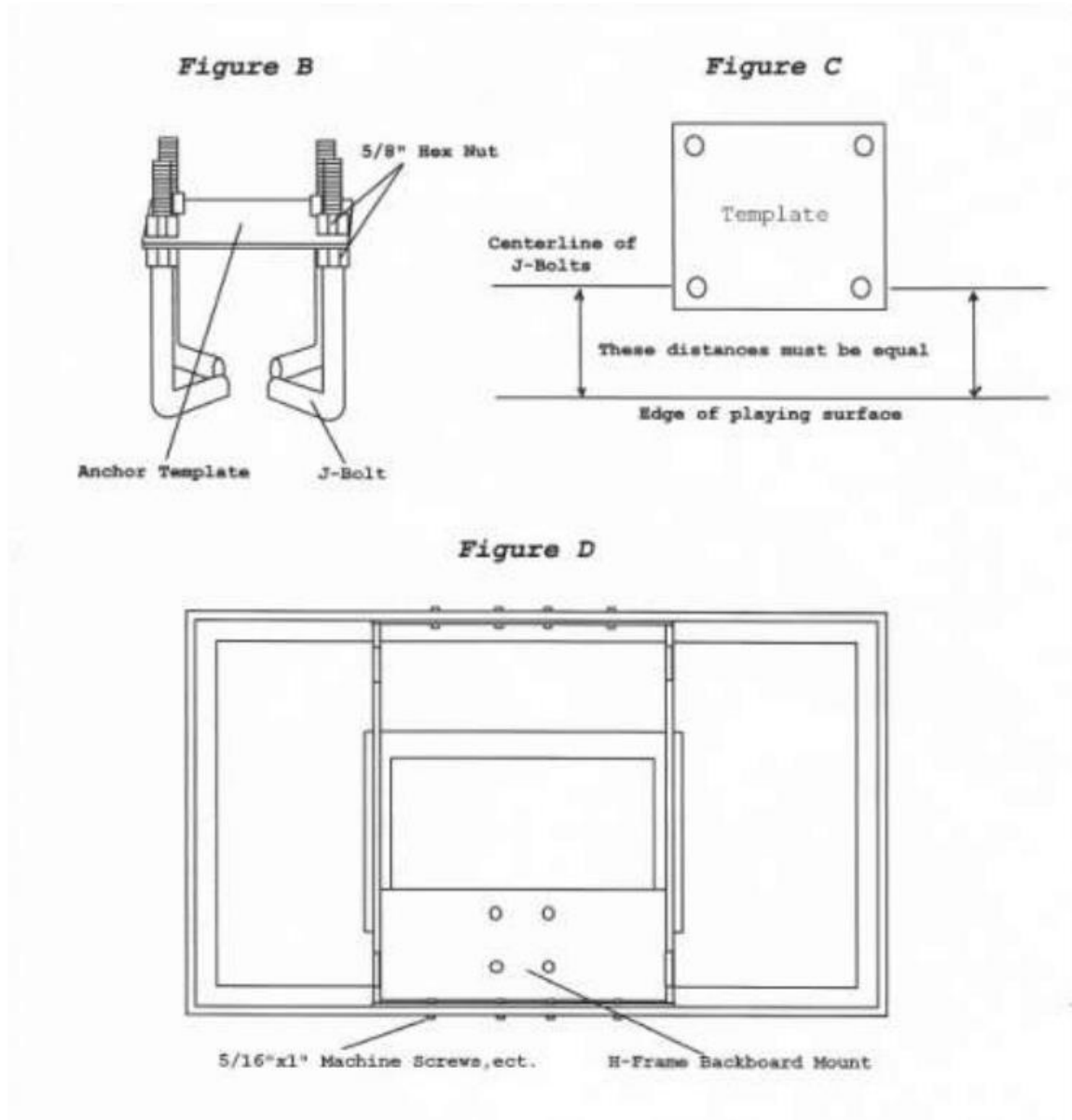

FIGURE E

BASE MOUNTING PLATE ATTACHMENT

