



SOFTPRO WATER SOFTENER INSTALLATION GUIDE

CITY WATER

Brought to you by



READ THIS GUIDE FIRST

Read this manual thoroughly to become familiar with the device and its capabilities before installing or operating your Water Softener. Failure to follow instructions in this manual could result in personal injury or property damage. This manual will also help you to get the most out of your Softener.

- This system and its installation must comply with state and local regulations. Check with your local public works department for plumbing and sanitation codes. In the event the codes conflict with any content in this manual the local codes should be followed. For installations in Massachusetts, Massachusetts Plumbing Code 248 CMR shall be adhered to. Consult your licensed plumber for installation of this system.
- This water Softener is designed to operate on pressures of 30 psi to 125 psi. If the water pressure is higher than the maximum, use a pressure reducing valve in the water supply line to the Softener. However, we do not recommend pressure above 70 psi for the softener or residential plumbing, anything over 70 psi can cause damage to the seals on the softener valve and your plumbing and fixtures.
- This unit can operate at temperatures between 40°F and 110°F (4°C - 43°C). Do not use this water Softener on hot water supplies.
- Do not install this unit where it may be exposed to wet weather, direct sunlight, or temperatures outside of the range specified above unless you take precautions to protect it.
- Avoid pinched O-rings during installation by applying (provided with install kit) NSF certified lubricant to all seals.
- Softeners are commonly exposed to high levels of iron, manganese, sulfur, and sediments. Damage to pistons, seals, and or spacers within the control valve are not covered in this warranty due to the harsh environment.
- It is recommended to regularly inspect and service the control valve on an annual basis. Cleaning and or replacement of piston, seals, and or spacers may be necessary depending on how harsh the conditions are. An Annual Maintenance kit (Part # 60010307) is available for this purpose.
- Do not use water that is microbiologically unsafe without adequate disinfection before or after this system.
- The manufacturer reserves the right to make product improvements which may deviate from the specifications and descriptions stated herein, without obligation to change previously manufactured products or to note the change.
- This publication is based on information available when approved for printing. Continuing design refinement could cause changes that may not be included in this publication. Quality Water Treatment, Inc. reserves the right to change the specifications referred to in this literature at any time, without prior notice.

Table of Contents

HOW YOUR WATER CONDITIONER WORKS.....	4
BEFORE INSTALLATION	5
GENERAL INSTRUCTIONS	7
Unpacking and Inspecting Your New System.....	8
Shipment FAQ	8
Items Included.....	9
REMOVAL OF OLD WATER SOFTENER SYSTEM.....	11
INSTALLING YOUR NEW WATER SOFTENER.....	14
STEP-BY-STEP INSTALL VIDEO	14

General Water Softener Setup Overview	14
Assemble Your Water Softener SYSTEM.....	15
Optional Whole House Filter.....	17
DRAIN INFORMATION	24
RECOMMENDED Option – Install Hose Bib for Treated Soft Water Access.....	26
PROGRAMMING YOUR VALVE	33
SET WATER HARDNESS	35

HOW YOUR WATER CONDITIONER WORKS

WHY WATER GETS HARD AND HOW IT IS SOFTENED

All the freshwater in the world originally falls as rain, snow, or sleet. Surface water is drawn upward by the sun, forming clouds. Then, nearly pure and soft as it starts to fall, it begins to collect impurities as it passes through smog and dust-laden atmosphere. And as it seeps through soil and rocks it gathers hardness, rust, acid, unpleasant tastes and odour.

Water hardness is caused primarily by limestone dissolved from the earth by rainwater. Because of this, in earlier times people who wanted soft water collected rainwater from roofs in rain barrels and cisterns before it picked up hardness from the earth.

Some localities have corrosive water. A softener cannot correct this problem and so its printed warranty disclaims liability for corrosion of plumbing lines, fixtures or appliances.

Iron is a common water problem. The chemical/ physical nature of iron found in natural water supplies is exhibited in four general types: (Applies to private well or surface water applications only.)

- 1) Dissolved Iron—Also called ferrous or “clear water” iron. This type of iron can be removed from the water by the same ion exchange principle that removes the hardness elements, calcium and magnesium. Dissolved iron is soluble in water and is detected by taking a sample of the water to be treated in a clear glass. The water in the glass is initially clear, but on standing exposed to the air, it may gradually turn cloudy or coloured as it oxidizes. Applies to private well or surface water applications only.
- 2) Particulate Iron—Also called ferric or colloidal iron. This type of iron is an undissolved particle of iron. A softener will remove larger particles, but they may not be washed out in regeneration effectively and will eventually foul the ion exchange resin. A filtering treatment will be required to remove this type of iron. Applies to private well or surface water applications only.
- 3) Organic Bound Iron—This type of iron is strongly attached to an organic compound in the water. The ion exchange process alone cannot break this attachment and the softener will not remove this type of iron. Applies to private well or surface water applications only.
- 4) Bacterial Iron—This type of iron is protected inside a bacteria cell. Like the organic bound iron, it is not removed by a water softener. Applies to private well or surface water applications only.

ATTENTION: Iron content must not exceed 1 ppm.

Beyond 1 ppm an iron softener must be used. Periodic media cleaning is required by Pro-Res Cleaner if iron level exceeds 0.3 ppm. Applies to private well or surface water applications only.

When using a softener to remove both hardness and dissolved iron it is important that it regenerates more frequently than ordinarily would be calculated for hardness removal alone. Although many factors and formulas have been used to determine this frequency, it is recommended that the softener be regenerated when it has reached 50–75% of the calculated hardness alone capacity. This will minimize the potential for bed fouling. Applies to private well or surface water applications only.

If you are operating a water softener on clear water iron, regular resin bed cleaning is needed to keep the bed from coating with iron. Even when operating a softener on water with less than the maximum of dissolved iron, regular cleanings should be performed. Clean every six months or more often if iron appears in your conditioned water supply. Use resin bed cleaning compounds carefully following the directions on the container. Applies to private well or surface water applications only.

HOW A WATER SOFTENER WORKS

Water softeners remove hardness in the water by exchanging particles in the water, or ions. They remove hard ions the calcium and magnesium in the water by trading it for sodium ions producing soft water. Unlike the calcium and magnesium, sodium stays dissolved in water and does not form a scale. Sodium also does not interfere with the cleaning action of soaps. The sodium is released by a charged resin contained in the softener, this resin also traps the calcium and magnesium ions. Eventually this resin releases all its sodium and has filled up with other ions, so it then must be regenerated. Regeneration is accomplished by washing the resin with a salt saturated brine solution that removes the calcium and magnesium while replenishing the sodium. Therefore, the softener requires a brine tank and salt. The water softener can run for days before running out of sodium, and when it does, the sodium is replenished in only a matter of a few hours.

NOTE: Do not remove or destroy the serial number. It must be referenced on request for warranty repair or replacement.

CAUTION! Do not use where the water is microbiologically unsafe or with water of unknown quality without adequate disinfection before or after the unit. Applies to private well or surface water applications only.

BEFORE INSTALLATION

All government codes and regulations governing the installation of these devices must be observed.

Check your water hardness.

WARNING! ELECTRICAL SHOCK HAZARD! UNPLUG THE UNIT BEFORE REMOVING THE COVER OR ACCESSING ANY INTERNAL CONTROL PARTS.

CAUTION! The unit should be depressurized before installing or replacing media.

METAL PIPES - GROUNDING NOTE:

If the ground from the electrical panel or breaker box to the water meter or underground copper pipe is tied to the copper water lines and these lines are cut during installation of the Noryl bypass valve and/or poly pipe, an approved grounding strap must be used between the two lines that have been cut in order to maintain continuity. The length of the grounding strap will depend upon the number of units being installed and/or the amount of copper pipe being replaced with plastic pipe.

In all cases where metal pipe was originally used and is later interrupted by poly pipe or the Noryl bypass valve or by physical separation, an approved ground clamp with no less than #6 copper conductor must be used for continuity, to maintain proper metallic pipe bonding.

CAUTION: If the plumbing system is used as the ground leg of the electric supply, continuity should be maintained by installing ground straps around any non-conductive plastic piping used in installation. Check your local electrical code for the correct clamp.

DRAIN LINE INFORMATION

Waste connections or drain outlets shall be designed and constructed to provide for connection to the sanitary waste system through an airgap of 2 pipe diameters or 1 inch (22 mm) whichever is larger.

Never insert a drain line directly into a drain, sewer line, or trap. Always allow an air gap between the drain line and the wastewater to prevent the possibility of sewage being back-siphoned into the conditioner.

WATER PRESSURE INFORMATION

Applies to private well or surface water applications only. If a severe loss in water pressure is observed when the Softener unit is initially placed in service, the softener tank may have been laid on its side during transit. If this occurs, backwash the softener to “reclassify” the media.

Check Your Water Pressure and Pumping Rate - Two water system conditions must be checked carefully to avoid unsatisfactory operation or equipment damage:

- 1) Minimum water pressure required at the Softener tank inlet is 30 psi.
- 2) The pumping rate of your well pump must at least equal the required backwash flow rate of your model.

LOCATE WATER CONDITIONING EQUIPMENT CORRECTLY

Select the location of your Softener tank with care. Various conditions which contribute to proper location are as follows:

- 1) Locate as close as possible to the water supply source.
- 2) Locate as close as possible to a floor or laundry tub drain.

- 3) Locate in the correct relationship to other water conditioning equipment.
- 4) Softener should be located in the supply line before the water heater. Temperatures above 120°F damage softeners.
- 5) Do not install a softener in a location where freezing temperatures occur. Freezing may cause permanent damage to this type of equipment and will void the factory warranty.
- 6) Allow sufficient space around the unit for easy servicing.
- 7) If your water source is a community water supply, a public water supply or you wish to bypass water used for a geothermal heat pump, lawn sprinkling, out-buildings, or other high demand applications.
- 8) Keep the softener out of direct sunlight. The sun's heat may soften and distort plastic parts.
- 9) Determine the best location for your water Softener, bearing in mind the location of your water supply lines, drain line and 120-volt AC electrical outlet. Subjecting the Softener to freezing or temperatures above 43°C (110°F) will void the warranty.

MANUAL WATER BYPASS

In case of an emergency such as softener maintenance, you can isolate your water softener from the water supply using the bypass valve located at the back of the control. In normal operation the bypass is open with the ON/OFF knobs in line with the INLET and OUTLET pipes. To isolate the softener, simply rotate the knobs clockwise (as indicated by the word BYPASS and arrow) until they lock.

You can use your water related fixtures and appliances as the water supply is bypassing the softener. However, the water you use will be hard. To resume treated service, open the bypass valve by rotating the knobs counter-clockwise. **Please make sure bypass knobs are completely open otherwise the unsoftened water could bypass through the valve.**

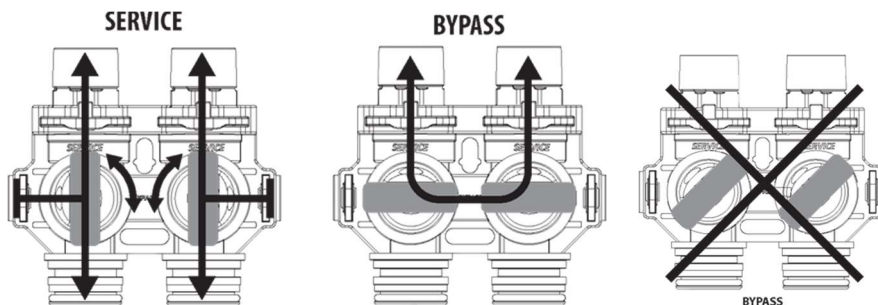

GENERAL INSTRUCTIONS

Below are the installation instructions to get you up and running in no time. We highly recommend that you follow along in our simple installation videos.

Typical Install Times:

- 3 hours for a Handyman/ Plumber

- 4 hours for DIY

Tools Required:

- Flathead Screwdriver
- Phillips Head Screwdriver
- Tongue-and-Groove Pliers (i.e. Channellock)
- Adjustable Wrench
- Pipe Cutter or hacksaw (as applicable per pipe material)

Additional Parts Required:

- Teflon Tape
- ½" ID Teflon Tubing (length to your drain or drainpipe)
- ½" Hose Clamp
- Drainpipe connection fittings
- Additional pipe fittings for rigid drainpipe connections (optional)
- For optional (but recommended) hose bib for treated soft water access: hose bib, "T" fitting and applicable plumbing fittings.
- For optional whole house carbon filters: hose bib, "T" fitting and applicable plumbing fittings.

For PVC Pipe:

- PVC Primer and Glue

For Copper, PEX, and CPVC pipe:

- Quick Connect Fittings (i.e. Optional Quick-connect Kit/ Hose or SharkBite fittings)

UNPACKING AND INSPECTING YOUR NEW SYSTEM

Your new SoftPro water softener system will include the following items below. Before starting, please check that you have all the items, and inspect for any possible damage that may have occurred during shipment. (This new system may have multiple shipments.)

SHIPMENT FAQ

1. Is it OK if some items are delivered on its side or upside-down?

Yes, it is OK.

If your shipment, boxes or other items are delivered to you on its side or upside-down, do not be alarmed. Our team takes additional precautions to ensure that your new system is properly protected. Simply turn the shipment or box right-side up and unpack it.

2. What if there is damage to the exterior of the shipment or boxes?

We got your back. If you find visual damage to the exterior of the boxes, take pictures of the boxes and/or video of the damage before unpacking them. Just because boxes are damaged does not mean the system is damaged, we make sure they are protected.

3. After unpacking, what if there is damage to the valve, tank or other equipment?

We got you. If you find visual damage to any of the parts, please take pictures and/or video of the damage. Then please immediately send us the images/ video, and we will get parts shipped to you.

4. After unpacking, what if there is a missing item?

Easy. If you are missing a part, please contact us to help get you set up properly.

Contact Support:

Web link: <https://qualitywatertreatment.com/support>

Web link QR Scan Code:



Email Address: Help@QualityWaterTreatment.com

Email Address QR Scan Code:



ITEMS INCLUDED

- 1) SoftPro Control Valve (packed inside the brine tank)
- 2) Mineral Tank with Preloaded Media and Pre-installed Distributor Tube
- 3) Neoprene Tank Jacket
- 4) Brine Tank Assembly
- 5) Optional - Quick-Connect Kit / Hoses
- 6) Optional - Whole House Carbon Filter. If purchased, the Whole House Carbon Filter, the following will be included:
 - a) Carbon Filter Tank (**ATTENTION:** The tank comes pre-loaded with carbon media.)
 - b) Neoprene Jacket
 - c) Up-flow Head
 - d) Upper Basket
 - e) Bypass Valve
 - f) 1" Connectors (qty. 2)

7) Optional - Chlorine Removal KDF-55.

- a) If purchased, the Chlorine Removal KDF-55 will be pre-installed inside the mineral tank.

NOTE: Small parts are placed in the small parts bag inside the brine tank. Please keep in the bag until ready to install. (Let's not lose them... 😊)

NOTE: Pre-Loaded Mineral Tanks

- Up to 64,000 Grain Capacity Tanks:
 - Your new SoftPro Water Softener tank is already fully loaded with the appropriate amount of resin up to 64,000-grain capacity.
- 80,000 Grain Capacity Tanks and larger
 - 80,000-grain capacity and larger softener will come partially loaded and include additional resin that you will add to the tank.

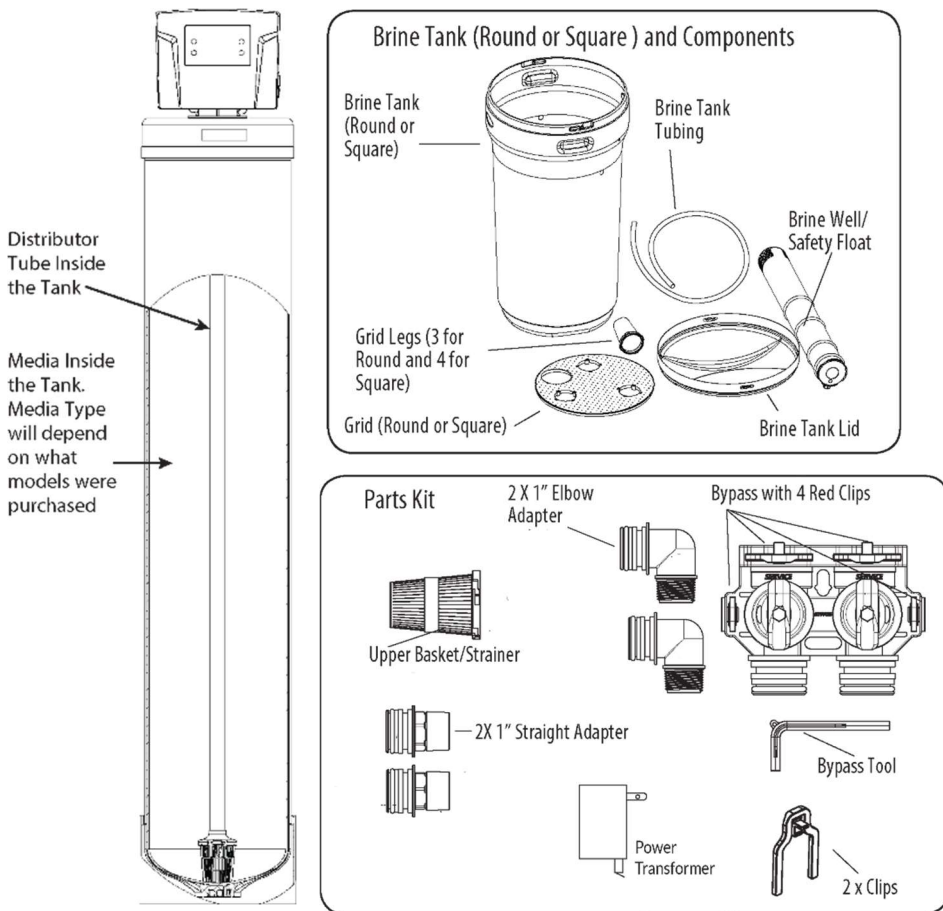

Optional - Whole House Carbon Filter below:

Tank with
Media loaded

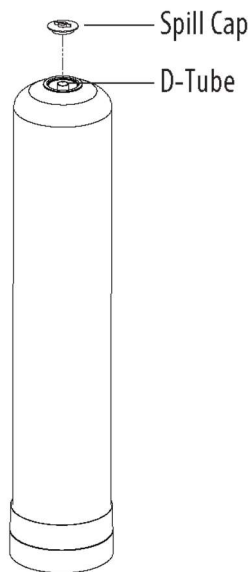

REMOVAL OF OLD WATER SOFTENER SYSTEM

If applicable, the following guide is typical of how many common water softeners are removed. If you find that your existing setup is unconventional, please take pictures and videos to send to our support team to review.

Follow the below steps:

- 1) Disconnect power. Unplug the power supply to your existing water softener.



- 2) Shut-off the main water supply.

Close the water main shut-off valve to the home. It is usually located in the front of the property. Alternatively, if you have a shut-off valve as water enters home (usually a ball or gate valve in the front of the building), then you can also shut-it off there.

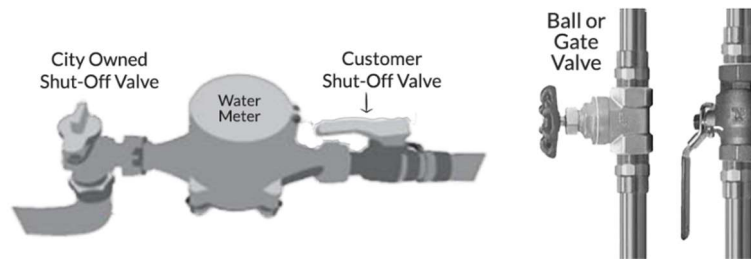

- 3)** Open the nearest cold-water faucet to help empty the remaining water in the pipes.

We do not want a flood. **Helpful tip:** Open a cold-water faucet in the home, removing a shower head because it is up high will create a good vacuum so pipes can drain faster and better.



- 4)** Set the bypass valve to the bypass position.

Bypass valve models vary by manufacturer (examples below). The bypass valve is located at the rear of the water softener control valve. It is where the pipe (copper/ PEX or PVC) connects to the water softener pipe. If the bypass valve includes the inlet and outlet valves, then close both the inlet and outlet valves. If the bypass valve has one stem, close the plunger into the stem or pull handle as shown in the first image.



- 5)** Reclaim salt or potassium chloride.

Remove any good salt or potassium chloride that you would like to keep and reuse from your old unit. Discard any clumps.

Disposal: Dispose unusable salt or potassium chloride properly into the garbage. Do not dispose onto lawns, gardens, plants or trees.



6) Disconnect inlet and outlet lines.

Remove the holding clips at the water softener inlet and outlet. Disconnect the water softener from the water pipes.

If there are no clips, then cut the water line pipe as it enters the water softener. Use the appropriate cutting tool for the different types of pipes (copper, PVC, PEX, CPVC, etc.)



7) Disconnect brine line.

Disconnect the brine line from the side of the softener valve.

8) Remove the old brine tank and mineral tank. Dispose properly.

9) Clear and clean the area for your new SoftPro Water Softener System.



You are now ready to install your new SoftPro Water Softener System.

INSTALLING YOUR NEW WATER SOFTENER

Installing your new SoftPro Water Softener is straightforward. The following step-by-step guide accompanied by our install videos (QualityWaterTreatment.com/Install), will get your new system up and running for you to enjoy fantastic soft water.

NOTE: Tanks are Pre-Loaded

- Up to 64,000 Grain Capacity Tanks:
 - Your new SoftPro Water Softener tank is already fully loaded with the appropriate amount of resin up to 64,000-grain capacity.
- 80,000 Grain Capacity Tanks and larger
 - 80,000-grain capacity and larger softeners will come partially loaded and include additional resin that you will add to the tank.

STEP-BY-STEP INSTALL VIDEO



We highly recommend that everyone refer to our install videos. Makes it easy and fast!

You can access step-by-step install video at the link QualityWaterTreatment.com/Install

OR

You can scan the below QR code to get direct access to our install videos by simply using your smartphone camera:



GENERAL WATER SOFTENER SETUP OVERVIEW

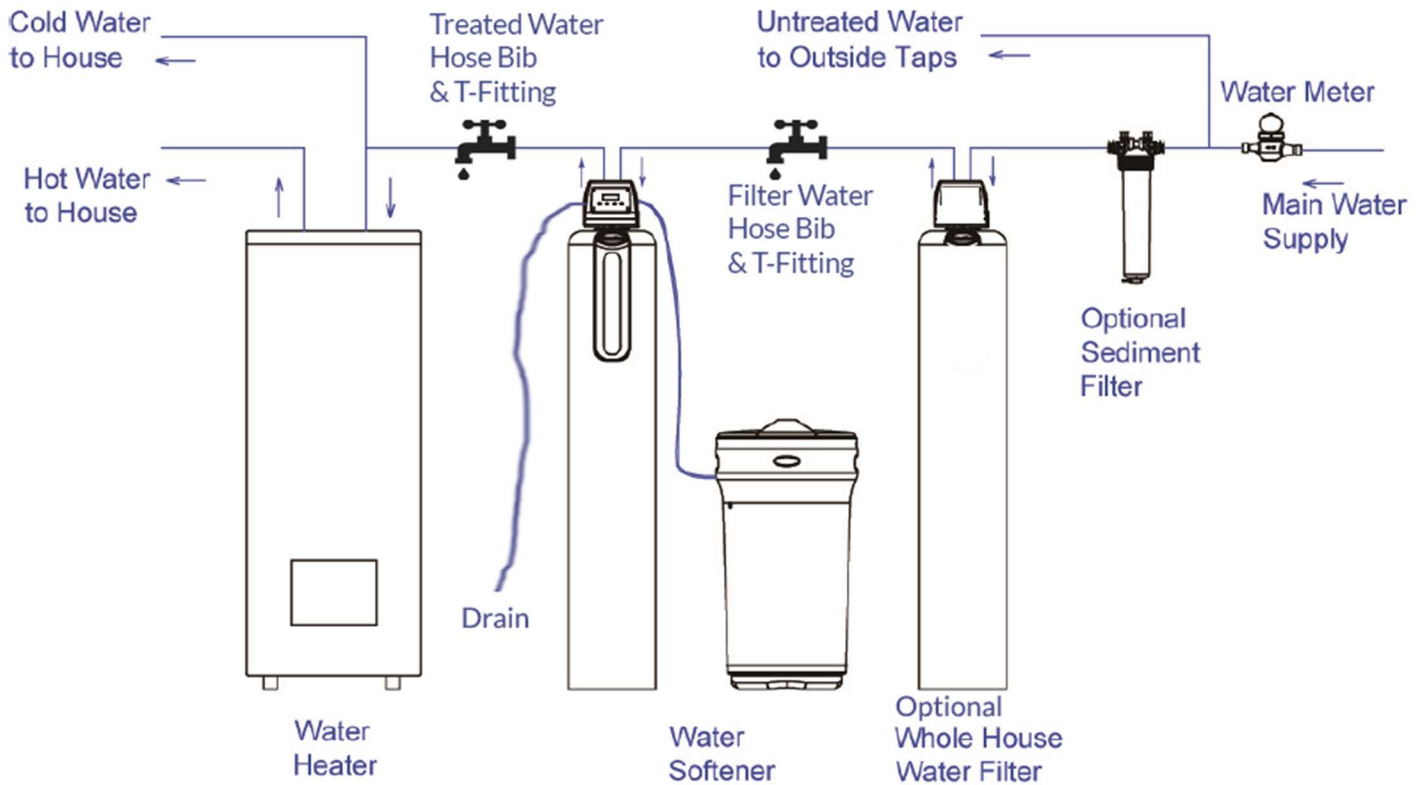

ASSEMBLE YOUR WATER SOFTENER SYSTEM

1) Setup your brine tank

- a) Remove the grid plate and legs from the brine tank and snap the legs into the bottom of the grid plate. You will hear a “click” sound after securing each leg.

ATTENTION: If the plastic tabs are still on the outer sides of the grid plate you will want to break them off.

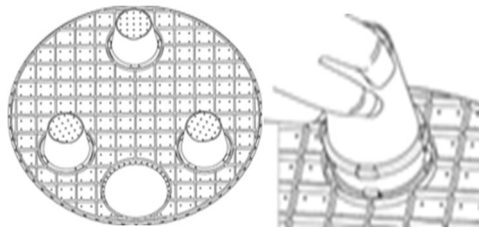

- b) Place the grid plate with legs facing downward into the bottom of the brine tank and push down firmly.

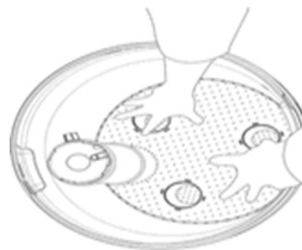

- i. Align the brine well cylinder to the small brine line hole near the top of the brine tank. (This is where the brine line will slip through.)

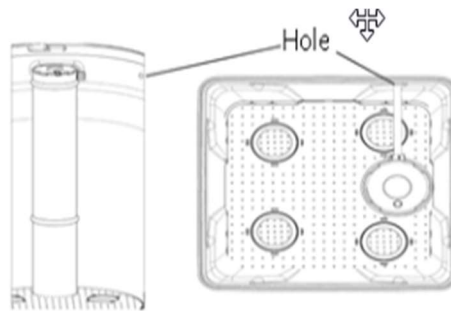

- c) Insert the brine well with float into the large hole on the grid plate (round or rectangle).

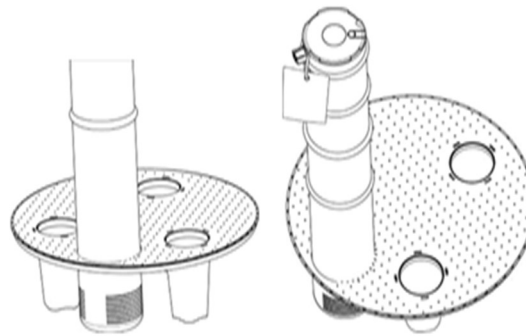

- d) Connect the brine line to the float in the brine well cylinder.
 - i. Run the brine line tubing through the small hole near top of the brine tank.
 - ii. Attach the plastic nut and insert the plastic sleeve into the tubing end.

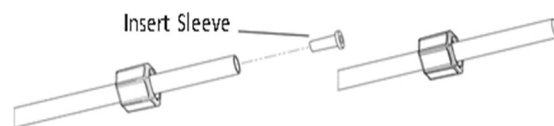

- iii. Only hand tighten the brine line nut to the float assembly.

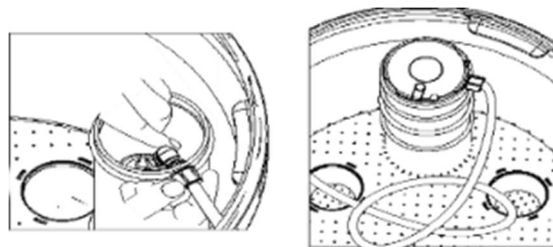



The brine tank setup is complete.

OPTIONAL WHOLE HOUSE FILTER

2) Setup the optional Whole House Filter. (*If not purchased, skip to the next step.)

ATTENTION: The Whole House Carbon Filter is pre-loaded with carbon media.

a) Install the neoprene jacket

Wrap the black neoprene jacket around the carbon filter tank. Zip it up and pull the bottom of the jacket down to remove wrinkles.



b) Remove the protective cap from the top of the carbon filter tank

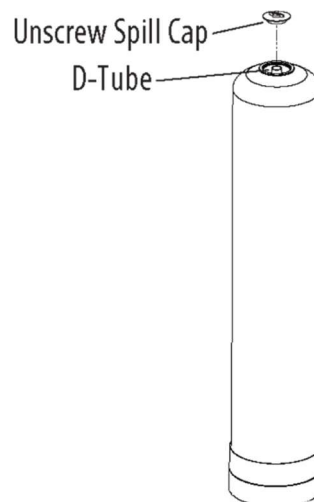

- c) Install the upper basket to the up-flow head.



- d) Lower up flow head with upper basket attached over the distributor tube located in the carbon filter tank. Only hand tighten the head onto the tank.

ATTENTION: Do not use lubricants or Teflon tape.



- e) Install the bypass valve to the up-flow head.



- f) Attach the two connection fittings onto the bypass valve.



ATTENTION: At a latter step, after the water softener is set up, then plumb the OUTLET side of the carbon filter to the INLET side of the water softener valve. This will be instructed later.

The whole house carbon filter setup is complete.

3) Install the neoprene jacket on the mineral tank.

Wrap the black neoprene jacket around the carbon filter tank. Zip it up and pull the bottom of the jacket down to remove wrinkles.



4) Unscrew media spill cap from the top of the mineral tank.

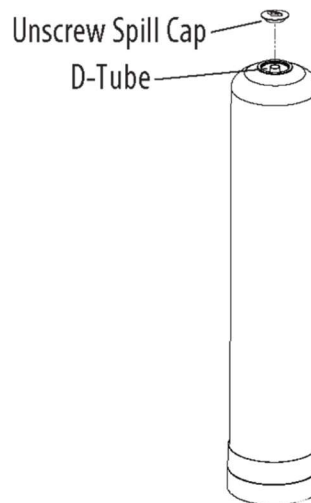

5) Attach upper basket to bottom of control valve by twisting into place, gently pull on basket to make sure it is secure.



6) Add additional resin media, if required*. (Applies only to 80k or larger, otherwise skip to the next step.)

*If over an 80,000 or larger grain capacity softener, then add the appropriate media/ resin that was supplied to the top of the mineral tank.

NOTE: Systems from 24,000 through 64,000 grain capacity are pre-loaded with the proper amount of resin.

Only the 80,000 or larger grain capacity water softener will come with additional resin to load into the mineral tank.

- a) Cover the opening of the distributor riser tube (located at the top of the mineral tank) with a cap, plastic bag or tape.
- b) Pour all the resin media that was provided to you into the mineral tank.
- c) Uncover the distributor tube.
- d) Clean off the interior tank threads with water to remove any resin.

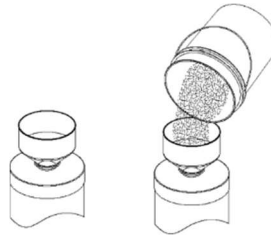

7) Attach the control valve to the mineral tank.

- a) Place the valve onto the top of the mineral tank.
- b) Guide the bottom of the basket to insert the distributor riser tube ("D-Tube" or Riser Tube) that is located inside the tank.



- c) Carefully screw the control valve onto the mineral tank. Hand tighten ONLY. (The “O” ring of the control valve will seal the tank.)

WARNING: Be careful not to cross-thread the valve. The valve should screw on easily. Hand tighten ONLY.

WARNING: Be careful not to pinch or wind the electrical cord in the threads/ valve and tank connection.



- 8) Install the bypass valve to the control valve.

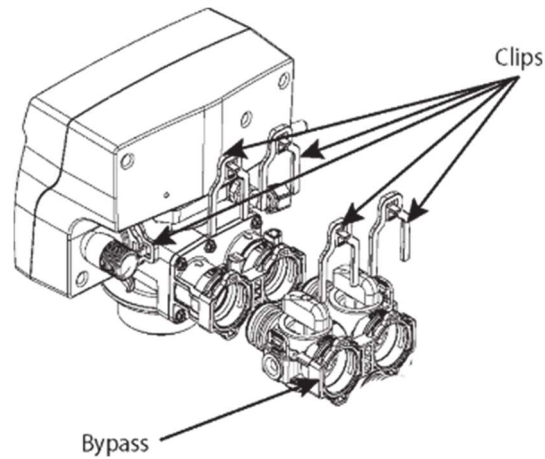

- a) Remove the two red clips from the rear of the SoftPro control valve.
- b) Press the bypass valve into the rear of the SoftPro control valve.



- c) Reinstall the red clips. Gently tug on the clips to make sure they are locked into place.



- 9) Connect the brine line to the control valve.
 - a) Insert the plastic sleeve (this can be found on the thin wire holding the vanilla tag on the brine line elbow). Only hand tighten the brine line nut to the elbow fitting.

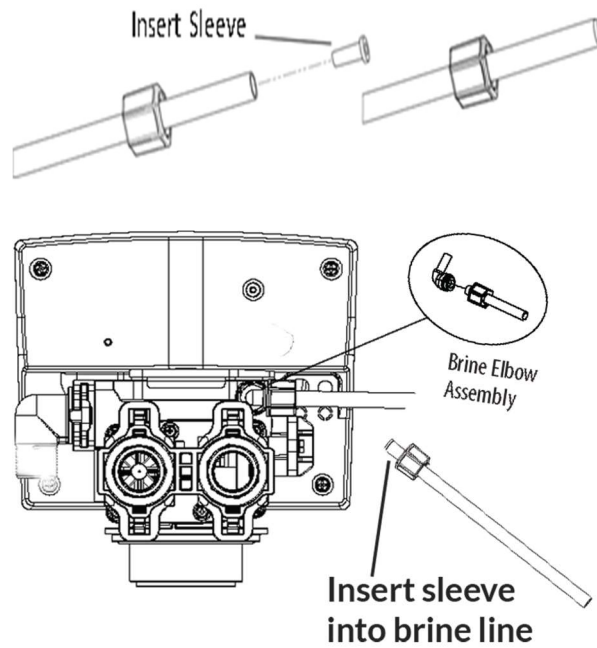

10) Connect the drain line to the control valve.

WARNING: Do not remove the drain line elbow or fitting from the rear of the control valve. (This fitting includes the drain line flow control. If removed, the system will not work properly, and the resin will drain out when the system regenerates.)

WARNING: Do not install the drain line more than 3 feet above the control valve.

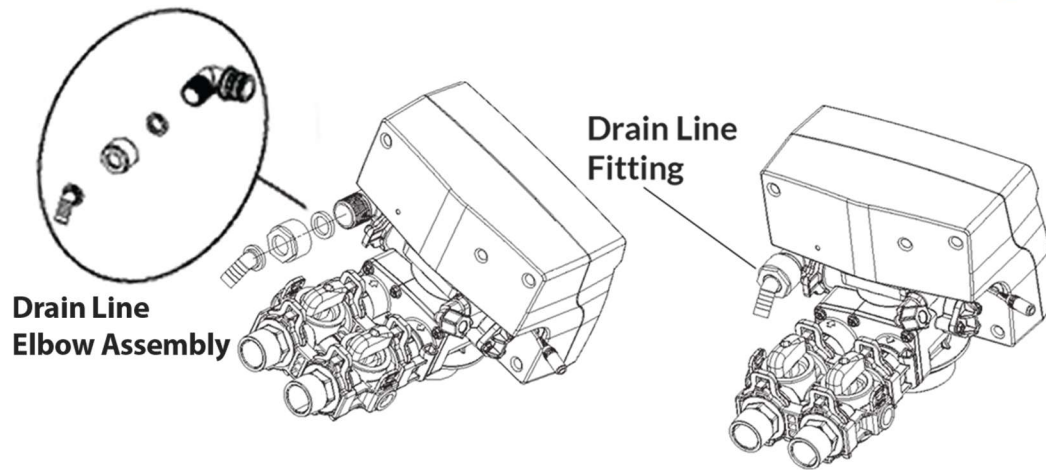

- a) Slip the vinyl tubing ($\frac{1}{2}$ " ID) to the rear of the control valve.
- b) Secure with a hose clamp.
- c) Run the drain line to an appropriate drain area.

DRAIN INFORMATION

ATTENTION: Waste connections or drain outlet shall be designed and constructed to provide for connection to the sanitary waste system through an airgap of 2 pipe diameters or 1 inch (22 mm) whichever is larger.

Never insert drain line directly into a drain, sewer line, or trap. Always allow an air gap between the drain line and the wastewater to prevent the possibility of sewage being back-siphoned into the conditioner.

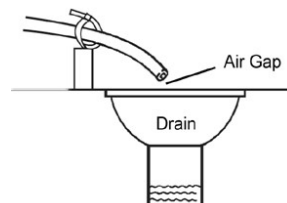

Common drains include flow drain and washing machine drains. The drain will need an air gap or open space to breathe to prevent the water from backing up. Or a pre-looped line with a drain line shown in photo below will already have an airgap where the plumber ran it to.

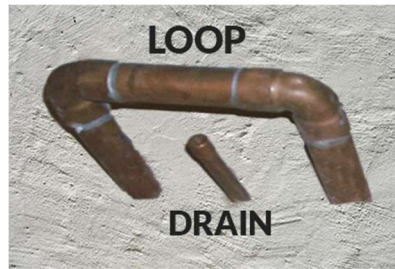

If draining to a closed sewer line, then install a P-Trap with a riser.

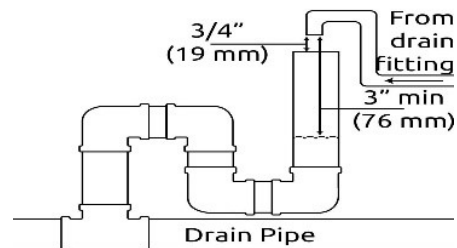

Rigid Drain Line Pipe Option:

To use a rigid pipe (PVC, CPVC etc.), attach the rigid pipe to the open end of the vinyl tubing.

ATTENTION: Vinyl tubing must be connected to the control valve, and then the rigid pipe can be connected to the open end of the vinyl tubing using a ½" NPT to hose barb fitting.

Additional parts needed:

- ½" Hose Barb by ½" Female NPT fitting
- ½" Hose clamp
- ½" PVC Male adapter
- Appropriate rigid pipe and fittings.



11) Shut-off the main water supply.

Close the water main shut-off valve to the home (if not yet closed). It is usually located in the front of the property. Alternatively, if you have a shut-off valve as water enters home (usually a ball or gate valve in the front of the building), then you can also shut-it off there.

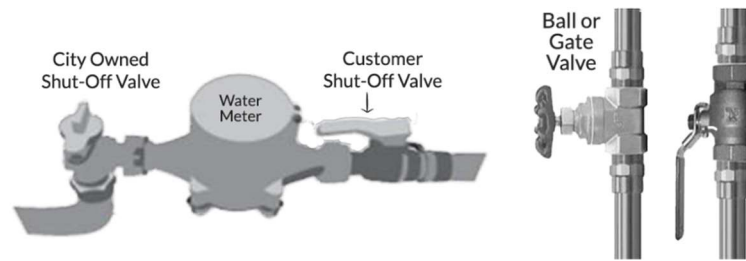

- a) Verify and label the water supply and feed lines for the water softener.
- i. **For Pre-Built Soft Water Loops:** If a water softener has never been installed, cut the water line softener loop. Use an appropriate pipe cutting tool.
 - ii. Place a bucket to catch the water. Then very slightly turn open the water main to identify which side is the water supply line. Label the water supply line inlet.
- b) **For Replacing an Existing Water Softener:** After removing the old water softener, place a bucket to catch the water.
- i. Then very slightly turn open the water main to identify which side is the water supply line. Label the water supply side.
- c) **If a soft water loop does not exist,** then you will need to install a loop from the main water supply line prior to entering your home or have a professional install one.

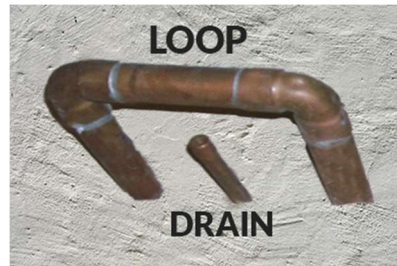

RECOMMENDED OPTION – INSTALL HOSE BIB FOR TREATED SOFT WATER ACCESS

Install an additional hose bib to access soft water conveniently.

A soft water hose bib located near the water softener can aid in convenient water testing and allow access to soft water (great for washing cars and windows, etc.)

12) Install a soft water hose bib.

- a) Install a "T" fitting and a hose bib to the plumbing line running into the home.

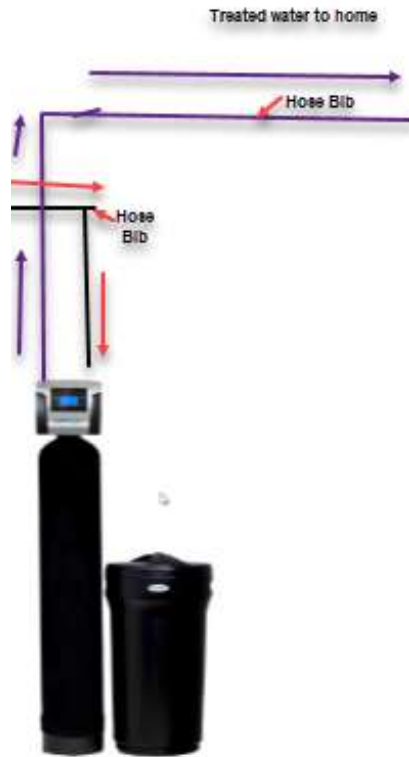

b) Verify that the water softener valve is in the bypass position.

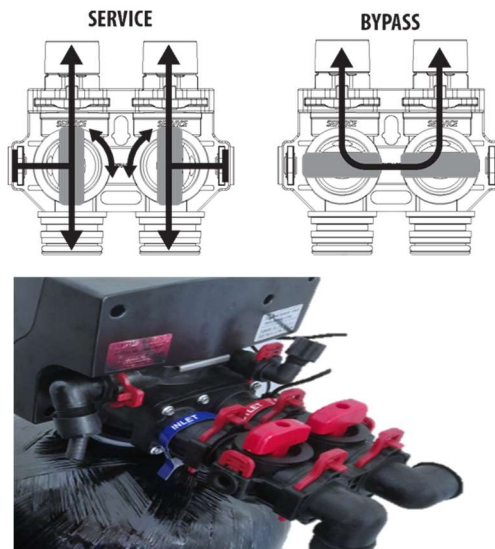

The optional treated soft water hose bib is complete.

13) Connect the plumbing to the valve.

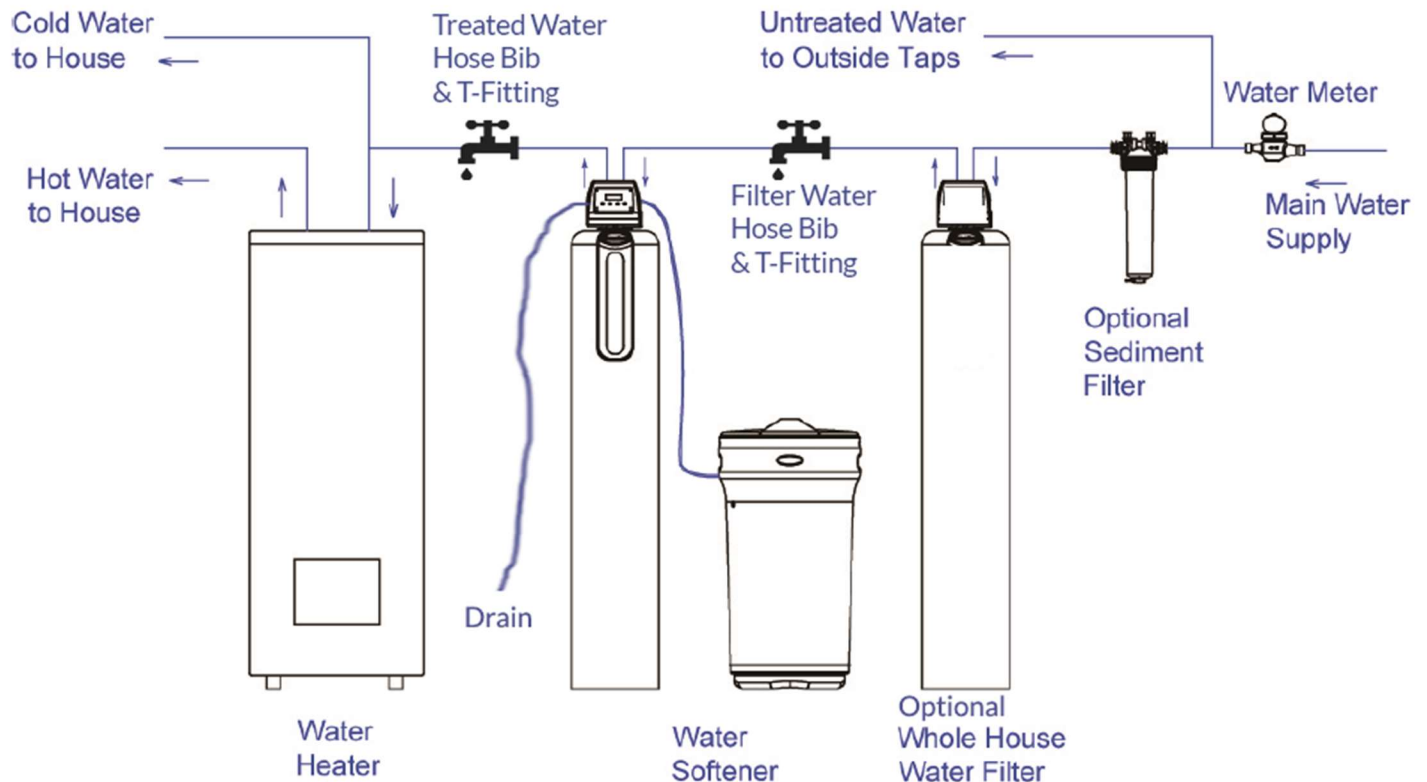

(Follow either (A) Quick-Connect Kit, or (B) Standard connection instructions below.

(A) QUICK-CONNECT KIT INSTALL

If using the optional quick-connect kit/ hoses*, follow below.

- a) Connect the quick connect hoses to your plumbing pipes.
- b) Remove the two red clips from the bypass valve.
- c) Bend the quick connect hose lines from the plumbing to align with the bypass valve.
- d) Attach the appropriate water lines to appropriate sides of the bypass valve.
 - i. The water supply line connects to the INLET side of the softener valve.
 - a. **NOTE:** For optional whole house filter, connect to the INLET side of the filter valve (not the softener valve).
 - ii. The treated soft water line connects to the OUTLET side of the softener bypass valve.
 - iii. Directly push the quick-connect hose ends into the bypass valve.
- e) **For the optional Whole House Filter Installation, if applicable,** complete the filter connection to the water softener. (Skip to the next step if not applicable.)
 - i. If using Quick-Connect hose, then connect

- ii. Plumb the filter OUTLET side to the water softener INLET side.
 - 1. Use optional Quick-Connect hose. (Filter hose bib is not required.)
 - 2. If optional Quick-Connect hose is not provided, then plumb a hose bib with “T” fitting in between the line from the filter and softener valves.
- iii. Verify that the filter bypass valve is in the bypass position.
- f) Reinstall the red clips to secure the fittings. Gently tug on the clips to make sure they are locked into place



(B) STANDARD PLUMBING CONNECTION TO THE BYPASS VALVE

(If optional Quick-Connect Kit was not provided.)

- a) Wrap Teflon tape onto both elbow fittings.

WARNING: USE ONLY TEFLON TAPE. Do not use pipe dope or plumbers' putty. This can damage the plastic fittings.



- b) Install the two elbow fittings into the bypass valve.
- c) Remove the two red clips from the bypass valve.
- d) Push both elbow fittings into the bypass valve.
- e) Slightly turn the fittings in place.
- f) Reinstall the red clips to secure the fittings. Gently tug on the clips to make sure they are locked into place.



- g) For the optional Whole House Filter Installation, if applicable**, complete the filter connection to the water softener. (Skip to the next step if not applicable.)
- i. Plumb the filter OUTLET side to the water softener INLET side.
 1. Plumb a hose bib with "T" fitting in between the line from the filter and softener valves.
 - ii. Verify that the filter bypass valve is in the bypass position.
- e)** Plumb the appropriate water lines to appropriate sides of the bypass valve.
- iv. The water supply line connects to the INLET side of the softener valve.
 - a. **NOTE:** For optional whole house filter, connect to the INLET side of the filter valve (not the softener valve).
 - v. The treated soft water line connects to the OUTLET side of the softener bypass valve.

The softener system plumbing is now complete.

- 14) Turning the water back on.**
- a) SLOWLY turn on your water main.
 - b) Turn on a faucet in the home or attach a garden hose to the soft water hose bib and turn it on (recommended)
 - c) Run the water until it shows clear.
 - i. Use a container to view the water clarity. (This is to remove air and any plumbing debris before entering the softener system. Let the water run until the water shows clear in the container.)
 - ii. Once the water runs clear into the container, turn off the faucet.

- 15)** For Whole House Filter Installation, see below for initially cleaning the filter tank. (Skip to the next step if not applicable.)
- SLOWLY turn open the INLET side of the carbon filter bypass valve (opens clockwise) until the carbon filter tank fills with water. Once the tank is full, the water will stop running.
 - SLOWLY turn open the OUTLET side of the filter bypass valve (opens counter-clockwise).
 - Connect a hose to the bleed hose bib and run to a container or bucket.
 - Slowly open the bleed valve and let the water run.
 - Run the water until it shows clear.
 - Use a container to view the water clarity. (This is to remove any media dust, air and any plumbing debris before entering the softener system. Let the water run until the water shows clear in the container.)
 - Once the water runs clear into the container, turn off the bleed hose bib.

ATTENTION: Check the water inside of the container for clarity.

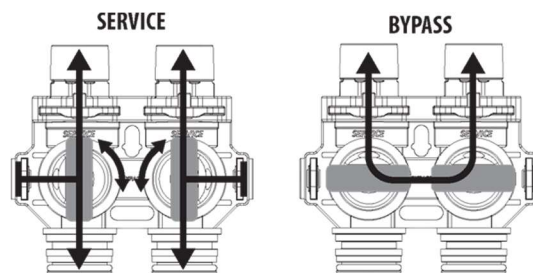

- 16)** Initial cleaning of the softener mineral tank.
- SLOWLY turn open the INLET side of the softener bypass valve (opens clockwise) until the mineral tank fills with water.
 - Once the tank is full, the water will stop running.
 - SLOWLY turn open the OUTLET side of the softener bypass valve (opens counter-clockwise).
 - Open the nearest softened treated cold-water faucet or hose bib and run the water until it shows clear.
 - Use a container to view the water clarity. (This is to bleed out the resin's colour and air. Let the water run until the water shows clear in the container. Once the water runs clear into the container, turn off the faucet. Your new softener is ready.)
 - Once the water runs clear into the container, turn off the faucet or hose bib.

ATTENTION: Check the water inside of the container for clarity.

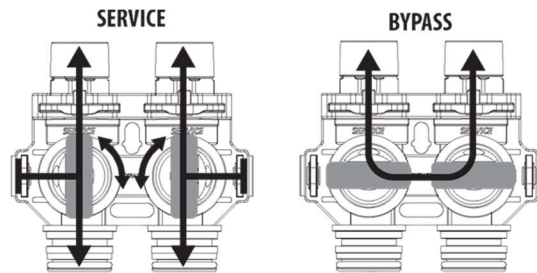

NOTE: Manual regeneration is NOT required. Resin media has been previously pre-charged and ready for use.

17) Add 2 gallons of water to the brine tank.

18) Add salt to the brine tank.

- a. Add two 40 lbs bags of rock salt (80 lbs total). Pellets are preferred but extra coarse salt is acceptable.



19) Plug your control valve power supply into the electrical outlet.



Your new SoftPro Water Softener is complete and ready for programming.

PROGRAMMING YOUR VALVE

INITIATE THE PROGRAMMING SETTINGS

Press and hold down the **MENU** button until the [MENU] screen unlocks with a beep (about 3 seconds).

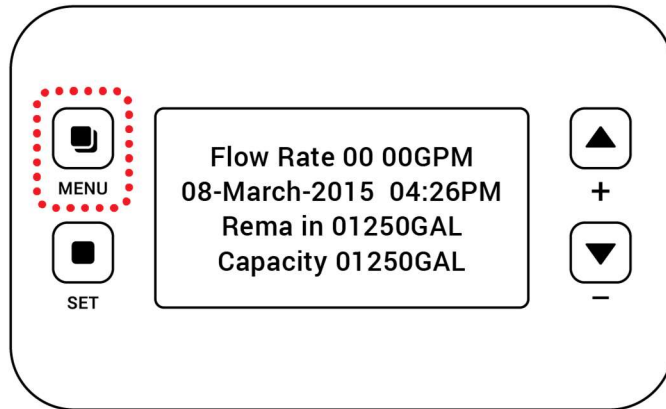

SET DATE AND TIME

1. Press **MENU** to display Date and Time settings. (If already highlighted, skip to next step.)

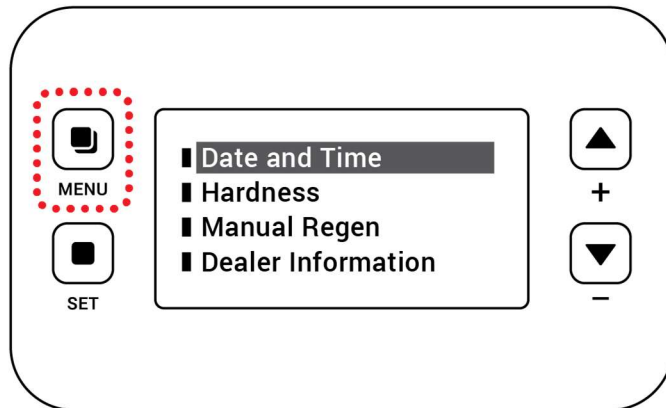

2. Press **SET** to enter the Date and time.

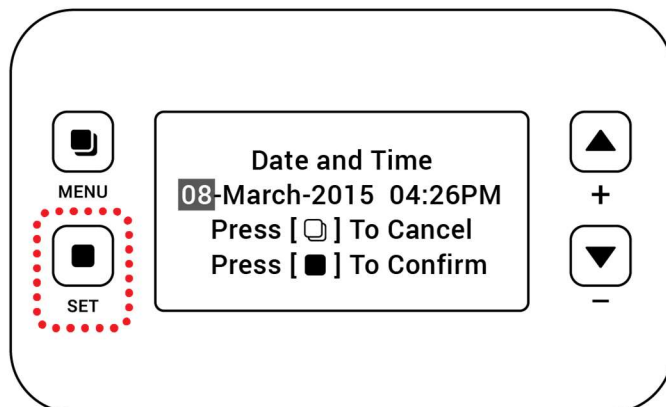

3. Use the **UP** and **DOWN** arrows to select the appropriate Date, Month, Year and Time.

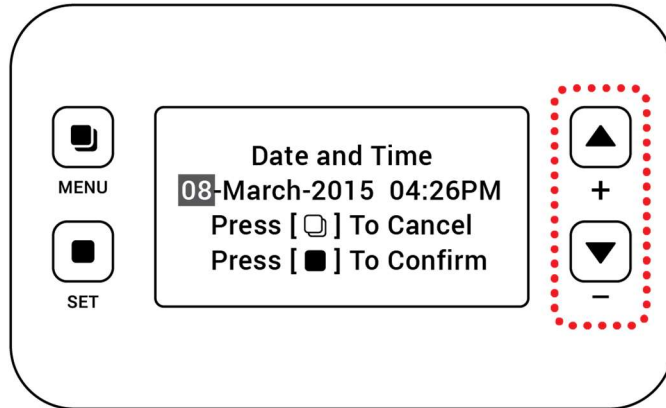

4. Press **SET** after each selection to move to the next field.

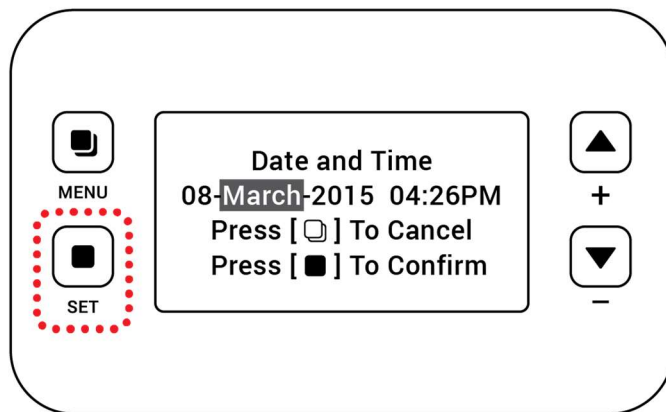

5. Once Date, Month, Year and Time is selected, press **SET** to complete the setting

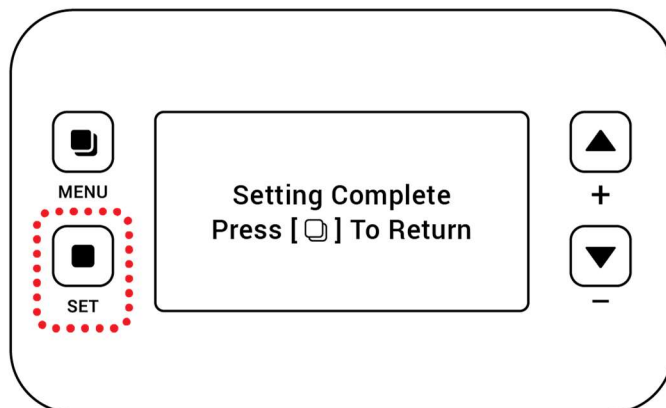

6. Press **MENU** to return to the home screen.

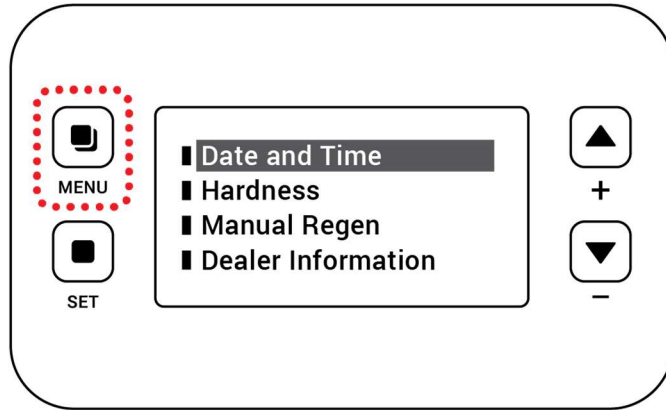

SET WATER HARDNESS

1. Press **MENU** to display the home screen

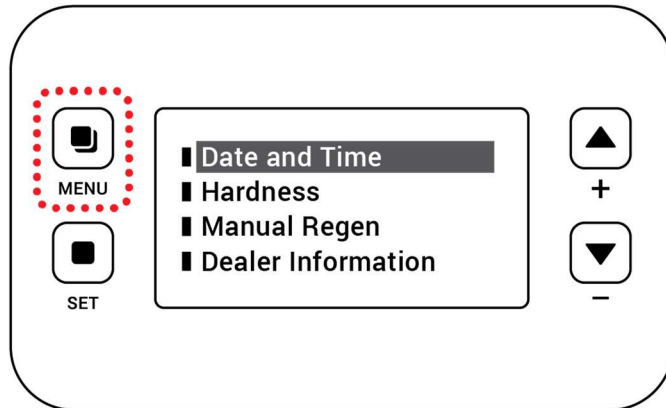

2. Select **DOWN** arrow to select Hardness setting

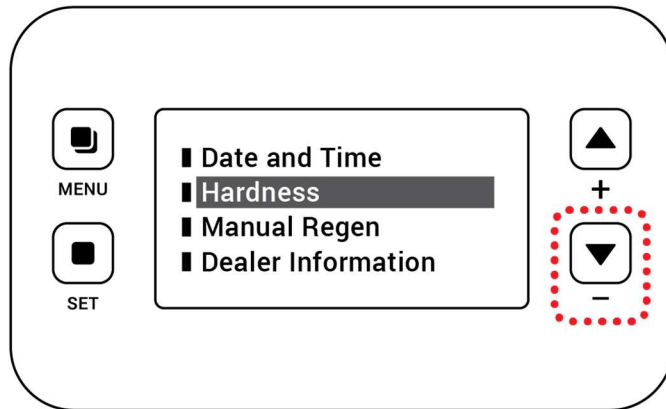

3. Press **SET** to input your water hardness. Input the water hardness in grains per gallon (GPG)* units.

*If your water hardness is in mg/L or PPM units, divide that number by 17.1 to convert to GPG units (round up to the nearest number if needed).

Notes on Iron Removal Application*: (If NOT using an iron filter, please see the following.)
If using your water softener to additionally remove iron from your water, then add 3 GPG's to your total water hardness when entering in the hardness setting.

*This is only applicable for iron levels equal to 2-3 ml/L or PPM.

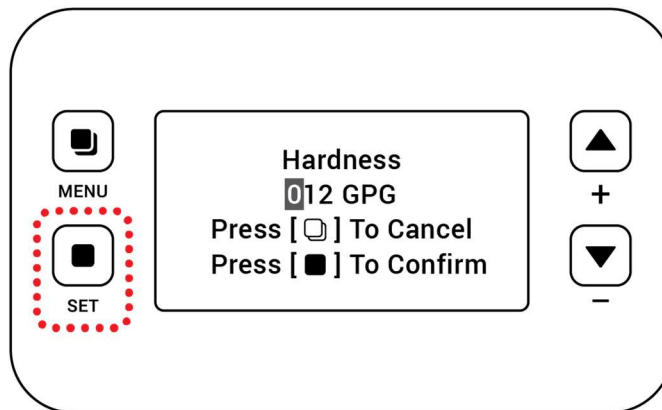

4. Press **SET** to select each field

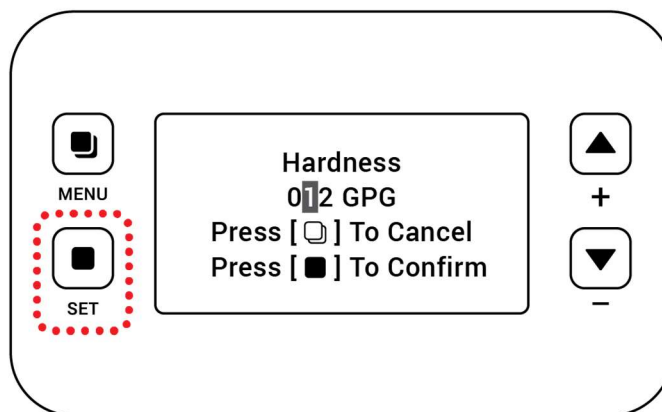

5. Use **UP** and **DOWN** arrows to select the appropriate hardness (GPG) levels.

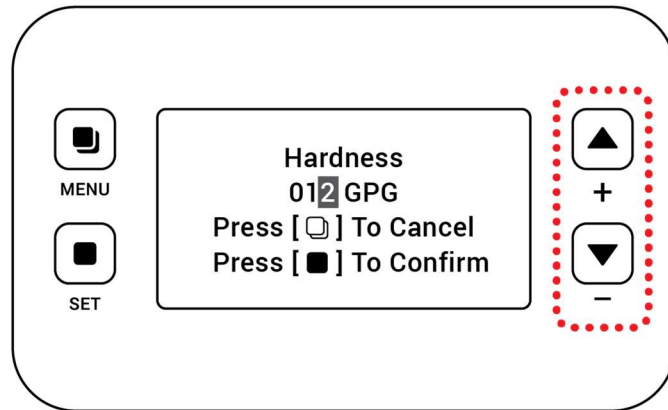

6. Press **SET** to complete the setting

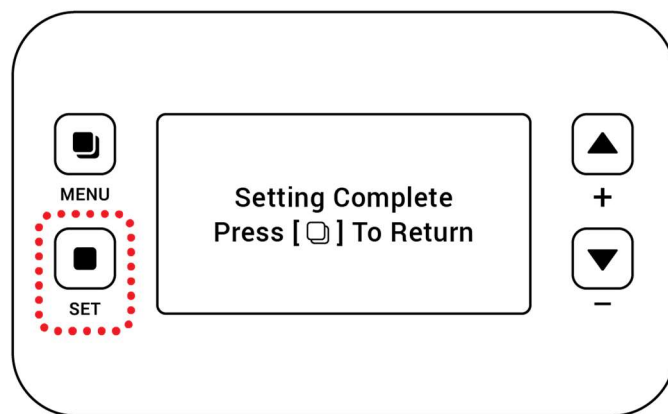

7. Press **MENU** to return to the home screen.

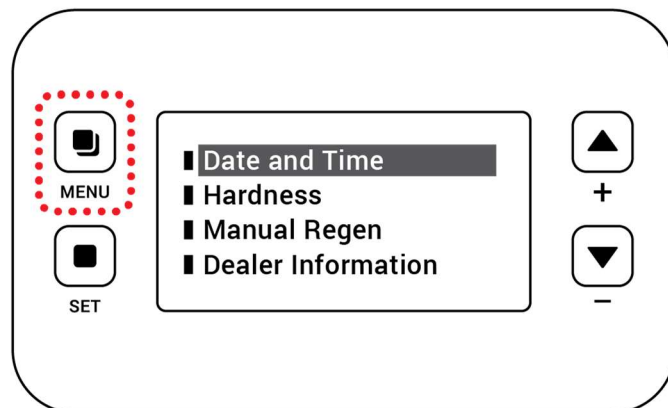

SET REFILL RATE

1. Press **MENU** to return to home screen

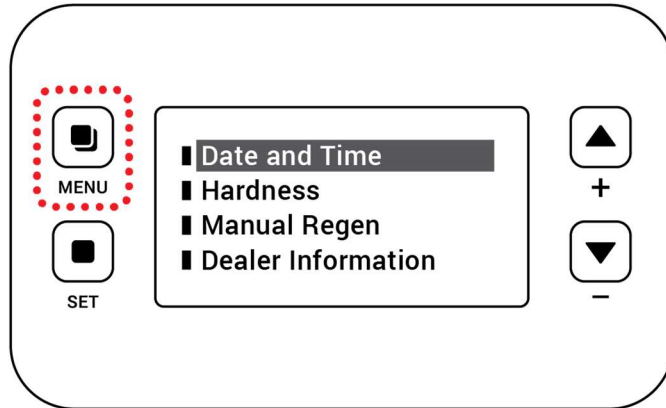

2. Press **DOWN** arrow until you get **Main Menu**

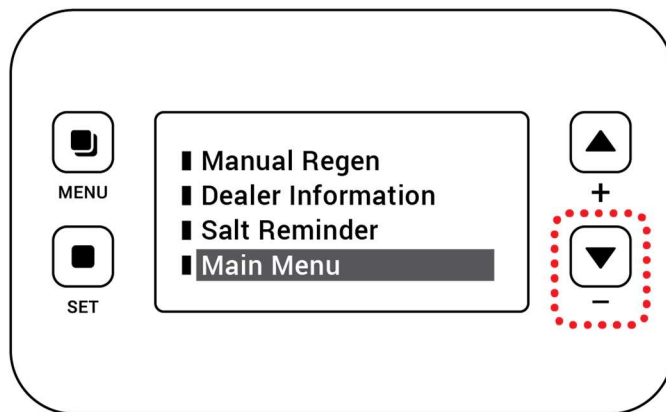

3. Press **SET**

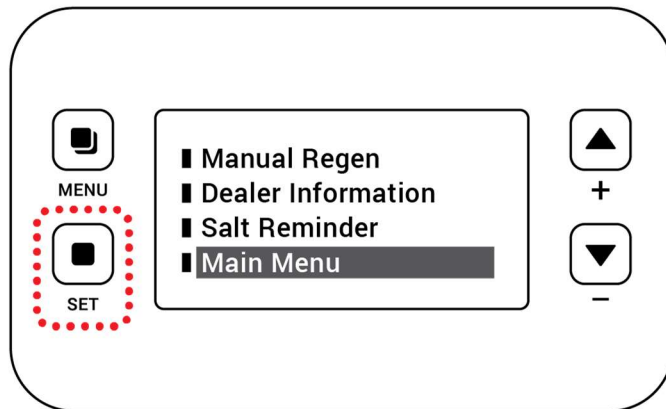

4. Press **DOWN** arrow until you get **Advanced Menu**

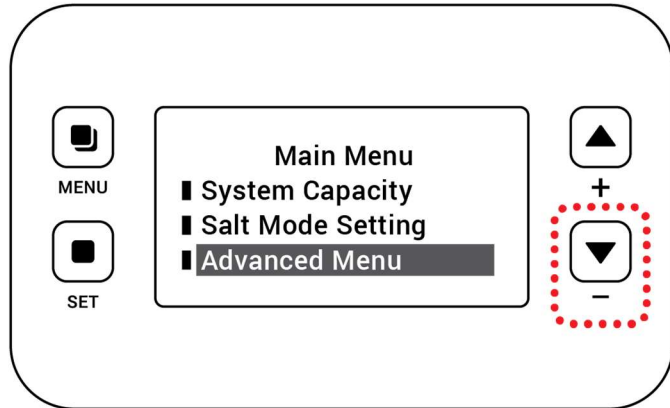

5. Press **SET** till it beeps

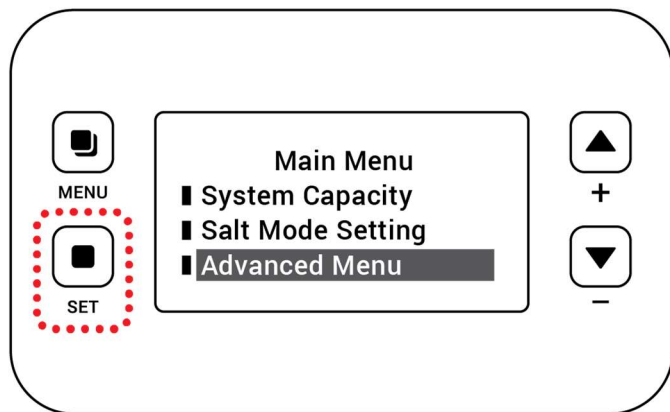

6. Press **DOWN** arrow to select **Refill Rate**

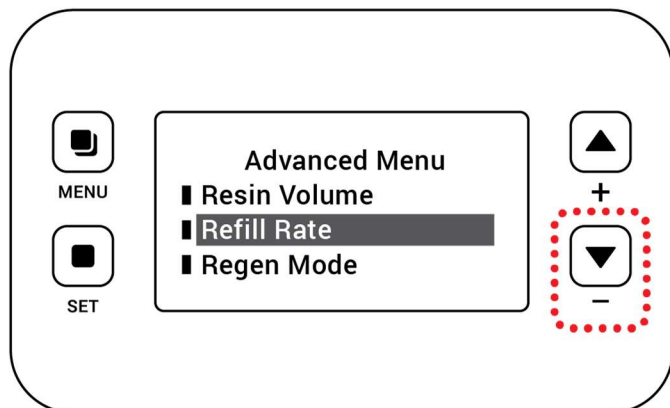

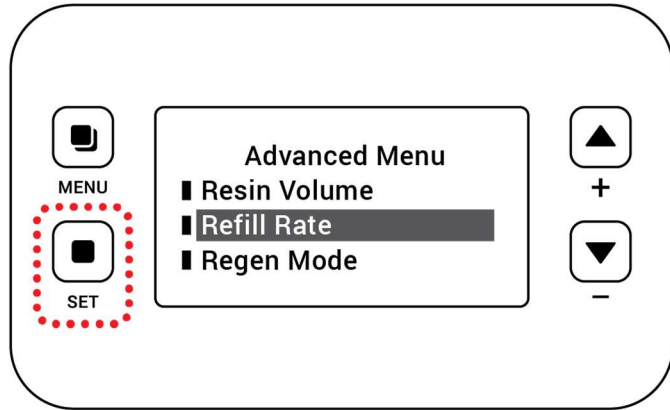
7. Press **SET**

ATTENTION: Make sure that the Refill rate is set to “0.2”, if not, set the Refill rate to “0.2”

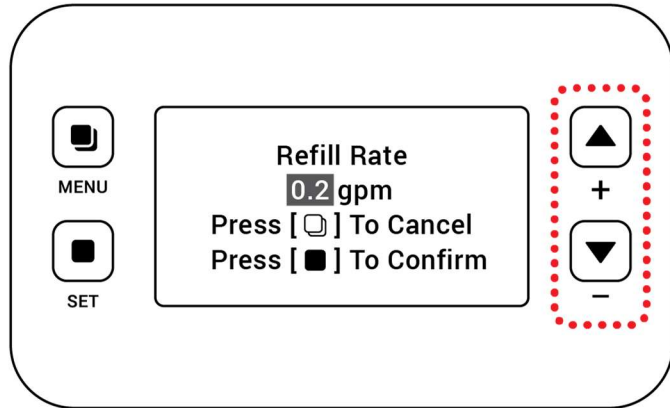
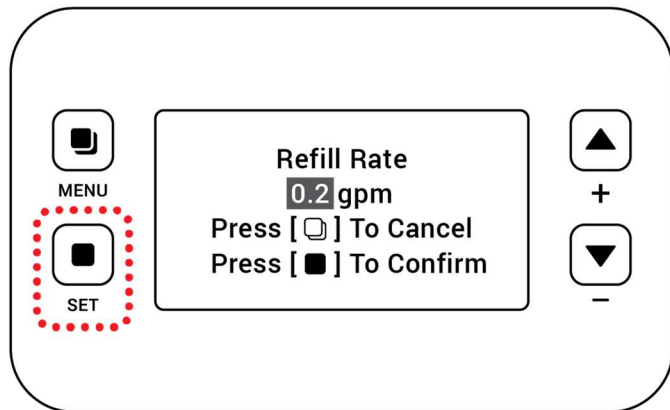
8. Use **UP** and **DOWN** arrow to set the Refill Rate to **0.2**9. Press **SET**

10. Press **MENU** to return

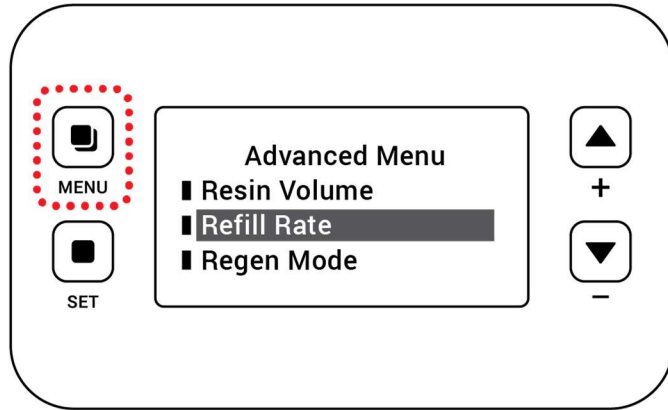

Set BW/Rinse Override

1. Press **MENU** to return to home screen

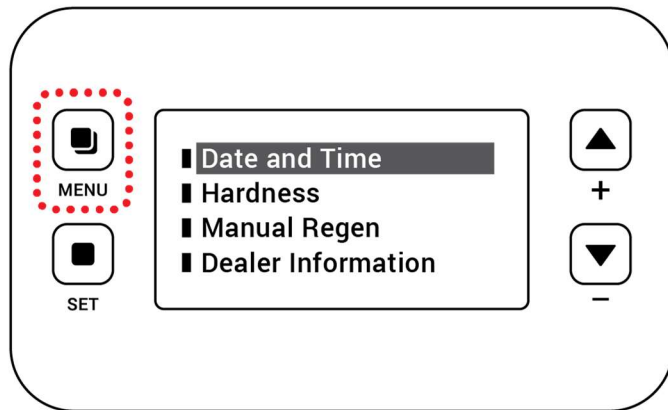

2. Press **DOWN** arrow until you get **Main Menu**

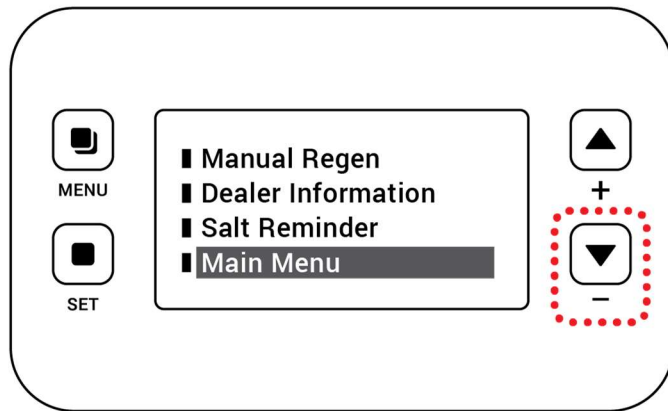

3. Press **SET**

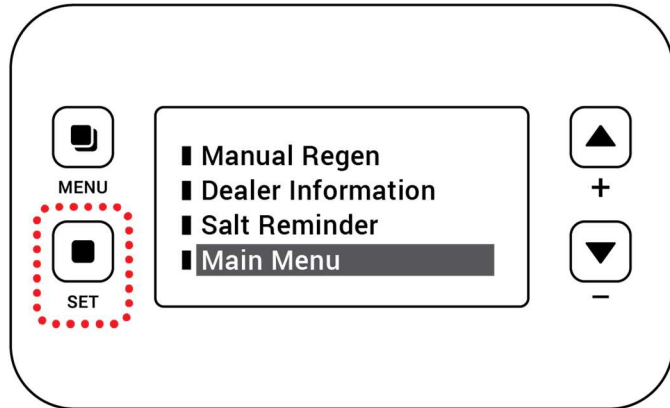

4. Press **DOWN** arrow until you get **Advanced Menu**

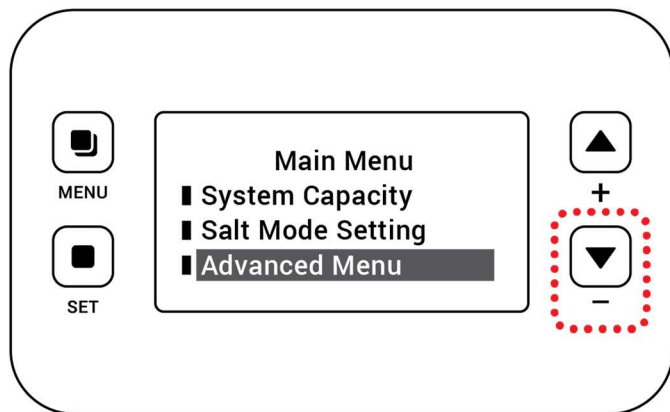

5. Press **SET** till it beeps

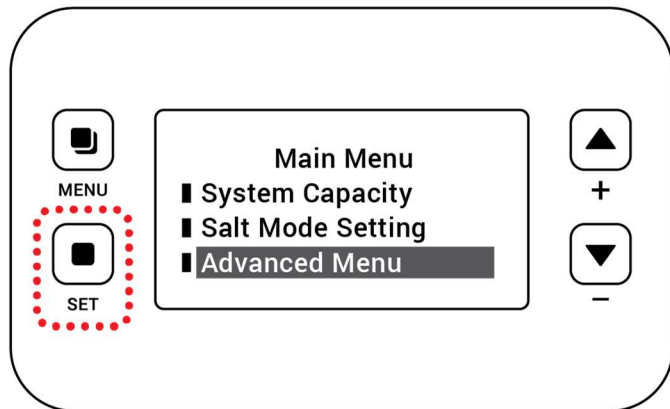

6. Press **DOWN** arrow until you get **BW/Rinse Override**

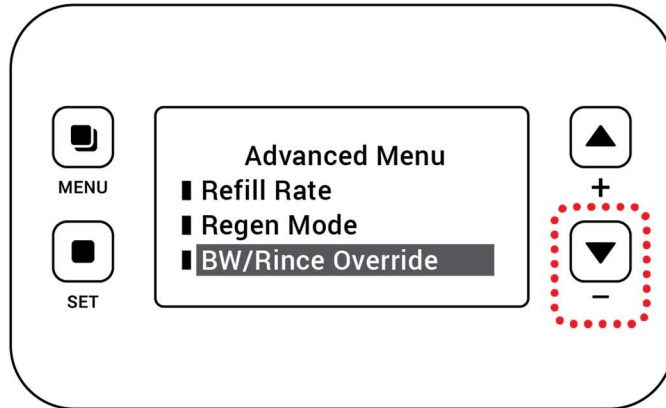

7. Press **SET**

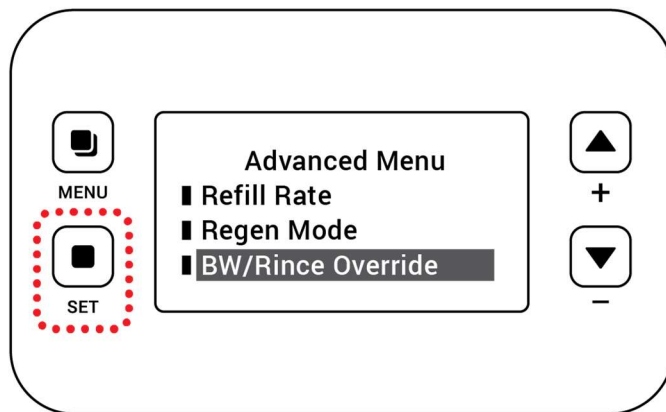

ATTENTION: Make sure BW/Rinse Override is set to **ON**

8. Use **UP** and **Down** arrow to set it to **ON**

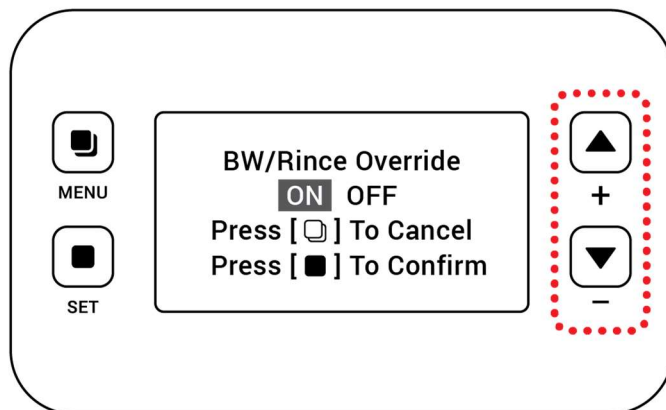

9. Once **ON** is highlighted, press **SET**

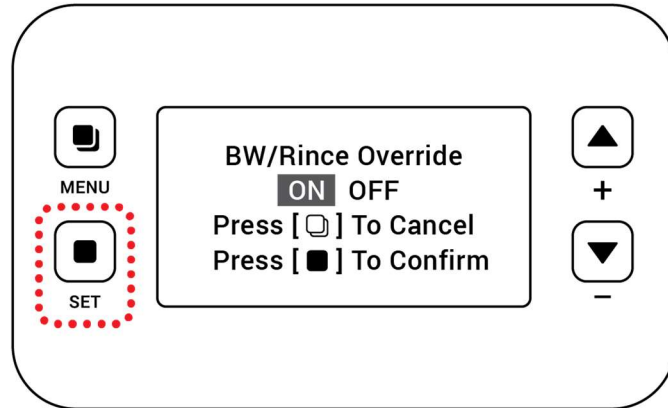

10. Once you SET to **ON**, Backwash is highlighted.

Press **SET**

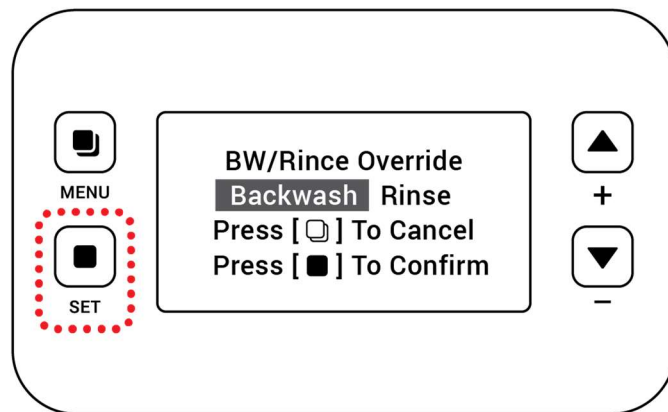

11. Set Backwash setting to 3 or 4 Regens not more than that, if it is so use **UP** and **DOWN** arrow to adjust

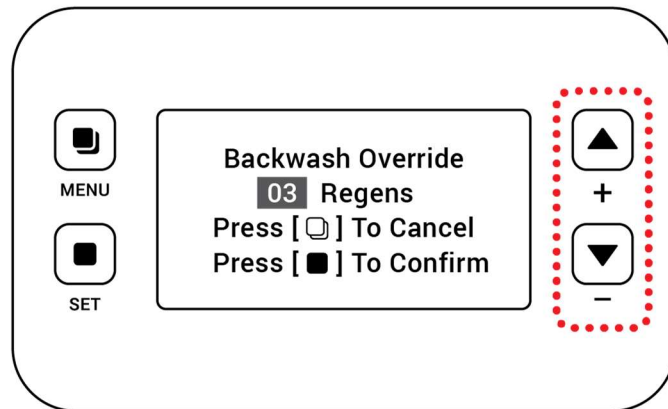

12. Press **SET**

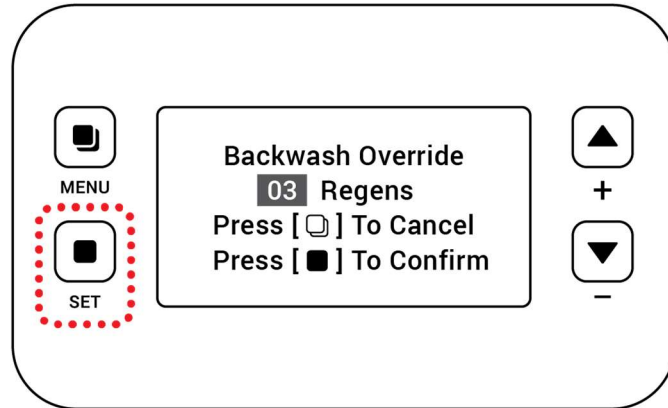

13. Press **MENU** to return

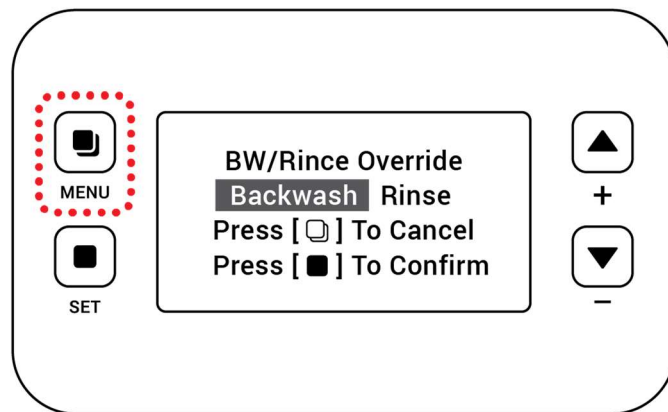

14. Use **DOWN** arrow to highlight **Rinse**

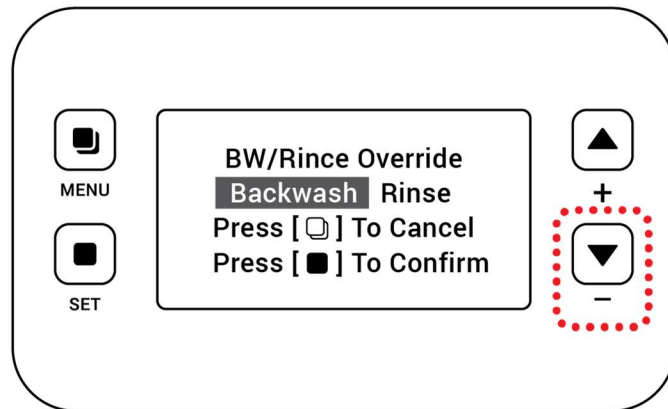

15. Once **Rinse** is highlighted, press **SET**

The screenshot shows a control panel with a central display. The display text reads: "BW/Rince Override", "Backwash Rinse", "Press [] To Cancel", and "Press [] To Confirm". The "Rinse" option is highlighted with a grey background. To the left of the display are two buttons labeled "MENU" and "SET". The "SET" button is circled with a red dotted line. To the right of the display are three buttons: an up arrow, a "+" sign, and a down arrow with a "-" sign below it.

ATTENTION: Make sure that **Rinse** is set to "00" or "01" not higher.

16. If Rinse is set to "00" or "01", Press **MENU** to return

The screenshot shows the same control panel. The display text now reads: "BW/Rince Override", "00 Regens", "Press [] To Cancel", and "Press [] To Confirm". The "00" value is highlighted with a grey background. The "MENU" button on the left is now circled with a red dotted line.

17. Press **MENU** until you are back on the main screen

The screenshot shows the main menu on the control panel. The display text reads: "Flow Rate 00 00GPM", "08-March-2015 04:26PM", "Rema in 01250GAL", and "Capacity 01250GAL". The "MENU" button on the left is circled with a red dotted line.

Programming of the SoftPro Elite Water Softener is complete.