

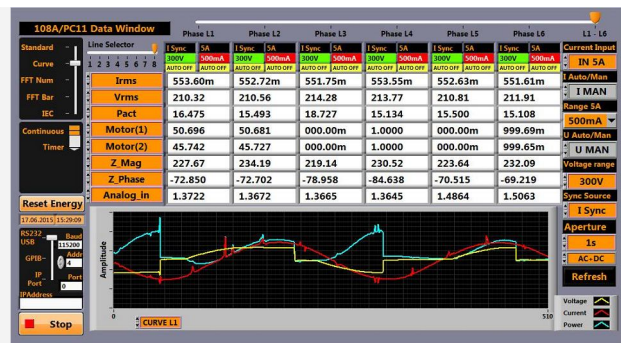

Electric Motor Testing Using Infratek 108A-6 High Precision Power Analyzer

The 108A-6 equipped with Option 03, (6 analog inputs, 2 digital inputs, and 12 outputs) performs all required measurements for motor testing.

Use the Infratek operating Software to perform motor tests in **STANDARD** measure mode. Values at different motor operating points can be stored and viewed when done.



108A Computer Software

The 108A scalable analog inputs can be used for torque-, temperature- and vibration measurements. Two scalable TTL-inputs are for speed- or torque measurement. An external synchronization input per phase from an encoder can be used to synchronize measurements to the pole position.

The 108A-6 measures two motors simultaneously: input power, output power, torque, slip, speed, and efficiency of every motor, as well as harmonics of current, voltage, power, impedance, and phase angle. For none sinusoidal signals (trapezoidal wave-forms or frequency inverters), we recommend to use the fundamental of impedance and fundamental of phase. From these values the motor inductances L , L_d , L_q and the motor resistances $R = R_m + R_{dc}$ can be determined.

The motor DC-resistance is obtained by applying a DC-current: $R_{dc} = P_{dc} / I_{dc}^2$. R_m is a magnetization dependent loss.

Standard	L1 5A As	L2 5A As	L3 5A As	L4 5A As	PAGE 1
Arms	553.70m	552.81m	552.08m	553.80m	IN 5A
Vrms	212.23	214.29	212.85	210.45	500mA
Watt	14.337	18.582	16.860	15.563	300V
M1 M2 M3	49.779	49.764	000.00m	0.0000	Sync A
M4 M5 M6	1.0000	000.00m	999.68m	0.0000	1s
Z01	259.68	256.69	245.08	249.63	WAVE
Phi01	-75.140	-79.689	-68.895	-72.537	Standard
A1 A2 A3	1.3664	1.3667	1.3668	0.0000	
HOLD	AC+DC	L3 - L6	FFT Table	Reset Wh	SETUP

108A Display Screen

The 108A display and the computer software screen can be configured to the user's needs.

- M1| M2| M3| = Input power, output power, torque
- M4| M5| M6| = Slip, rpm, efficiency
- Phi01 = Phase angle of fundamental
- A1| A2| A3| = Analog inputs 1, 2, 3

Efficiency Measurement of an Inverter driven Induction Motor in Steady State

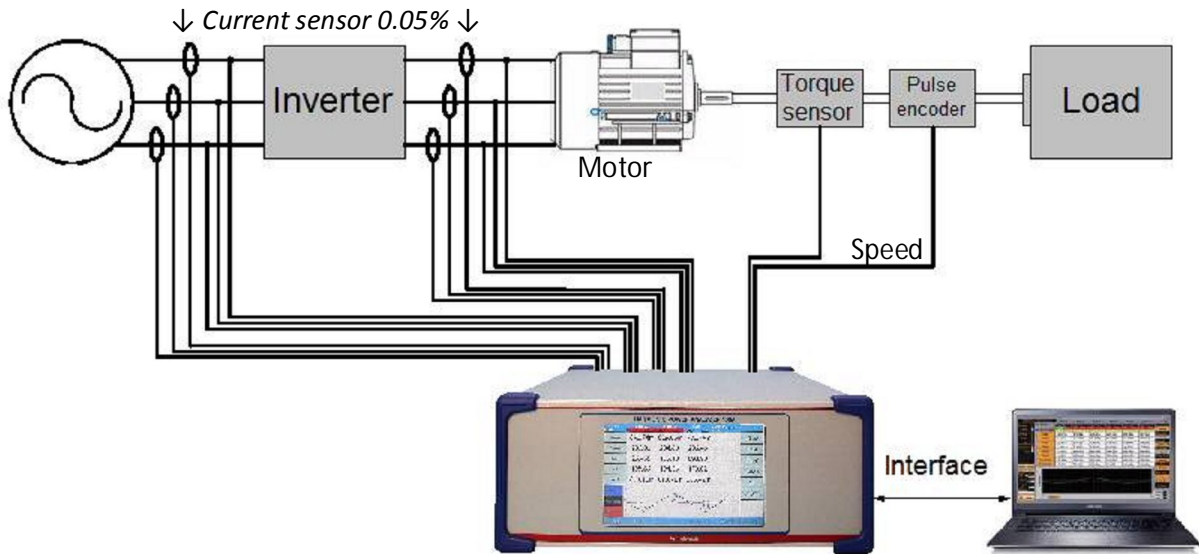

$$\text{Overall Efficiency} = 4\pi \cdot \text{rotation per second} \cdot \text{torque} / (\text{nr_poles}) \cdot (P1+P2+P3)$$

First, run a no load motor test. The interface command **"COMP:MOT1_Loss?"** stores the motor loss. For tests on loaded motor this loss is subtracted to compute motor output power. With the command **"COMP:MOTOR1?"** all motor values: input power, output power, torque, slip, speed (rpm), and efficiency are sent to the PC.

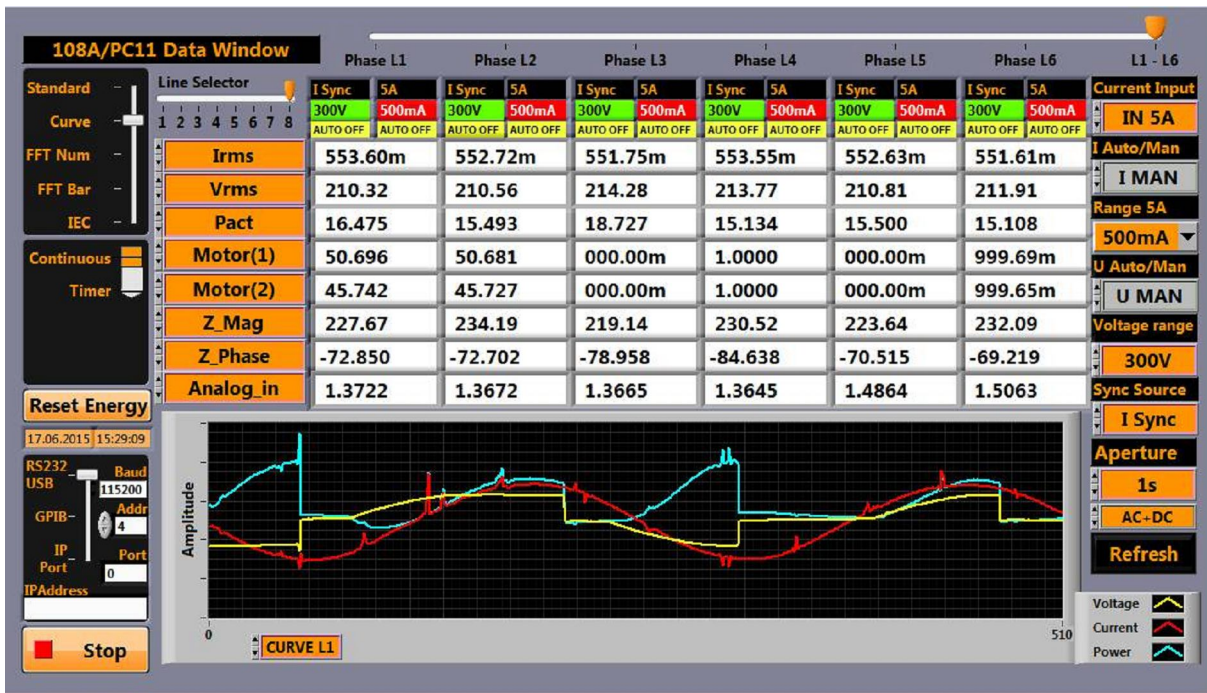

The external torque- and temperature inputs are transferred to the PC by the command **"COMP:ANIN?"**. Run tests at different loads to obtain graphs of slip versus torque, input power versus torque, and efficiency versus torque. Remember, the speed- and torque inputs can be scaled to read actual rpm and Nm.

Circuit Model of an Asynchronous Induction Motor

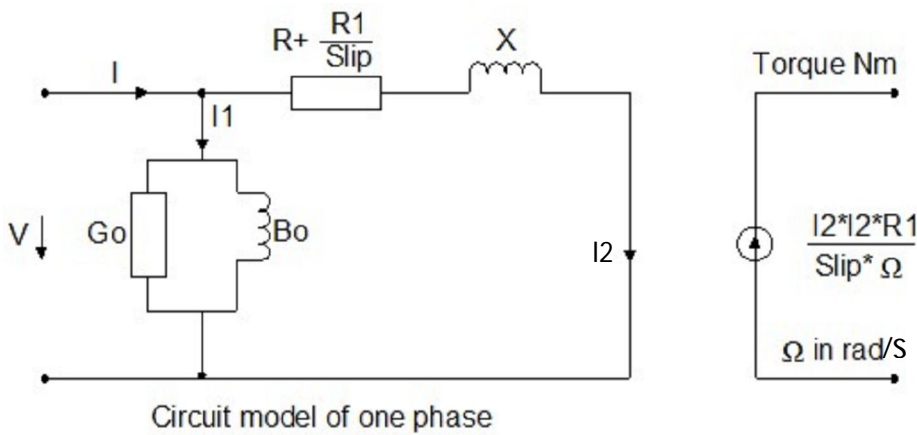

Perform a no-load test and a blocked-rotor test.

The circuit elements can be determined.

No-load test

Measure the fundamental of voltage, current, impedance and phase angle. Calculate G_0 and B_0 .

Blocked-rotor test:

Measure the fundamental of voltage, current, impedance, and phase angle. From a DC measurement obtain the ohmic resistance R_{dc} . Approximate $R = 0.5R_{dc}$. Calculate R_1 and X from fundamental of impedance and phase.

Once the elements of the equivalent circuit are determined various motor characteristics can be plotted, such as: torque / power / power-factor versus slip.

Measurements on loaded Motor

Operate the motor at various load points. Store the measurements using the PC Operating Software, alternatively store the measurements on the Power Analyzer in Excel. Plots like torque versus slip, input power versus slip, and many more graphs can be obtained.

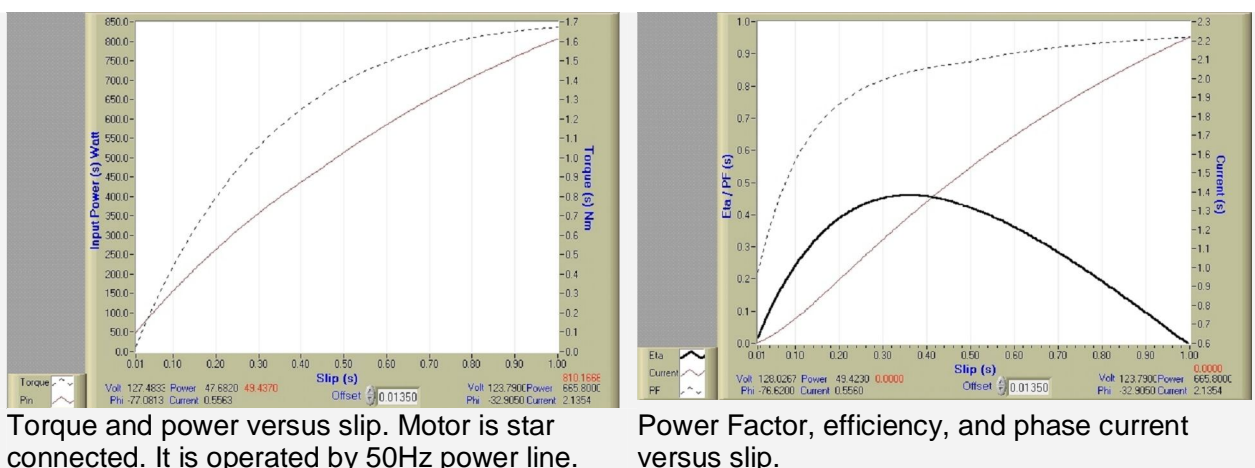

Measurement of Start-up Behaviors of Inverter Driven Induction Motor

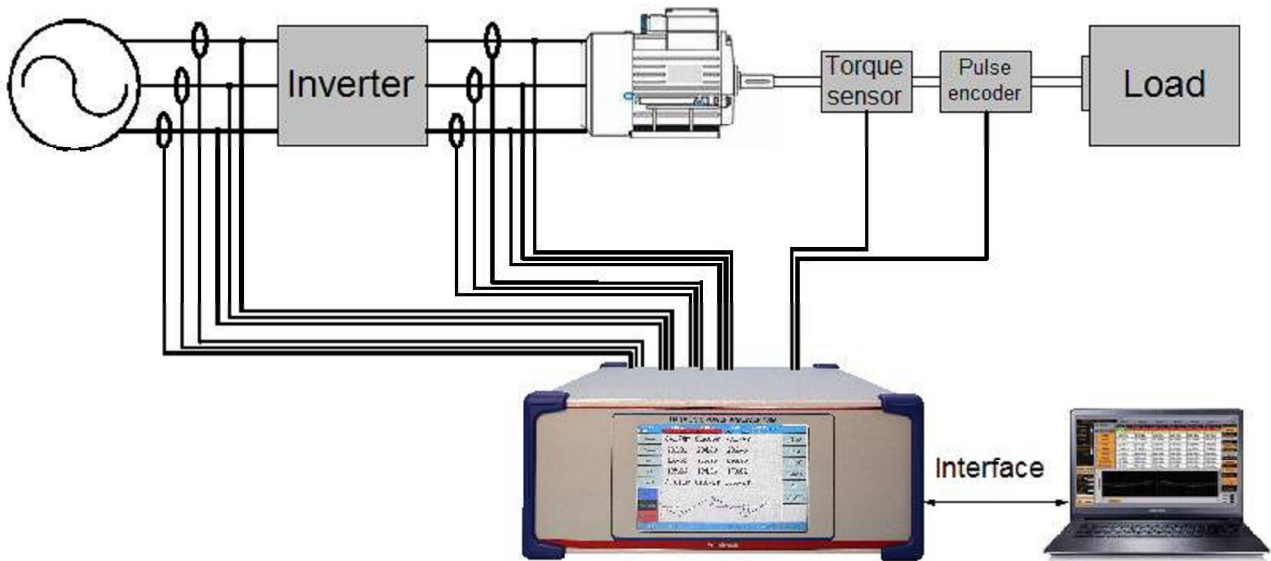

Select **LOGGING Mode**

Select voltage- and current ranges such that at start-up no range overload occurs. Select current- or external synchronization **to all installed phases on the 108A**, set "CYCLE" to 1, 2, 3, or any other value. Apply the synchronization to all phases installed in the Power Analyzer. Finally start the system.

If you selected DYCLE = 1 the 108A sends every period one data set per phase to the PC. A 6-phase instrument sends 6 data sets to the PC, phase 1 first. Each data set contains: Frequency, A, V, W, PF, VA, Wh, and VAh. A 6-phase 108A transmits 6 data sets per 20ms (maximum speed). Stop the measurement when the system is in steady state and analyze the data using EXCEL.

Simultaneous Measurement of 2 Synchronous Motors (PMSM, BLDC)

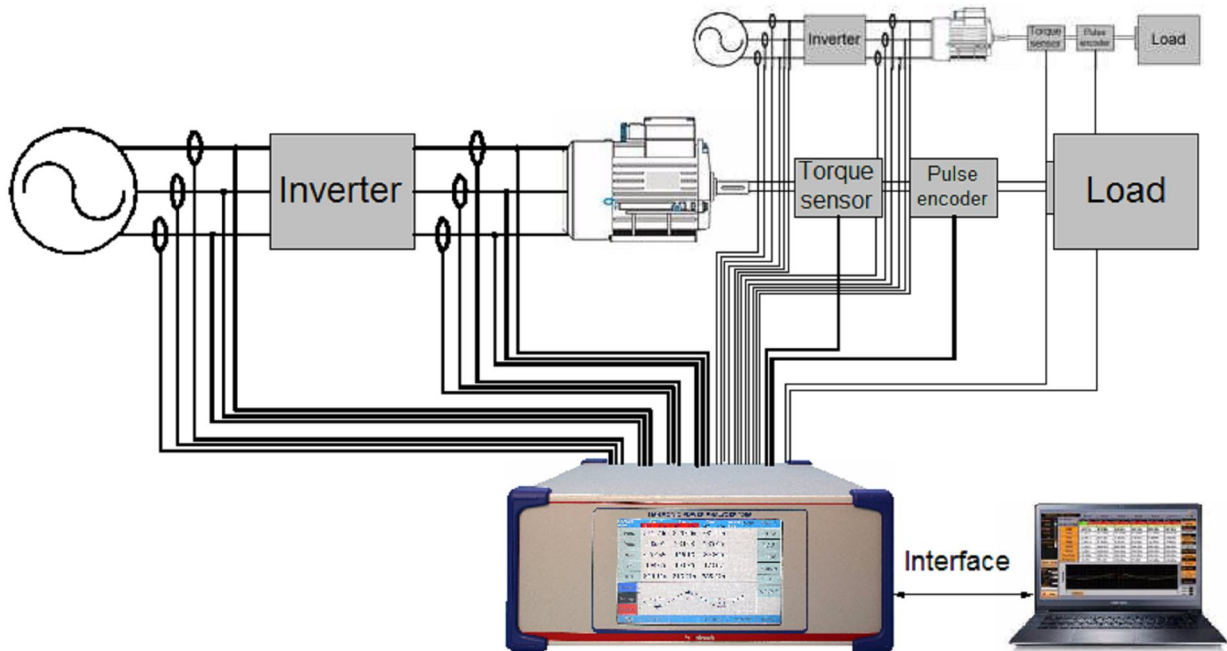

A wide range of synchronous motors are on the market (PMSM, IPMSM, BLDC). The power consumption ranges from mW to 500kW. Many different constructions are in use. They all have in common that the magnetic field rotation (2 phase or 3 phase) is electronically generated. A wide range of speeds (rpm) are available.

Advantage of the 108A Power Analyzer

For medium size-, small-, and very small motors the 108A provides per phase 3 direct current inputs: 1mA-2A, (for small motors) 15mA-7A, and 1A to 40A (for medium size motors). For very large motors high precision (0.004 %) broad band current sensors up to 700A are available. The sensor output is simply connected to the 1mA-2A input on the 108A. To display actual currents, scaling per phase is available. Also, analog inputs and speed inputs can be scaled. The 108A measure all motor parameters, current, voltage, power, and their harmonics, impedance, and phase angles simultaneously. This is important because electronically generated waves include harmonics (BLDC) and noise (PMSM).

Circuit Model of a Synchronous Motor

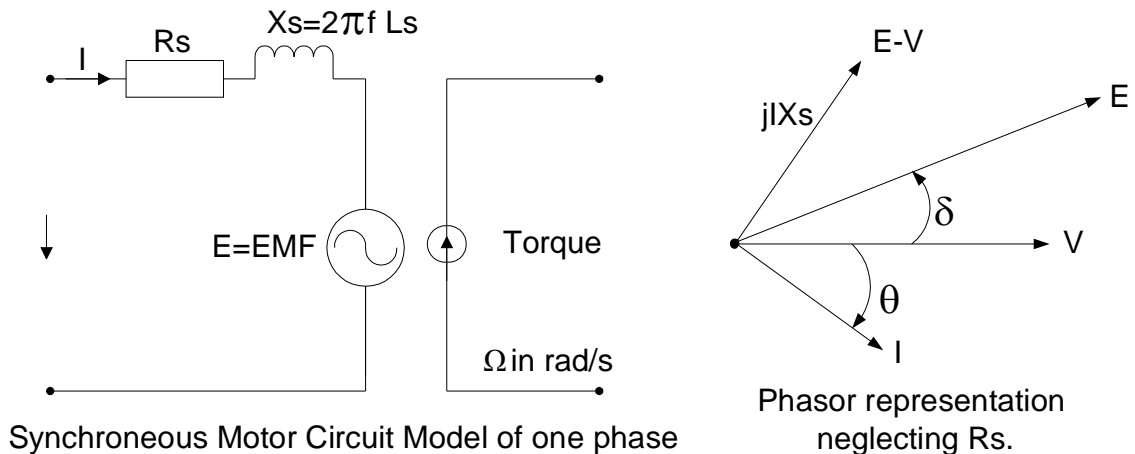

Normally, in a synchronous motor R_s is much smaller than X_s .

From a blocked rotor test

$R_s + X_s$ can be determined (R_s and X_s are somewhat current dependent). Measure impedance and phase angle θ : $Z = R_s + j2\pi f L_s$. From this simple model the electromotive force E and power angle δ can be calculated.

Maximum torque developed by a PMSM-, IPMSM, or BLDC-motor depends very much on its construction. The torque is a function of power angle δ . Their main advantages are low loss and the ability to run at very high speeds (IPMSM).

(There is no need to go through the trouble to perform the mathematics of Clark Transformation followed by the Park Transformation to get to the d, q - coordinates. It remains the proof that $L_s = \frac{1}{3}\sqrt{L_d^2 + L_q^2}$. For PMSM $L_d = L_q$, high speed motors IPMSM $L_d < L_q$).

PMSM = Permanent magnet synchronous motor
 IPMSM = Interior permanent magnet synchronous motor
 BLDC = Brushless DC electric motor

Transient Performance of Synchronous Motors

The 108A also measures motors in transient state (start-up, speed change, load change) using the **Logging** measure mode or the **Power-Speed** measure mode.

Logging Mode

Logging 12:12:32 PM	L1 5A Vs 10V 50mA	L2 5A Vs 10V 50mA	L3 5A Vs 10V 50mA	Average Sum <input type="checkbox"/> OFF	PAGE 1
Freq	50.438	50.441	50.438		IN 5A
Arms	30.753	30.807	30.760		AUTO A
Vrms	234.30	234.29	234.38		AUTO V
Watt	7.2036k	7.2156k	7.2060k		Sync V
PF	999.70m	999.69m	999.46m		1s
VA	7.2058k	7.2178k	7.2099k		WAVE
Wh	30.984	31.036	30.994		
VAh	30.993	31.045	31.011		
					STOP

At end of programmed time interval (1, 2, 3, ... periods), frequency, A, V, PF, VA, Wh, and VAh of each phase are transmitted to the PC. Data are stored. In EXCEL graphs can be generated.

Power Speed Mode

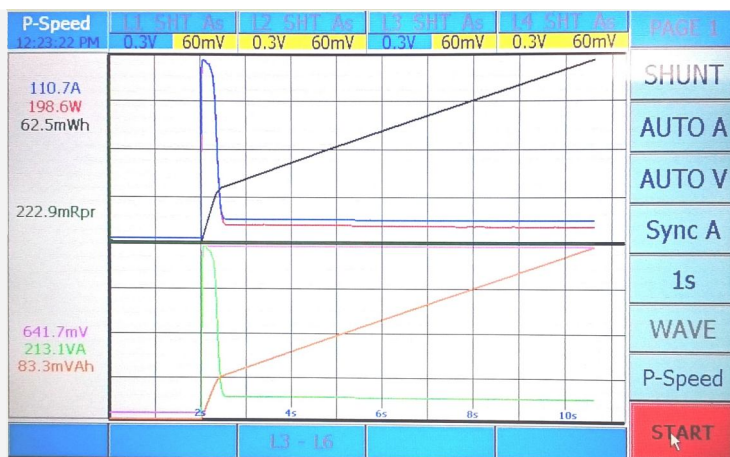

Use it for high speed IPMSM with fast changing signal frequency. In 20ms intervals averaged current and voltage, 3-phase power, 3-phase apparent power, and speed (rpm) are sent to PC. In EXCEL graphs like power versus rpm can be drawn. Plots on the 108A display are drawn.

Transient wave

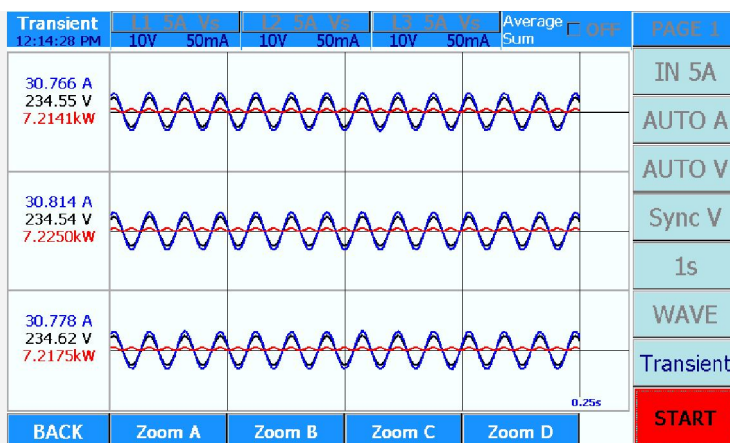

At operating points of interest the simultaneous wave forms of all 6 phases can be viewed (current, voltage and power). To view details sectors of wave forms A, B, C, or D can be expanded.