

PRODUCT DESCRIPTION

The Ranco ETC is a microprocessor based electronic temperature control designed to provide on/off control for commercial heating, ventilating, air conditioning and refrigeration. The ETC is equipped with a liquid crystal display (LCD) that provides a constant readout of the sensed temperature, and a touch keypad that allows the user to easily and accurately select the setpoint temperature, differential and heating/cooling mode of operation. The ETC NEMA Type 4X control can accept either 120 or 208/240V AC or low voltage (24V AC) input power.



APPLICATIONS

All ETC NEMA Type 4X controls have enclosures rated watertight for outdoor use. With its wide temperature setpoint range and selectable heating and cooling modes, the ETC can be used for a wide variety of applications including bulk milk coolers, refrigerated storage, cooling towers, unit heaters, ventilation fan cycling, trace heating and many other applications where two stages of heating or cooling are called for. In addition, the ETC NEMA Type 4X control is designed to meet the requirements of Article 547 of the National Electric Code for use in agricultural buildings such as poultry houses and livestock barns.

FEATURES

- Wide setpoint temperature range (-30°F to 220°F) and differential adjustment (1°F to 30°F)
- Simple keypad programming of setpoint temperature, differential and cooling/heating modes
- Two individually programmable stages for heating and/or cooling
- LCD display readout of sensor temperature, control settings, relay status and onboard diagnostics
- LED (Light Emitting Diode) backlight to improve visibility of the display in low light ambient applications.
- IP67 rated (water and dust resistant) thermistor-based probe to remotely monitor temperature
- The sensor probe can be retrofitted in the field by the use of factory installed interconnect
- Remote temperature sensing up to 400 feet
- Two SPDT output relays
- User-selectable Fahrenheit/Celsius scales
- Lockout switch to prevent tampering by unauthorized personnel
- NEMA Type 4X enclosure rated watertight for outdoor application
- Designed to meet Article 547 of the National Electrical Code for use in agricultural buildings
- Anti-short Cycle Compressor Delay for cooling applications

SPECIFICATIONS

Input Voltage	120 or 208/240V AC, 24V AC optional, 50/60 Hz
Temperature Range	-30°F to 220°F
Differential Range	1°F to 30°F
Switch Action	SPDT
Sensor	Thermistor, 1.94 in. long x 0.25 in. diameter with 8 ft. cable, IP67 rated
Power Consumption	120/208/240 VAC: 100 milliamps 24V AC: 2-6 VA

Relay Electrical Ratings

	120V	208/240V
NO Contact		
Full-load amps	9.8 Amps	4.9 Amps
Locked rotor amps	58.8 Amps	29.4 Amps
Resistive amps	9.8 Amps	4.9 Amps
Horsepower	1/2 HP	1/2 HP
NC Contact		
Full-load amps	5.8 Amps	2.9 Amps
Locked rotor amps	34.8 Amps	17.4 Amps
Resistive amps	5.8 Amps	2.9 Amps
Horsepower	1/4 HP	1/4 HP

Pilot Duty: 125 VA at 120/208/240 VAC

Control Ambient Temperature

Operating	-20°F to 140°F (-29°C to 60°C)
Storage	-40°F to 176°F (-40°C to 80°C)
Enclosure	NEMA Type 4X Outdoor, Plastic
Agency Approvals	UL Listed, File E94419, Guide XAPX CSA Certified, File LR68340, Class 481302

ETC ORDERING INFORMATION

Uni-Line Number	OEM Number	Input Voltage	No. of Stages
ETC-241000-000	ETC-241020-000	120/240	2
ETC-242000-000	ETC-242020-000	24	2

OPERATION

Liquid Crystal Display (LCD)

The LCD display provides a constant readout of the sensor temperature and indicates if either of the two output relays is energized. When the **S1** annunciator is constantly illuminated during operation, the Stage 1 relay is energized. Likewise, when the **S2** annunciator is constantly illuminated during operation, the Stage 2 relay is energized. The display is also used with the keypad to allow the user to adjust the setpoint temperatures, differentials and heating/cooling modes for each stage.

Backlight

When any of the 3 mode keys are pressed, the backlight is activated and the ETC is in control mode. Press the SET key to begin program mode.

Control Setup

The temperature setpoint refers to the temperature at which the normally open (NO) contacts of the output relay will open. Determine the loads to be controlled and the operating modes required for each stage, cooling or heating.

- When the cooling mode is chosen, the differential is above the set point. The relay will de-energize as the temperature falls to the setpoint.
- Anti-short Cycle Compressor Delay for cooling. After a relay de-energizes, the ETC will prevent the relay from turning on until a configurable time has occurred to protect compressor.
- When the heating mode is chosen, the differential is below the set point. The relay will de-energize as the temperature rises to the setpoint.

The ETC two stage control can be set up for two stages of heating, two stages of cooling or one stage cooling plus one stage heating. Refer to Figures 1, 2 and 3 for a visual representations of different control setups.

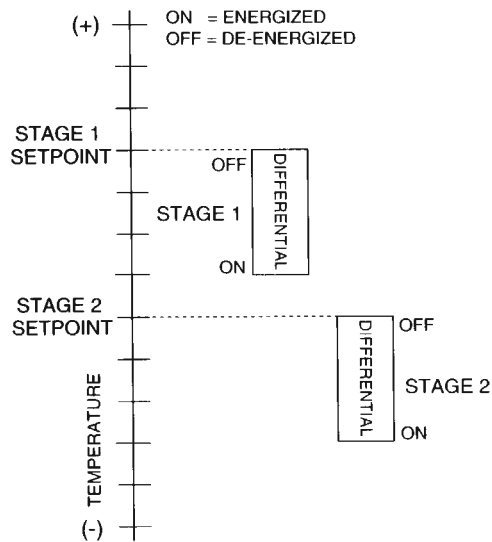

Figure 1: Two Stage Heating Example

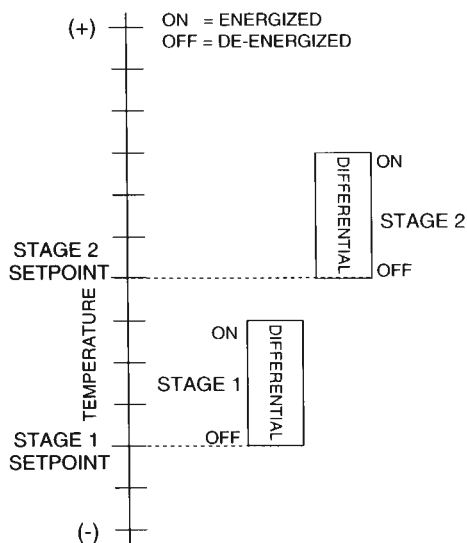

Figure 2: Two Stage Cooling Example

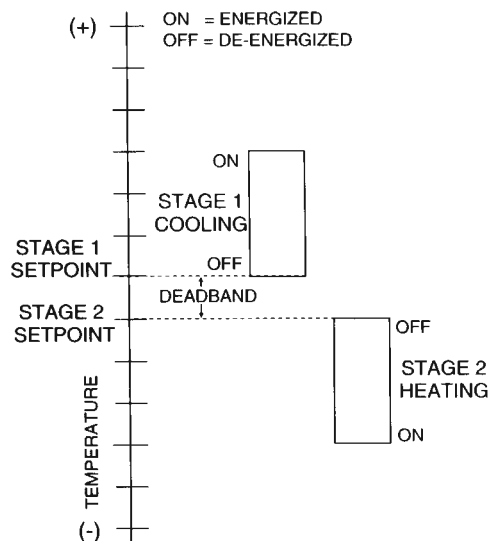

Figure 3: One Stage Cooling and One Stage Heating Example

Programming Steps and Display Mode

The ETC two stage can be programmed in seven simple steps using the LCD display and the three keys on the face of the control.

Step 1 To start programming, press the **SET** key once to access the Fahrenheit/Celsius mode. The display will show the current status, either **F** for degrees Fahrenheit or **C** for degrees Celsius. Then press either the up \uparrow or down \downarrow arrow key to toggle between the **F** or **C** designation.

Stage 1

Step 2 Press the **SET** key again to access the stage 1 setpoint. The LCD will display the current setpoint and the **S1** annunciator will be blinking on and off to indicate that the control is in the setpoint mode. Then press either the up \uparrow key to increase or the down \downarrow key to decrease the setpoint to the desired temperature.

Step 3 Press the **SET** key again to access the stage 1 differential. The LCD will display the current differential and the **DIF 1** annunciator will be blinking on and off to indicate that the control is in the differential mode. Then press either the up \uparrow key to increase or the down \downarrow key to decrease the differential to the desired setting.

Step 4 Press the **SET** key again to access the stage 1 cooling or heating mode. The LCD will display the current mode, either **C1** for cooling or **H1** for heating. Then press either the up \uparrow or down \downarrow key to toggle between the **C1** or **H1** designation.

Step 5 Press the **SET** key again to access the Anti-short Cycle Compressor Delay when in Cooling Mode. Press the up \uparrow or down \downarrow keys to set the delay from 1 to 20 minutes. Press **SET** key again to finish the programming.

Stage 2

Step 6 Press the **SET** key again to access the stage 2 setpoint. The LCD will display the current setpoint and the **S2** annunciator will be blinking on and off to indicate that the control is in the setpoint mode. Then press either the up \uparrow key to increase or the down \downarrow key to decrease the setpoint to the desired temperature.

Step 7 Press the **SET** key again to access the stage2 differential. The LCD will display the current differential and the **DIF 2** annunciator will be blinking on and off to indicate that the control is in the differential mode. Then press either the up \uparrow key to increase or the down \downarrow key to decrease the differential to the desired setting.

Step 8 Press the **SET** key again to access the stage 2 cooling or heating mode. The LCD will display the current mode, either **C2** for cooling or **H2** for heating. Then press either the up \uparrow or down \downarrow key to toggle between the **C2** or **H2** designation. Press the **SET** key once more and programming is complete.

Step 9 Press the **SET** key again to access the Anti-short Cycle Compressor Delay when in Cooling Mode. Press the up \uparrow or down \downarrow keys to set the delay from 1 to 20 minutes. Press **SET** key again to finish the programming.

Refer to Page 3 for an illustrated guide to programming the ETC.

NOTE: The ETC will automatically end programming if no keys are depressed for a period of thirty seconds. Any settings that have been input to the control will be accepted at that point.

All control settings are retained in non-volatile memory if power to ETC is interrupted for any reason. Re-programming is not necessary after power outages or disconnects unless different control settings are required.

Program Mode Displays

Step	Annunciator	Description	Display
1	F or C	Fahrenheit or Celsius Scale	
2	S1 (blinking)	Stage 1 Setpoint Temperature	
3	DIF 1 (blinking)	Stage 1 Differential Temperature	
4	C1/H1	Stage 1 Cooling or Heating Mode	
5	D1	Cooling Delay Set to 1-20 Minutes	
6	S2 (blinking)	Stage 2 Setpoint Temperature	
7	DIF 2 (blinking)	Stage 2 Differential Temperature	
8	C2/H2	Stage 2 Cooling or Heating Mode	
9	D2	Cooling Delay Set to 1-20 Minutes	

Lockout Switch

The ETC is provided with a lockout switch to prevent tampering by unauthorized personnel. When placed in the **LOCK** position, the keypad is disabled and no changes to the settings can be made. When placed in the **UNLOCK** position, the keypad will function normally.

To access the lockout switch, disconnect the power supply and open the control. The switch is located on the inside cover about 2 inches above the bottom. (see Figure 4). To disable the keypad, slide the switch to the left **LOCK** position. To enable the keypad, slide the switch to the right **UNLOCK** position. All ETC controls are shipped with this switch in the **UNLOCK** position.

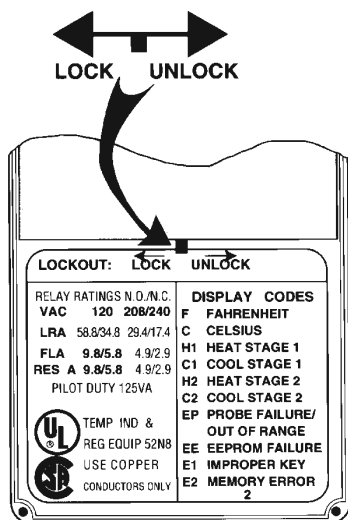

Figure 4: Lockout Switch

TROUBLESHOOTING ERROR MESSAGES

Display Messages

- E1 Appears when either the up ↑ or down ↓ key is pressed when not in the programming mode.
To correct: If the E1 message appears even when no keys are being pressed, replace the control.
- E2 Appears if the control settings are not properly stored in memory.
To correct: Check all settings and correct if necessary.
- EP Appears when the probe is open, shorted or sensing a temperature that is out of range.
To correct: Check to see if the sensed temperature is out of range. If not, check for probe damage by comparing it to a known ambient temperature between -30°F and 220°F. Replace the probe if necessary.
- EE Appears if the EEPROM data has been corrupted.
To correct: This condition cannot be field repaired. Replace the control.
- CL Appears if calibration mode has been entered.
To correct: Remove power to the control for at least five seconds. Reapply power. If the CL message still appears, replace the control.

INSTALLATION INSTRUCTIONS

WARNING:



Electrical Shock Hazard - Turn off power at the main power source before installing the ETC control. DO NOT restore electrical power to the unit until the ETC control is properly installed and cover assembled.



Fire Hazard - DO NOT locate the ETC control in an explosive atmosphere as a fire could result due to possible spark generation in the control.



All ETC Controls are designed as temperature controls and are not used as temperature limit controls.



Where failure or malfunction of the ETC control could cause personal injury or property damage, other devices (limit or safety controls) or systems (alarm or supervisory) intended to warn or protect against failure or malfunction of the ETC control must be installed.

INSTRUCTIONS CONCERNANT L'INSTALLATION

AVERTISSEMENT



Risque de choc électrique - Couper le courant à la source d'alimentation principale avant d'installer le contrôleur ETC. NE PAS rétablir l'alimentation électrique de l'appareil avant que le contrôleur ETC ne soit correctement installé et que le couvercle ne soit assemblé.



Risque d'incendie - Ne pas placer le contrôleur ETC dans une atmosphère explosive car un incendie pourrait être déclenché par d'éventuelles étincelles survenant dans le contrôleur.



Toutes les commandes de l'ETC sont conçues pour contrôler la température et ne sont pas utilisées comme témoins des limites de température.



Si une défaillance du contrôleur ETC peut causer des blessures ou des dommages matériels, d'autres dispositifs (contrôles des limites ou de la sécurité) ou des systèmes (d'alarme ou de surveillance) destinés à prévenir ou à protéger contre une défaillance ou un dysfonctionnement du contrôleur ETC, doivent être installés.



CAUTION

Read all of the information in these instructions before installing or operating the ETC control.

The schematic drawings and other information included in these installation instructions are for the purpose of illustration and general reference only.

ETC controls are not to be located in areas of significant moisture, dirt or dust as use of the control in such environment may cause personal injury or property damage and is likely to shorten the control life.

It is the responsibility of the installer and the user to assure that the application and use of the ETC control is in compliance with all applicable federal, state, and local laws, regulations and ordinances, including, without any limitation, all requirements imposed under the National Electric Code and any applicable building codes.



PRÉCAUTIONS

Lire toutes les informations contenues dans ces instructions avant d'installer ou d'utiliser le contrôleur ETC.

Les schémas et toutes les autres informations figurant dans ces instructions d'installation sont indiqués à des fins d'illustration et de référence générale seulement.

Les contrôleurs ETC ne doivent pas être placés dans des zones ayant un taux d'humidité élevé, de la saleté ou de la poussière, car l'utilisation du contrôleur dans de tels environnements peut engendrer des blessures ou des dommages matériels et est susceptible de raccourcir la durée de vie du contrôleur.

Il est de la responsabilité de l'installateur et de l'utilisateur de s'assurer que l'installation et l'utilisation du contrôleur ETC soit faites en conformité avec tous les règlements, lois, et ordonnances fédéraux, provinciaux, et locaux, y compris, sans y être limité, toutes les exigences imposées par la National Electric Code ainsi que tous les codes du bâtiment, en vigueur.

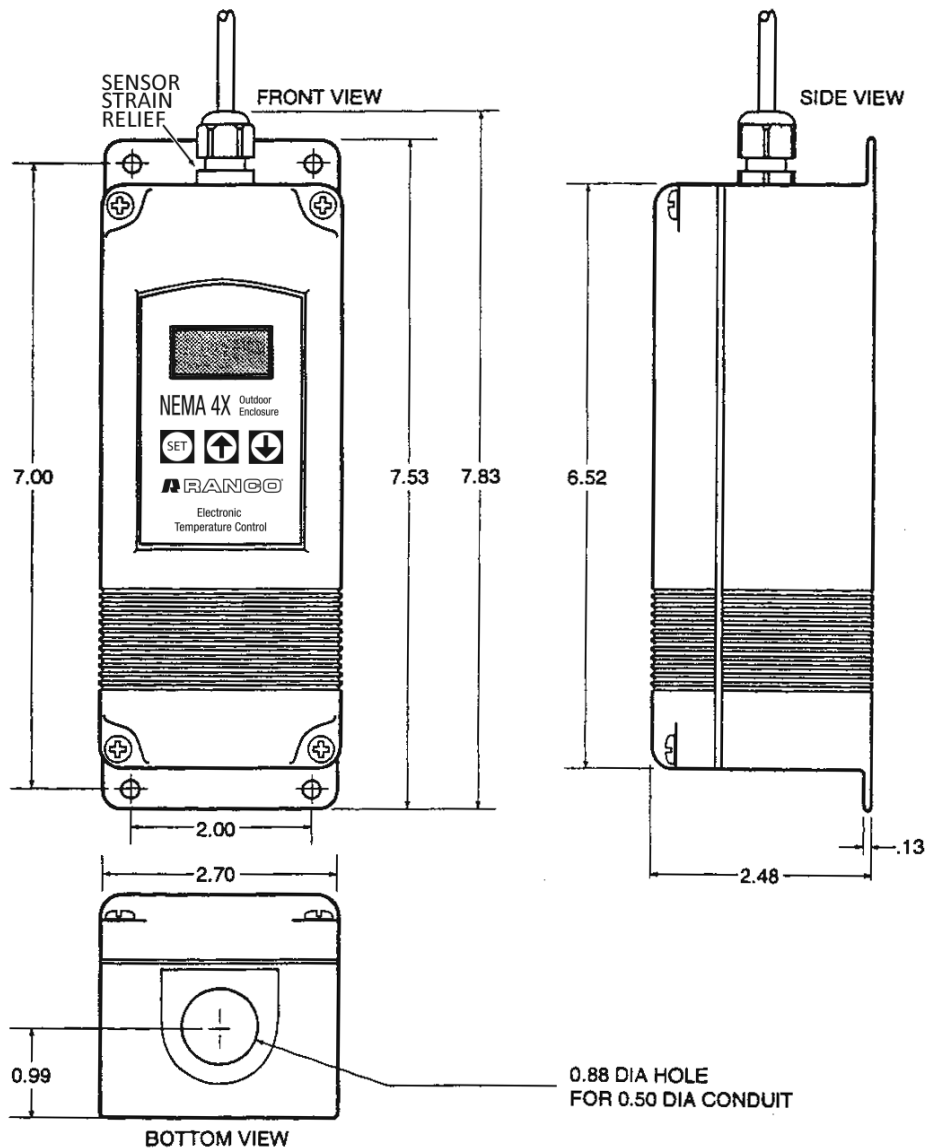

Figure 5: Dimensions (Inches)

CONTROL MOUNTING

Mount the ETC to a wall or any flat surface using a combination of any two or more of the holes located on the back case flanges. The control's components are not position sensitive, but should be mounted so that they can be easily wired and adjusted. Avoid excessive conditions of moisture, dirt, dust and corrosive atmosphere during installation. The ETC NEMA Type 4X control has provisions for a 1/2 inch conduit connection. The conduit hub should be secured to the conduit before securing the hub to the plastic housing of the control. Caution should be exercised not to damage the control circuit board or wiring when installing a conduit connector.

Installation of ETC NEMA Type 4X controls must conform to requirements of the National Electrical Code and Canadian Standards Association. Conduit fittings must be listed by Underwriters Laboratories and Canadian Standards Association as "Liquid-Tight" when installed to the manufacturer's specifications.

ANTI-SHORT CYCLE COMPRESSOR DELAY

When the unit is configured for cooling and there is a call for cooling, the relay will not activate until the Anti-short Cycle Compressor Delay is satisfied. During an Anti-short Cycle Compressor Delay, the temperature will alternate with Cd to indicate the Relay On is delayed.

If Relay 1 is in Anti-short Cycle Compressor Delay, the temperature will alternate with a Cd or S1 icon. If Relay 2 is in Anti-short Cycle Compressor Delay mode, the temperature will alternate with a Cd or S2 icon.

CONTROL WIRING

General

- All wiring should conform to the National Electric Code and local regulations.
- The total electrical load must not exceed the maximum rating of the control (see Specifications).
- Use copper conductors only.
- Electrical leads should not be taut; allow slack for temperature change and vibration.

Input and Output Wiring

For typical wiring diagrams, refer to Figures 6, 7 and 8. All connections are made to the power (lower) circuit board.

FIELD REPAIRS

Field calibrating or repairs to the ETC control must not be attempted. Sensors and replacement controls are available through Ranco wholesalers.

SENSOR MOUNTING

For space sensing, mount the sensor where it will be unaffected by heat/cool discharge or radiated heat sources. Spot sensing requires the sensor to be in good contact with the surface being sensed. The sensor can be inserted in a bulb well for immersion sensing.

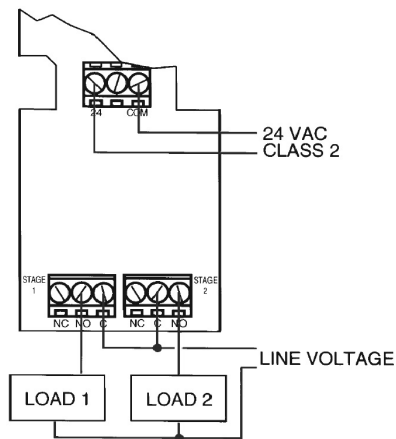

Figure 8: Typical Wiring Diagram for 24V AC Power Input and Line Voltage Switching

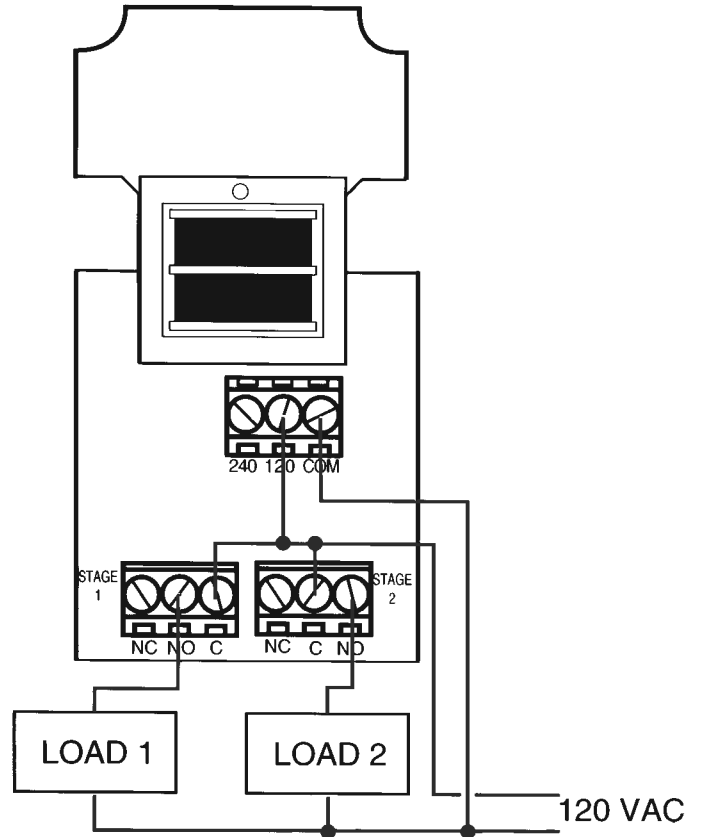

Figure 6: Typical 120 VAC Wiring Diagram.

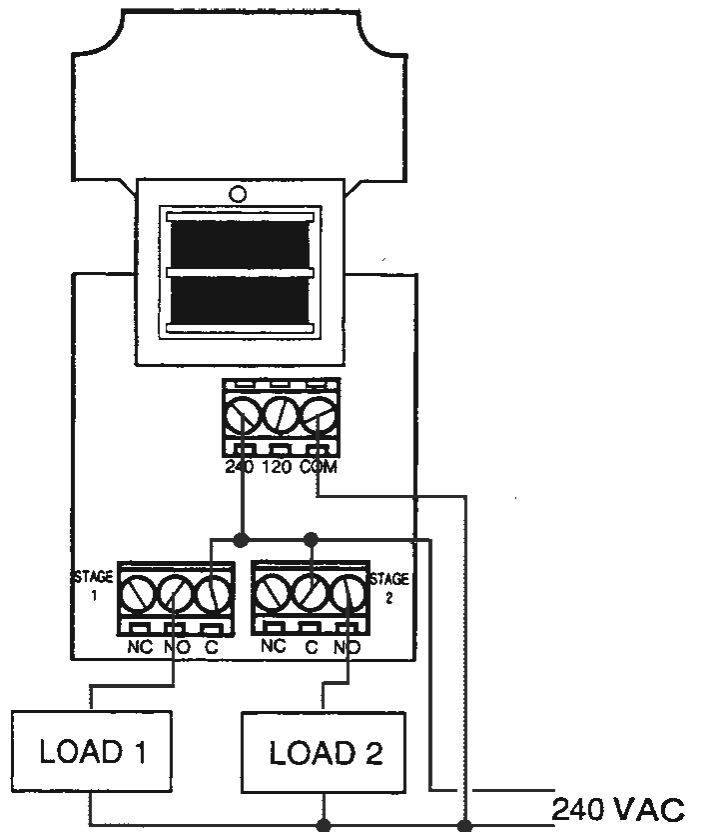

Figure 7: Typical 240 VAC Wiring Diagram.

EXTENDING SENSOR

CAUTION: Sensor wiring splices may be made external from the control.

CAUTION: Disconnect power to control before wiring to avoid possible electrical shock or damage to the controller.

Additional cable can be spliced to the sensor cable to increase the length beyond the standard 8 feet. It can be extended up to 400 feet. The cable should be at least 22 AWG or larger to keep additional resistance to a minimum.

All splices and wire lengths added to the sensor cable should be made according to acceptable wiring practices and should conform to the National Electrical Code and local regulations. Use copper conductors only. Shielded cable is not required. The sensor is not polarity sensitive.

Checkout Procedure

1. Before applying power, make sure installation and wiring connections are correct.
2. Apply power to the control and observe one or more cycles of operation.
3. If performance indicates a problem, check sensor resistance to determine if sensor or control is at fault.
4. To check sensor resistance, disconnect sensor and measure the resistance across the leads while measuring temperature at the sensor.

SENSOR REPLACEMENT

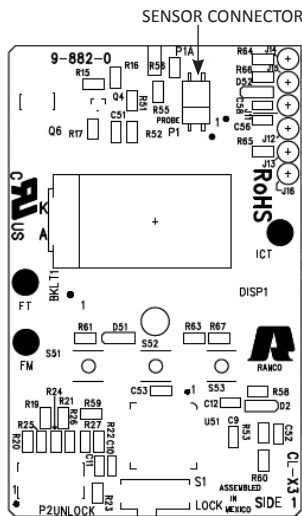

Figure 8: Sensor replacement on Display (Upper) Circuit Board.

Sensor Replacement

ETC models are available with Quick Connect Sensor feature that allows for easy sensor replacement due to damage or wear. To access the sensor connector, disconnect the power supply and open the control. Remove single screw located in the center of the Display Upper Circuit Board and carefully remove Display Board Circuit. Remove Sensor Strain Relief to allow sensor to be removed from unit. See Figure 3 for location of sensor strain relief. The sensor connection is made at the P1 Connector on the Display Upper Circuit Board. See figure 8 for connection information.

**Replacement Sensor - Order
Uni-Line Number 1309007-044
(OEM Number 1309007-048)**



Customer Service Telephone 1.800.304.6563
Customer Service Facsimile 1.800.426.0804
HVACCustomerService@robertshaw.com

For Technical Service
Telephone 1.800.445.8299
TechnicalService@robertshaw.com

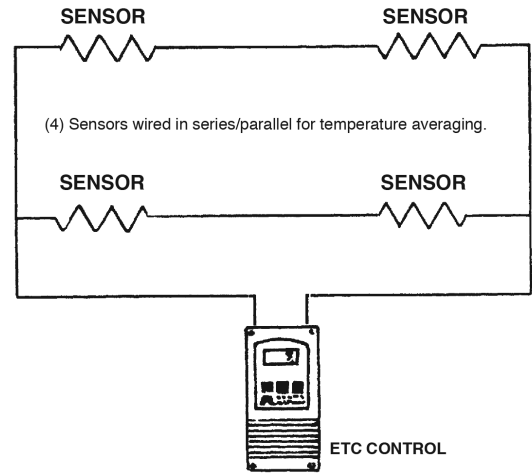

Figure 9

SPECIFICATIONS

The sensor is a negative temperature coefficient (NTC) thermistor sensor. The sensor resistance decreases with temperature increase. It is .25 x 1.94 long with 8 feet #22 AWG cable. The thermistor has a reference resistance of 30,000 ohms at 77 °F (25°C).

IMPORTANT

The schematic drawings and other information included in these instructions are for the purpose of illustration and general reference only. Ranco assumes no responsibility for any unconventional application of this control, unless such application has been approved in writing by Ranco.

Deg. C.	Deg. F.	RES. Nom.
-40	-40	1,010,000
-30	-22	531,000
-20	-4	291,200
-10	14	166,000
0	32	97,960
10	50	59,700
20	68	37,470
25	77	30,000
30	86	24,170
40	104	15,980
50	122	10,810
60	140	7,464
70	158	5,200
80	176	3,774
90	194	2,753
100	212	2,036
110	230	1,531

Figure 10:
Resistance vs Temperature
Sensor including 8 foot cable.



Robertshaw®, Ranco®, Paragon® and Uni-Line® are trademarks of Robertshaw its subsidiaries and/or affiliated companies. All other brands mentioned may be the trademarks of their respective owners.

www.robertshaw.com
©2018 Robertshaw
02/18 – 352-00010-00 RevD