

***Kendon* Stand-Up™** **TRAILERS & LIFTS**

KENDON PREMIUM SERIES STAND-UP™ TRAILER OWNER'S MANUAL



KENDON INDUSTRIES, LLC
2990 E. Miraloma Ave.
Anaheim, CA 92806 USA
Tel 714-630-7144 • Fax 714-630-7132

www.KendonUSA.com

Rev. 032323

This page intentionally left blank.

⚠ WARNING

WARNING: Serious injury, death and/or property damage could result through improper use of this product, including crushing or severing type injuries.

WARNING: Thoroughly read and understand all instructions and owner's manual(s) before using the trailer.

WARNING: For Adult Use Only. Keep children away from trailer at all times.

WARNING: You must check to ensure that the front wheel chock on the trailer will not contact the bottom rear of your front fender, fairing or other parts of your motorcycle **BEFORE** loading.

WARNING: Trailer should only be loaded and unloaded on a stable flat surface with the trailer properly connected to the tow vehicle.

WARNING: Properly attach the loading ramps as per this manual's instructions.

WARNING: Obey trailer cargo capacity limits.

WARNING: There is an inherent risk in the loading and unloading process. Failure to load your vehicle properly could result in serious injury and or property damage. Load and unload at your own risk.

Trailer owner is responsible for complying with all the recommended procedures in this instruction manual. Use at your own risk. Kendon is not responsible for injury, liability, property damage and/or any consequential damage(s) caused by the misuse of this product.

⚠ CAUTION

LOADING

Properly attach the loading ramps as per this manual's instructions.

Ensure motorcycle clears trailer fender and license plate holder when loading and unloading.

Ensure the wheel chock on the rail is in the open position (pg. 16).

⚠ CAUTION

LOADING RAMPS

How to use the ramps on your Kendon Premium Series Trailer:

Insert the ramp hook as shown below between the tubular rails on the rear folding section of the trailer.

This example might make it easier to understand: if the ramp hook was a spoon, it should be positioned as if you were using it to eat soup, rather than to pour soup out.

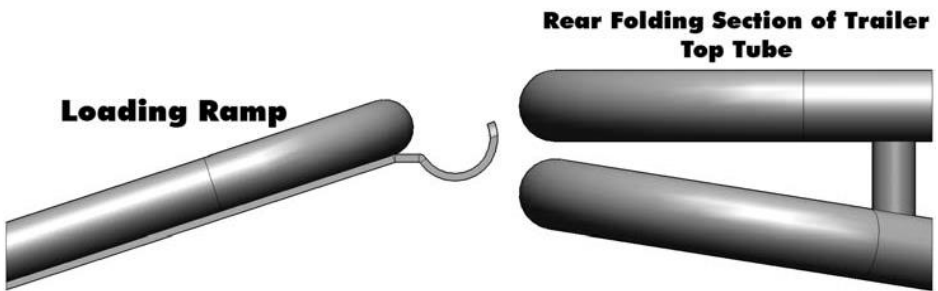

Please contact us directly at 714-630-7144 or info@KendonUSA.com if you have any questions about ramp use or attachment.

Kendon Premium Series Trailer Owner's Manual

Congratulations on your purchase of a Kendon Premium Series™ Stand-Up™ Motorcycle Trailer. Safety is our number one concern. Before using this product, please take the time to completely read this Premium Series trailer Owner's Manual and familiarize yourself thoroughly with the parts on your new Kendon Premium Trailer. In addition to this manual, be sure to read and follow the separate usage instructions for your specific model Premium Series Stand-Up™ Trailer (if applicable).

Read and understand all warnings and warning labels on the trailer before use. Do not remove any warning labels or warning tags except for the labels specifically stating to be removed and the warning label on the coupler that must be removed before use.

Towing any trailer, proper loading, unloading and securing of the load is serious business with inherent risks. Serious injury, death and/or property damage can result to operator and/or others through improper use of this product.

If you have any questions or need additional help or instructions, please contact us directly at 714-630-7144 or info@KendonUSA.com.

Visit us at **www.KendonUSA.com** for product updates, new products, and support.

WARNING

Risk of injury and/or property damage: There is an inherent risk in the loading and unloading process. Failure to load your vehicle properly could result in serious injury and/or property damage.

Most Common Hazards

- Failure to read instructions.
- Loss of balance while loading.
- Slippery surfaces (wet, snow and/or icy surfaces are dangerous to load and unload on).
- Trailer not properly connected to tow vehicle. This is a common and expensive error causing the trailer to tip up and run into the back of your tow vehicle and/or causing a possible fall in the loading process. This can also cause expensive damage to tow vehicle.
- Loading a vehicle when under the influence; load and unload with the same mental capacity needed for riding or driving.
- Rider Error.

This is not a complete list of all risks. Physical strength, weight of vehicle and riding skills all vary widely. Only you can determine your comfort level through safe practice. Kendon wants you safe!

Loading and Unloading Process

Loading and unloading a motorcycle onto any vehicle, either a trailer or a pick-up truck requires certain skills and techniques. Kendon recommends using two spotters while practicing the loading and unloading technique with your bike with your abilities. Most incidents occur from first time users with no experience in loading and unloading a motorcycle. Practicing the process with two spotters is highly recommended. For your added protection, Kendon recommends wearing your safety riding gear during the loading/unloading process.

WARNING

LOAD, UNLOAD AND TOW AT YOUR OWN RISK. KENDON INDUSTRIES, LLC IS NOT RESPONSIBLE FOR ANY INJURY, LIABILITY, PROPERTY DAMAGE AND/OR CONSEQUENTIAL DAMAGE(S) CAUSED BY LOADING AND UNLOADING A VEHICLE.

If you have any questions or need additional help or instructions, please contact us directly at 714-630-7144 or info@KendonUSA.com.

Usage Instructions for Kendon Premium Series Trailers

HIGHLIGHTS

1. Your tow vehicle must have an approved ball height to carry the maximum approved weight for your loaded trailer (Pg. 10).
2. For the single, dual, 3-Rail Combo, and SXS/ATV Utility Stand-Up™ transports, the top of the ball hitch must be approximately 19 to 21 inches above the ground surface when the vehicle is loaded (Pg. 10). For the Trike transport, the correct ball height is approximately 15" from the ground. All Kendon Stand-Up™ trailers must be LEVEL when being towed.
3. Use a Class 2 or greater trailer hitch (Pg. 10).
4. Grease wheel bearings after the first 50 miles, and every 6,000 miles/3-months thereafter. Use the easy access dust cap cover on each wheel (Pg. 9).
5. Either one or two Cruiser type motorcycles can be transported on the two-rail trailers. The independent trailer suspension is designed to tow and track perfectly with one or two motorcycles on board. A single motorcycle can be transported on either the left or right side of the trailer (Pg. 9).
6. Tie-Downs: We **require 4 tie downs per bike**, two straps on the front and two on the rear. We recommend using only Kendon high quality locking-ratchet tie down straps for safety (Pg. 14).
7. Front Tie Down procedure: Use two ratchet tie-down straps on the front fork, compressing suspension to 75% of travel (see Pg. 14 & tie down diagram). **DO NOT OVERTIGHTEN** straps. Correct tie tension will allow room for the motorcycle suspension to function ensuring that the motorcycle will not bounce as the trailer goes over bumps.
8. Rear Tie-Down Procedure: Use two ratchet tie-down-straps on the rear of the motorcycle connecting the frame of the motorcycle to the tie-down points IN-FRONT of the hinge on the trailer axle (Pg. 15).
9. Unless you have a Ride-Up model trailer, **NEVER RIDE** the motorcycle onto the trailer! **ALWAYS** walk the motorcycle onto the trailer when loading (Pg. 16).
10. Hook up the trailer lights prior to operation (Pg. 8-9).

11. Always use the safety-cables/harnesses when towing the trailer, please cross them when attaching. (Pg. 11).
12. Obey trailer cargo capacity limits. Premium Series Single Rail Transport limit - 1,000 pounds. Premium Series Dual Rail Transport limit - 2,000 pounds. Three Rail/Dirt Bike Combo Trailer limit - 1,500 pounds. SXS / ATV / Utility Trailer limit – 2,000 pounds. Trike Trailer limit – 2,000 pounds (Pg. 13).
13. When towing the trailer empty, secure the rear section in folded/closed position using the rubber latch. Always stow trailer folded and secured when empty (Pg. 20).
14. Trailer Limited Warranty (Pg. 30). Axle Limited Warranty (Pg. 31).

Thoroughly read and understand these instructions and the Owner's Manual for your specific model Premium Series™ Stand-Up™ Trailer, where applicable.

Un-Crating and Assembly Instructions

To ensure your satisfaction with our trailer, the removal of the trailer from the crate and the installation of wheels and tail lights must be performed according with the detailed instructions noted below. The assembly and installation require the basic knowledge and use of hand tools listed in the "Recommended Tools" section. If you don't feel you have the capacity to perform this type of installation, or if you have any questions, please contact us via phone at 714-630-7144, 800-847-8618 or via email at info@kendonusa.com.

View our Un-Crating and Assembly video at:

<https://www.youtube.com/watch?v=mK2dl1HDqRM>



Recommended Tools:

1. Pry Bar or Hammer
2. 13/16" or 21 mm Lug Wrench (for Chrome/Steel Wheels & Spare Tire)
3. 11/16" or 17 mm Thin Wall Socket (for Aluminum Raceline Wheels)
4. 7/16" or 11 mm Combination Wrench (For Tail lights)
5. Torque Wrench with appropriate Socket based on wheel option.
6. Wire Cutters
7. Pliers
8. Box cutter or similar

Removal from Crate:

1. Carefully remove packaging, which may include shrink wrap, cardboard packaging and bubble wrap, using a box cutter or similar tool. **BE**

SURE to not cut on edges or near powder coated areas as to not scratch the trailer framework.

2. Cut the metal retaining straps secured to axle and crate on each side of the trailer.
3. Remove the tires, any additional boxes, parts and accessories from the crate.
4. Knock apart the wood sides of the crate to allow for fender and wheel installation.
5. Tilt the trailer forwards slightly so that the tires can slip onto the hubs (*If applicable, the left over wooden crate sides can be used to keep the trailer tilted while wheels are attached*).
6. Attach the wheels/tires to the hubs and hand-tighten lug nuts to hold wheels on the hubs.
7. Tilt the Trailer backwards so that Trailer weight is on the wheels.
8. Roll Trailer out of crate and stand up onto the “casters.”
9. Follow the wheel installation instructions to securely tighten the wheels.

Wheel Installation:

1. Remove wheels from crate and place center wheel caps onto hub (*if equipped, otherwise skip to next step*).
2. Carefully install wheel onto hub and tighten lug nuts with torque wrench to 90-120 foot pounds of torque. Be sure to use the “star” pattern to securely tighten the wheels.
3. Make certain that both hubs and hubcaps are tight, and wheels rotate freely.
4. RE-TIGHTEN lug nuts after the first 50 miles.

Note: Chrome Trailer wheels may have to be balanced before first use. Aluminum Raceline wheels are fully balanced. For steel/chrome wheels please visit your local wheel/tire shop to make sure both wheels and any spare tires are balanced prior to use.

Tail Light Installation:

Note: Your trailer is equipped with STANDARD incandescent tail lights.

1. Split the three wires into individual wires on the trailer harness and strip the ends on all minus the white ground wire.
2. Twist end of each wire tightly with pliers (*Note: The ground wire [white] will have a 5/16” Wire Ring Connector already attached*).
3. Push the three wires through the middle top hole of the tail light bracket on fender.

4. Gently push wire into the color-coded hole on the top row that is stamped on housing on the back of the taillight.
5. Gently pull on each wire to make sure that it is seated properly.
6. Place light onto mounting bracket on each fender.
7. Install taillight housing on brackets using nuts and lock washers provided. Be sure to attach the ground wire with wire ring connector to one of the tail light bolts. *Note: The white ground wire can be placed on either post.*

Congratulations! The trailer assembly is now complete and ready for towing.

About your Trailer Axle

Kendon Premium Trailers utilize torsion suspension, which is completely self-contained within the axle tube. It attaches directly to the trailer frame using brackets, which are an integral part of the axle assembly. Compared to a leaf spring system, the torsion-style suspension axle provides superior suspension characteristics through the unique arrangement of a steel bar surrounded by four natural rubber cords encased in the main structural member of the axle beam. The wheel hub spindle is attached to a lever, called the torsion arm, which is fastened to the rubber-encased bar. As a load is applied, the bar rotates causing a rolling/compressive resistance in the rubber cords. This action provides the same functions as a conventional leaf spring axle with several operation advantages including independent suspension.

Dual Rail Transport - Carrying One or Two Large Motorcycles:

Yes, you can safely and easily haul one or two motorcycles on the Dual Rail trailer because of the independent suspension offered by the torsion axle. Even if you are transporting only one motorcycle the independent suspension guarantees safe comfortable operation. When transporting a single bike on one of the outer rails, we recommend loading the bike on the side which you can see the bike best from your rearview mirror. *Note: If you do not feel comfortable transporting one bike on either side of the trailer, we offer an optional center rail accessory to transport one bike in the middle of the trailer.*

Bearing Greasing Interval:

**CHECK AND GREASE BEARINGSEVERY 3-MONTHS OR 6,000 MILES.
REPACK AT LEAST ONCE PER YEAR. HIGHER MILEAGE USE MAY
REQUIRE MORE FREQUENT INSPECTIONS.**

1. Remove rubber grommet from aluminum dust cap cover from hub end to expose zerk fitting.
2. Hook up grease gun tip to zerk fitting.

3. Pump grease slowly until you feel resistance and see new grease come out. Do not overfill excessively, inside bearing seal may push out causing grease to escape and spill onto inner wheel.
4. Stop pumping and clean off excess.
5. For detailed instructions on repacking bearings please refer to the "Care and Maintenance" section.

Hitch Information

Kendon Premium Series trailers are built to receive a 2" ball in the coupler. Some newer vehicles are sold with 1- $\frac{1}{4}$ " receivers. Please ensure that your vehicle will accommodate a hitch and ball to tow a trailer with a 2" ball in the coupler.

Hitch Height and Attaching Trailer to Vehicle

You must use a Class 2 or greater hitch on your towing vehicle. Please consult a trailer hitch expert to ensure that you have purchased the correct class of hitch. Please purchase a hitch for your towing vehicle that makes the bed of your Kendon trailer level when in tow. Generally, for Premium Series trailers the distance from the ground to the top of the ball on the hitch will be approximately **19" to 21"**. But, this may vary depending upon the load carried in the towing vehicle and the weight of the motorcycles(s) being towed. When the trailer is level in tow, the tongue weight will be approximately 10% to 15% of the total load weight.

Hitching the trailer to your vehicle is usually a one-person job, but it is easier and safer if someone helps.

1. Back your tow vehicle as close as possible to the trailer. It's easier and safer to do this than to pull your trailer to your car or truck.
2. Release the coupler-locking device on the trailer.
3. Raise the front end of the trailer coupler directly over the hitch ball, and then lower it until it is seated on the hitch ball, covering it completely. Check under the coupler to ensure the ball clamp is **BELOW** the ball, and not riding on top.
4. Latch the coupler to the hitch ball. Make sure it is locked in place by lifting the trailer tongue. If the coupler comes loose from the ball, unlatch it and repeat from step #2. If secure, we recommend locking the coupler using Kendon's coupler lock (Part # KL064). Refer to the diagram below for an illustration of the coupler latch in the closed position.

Coupler Latch in Properly Closed Position



5. Attach both safety cables to an appropriate place on your hitch. If the coupler were to detach from the ball, proper application of the safety cables would keep the coupler from hitting the ground. The best method of attachment would be to cross the two cables underneath the coupler. Replacement safety cables are available through Kendon.
6. Connect the 4-pin flat trailer wiring harness connector to the lighting system of your tow vehicle. Check to determine that turn signals, brake lights and running lamps are operational. Never use the trailer if the wiring connections for lighting are not properly working. Refer to the enclosed wiring diagram for additional wiring information. The electrical connector is a flat four-prong connector.
7. When towing it is important that the trailer bed is perfectly level (parallel to the road surface) for correct tracking. The ball height is measured from the ground, on a level surface, to the top of the trailer hitch ball. Failure to follow the above may result in an accident while towing. The top of the ball hitch must rise to approximately 19" to 21" above the ground with the vehicle loaded for the Premium Series Single, Dual and 3-Rail transports.
8. Inspect tires for excessive wear, tears, or any damage before any use. In addition, the tire should be properly inflated to the manufacturer's specifications when cold (we recommend approximately 45 to 50 psi). Improper tire inflation will affect safe usage of this and all trailers. Do not over-inflate the tire or exceed the maximum capacity of the wheel. Wheel nuts and bolts should be torqued before first road use, after 50 miles and after each wheel removal. Check and re-torque after the first 10-25 miles and again at 50 miles. Check periodically thereafter. Proper wheel torque specifications should be 90-120 foot-pounds using a proper torque sequence. Higher mileage use requires more frequent inspections.

Proper Ramp Attachment and Loading/Unloading

After your trailer has been properly attached to the tow vehicle, as previously described, you must fold out the back half of the trailer to load motorcycle(s). Make sure the area you are working in is level and both the surface area and trailer are dry to avoid slipping.

Each trailer is equipped with one or multiple loading ramps depending on the model. On standard Single, Dual and Combo push-up operation models you will find the ramp secured to the underside of the rear section. On Ride-Up models you will find it attached to the underside of the rear section and/or the deck of the trailer. On the SXS/ATV/Utility Trailer trailers you'll find two ramps secured next to the front guardrails. Refer to the separate Premium Series model specific instructions for ramp location(s) and use (if applicable).

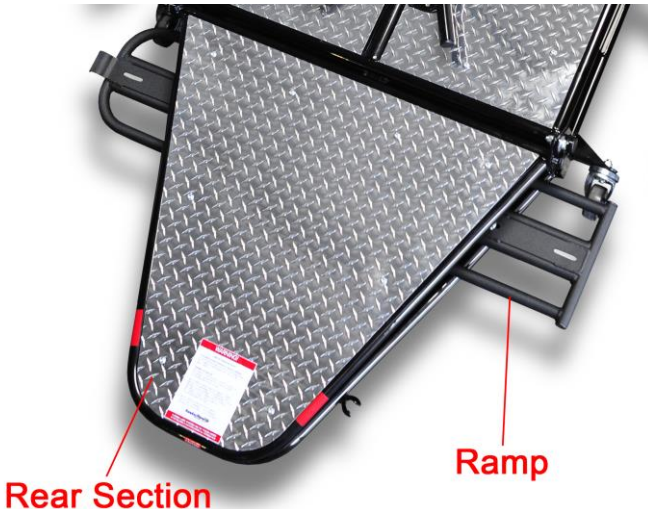

Make sure the ramp is properly secured to the trailer prior to loading the motorcycle(s). Never attempt to ride your motorcycle(s) up or down the loading ramp unless you have a Ride-Up specific trailer.

Attach ramp to rear of trailer. Look directly at the rear section of your trailer, you will see open slots that line up with the ramp hook(s). These slots are also marked with red warning decals. The ramp hook(s) must go into these slots only.

- Hold ramp at approximately 45 degree angle (ramp hook(s) down, rear of ramp is up at approximately 45 degrees)
- Line up ramp hook with slots on the rear section of the trailer

- Insert ramp hook into slots (hook should look like a spoon facing up)

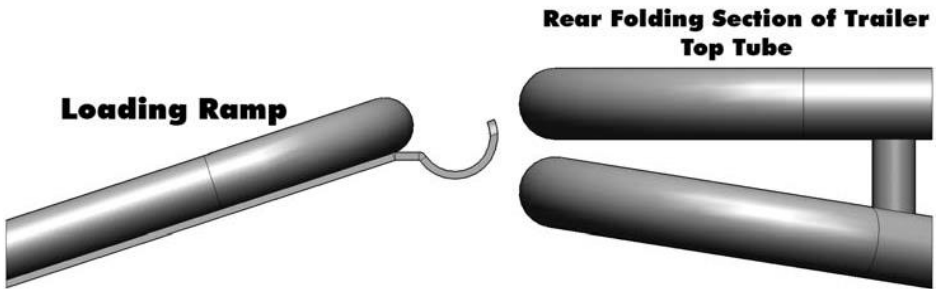

- Lower the back of the ramp to the ground surface
- Ramp should pivot to the ground with no resistance

NOTE: If ramp does not freely fall to the ground and “hangs up,” you do not have the ramp hooks properly inserted into your trailer.

⚠ WARNING

Because of the many designs and weight of motorcycles, it is the owner's responsibility to determine if assistance is needed to load or unload your particular equipment. However, we believe that in the interest of safety, help of at least one spotter should be acquired prior to any attempt to load or unload motorcycles.

The Gross Vehicle Weight Rating (GVWR) of your trailer should never be exceeded. Gross Vehicle Weight Rating is the total weight of the trailer and all equipment carried by the trailer. All Kendon trailers have a true trailer load capacity; which means you do not have to factor in the weight of the trailer into the maximum load you can carry. The maximum load you may place on a specific Kendon trailer is as follows:

- Premium Series Single/Single Ride-Up: 1,000 pounds U.S.
- Premium Series Dual/Dual Ride-Up: 2,000 pounds U.S.
- Premium Series 3-Rail/Combo Trailer: 1,500 pounds U.S.
- Premium SXS/ATV/UTV Utility Trailer - 2,000 pounds U.S.

If you have any questions concerning your particular application please call Kendon for advice.

Motorcycle(s) should be properly secured to the trailer with Kendon locking ratchet tie-down straps. Motorcycle(s) being transported must have at least

four tie-down locations as to triangulate the system to ensure stability during transportation. It is **MANDATORY** that the following four locations be used:

- A. Front Tie-Down Procedure - In the triple tree or fork area of your bike attach two ratchet tie-downs to the most forward tie-down area on the trailer (outer-ear/outrigger). If you are unable to reach the area on your bike with the tie-down hook, you can wrap a soft-tie around; which can also prevent scratching and/or damage. Tighten the ratchet tie-downs so that the front suspension of the motorcycle is compressed to at least 75% of total travel. This is critical to ensuring the motorcycle remains stable on the trailer. The Compression of the front suspension of your motorcycle should result in very little additional compression being possible. As the trailer is towed, the motorcycle should not further compress its suspension on account of its own weight. Otherwise tie-down hooks could become disengaged, resulting in the motorcycle becoming unattached.

- B. Rear Tie-Down Procedure - From a solid frame attachment point on the motorcycle (e.g., the rear swing-arm or suspension area) attach two tie-downs forward to mid-tie-down area (forward of the trailer axle location) in the center of the trailer (on Dual/3-Rail/Combo trailers) and on the axle hoops on the outside. If you are unable to reach a solid frame area of your bike with the tie-down hook, you can wrap a soft-tie around; which can also prevent scratching and/or damage. These locations provide the stabilization and triangulation needed to secure the bike. The critical factor in securing the rear section of the motorcycle to the trailer is that the rear tire on the motorcycle locks the rear section of the trailer in place. This is due to the rear motorcycle tire pressing down on the rear folding section of the trailer, but the tie-down straps are secured to the trailer **IN FRONT** of the trailer axle so the weight is pulled forward and down. If improperly tied down, the rear section can also bounce and break at the hinges.

Please refer to the diagrams below for recommended tie down locations.

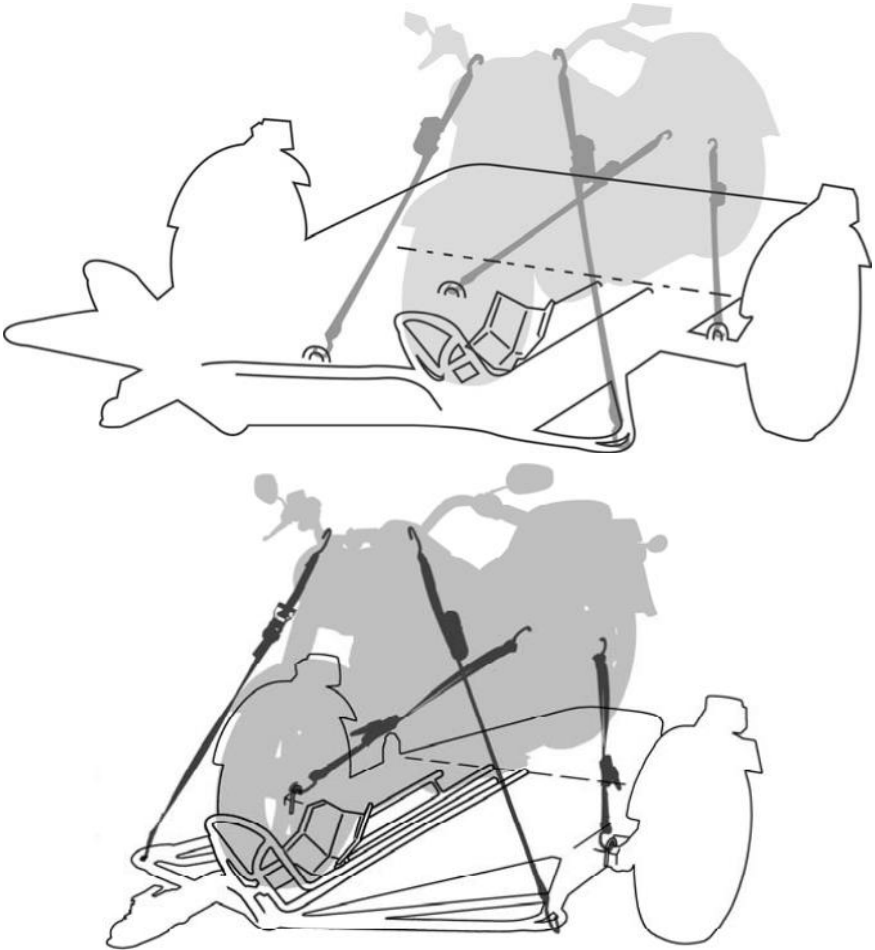

⚠ WARNING

Failure to properly tie down motorcycle(s) could result in serious injury, property damage and/or death. If you have any hesitation and/or questions about safely securing your vehicles to the trailer, please stop and contact Kendon immediately.

It is the user's responsibility to ensure that the motorcycle(s) are properly secured to the trailer for transport. Because of the variety of terrain and variable factors involved, the user must use common sense when securing the load. Again, if you have ANY doubts, please call Kendon for advice.

We recommend always using Kendon locking ratchet tie-down straps. They are of exceptional quality and are designed for our trailers. There are many

other tie-down strap manufacturers in the marketplace, but we do not believe you should compromise the integrity of your bike tie-down security system. These items can be acquired directly from Kendon by phoning our order desk at 800-847-8618 or on our website www.KendonUSA.com.

NEVER ride your motorcycle(s) onto the trailer under power unless you have a Ride-Up specific trailer. We recommend staying on the ground while loading the bikes. If this cannot be accomplished safely alone, we suggest you seek help from another individual. Walk your motorcycle onto the trailer.

Our Kendon "wheel chocks" can enable a single person to load a bike easily. All 2003 and newer motorcycle trailer models come equipped with Wheel Chocks. If you have an older model trailer, our wheel chocks can be purchased from us for easier loading.

The Wheel Chock is the device that flip-flops back and forth into the "Open" or "Closed" position on the motorcycle rail. It is open when the rear section of the Wheel Chock is down so that the motorcycle can be wheeled into place on the motorcycle rail. It is closed when the motorcycle front wheel is fully engaged in the wheel chock and the front of the Wheel Chock is lying down flat against the motorcycle rail. The Wheel Chock must be in the open position before the motorcycle is wheeled onto the trailer platform. After walking or riding (Ride-Up models only) your motorcycle up the ramp and onto the trailer platform, allow the front wheel of your motorcycle to lock securely into the Wheel Chock system on the motorcycle rail assembly. When the motorcycle is correctly secured in the Wheel Chock it can stand by itself; there may be no need to hold the motorcycle upright, but **be sure to test this with a spotter as there are many different sizes of front wheels**. Now, you can securely tie down your motorcycle using Kendon heavy-duty ratchet-style tie down straps.

WARNING

Front Wheel Chock Position must be flipped into the "open" or "load" position with the rear section of the wheel chock flat on the trailer rail. Failure to have the front wheel chock in the correct position will cause the front wheel to hit an obstacle during the loading process resulting in a possible loss of balance and/or fall.

DO NOT transport bike using the wheel chocks **ONLY**. Secure the bike to the trailer with locking ratchet tie-downs, as per this owner's manual.

Ensure the wheel chock is in the open position before the motorcycle is loaded up on the trailer platform. The wheel chock is in the open position when the wheel chock is rotated towards the rear of the trailer and the rear section of the wheel chock channel lays flat on the trailer rail. Please refer to the following illustration for proper wheel chock

positions.

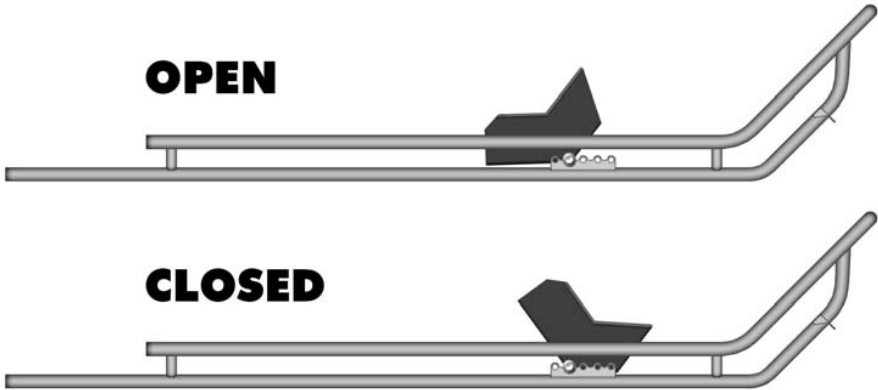

To load your bike onto a trailer with wheel chocks:

- A. Set the chock to the open position.
- B. Push or Ride (Ride-Up models only) bike onto the trailer and into the chock.
- C. Keep pushing bike forward until the bike chock teeters over into the closed position.
- D. The weight of the bike moving forward activates the closing of the chock.
- E. The front wheel is captured between the chock & the front of the motorcycle rail on the trailer bed.
- F. Detach the ramp(s) from the rear section of the trailer. Attach ramp(s) back on the trailer in the original position(s).

⚠ WARNING

Ramps must be properly mounted on the trailer with supplied mounting hardware firmly tightened down. Loose mounting hardware can cause a ramp to come off of the trailer causing serious damage or injury to following traffic. Owner assumes responsibility for properly securing ramps.

Remember; when it is time to unload your motorcycle(s) **BE CAREFUL** to stand back and release the tie-down straps **slowly** to avoid the motorcycle "jumping" since the suspension components are compressed. Sudden movement can cause the load to fall, which may cause injury, death and/or property damage.

To unload your bike from a trailer with wheel chocks:

- A. Attach ramps as instructed on pg. 12.

- B. Remove all four (4) tie-downs from vehicle.

The motorcycle will not easily roll back to unload due to the design and function of the front wheel chock.

When the trailer is loaded, the front wheel chock captures the front wheel of the motorcycle. To unload, you must get the wheel chock over its center point and then it will release.

- C. With the motorcycle Off and in Neutral, straddle the bike with both feet firmly on the trailer. Aggressively pull up and back while keeping your hand on the front brake lever (brake not applied), your motorcycle will ride up the wheel chock. At the peak grab your front brake so the bike does not roll back forward into the locked position. Now take one more pull rearwards while releasing the front brake and your front wheel will easily roll out of the wheel chock. Don't worry if you don't accomplish this on the first try. The bike will simply come back to rest in the wheel chock. It may take a few attempts until you learn this technique. It is also perfectly acceptable to get help and have someone help push the bike backwards to get out of the front wheel chock.
- D. Once out of the front wheel chock, continue to use the front brake to carefully and slowly back your motorcycle down off your trailer. Use at least one spotter to avoid the risk of losing your balance and dropping your bike.

Trailer Tactics

With a trailer in tow, you are operating a vehicle that is longer, heavier, and sometimes wider and taller than you may be used to so, you may have to make some compensating adjustments to your normal driving practices.

- Take a "Shakedown" Drive - Make at least one short trial run before your trip. It will help familiarize you with your trailer's operating characteristics. It will also let you know that the lights, brakes, etc. are working properly.
- Slow down - Moderate to slow speeds put less strain on your vehicle and trailer. Never drive faster than is safe for conditions, and never exceed the posted speed limit.

Note: *Kendon supplied "ST" Rated Trailer Tires have a speed rating of 75 MPH (Miles Per Hour). Please be sure to set the appropriate tire pressure as recommended by the tire manufacturer (Kendon*

recommends 45 to 50 psi for all trailers). **Never exceed the posted speed limit for cars/trailers.**

- Always allow extra time and space when both passing and stopping, especially since Kendon trailers are not equipped with brakes.
- Check your Rearview Mirrors - Doing this frequently will let you know that your trailer is riding properly. We recommend outside rearview mirrors on both sides of your tow vehicle.
- Swing Wide - You need to make wider turns and wider corners because you are towing a trailer.
- Pass with Extra Care and Watch for Wind - Passing will take more time since you are towing a load. Be prepared for sudden changes in air pressure and wind buffeting when large vehicles are passing from either direction. Slow down a bit and keep a firm hold on your steering wheel. Aim straight down your lane.
- Avoid Sudden Starts and Stops - This can cause skidding, sliding or jackknifing. Avoid quick stops while turning. Because we designed a trailer to fit within normal garage ceiling heights in the standing position, the tongue of the trailer is short. Therefore, extra caution should be used when backing to avoid jackknifing the trailer. Do not back up unless you can clearly see where your trailer is at all times.
- Always be Courteous - Signal your intentions to change lanes, turns, etc. since others need to know your driving plans.
- Never Tailgate - You should be at least one car and trailer length for each 10 M.P.H. of speed traveling. Three seconds should be a minimum distance.
- If a Problem Occurs, **DON'T PANIC!!** - Stay cool. Avoid jamming on the brakes, mashing the accelerator or sudden turns. Brake gradually and slowly to a complete and straight stop. If the trailer were to fishtail, back off the accelerator a bit. This could mean improper tongue weight - check your motorcycle(s) to determine if the load is properly secured and has not shifted. We recommend you stop to check your load after 5 or 10 miles and every 50 miles thereafter during your trip as tie-down straps can become loose and/or the load can shift.
- Make sure your ramps and spare tire are properly secured to the trailer after use and before towing.

- Never tow an empty trailer folded out. Fold the trailer at the hinge and secure the back half of the trailer to the front-half using the rubber latch as shown.



Trailer properly folded for transport when empty.

Storage of Your Kendon Trailer

All Kendon Stand-Up™ trailers are designed for compact storage when not in use. To prepare your trailer for storage, please safely remove all cargo and follow the steps below. If your trailer is equipped with accessory add-ons, such as stone guard or utility box, we recommend removing them before attempting to stand your trailer up for storage.

1. Once the trailer is empty, fold the back half (rear section) of the trailer up and forward towards the tongue.



2. Once the trailer is folded in half, secure the rear section to the front using the rubber latch attached to the trailer.

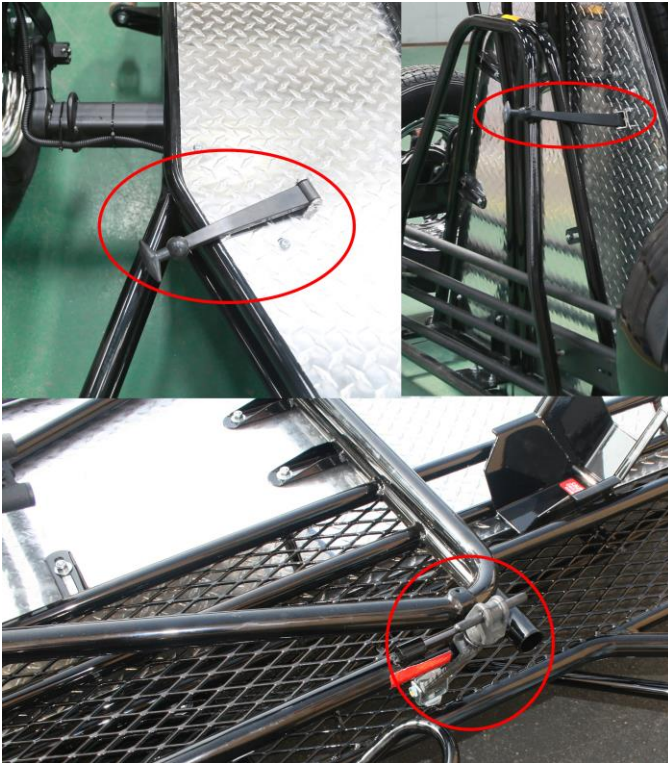

3. Disconnect the trailer from vehicle and roll it by the tongue to its storage location with weight on the street tires not the casters. Get the trailer as close to its final storage location as possible before standing-up. Lift properly and safely to avoid injury; Kendon recommends always having at least one spotter/helper.

4. Final storage area must be smooth and level. A good example would be a concrete floor in a garage. Double check to ensure the back half of the trailer is secure using the rubber latch. Lift the tongue of the trailer upward and the rear of the trailer will rotate from the street tires onto the integrated casters. Once the trailer is on the casters it may be slowly rolled to its final storage area. Again, the surface must be smooth and flat with no slope. Failure to follow this instruction could cause the trailer to fall causing injury, death and/or property damage.

Note: If you're new to Kendon folding trailers, we recommend practicing the stand-up procedure with a spotter/helper on a non-skid type surface, such as a lawn or carpeted area. This will allow you to get a feel for the trailer dynamics and how the trailer reacts to different lifting techniques.

5. We recommend securing the trailer to the wall at its final storage location. This can be accomplished by securing the safety chain to an eye-bolt in the wall that would support the falling weight of the trailer. Please use best judgment when securing a trailer to a wall or other solid piece of framework.
6. Remember, should you have any questions, please call Kendon Industries directly at 800-847-8618 or 714-630-7144.

Care and Maintenance of your Kendon Premium Series Trailers

Care of diamond plate:

Aluminum diamond plate is beautiful, strong and lightweight. It is an engineered and designed choice by Kendon for those reasons. Diamond plate is only supported under the rails in line with the wheels of the motorcycle and certain areas for foot placement during ride-up loading; DO NOT stand or jump on unsupported areas between the rails.

DO NOT use harsh chemicals for cleaning. Use commercial motorcycle or automobile car wash detergents for cleaning and aluminum polish to keep its original beauty.

DIAMOND PLATE NOT WARRANTED AGAINST DENTING

 **WARNING**

Motorcycles must be firmly tied down with the front and rear tie-down points as explained in this owner's manual. Failure to properly tie down the rear section of motorcycle(s) can cause rear of bike to hop or move resulting in the rear wheel landing on unsupported diamond plate.

Hub Greasing/Repacking Bearings:

CHECK AND GREASE BEARINGS EVERY 3-MONTHS OR 6,000 MILES. REPACK AT LEAST ONCE PER YEAR. HIGHER MILEAGE USE MAY REQUIRE MORE FREQUENT INSPECTIONS.

Recommended Tools:

1. Socket Wrench with 1-1/2 4-Pin Castle Nut/Spanner Socket
2. 13/16" or 21 mm Lug Wrench (for 1/2" Lug Nuts – Chrome/Steel Wheels & Spare Tire), 11/16" or 17 mm Thin Wall Socket (for Aluminum Raceline Wheels)
3. 7/16" or 11 mm Combination Wrench
4. Torque Wrench
5. Rubber Mallet
6. Pliers
7. Flat Head Screwdriver
8. Marine Grease

Although not required, it is recommended to remove the entire hub to fully repack bearings with fresh grease at least once per year. Higher mileage use may require more frequent inspections.

Note: By simply adding grease to used and/or dirty bearings it will not clean the bearings. Adding grease simply flushes the existing worn grease and/or dirt deeper into the bearings and further spreads it out. We recommend repacking and cleaning bearings at least once per year..

Typical End Unit/Hub Assembly

Hub Components:

- (a) Hub
- (b) Spindle
- (c) Dust Cap
- (d) Hub Seal
- (e) Inner Bearing
- (f) Bearing Races
- (g) Outer Bearing
- (h) Flat Washer
- (i) Tang Washer
- (j) Castle Nut
- (k) Rubber Grommet

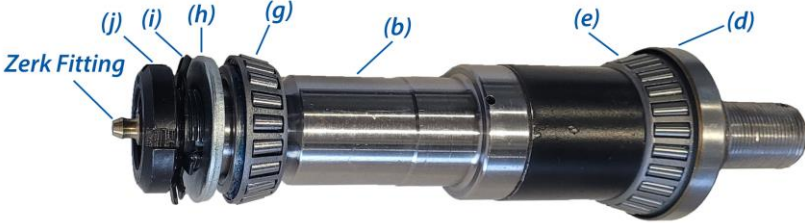

1. Remove wheel from hub assembly.
2. Remove aluminum dust cap cover(c) from hub end using a flat head screwdriver and/or rubber mallet.

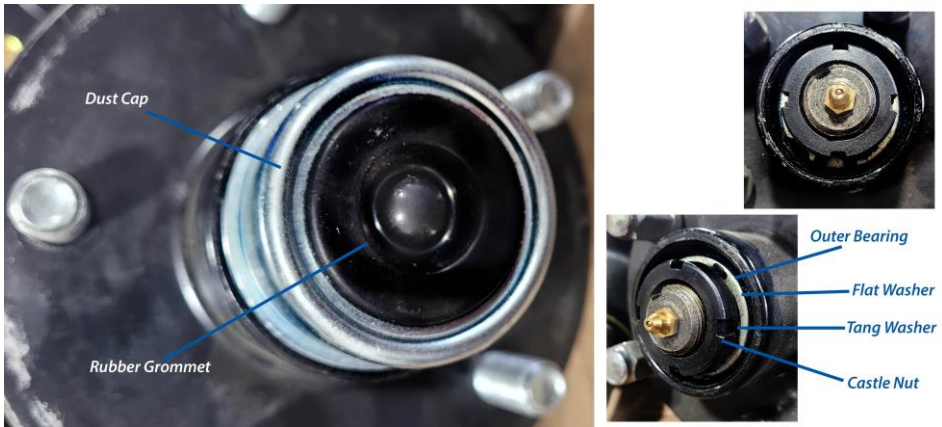

3. Straighten and remove tang washer (i), then remove the castle nut from spindle using pliers and castle nut/spanner socket/wrench.
4. Remove washer and outer bearing from spindle.
5. At this point you will be able to pull the entire hub assembly off of the spindle that is still attached to the torsion arm of the axle (*Be careful as bearings will come out with the hub*). If you choose to only add additional grease and not fully repack your bearings, please continue with step 5a below. Otherwise, continue with step 5b.
 - a. Using a grease gun, pump lube grease into the space between the spindle and the hub. Old grease will come out as you pump in new grease. Stop pumping and clean off excess. Do not overfill excessively as the bearing seal may push out and/or become damaged causing grease to escape and spill onto the inner wheel. Grease the outer bearing with fresh grease. When done, proceed with step 14.
 - b. Pull the entire hub assembly off the spindle; be careful as bearings will come out with the hub. Continue to step 6.
6. Remove outer bearing with race and set aside on clean rag or newspaper along with castle nut, tang washer, washer and dust cap.
7. Remove the inner, or rear, bearing, race and seal by inserting a block of wood into the hub and tapping the block of wood along the rim of the bearing with a rubber mallet. If the seal is stuck or rusted in the hub, use a little lubricant, such as WD-40, to help loosen the seal.
8. Clean the grease from bearings, seal(s), races, grease/dust cap, hub and spindle with a brush and/or rag using a cleaner of your choice.

The cleaner that you use should be suitable for dissolving oil, grease, and removing dirt from steel, plastic and rubber surfaces.

Note: If you select a water-based cleaner, be sure to dry your bearings immediately and re-apply grease to prevent any rust. Some cleaners that are water or oil based may leave slight residue, refer to the cleaner instructions for proper use.

9. Inspect bearings and seals for any damage or worn components. If they look suspect, replace them immediately (Outer bearing replacement #: L44649, Inner Bearing #: L68149)
10. Coat the spindle and inside of the hub with fresh grease. We recommend using marine grease in the hub assembly.
11. Push and pack fresh grease into the bearings. Work your way from the wide to narrow side of the bearing, making sure to push the grease into the rollers, until the cage and rollers are filled.
12. Insert the inner bearing, race and seal back into the back of the hub and tap into place using a wood block and rubber mallet. Ensure the inner bearing's tapered edge is facing into the hub.
13. Install the hub and bearings back onto the spindle.
14. Insert the outer bearing and race onto the spindle and into the hub with the tapered edge of the bearing facing into the hub.



15. Grease the washer, castle nut and tang washer and thread them back onto the spindle. Be sure to torque the castle nut to approximately 50-foot pounds. This torque range will allow you to align the spaces on the castle nut with the tang washer. Make sure hub spins freely, if tang washer cannot be aligned back off the castle nut. Bend both ends of the tang washer to keep it from working its way out.
16. Tap the dust cap/grease cap back into place using a rubber mallet.

17. Re-install the wheel using the procedure described on pg. 8.

Care of Powder Coated Frame and Components:

Powder Coating provides a beautiful, high-quality, durable finish and is the preferred coating choice for all Kendon trailers. Powder coat provides good resistance to scratches, chipping, moisture, corrosion, ultraviolet light, and other weather conditions. While powder coat can last a very long time, when properly maintained, it is not completely prone to fading, corrosion and diminished protection of the steel it coats over time. As the saying goes, "nothing lasts forever." However, you can take some preventative maintenance steps to ensure that your powder coated frame and components last for many years.

Just like your car and motorcycle(s), Kendon trailers have to be periodically cleaned to keep them in tip-top shape. When you're taking the hose to clean your motorcycle, take an extra few minutes to also wash your trailer. You can even use the same washing products of your choice on the trailer as on your bikes. After you have washed the trailer, make sure it's completely dry and inspect it for any corrosion/rust.

Rust is steel's worst enemy and your trailer is mainly composed of steel. Take time to thoroughly inspect your trailer for any rust that may have developed. Surface rust can be easily touched up with scotch brite or a brush and touch up paint. We offer touch up paint that exactly matches the color of your powder coat. If you're in a pinch you can also pick up some Krylon Fusion or Rust-Oleum Gloss Black paint at your local hardware store. Left untreated, rust will continue to corrode powder coat and steel. The trailer then will develop bubbles in the coating, cracks, peeling and eventually it will rust through the steel and break.

Word of Caution: Rust spreads FAST! It spreads especially fast in high salt and moisture environments. Keep your trailer in the garage? It's not completely isolated from moisture, the elements and rust. Left untreated, rust can continue to spread even in well isolated areas; as long as some moisture and oxygen is around, rust can continue to spread and corrode your trailer.

Trailer Caster Care:

Kendon Premium Series trailer casters don't require very much maintenance other than an occasional re-greasing of bearings. This can be accomplished using the same grease as in your hubs or a liquid lubricant. Most casters can be easily removed and re-greased for lasting performance. We recommend using the trailer casters only on smooth garage type floor surfaces. These casters are not designed to "go off-roading" and will not roll very well on your

front lawn or cobblestones. Should you have any problems with your casters or need replacements, contact us at 800-847-8618 or info@kendonusa.com.

Trailer Coupler Maintenance:

The trailer coupler is a simple spring loaded latching mechanism. We recommend adding a little light grease or spray lubricant to the moving parts to prevent squeaking and surface rust. We also recommend a little grease inside of the 2" coupler so that the trailer ball moves freely and does not chip the powder coat on the underside of the coupler.

Exposed Bolt/Nut Maintenance:

Although most of the hardware that is used in the trailer assembly contains some type of coating, whether it be zinc, Teflon or similar, we recommend using anti-seize or light spray lubricant to prevent the threads of bolts and nuts from sticking and/or corroding over time. The best time to do this type of maintenance is after washing the trailer as described in the "Care of Powder Coated Frame" section.

Kendon Premium Series Trailer Replacement Parts:

Most, if not all, parts and components on your Kendon Premium Series Trailer can be rebuilt or replaced. We carry a wide assortment of replacement parts for your trailer so you don't have to go on a hunting quest to locate them on your own. Below you will find a list of the most common replacement parts along with standard sizes and/or part numbers for replacement. If you have trouble locating a part or have questions please give us a call at 800-847-8618 or send us a note at info@kendonusa.com and we will be happy to help.

Outer Bearing:	L44649
Inner Bearing:	L68149
Rear Tail Light Bulb (large):	1157
Rear Tail Light Side Marker Bulb (small):	924
Trailer Tire:	ST175/80R13 Radial
Trailer Wheel/Rim:	13X4.5 - 5 on 4.5 neutral/zero offset
Hub/Bearing Grease:	Lucas Oil Marine Grease
Black Powder Coat:	Cardinal T009-BK12 Or Dupont Bike Black PFB 603 S9
Powder Coat Touch Up Spray Paint:	Krylon Fusion Gloss Black Or Rust-Oleum Gloss

	Black (rust inhibiting)
Lug Nuts:	1/2"-20
Spare Tire Lug Nuts:	1/2"-20 open end
Electrical Connector:	4-Pin Flat
Trailer Coupler:	2" fits 2" ball

Note: Parts listed in inches; may require metric equivalent on some models.

Trailer Torque Specifications

Wheels:	90 to 120 Ft./Lbs.
Spindle Castle Nut (Axle Side):	50 Ft./Lbs.

Trailer Wiring Diagram:

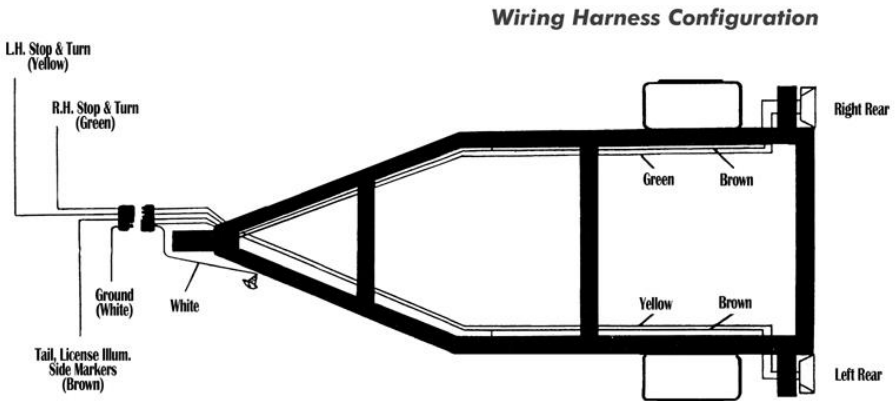

Disclaimers:

Krylon, Fusion, Rust-Oleum, Scotch-Brite, Teflon, Lucas Oil, Red N' Tacky and WD-40 are the registered names and/or trademarks of their respective trademark holders. Kendon Industries, LLC is not in any way associated with or endorsed by these brands. Product names, logos, brands, and their trademarks featured or referred to within this Owner's Manual are the property of their respective trademark holders. These

trademark holders are not affiliated with Kendon Industries, LLC, our products, or our web site. They do not sponsor or endorse our materials.

The Kendon name and all trademarks and logos displayed in this manual are owned or used under license by Kendon. These trademarks include, but are not limited to, product brand names, product model names, slogans, and logos and emblems (e.g., Kendon®, Stand-Up™, MotoLift™, Go! Series™). The unauthorized use of any trademark displayed in this manual is strictly prohibited.

Copyright © Kendon Industries, LLC. All rights reserved. This manual, including all content and materials, is protected by worldwide copyright laws and treaty provisions whether or not a copyright notice is present on the materials. All text, images, graphics, and other materials in this manual are subject to the copyrights and other intellectual property rights of Kendon and its licensors. You agree to comply with all copyright laws worldwide in your use of this manual and to prevent any unauthorized copying of the materials. Except as expressly provided herein, Kendon does not grant any expressed or implied rights to you under any patents, trademarks or copyrights.

This manual and all the information it contains is provided for information purposes only on an “as is” basis and could include technical, typographical or other errors. In certain areas, the information provided may represent an opinion or judgment. Kendon, information providers, and their agents make no warranties, representations, or guarantees of any kind, express or implied, including but not limited to, accuracy, currency, or completeness of this manual, the information, materials, content, availability, and products. To the extent permitted by applicable law, Kendon disclaims all warranties, expressed or implied, including but not limited to, implied warranties of merchantability and fitness for a particular purpose. Kendon is not responsible for the content of any web site, document, or other source that is linked to or referenced to this manual and is not directly or indirectly implying any approval, endorsement or affiliation with any linked source.

Kendon reserves the right to change, modify, suspend, discontinue or permanently cancel this owner’s manual or portions thereof without any prior notice to you, including but not limited to product specifications or instructions, at any time and from time to time without notice and without incurring any obligations.

Trailer Frame Limited Warranty

The frame assembly on all Kendon Trailers is warranted against defects in manufacture or design for a period of one (1) year from date of original purchase. This is a LIMITED WARRANTY and this written warranty is offered in lieu of all other warranties express or implied, except as may be required by law. In order to be eligible for warranty service, the “Product Warranty” Registration Card received with the trailer must have been completed and submitted to Kendon by the customer. **If you did not receive a Product Warranty card, please contact us at 800-847-8618, 714-630-7144, info@kendonusa.com or visit www.KendonUSA.com/registration.** To request warranty repairs, the trailer must be returned to Kendon, freight prepaid, with an RGA (Return Goods Authorization) number and copy of the original purchase receipt. Should the trailer need to be returned to Kendon for repair, the Customer is responsible for all

shipping costs to and from Kendon Industries LLC, 2990 E Miraloma Ave., Anaheim, California 92806. This warranty is not transferable and may be claimed only by the original purchaser of the trailer. This limited warranty becomes null and void in the event that **any** customer modifications are made to the trailer. This limited warranty provides repair or replacement to the frame only at Kendon's discretion. This Limited Warranty covers no consequential damages, or normal wear and tear. In the event of any dispute regarding this Limited Warranty between Kendon and the customer or any other party, each party shall bear their own legal costs and fees. Please refer to the Product Warranty Card for further details.

Trailer Axle Limited Warranty

The trailer axle warranty is a LIMITED WARRANTY, extended to the original purchaser only, against defects in material or workmanship for a period of one (1) year from the date of original purchase. THIS WARRANTY IS EXCLUSIVE & IN LIEU OF ALL OTHER WARRANTIES EXCEPT THAT OF TITLE, WHETHER WRITTEN, OR IMPLIED, INFACOR INLAW. A warranty period of one (1) year is extended on the torsion axle suspension, exclusive of hubs, drums, brakes, bearings and seals which are covered for a period of six (6) months from the date of purchase.

To obtain warranty service, please send the following information to **warranty@kendonusa.com**.

1. Name and mailing address of purchaser.
2. Proof of date of purchase.
3. Number of miles.
4. Model, year and serial number of axle (if available).
5. Model and VIN number of trailer.
6. Description of the defect.
7. Any pictures or additional information.

This warranty does not extend to:

1. The connecting of brake wiring to the trailer wiring or trailer wiring to the towing vehicle wiring.
2. The attachment of the running gear to the frame.
3. Hub imbalance or any damage caused thereby.
4. Parts not supplied by Kendon.
5. Any damage whatever if caused by or related to any alteration of the axle.
6. Use of axle assembly on unit other than that to which it was originally mounted.
7. Normal wear.
8. Alignment.

This warranty does not cover defects caused by:

1. Improper installation.

2. Damage (not resulting from defect or malfunction) while in the possession of the customer).
3. Unreasonable use (including failure to provide reasonable and necessary maintenance).
4. Improper wheel nut torque.

The exclusive remedy offered under this warranty is repair or replacement of a covered defect and Kendon shall determine whether repair or replacement is appropriate. Kendon shall not be liable for any incidental or consequential damages, including any towing fees, hotel bills, telephone calls and meals for breach of any express or implied warranty on the running gear.

Some states do not allow the exclusion or limitation of incidental or consequential damages, so the above limitation or exclusion may not apply to you. This warranty gives you specific legal rights and you may also have other rights which vary from state to state.

Inquiries regarding this warranty should be sent to or emailed to the address(es) below:

Kendon Industries, LLC
Attn: Warranty Department
2990 E Miraloma Ave.
Anaheim, CA 92806
Toll-Free: 800-847-8618
Tel: 714-630-7144
Fax: 714-630-7132
E-Mail: warranty@KendonUSA.com

Wheel & Tire Warranty and Information

The original manufacturer of the wheels and tires used on the trailer provides Wheel and Tire Warranties. Please refer to the supplied literature on the wheels and tires received with the trailer or contact Kendon directly to be referred to the particular correct manufacturer in regards to your wheels and tires.

All Premium Series Trailers are equipped with ST175/80R13 Radial Tires with Steel Chrome Plated Rims/Wheels and/or Aluminum Raceline Wheels, or neutral, or zero (0), offset. The speed rating for all ST tires is 70 MPH. Never exceed the posted speed limit. It is the customer's responsibility to maintain proper tire inflation and maintenance as recommended by the wheel/tire manufacturer.

Thank you again for purchasing our Kendon Product. If you have any questions on the proper use of this trailer please contact Kendon directly at 714-630-7144 or info@KendonUSA.com.

Ride safe
Trailer safe

Kendon Industries, LLC

2990 E Miraloma Ave.
Anaheim, CA 92806
714-630-7144 Telephone
714-630-7132 Facsimile

info@KendonUSA.com
www.KendonUSA.com

facebook.com/kendonusa
instagram.com/kendonindustries
TikTok @kendonindustries

NOTES

NOTES

WARNING

WARNING: Serious injury, death and/or property damage could result through improper use of this product, including crushing or severing type injuries.

WARNING: Thoroughly read and understand all instructions and owner's manual(s) before using the trailer.

WARNING: For Adult Use Only. Keep children away from trailer at all times.

WARNING: You must check to ensure that the front wheel chock on the trailer will not contact the bottom rear of your front fender, fairing or other parts of your motorcycle **BEFORE** loading.

WARNING: Trailer should only be loaded and unloaded on a stable flat surface with the trailer properly connected to the tow vehicle.

WARNING: Properly attach the loading ramps as per this manual's instructions.

WARNING: The motorcycle must be loaded on the center loading ramp.

WARNING: Obey trailer cargo capacity limits.

WARNING: There is an inherent risk in the loading and unloading process. Failure to load your vehicle properly could result in serious injury and or property damage. Load and unload at your own risk.

WARNING: Ramps cannot be interchanged. Right and Left ramps are not constructed to hold the weight of a vehicle and should never be used as a loading ramp for any vehicle. Right and Left ramps are for rider footing during the loading and unloading process.

WARNING: Never use ramps without both ramp pins fully engaged as instructed as this will cause the ramp platform to become unstable.

WARNING: Ramps must be properly secured to trailer prior to towing.

Trailer owner is responsible for complying with all the recommended procedures in this instruction manual. Use at your own risk. Kendon is not responsible for injury, liability, property damage and/or any consequential damage(s) caused by the misuse of this product.

This page intentionally left blank

Stand-Up™ Trailer Parts & Accessories



Kendon Trailer Cover
CVR107, CVR207,
CVR507, CVR305



LED Tail Light Kit
LEDTLK



**Crank Down Swivel Jack
Stand**
TSJS



**Aluminum Wheel and
Radial Tire Kits**
HPRTWK13



13" Spare Tire
BB206NR



Accessory Tie-Downs
TDK107 / TDK207



Optional Center Rail
OCD207



Coupler Lock
KL063



**Full Range of
Replacement Parts**

Visit us at www.KendonUSA.com for product updates, new products, and support.



NO PART OF THESE INSTRUCTIONS MAY BE COPIED AND/OR REPRODUCED WITHOUT THE WRITTEN PERMISSION OF KENDON INDUSTRIES, LLC. ALL PART NUMBERS, DIMENSIONS AND SPECIFICATIONS IN THESE INSTRUCTIONS ARE SUBJECT TO CHANGE WITHOUT PRIOR NOTICE.

Model Specific Owner's Manuals

In addition to the Premium Series Trailer Owner's Manual, please be sure to read and follow the instructions in the model specific Owner's Manual for your Kendon Stand-Up™ trailer. Scan the QR code below for your specific model to download the Owner's Manual.



Dual Ride-Up SRL Stand-Up™ Trailer Owner's Manual



Single Ride-Up SRL Stand-Up™ Trailer Owner's Manual



Utility/SxS Stand-Up™ Trailer Uncrating and Assembly Instructions



Trike/Spyder Ride-Up SRL Stand-Up™ Trailer Owner's Manual

PRODUCT WARRANTY REGISTRATION

Congratulations on your new Kendon purchase. You now own one of the world's most innovative space-saving powersports products. Used properly, Kendon Stand-Up™ Trailers and Lifts will provide years and years of performance and reliability. In the event you have an issue with your Kendon product, please contact us for warranty claims.

Kendon Stand-Up™ Trailers: 1-year limited warranty*, 5-year limited axle warranty

Kendon Stand-Up™ Lifts: 1-year limited warranty

Register your Kendon product today:

-Ensure your product is covered by warranty

-Receive special offers and discounts via email

Register online at: www.kendonusa.com/registration

Or complete the form below and return to us by mail

**Three-year and Five-Year Kendon Factory Extended Warranty options also available.*

Visit <https://www.kendonusa.com/parts-accessories/> for details or to order.



cut along dotted line

Kendon Stand-Up™ Trailers & Lifts Product Warranty Registration

Product*: Trailer Lift Other: _____

Year: _____ Model: _____

Trailer VIN* (where applicable): _____ Purchase date*: _____

Purchased from*: Dealer Kendon Kendon online Other online

Your name*: _____

Address*: _____

City*: _____ State*: _____ Zip*: _____

Email*: _____ Opt out of email list

*all fields must be complete to register your Kendon product

KendonStand-Up™ TRAILERS & LIFTS

PRODUCT WARRANTY

Subject to the limitations set forth below, Kendon Industries, LLC warrants every Stand-Up™ Trailer and Stand-Up™ Lift to be free from defects in workmanship or material for a period of one year from date of purchase. The obligation of Kendon Industries, LLC is limited to repair or replacement (at the sole discretion and option of Kendon Industries, LLC) of parts or products found by Kendon Industries, LLC to be defective, provided buyer has given prompt notice in writing of such defect to Kendon Industries, LLC. The obligation of Kendon Industries, LLC is further conditioned on the right of Kendon Industries, LLC to examine and inspect the part or product to determine that the owner has not made any modifications or alterations to the product after manufacture. It is the owner's responsibility to maintain said products in a condition to allow Kendon Industries, LLC to inspect the product.

All products submitted to Kendon Industries, LLC for evaluation by Kendon Industries, LLC as to whether a warranty claim hereunder will be considered must be shipped to Kendon Industries, LLC with the freight prepaid by the customer. Additionally, all replacement and/or repairing parts are F.O.B. Kendon Industries, LLC 2990 E. Miraloma Ave., Anaheim, CA 92806 and the customer shall be responsible for transporting the product back to the customer after warranty service, if any, has been performed.

This warranty shall not apply to any product or parts that have been subject to abuse, misuse, negligence, or accident, or has not been operated in accordance with the instructions of Kendon Industries, LLC. Buyer/owner assumes all risk and liability for the proper use of the product.

Kendon Industries, LLC shall not be liable for incidental, consequential, special, or any other damages of any nature. The liability, if any, to buyer/owner or any other person, shall not exceed the amount received by Kendon Industries, LLC from the buyer for the product or parts on purchase. It is expressly agreed that this warranty shall be in lieu of any other warranty, express or implied. Any warranties of merchantability or fitness for any particular purpose, which has been implied by law, shall be limited to ninety days from the date of purchase.

There are no understandings or agreements between Kendon Industries, LLC and the buyer or user concerning the warranty that are not fully expressed herein. No acknowledgements, purchase orders, or other documents, which contain any terms or conditions other than the ones stated herein, shall be binding on Kendon Industries, LLC.

Should any portion of this warranty become void or not enforceable, it shall be severed from the remaining portion of the warranty, which shall remain in force.

Kendon Industries, LLC will not consider any warranty claims unless the warranty registration has been completed in full. Proof of purchase and purchase date may be required to file warranty claims.

Kendon Industries, LLC
2990 E. Miraloma Ave.
Anaheim, CA 92806
714.630.7144
www.kendonusa.com

FOR YOUR RECORDS

Purchase date: _____
Product type: trailer lift other
Model year: _____ Model #: _____
VIN: _____

PLACE
STAMP
HERE

KENDON INDUSTRIES, LLC
2990 E. MIRALOMA AVE.
ANAHEIM, CA 92806

OR REGISTER YOUR PRODUCT ONLINE AT www.KENDONUSA.com/REGISTRATION

If you believe that your vehicle has a defect, which could cause a crash or could cause injury or death, you should immediately inform the National Highway Traffic Safety Administration (NHTSA) in addition to notifying Kendon Industries, LLC.

If NHTSA receives similar complaints, it may open an investigation and if it finds that a safety defect exists in a group of vehicles, it may order a recall and remedy campaign. However, NHTSA cannot become involved in individual problems between you, your dealer or Kendon Industries, LLC.

To contact NHTSA, you may either call the Auto Safety Hotline toll-free at 1-800-424-9393 (or 366-0123 in Washington, DC area) or write to: NHTSA, U.S. Department of Transportation, 400 7th Street SW NSA-11, Washington, DC 20590. You can also obtain other information about motor vehicle safety from the Hotline.

WARRANTY FOR RACELINE WHEELS ONLY

Allied Tire and Wheel Limited Tire Warranty

2019

Allied Wheel Components Inc, ("AWC") hereby warrants that every new tire bearing the brand name of **Ameritrail** or **TreadStar** is free from defects in material and workmanship. AWC Limited Tire Warranty applies only to the original purchaser for two years from the date of purchase; the warranty is not transferable to any other vehicle or person. This warranty's conditions and policies supersede any previous warranty. Conditions and coverage's are subject to change at any time and without notice.

A tire's "useable tread life" is the original tread groove depth down to the treadwear safety indicator bars that are molded into the tire groove. The treadwear indicators are reached when only 2/32nds of an inch of tire tread remains. A tire has delivered its full useable tread life when its original new tire tread has become worn down to the treadwear indicators at 2/32" (1.6mm) at which point the tire will be deemed to have served its useful life and is not subject to warranty or adjustment for any reason. Tires become unsafe for use and must be replaced to avoid accident or injury when the tread depth remaining is 2/32" or less.

If an AWC tire fails due to a defect in workmanship or materials you will be entitled to a prorated allowance applicable to the purchase price of a comparable new AWC Tire or other brand marketed by AWC. This replacement tire allowance will be prorated and calculated by dividing the number of 32nds of useable tread remaining when the tire is presented for warranty replacement, rounding to the nearest 32nd of an inch, by the total number of 32nds of an inch of useable tread. The limited warranty does not cover and you will be responsible for the charges applicable for mounting the replacement tire, and applicable taxes for the warranty replacement tire when the tire fails due to defects in material or workmanship.

Exclusions:

1. The Warranty is void if the tire is lost and or not provided for inspection.
2. The Warranty is void if the tire fails due to damage from improper inflation pressure, exceeding the maximum speed limit, or overloading the tire beyond the maximum load capacity stated on the sidewall.
3. The Warranty does not cover incidental or consequential damages, including, but not limited to, lost time, inconvenience, loss of vehicle use, cost of towing or transportation, related property damage or consequential damages of any type or nature.
4. The Warranty does not cover mounting and balancing charges, freight charges or additional costs beyond original tire replacement.
5. The Warranty does not cover weather checking on tires more than two years old.
6. The Warranty is void if a covered tire is worn past last 2/32" of tread depth at any point on the tread contact surface.
7. Allied makes no expressed claims of expected tire wear. Variables that affect tire wear are driving conditions, load position, axle alignment, and tire inflation pressure
8. The Warranty **DOES NOT** apply to the following:
 - (a) Tires used in racing or competition
 - (b) Tires subjected to road hazards (nails, glass, other foreign objects and natural/man made obstacles) overloading, under-inflation, improper mounting and fitment to incorrect rim, purposeful abuse or chemical contamination.
 - (c) Tires, which have been patched, plugged, or repaired or into which liquid balancers or sealants have been introduced.
 - (d) Cosmetic irregularities
 - (e) Any alterations made to the original tire or tread pattern.
 - (f) Self mounted tires. To avoid accidents, injuries and damage to the tire, a trained professional should only mount tires.

To obtain warranty adjustments or warranty information contact your AWC dealer or call AWC's Product Service Department at **1-800-529-4335** or fax to **1-714-893-4190**.

Claims must be made within 30 days of discovery of defect, Allied reserves the right to inspect all products before making adjustments.

THERE ARE NO WARRANTIES EITHER EXPRESSED OR IMPLIED, INCLUDING THE IMPLIED WARRANTIES OF MERCHANTABILITY AND FITNESS FOR A PARTICULAR PURPOSE, WHICH EXTEND BEYOND THE DESCRIPTION ON THE FACE THEREOF. ALLIED SHALL NOT BE LIABLE FOR ANY INCIDENTAL OR CONSEQUENTIAL DAMAGES. NO REPRESENTATIVE OF ALLIED WHEEL COMPONENTS, INC. HAS AUTHORITY TO MAKE ANY REPRESENTATIONS OR PROMISES EXCEPT AS STATED HEREIN.

This warranty provides specific legal rights. Other rights may vary from state/province to state/province.

Disclaimer: Every effort has been extended to assure the accuracy of this information. Should an error exist, Allied Wheel reserves the right to change or correct said error without notice