

***Kendon* Stand-Up™** **TRAILERS & LIFTS**

KENDON STAND-UP™ MOTORCYCLE LIFT OWNER'S MANUAL



KENDON INDUSTRIES, LLC
1672 Sierra Madre Circle
Placentia, CA 92870 USA
Tel 714-630-7144 • Fax 714-630-7132

www.KendonUSA.com

Rev. 032619

WARNING

- WARNING:** Serious injury, death and/or property damage could result through improper use of this product, including crushing or severing type injuries.
- WARNING:** Thoroughly read and understand all instructions and owner's manual(s) before using the lift.
- WARNING:** For Adult Use Only. Keep children away from lift at all times.
- WARNING:** You must check to ensure that the front wheel chock on the lift will not contact the bottom rear of your front fender, fairing or other parts of your motorcycle **BEFORE** loading.
- WARNING:** Lift should only be loaded and unloaded on a stable flat surface with the lift front feet properly rotated with the flat surface facing the ground.
- WARNING:** Properly attach the loading ramp as per this manual's instructions.
- WARNING:** Obey lift capacity limits.
- WARNING:** There is an inherent risk in the loading and unloading process. Failure to load your vehicle properly could result in serious injury and or property damage. Load and unload at your own risk.

Lift owner is responsible for complying with all the recommended procedures in this instruction manual. Use at your own risk. Kendon is not responsible for injury, liability, property damage and/or any consequential damage(s) caused by the misuse of this product.

⚠ CAUTION**LOADING**

Properly attach the loading ramp as per this manual's instructions.

Ensure motorcycle fender, fairing or other parts clear lift frame and wheel chock when loading and unloading.

Ensure the wheel chock on the lift rail is in the open position (pg. 16).

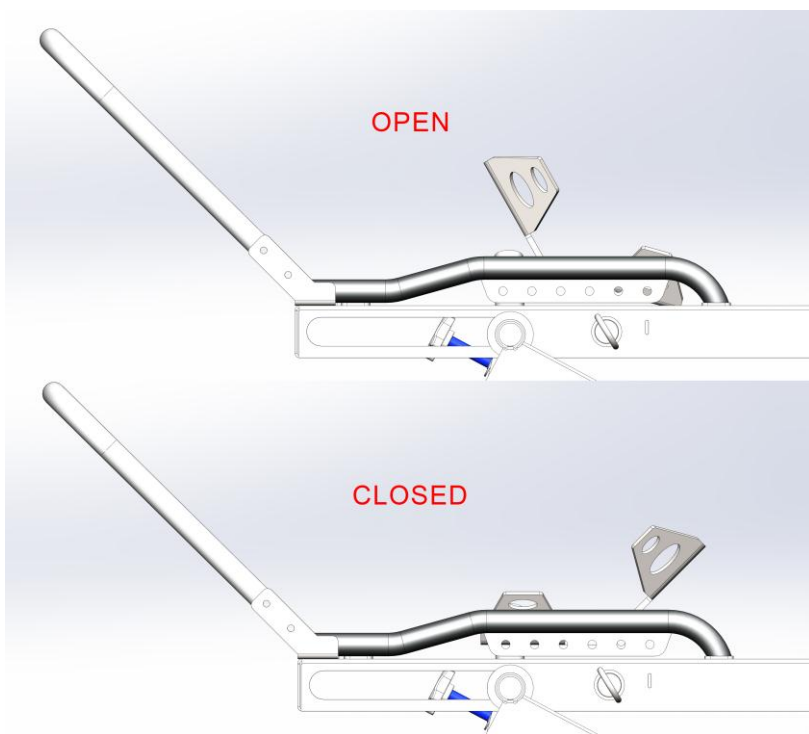

Please contact us directly at 714-630-7144 or info@KendonUSA.com if you have any questions about ramp use or attachment.

Kendon Stand-Up™ Lift Owner's Manual

Congratulations on your purchase of a Kendon Stand-Up™ Motorcycle Lift. Safety is our number one concern. Before using this product, please take the time to completely read this motorcycle lift Owner's Manual and familiarize yourself thoroughly with the parts on your new Kendon Lift. In addition to this manual, be sure to read and follow the separate usage instructions for your specific model Stand-Up™ Motorcycle Lift (if applicable).

Read and understand all warnings and warning labels on the lift before use. Do not remove any warning labels or warning tags.

Using any lift, proper loading, unloading and securing of the vehicle is serious business with inherent risks. Serious injury, death and/or property damage can result to operator and/or others through improper use of this product.

If you have any questions or need additional help or instructions, please contact us directly at 714-630-7144 or info@KendonUSA.com.

Visit us at **www.KendonUSA.com** for product updates, new products, and support.

WARNING

Risk of injury and/or property damage: There is an inherent risk in the loading and unloading process. Failure to load your vehicle properly could result in serious injury and/or property damage.

Most Common Hazards

- Failure to read instructions.
- Loss of balance while loading.
- Slippery surfaces (wet, snow and/or icy surfaces are dangerous to load and unload on).
- Ramp not properly attached.
- Loading a vehicle when under the influence; load and unload with the same mental capacity needed for riding or driving.
- Rider Error.

This is not a complete list of all risks. Physical strength, weight of vehicle and riding skills all vary widely. Only you can determine your comfort level through safe practice. Kendon wants you safe!

Loading and Unloading Process

Loading and unloading a motorcycle onto a lift or any other vehicle, such as a trailer or a pick-up truck requires certain skills and techniques. Kendon recommends using at least one spotter while practicing the loading and unloading technique with your bike with your abilities. Most incidents occur from first time users with no experience in loading and unloading a motorcycle. Practicing the process with a spotter is highly recommended. Kendon does not recommend riding your motorcycle onto the motorcycle lift.

WARNING

LOAD, UNLOAD AND USE AT YOUR OWN RISK. KENDON INDUSTRIES, LLC IS NOT RESPONSIBLE FOR ANY INJURY, LIABILITY, PROPERTY DAMAGE AND/OR CONSEQUENTIAL DAMAGE(S) CAUSED BY LOADING AND UNLOADING A VEHICLE.

If you have any questions or need additional help or instructions, please contact us directly at 714-630-7144 or info@KendonUSA.com.

Expanded Drawing & Numbered Parts List

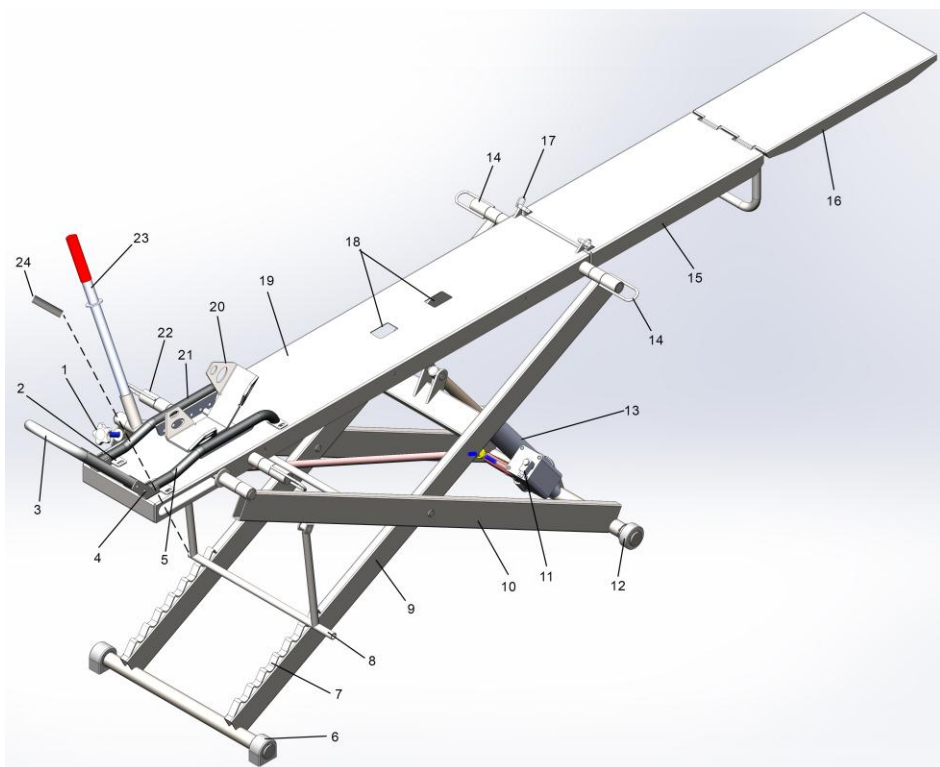

1	Lift Release Knob
2	Front Wheel Loop Brackets (2)
3	Front Wheel Loop
4	Front Wheel Loop Detent Ring Pins 5/16" (6)
5	Front Wheel Left Guide Rail
6	Lift Front Foot (2)
7	Height Positioner
8	Height and Safety Lock Bar
9	Inside Scissor
10	Outside Scissor
11	Air Hose with Air Attachment
12	Rear Caster Wheel (2)
13	Air-Over-Hydraulic Bottle Jack
14	Rear Tie-Down Hook (2)
15	Rear Rail Section
16	Loading Ramp
17	Rear Rail Detent Ring Pins 1/2" (2)
18	Fluid Drain Holes

19	Front Rail Section
20	Wheel Chock
21	Front Wheel Right Guide Rail
22	Front Tie-Down Hook (2)
23	Jack Handle
24	Safety Lock Bar Extender

Thoroughly read and understand these instructions and the Owner's Manual for your specific model Stand-Up™ Motorcycle Lift, where applicable.

Un-Crating and Assembly Instructions

To ensure your satisfaction with our motorcycle lift, the removal of the lift from the crate and the installation of the front wheel loop and rear rail must be performed according with the detailed instructions noted below. The assembly and installation requires the basic knowledge and use of hand tools listed in the "Recommended Tools" section. If you don't feel you have the capacity to perform this type of installation, or if you have any questions, please contact us via phone at 714-630-7144, 800-847-8618 or via email at info@kendonusa.com.

Recommended Tools:

1. Pry Bar or Hammer
2. 9/16" Socket and Wrench OR 9/16" Combination Wrench
3. Box cutter or similar

Removal from Crate:

1. Carefully cut the plastic retaining straps secured around the crate on each side of the lift crate using a box cutter or similar tool.
2. Pry open the top cover of crate using a pry bar or hammer. Be sure to use caution when lifting the top cover off as nails will be exposed. Kendon recommends removing the nails prior to lifting off the top lid.
3. Remove all packaged small loose parts from the crate.
4. Knock apart all four wood sides of the crate to allow for lift removal.
5. Remove any bubble wrap from lift and loose parts.
6. Attach the rear rail to the front rail using the supplied ½" detent ring pins and fold over the front rail, then secure using the rubber latch on the right side of the lift.
7. Carefully tilt the lift up by lifting the front part of the lift (opposite of caster wheels) slightly so that the lift can roll on its casters.
8. With the help of a second person, while lifting the front of the lift, lift the back of the lift from the crate base onto a flat surface, such as a garage floor.

9. Roll the lift on its casters to a flat surface area to complete the installation.

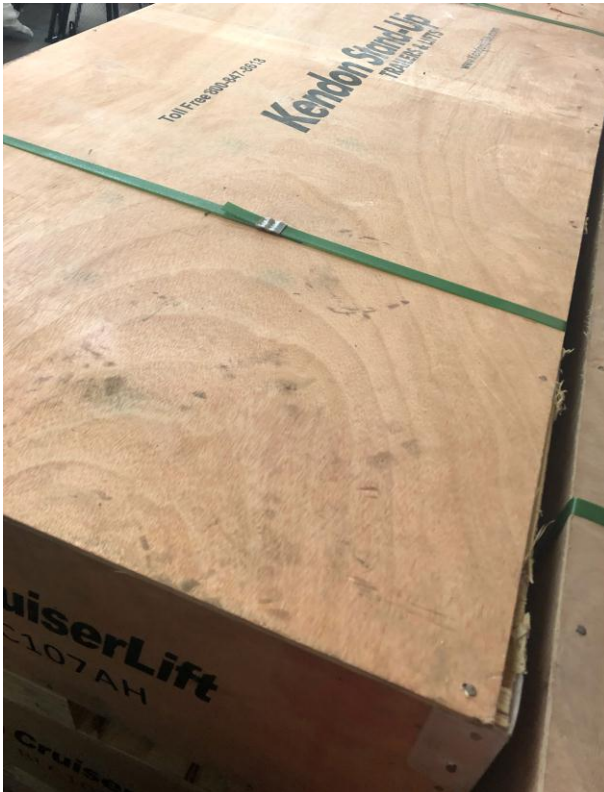

Front Loop Installation:

1. Attach the two front wheel loop brackets to the front most part of the lift front rail using the supplied hex bolts and washers and a 9/16" wrench.
2. Then insert the right and left guide rails and secure using the supplied hex bolts and lock nuts.

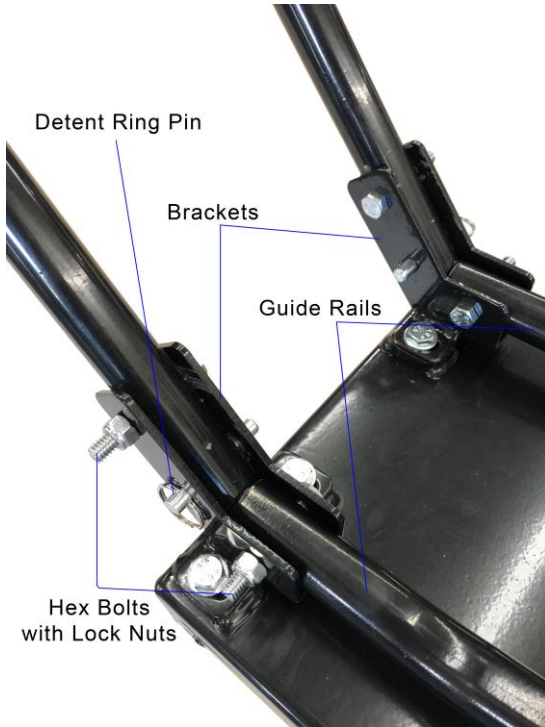

3. Attach the back of each left and right guide rail using the supplied hex bolts and washers using a 9/16" wrench.

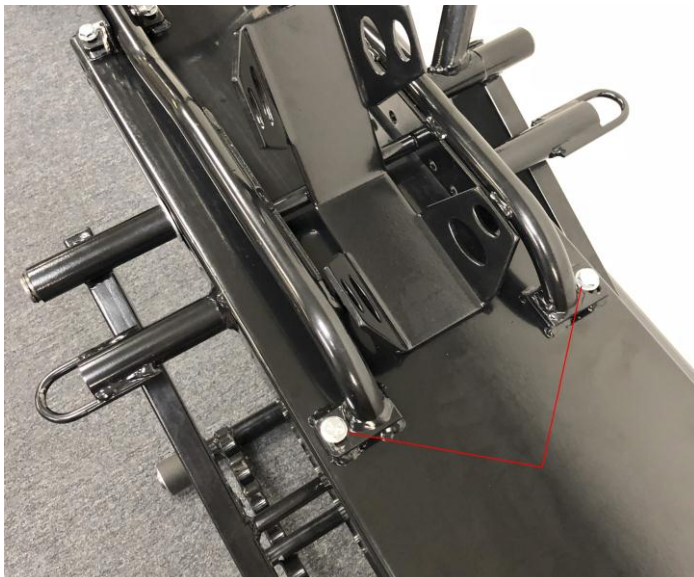

4. Attach the wheel chock as shown above using the supplied 7" ring pin.
Note: Depending on the size of your front wheel the wheel chock may have to be adjusted. Be sure to check fender and fairing clearance prior to using wheel chock.

5. Secure the front wheel loop using the supplied hex nuts with lock nuts and 5/16" detent ring pins.



Congratulations! The lift assembly is now complete and ready for use.

About your Lift's Air-Over-Hydraulic System

Kendon Stand-Up™ Motorcycle Lifts are equipped with an Air-Over-Hydraulic bottle jack. This means that the lift can be actuated using an air compressor or manually using the supplied hand pump. To use your lift with an air

compressor, simply insert the air fitting on the integrated hose into your compressor. Please note that there are many air fittings used by our customers. You may be required to switch the fitting on your lift and/or compressor to accommodate the appropriate fitting. Due to the lift's 1000 lbs. lifting capacity, there are certain restrictions on the size of compressor that can be used to actuate the lift. Kendon's minimum recommended air compressor size is 150 PSI with a 6-gallon tank or larger. For optimal use, we recommend 150 PSI to 175 PSI compressor with an 8-gallon or larger tank. Please be sure to let the compressor run and completely fill the tank prior to using with the lift.

Operating Instructions

Before Use

- Inspect lift before each use. Do not use if bent, broken or cracked components are noted.
- Check to ensure pump operates smoothly before putting into service. Lubricate as instructed in the Maintenance Section.
- It is good measure to check the hydraulic system of the lift prior to use; especially if stored for an extended period of time. With ram fully retracted, locate and remove the oil filler plug on the front of the hydraulic cylinder. Insert the jack handle into the sleeve and pump lift until it locks into the first safety height lock. This will help release any pressurized air which may be trapped within the reservoir. Ensure the oil level is just below the oil filler plug hole. Reinstall the oil filler plug.

Loading

WARNING

Because of the many designs and weight of motorcycles, it is the owner's responsibility to determine if assistance is needed to load or unload your particular equipment. However, we believe that in the interest of safety, help of at least one spotter should be acquired prior to any attempt to load or unload motorcycles.

Before loading, ensure that the lift is on a clean and flat level surface. Be sure the lift front feet are firmly planted on the ground and rotated with the flat surface facing the ground.

1. Lay your Kendon Stand Up™ Lift lying horizontally on the ground. Ensure that it is fully retracted (e.g., ensure that the piston on the jack itself is fully retracted – as with any air-over-hydraulic jack, it can appear to be fully retracted, but can have a small amount of travel remaining). To do this, simply push down on the Rail to confirm that the lift is fully lowered. Unhook the rubber latch and fold out the rear section of the rail assembly.
2. Insert the loading ramp into the rear section of lift as shown below.

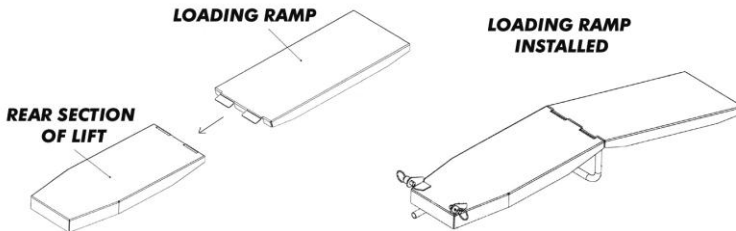

3. The ramp is now securely attached and extends out from the back of the folding rear section of the lift.
4. Ensure the wheel chock on the rail is in the open position. The wheel chock is in the open position when the wheel chock is rotated towards the rear of the rail and the wheel chock channel will receive the front tire of your motorcycle when it is loaded onto the rail.

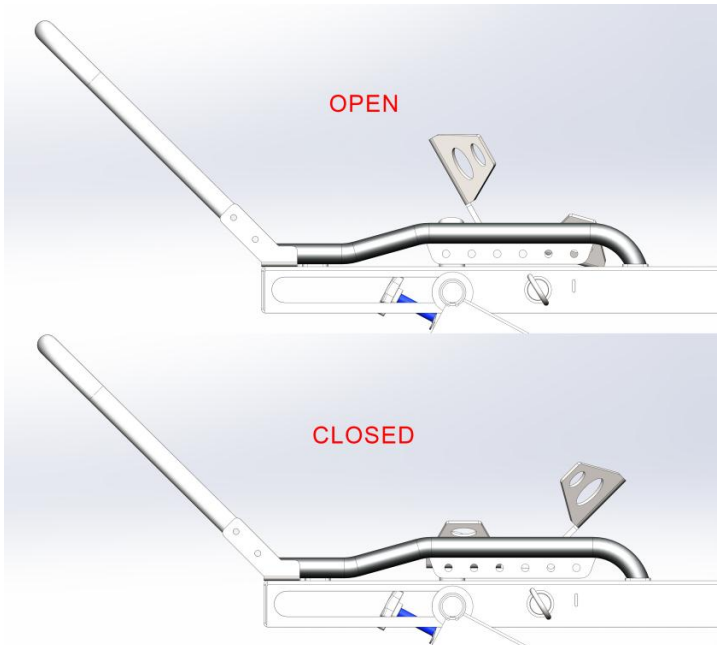

WARNING

You must check to ensure that the wheel chock will not contact fender, fairing or other parts of your motorcycle **BEFORE** loading. The wheel chock is designed to accommodate a variety of motorcycles, but Kendon is not responsible to ensure that the wheel chock will fit any particular motorcycle. Measure clearance **BEFORE** use.

5. The motorcycle **must** be loaded on the center of the loading ramp. If the motorcycle is off-center, the ramp may be damaged and the motorcycle may fall off the ramp resulting in serious injury or death.
6. Standing beside your motorcycle, push it up the ramp and all the way up onto the Rail. As the front wheel on your motorcycle passes over the open wheel chock, the wheel chock will rotate forward. The front tire of your motorcycle will now be pushing down on the wheel chock, which will rotate into the closed position. This causes the wheel chock to clasp the front wheel of your motorcycle in place, holding the motorcycle upright.

NOTE: This is **NOT** a substitute for securely tying your motorcycle onto the lift.

7. Secure your motorcycle using LOCKING RATCHET-STYLE TIE-DOWN STRAPS. Please ensure that the tie-down straps are locked in place and

hold the motorcycle safely on the Lift. Failure to correctly and safely tie the motorcycle in place will void your lift warranty and may cause injury or death in the event that the motorcycle was to become dislodged from the lift.

Correct Tie-Down Procedure

In order to safely use the Kendon Motorcycle Lift, locking type ratchet tie downs must be used on the front and rear of the motorcycle. This will ensure that the bike is safely secured to the lift.

1. From handlebars or fork area, using Kendon (or similar) locking ratchet tie-downs, connect the tie-down straps to the forward outrigger tie-down rings/hooks. Ratchet the tie-down straps to compress the motorcycle suspension until motorcycle is secure. This will typically require that you compress the front suspension on your motorcycle to approximately 75% of its full travel (Note: Do not over tighten the tie downs as to not blow out fork seals and cause damage to bike).
2. From a rear motorcycle frame attachment point (i.e. frame, swing arm, passenger foot pegs) using Kendon locking ratchet tie-downs (or similar), secure the motorcycle to rear outrigger tie-down rings/hooks, and ratchet until motorcycle is secure. Again, this will require you to compress the rear suspension on your motorcycle until there is no possibility that the motorcycle could become dislodged.

Raising and Lowering your Kendon Lift

WARNING

DO NOT insert any body parts (e.g., fingers, arms, etc.) within the interior frame of the lift while raising or lowering your Kendon Motorcycle Lift.

Raising the Lift

1. Your motorcycle is now on the Lift platform and the wheel chock is in the closed position, holding the motorcycle upright. Now you can safely raise the Lift using either a compressor or the hand pump lever.
2. Close the Release Valve by turning the Release Valve Assembly to the right.



3. Hydraulic Operation - With pump handle securely inserted into the pump handle assembly, actuate the internal hydraulic cylinder by pumping the pump handle back and forth. For Air-Over-Hydraulic operation, simply connect your compressor to the lift and turn on the air. If the lift does not rise, repeat step 2 above, by tightly closing the release valve. Do **NOT** over-tighten the release valve.
4. As the lift is raised, the locking height/safety bar will lock into place. When the lift is raised to the desired height stop actuating the lift and slowly open the release valve by turning it to the left one quarter turn and allowing the jack to retract (lower) the lift and drop onto the height lock.

NOTE: In order to lock the lift in its highest attainable height of 32" you will have to manually position the height lock into the final safety lock. Please use the supplied Safety Lock Bar Extender to safely position the height lock into place.

5. If you inadvertently miss the desired height position, you can actuate the lift using the lift pump handle and then following the lowering procedure until you lock the lift in the desired height lock.

6. The lift is now locked in place and secure so that you can work on your motorcycle.

WARNING

Maximum Height – It is possible to raise your Kendon Stand Up™ Bike Lift above the maximum operating height. This is required so that the locking safety bar/height adjuster can be freed from the height lock allowing the lift to be lowered back down to the ground. **DO NOT** raise the lift any higher than absolutely necessary to disengage the safety bar.

Lowering the Lift and Unloading

1. Slide out the supplied Safety Lock Bar Extender from the safety lock/height positioner (as shown below) extending it safely passed the Outer Scissor assembly and Lift Foot making sure not to disconnect it from the lift.



2. Raise the lift slightly (using the hand pump or air compressor) to release the safety bar from its locked position.
3. Using the outer part of the supplied Safety Lock Bar Extender rotate the safety bar/height lock bar away from the height positioners.

WARNING

The use of the Safety Lock Bar Extender is **required** in order to safely lower the lift. Be sure to keep fingers, hands, and other limbs as far away from the lift as possible while lowering to prevent any crushing type injuries. Failure to follow these safety precautions can result in serious injury or death.

4. The Kendon lift is lowered by releasing the Air-Over-Hydraulic cylinder. **DO NOT OVER-TIGHTEN** or **OVER-LOOSEN THE RELEASE VALVE** on the internal Air-Over-Hydraulic cylinder. One-quarter turn is generally sufficient to open or seal the cylinder. The release valve knob is the assembly that extends from the bottom of the Air-Over-Hydraulic cylinder housing to the front of the lift, located beside the pump handle. This release valve should be turned only in small increments. You can control the lowering speed of your Kendon lift by slightly opening and closing the release valve. If you open it up too much, especially with a heavy motorcycle secured to the lift, the lift will descend quickly. By “togging” the release valve open and closed during descent, you can safely control the rate of descent as your Kendon lift is lowered to remove the motorcycle from the lift.
5. In the event that you wish to slow or stop the descent of the lift, simply turn the release valve to the right and the jack will be sealed and the lift will stop its descent.
6. Insert the ramp into the rear folding section of the lift.
7. When you release the Tie-Down straps the motorcycle will jump or shift somewhat. It is best to have an assistant holding the handlebars of the motorcycle to keep it stable at the moment that the Tie-Down straps are released. **USE CAUTION** when releasing tie-down straps.
8. After releasing the tie-down straps, pull the motorcycle out of the wheel chock, and roll the motorcycle off of the Lift. **NOTE** – removing the front wheel of the motorcycle from the wheel chock is very easy. However, you may feel more comfortable with this procedure after you have practiced a few times. We **STRONGLY RECOMMEND** that you have an assistant to help you during the first few times you take the motorcycle out of the wheel chock.

Pulling the Motorcycle Wheel out of the Wheel Chock

1. With the tie-down straps removed, push down on the handlebars of your motorcycle, slightly compressing the front suspension of the motorcycle.

2. Pull up and back on the motorcycle handlebars.
3. Keeping your hands on the handlebar brake, squeeze the motorcycle brake lever as the wheel chock rotates backwards. This freezes the front wheel of the motorcycle at the “balance point” between the closed position and the open position as the wheel chock is rotating backwards.
4. Pull the motorcycle backwards again, releasing the motorcycle handlebar brake lever. This will cause the wheel chock to rotate into the full open position and the front wheel of the motorcycle to fall onto the main lift rail assembly.
5. Now you can roll the motorcycle off of the lift.

Standing your Kendon Stand Up™ Lift for Storage

1. Fully lower the lift as described in the Lowering the Lift section.
2. Remove the ramp and store it separately. The ramp can also be stored on the lift by placing the ramp between the front rail and rear folding rail then securing with the rubber latch.



3. Remove all cords, hoses, tie-down straps etc.
4. Remove the pump handle and store it separately.
5. With the lift now in a horizontal position, fold the folding rear section of lift closed and attach the rubber latch to the main frame of the lift.
6. In the horizontal position, the lift stands on three feet. Two have rollers; one does not. The lift is designed to stand up on the roller feet at the bottom of the scissor assembly.
7. Rotate the lift into a standing position by lifting the non-roller feet (do NOT use the tie-down rings for lifting). Tilt the lift onto the rollers and continue standing the lift upright until the support at the bottom of the folded rear section of the lift touches the floor and lift is upright standing.
8. To move the lift, tilt it slightly and roll on the rollers to the storage location, then tilt the lift to a vertical, upright position.

WARNING

IMPORTANT: The lift is designed to stand upright. However, it is heavy and may be knocked over. It is **IMPERATIVE** to secure the upright lift to the wall using a **HEAVY DUTY** cable. Failure to obey this warning will void the warranty on your Kendon Stand-Up™ Motorcycle Lift and may cause serious injury or death.

Putting the Kendon Lift Back Down for Use

When it's time to use your Kendon Stand Up™ bike lift again, it's important to be careful lowering it from the standing position.

1. The Lift weighs over 150 pounds. If you cannot comfortably lift 100 to 150 pounds, do NOT attempt to raise or lower the lift to or from the storage position without assistance. Failure to obey this warning will void the warranty on your Kendon Lift and may cause serious injury or death.
2. With assistance, tilt the lift down from standing position by securely holding the non-roller feet. Rotate the lift down until all four feet are securely on the floor. Make sure the lift is level on a flat concrete or asphalt surface.

3. Follow the Loading and Raising instructions described earlier in this manual.

Maintenance

Use only good grade hydraulic jack oil. Avoid mixing different types of fluid and NEVER use brake fluid, transmission fluid or motor oil. Improper fluid can cause premature failure of the jack and the potential for sudden and immediate loss of load. When used daily with an air compressor, pour a teaspoon of proper lubricant into the air inlet of the lift control valve. Connect valve to air supply and squeeze valve lever to operate. This will evenly distribute lubricant and properly prepare the hydraulic power unit for use. Periodically check for leaks at air connections. Use thread compound to repair. Avoid the use of thread tape when possible.

Cylinder Repair

In case cylinder malfunctions, it may be due to air bubbles in the hydraulic cylinder. In such a case follow this procedure:

With ram fully retracted, locate and remove the oil filler plug. Insert handle into the handle sleeve, then pump until lift reaches the first safety lock. This will help release any pressurized air which may be trapped within the reservoir. Ensure the oil level is just below the oil filler plug hole. Reinstall the oil filler plug and lower the lift.

Adding Oil

With ram fully lowered and pump piston fully depressed, set jack in its upright, level position. Carefully remove from lift. Remove oil filler plug. Fill until oil is level with the filler plug hole. Reinstall oil filler plug.

Changing Oil

For best performance and longest life, replace the complete fluid supply at least once per year. Remove the cylinder from the lift and follow this procedure:

1. With ram fully lowered and pump piston fully depressed, remove the oil filler plug.
2. Lay the jack on its side and drain the fluid into a suitable container.
3. Set jack in its level upright position.

4. Fill with good quality jack oil. We recommend Mobil DTE 13 or equivalent.

Lubrication

- A coating of light lubricating oil to pivot points and hinges will help to prevent rust and assure that pump assemblies move freely.
- Periodically check the pump piston and ram for signs of rust or corrosion. Clean as needed and wipe with an oily cloth.

Troubleshooting

SYMPTOM	POSSIBLE CAUSES	CORRECTIVE ACTION
Jack will not lift load	Release valve not tightly closed Overload condition Hydraulic unit malfunction	Ensure release valve tightly closed Remedy overload condition Ensure adequate air supply
Jack will lift, but not maintain pressure	Release valve not tightly closed Overload condition Hydraulic unit malfunction	Ensure release valve tightly closed Remedy overload condition Contact Kendon for Service
Jack will not lower after unloading	Reservoir overfilled Linkages binding	Drain fluid to proper level Clean and lubricate moving parts
Poor lift performance	Fluid level low Air trapped in system	Ensure proper fluid level With ram fully retracted, remove oil filler plug to let pressurized air escape, then reinstall oil filler plug
Will not lift to full extension	Fluid level low	Ensure proper fluid level

Safety Precautions

- NEVER ride bike up onto lift.
- DO NOT raise Lift with bike untied.
- Do not hold onto lift while raising and lowering.
- Do not raise or lower lift using your own strength.
- DO NOT put any body parts within the interior frame of the lift while raising or lowering.

- Always use the front swing arm height support.
- Never just use the air jack alone to maintain a raised level height.
- Keep all latches attached in all latching sections.

Disclaimers:

Krylon, Fusion, Rust-Oleum, Scotch-Brite, Teflon, Lucas Oil, Red N' Tacky, Mobil and WD-40 are the registered names and/or trademarks of their respective trademark holders. Kendon Industries, LLC is not in any way associated with or endorsed by these brands. Product names, logos, brands, and their trademarks featured or referred to within this Owner's Manual are the property of their respective trademark holders. These trademark holders are not affiliated with Kendon Industries, LLC, our products, or our web site. They do not sponsor or endorse our materials.

The Kendon name and all trademarks and logos displayed in this manual are owned or used under license by Kendon. These trademarks include, but are not limited to, product brand names, product model names, slogans, and logos and emblems (e.g., Kendon®, Stand-Up™, MotoLift™). The unauthorized use of any trademark displayed in this manual is strictly prohibited.

Copyright © Kendon Industries, LLC. All rights reserved. This manual, including all content and materials, is protected by worldwide copyright laws and treaty provisions whether or not a copyright notice is present on the materials. All text, images, graphics, and other materials in this manual are subject to the copyrights and other intellectual property rights of Kendon and its licensors. You agree to comply with all copyright laws worldwide in your use of this manual and to prevent any unauthorized copying of the materials. Except as expressly provided herein, Kendon does not grant any expressed or implied rights to you under any patents, trademarks or copyrights.

This manual and all the information it contains is provided for information purposes only on an "as is" basis and could include technical, typographical or other errors. In certain areas, the information provided may represent an opinion or judgment. Kendon, information providers, and their agents make no warranties, representations, or guarantees of any kind, express or implied, including but not limited to, accuracy, currency, or completeness of this manual, the information, materials, content, availability, and products. To the extent permitted by applicable law, Kendon disclaims all warranties, expressed or implied, including but not limited to, implied warranties of merchantability and fitness for a particular purpose. Kendon is not responsible for the content of any web site, document, or other source that is linked to or referenced to this manual and is not directly or indirectly implying any approval, endorsement or affiliation with any linked source.

Kendon reserves the right to change, modify, suspend, discontinue or permanently cancel this owner's manual or portions thereof without any prior notice to you, including but not limited to product specifications or instructions, at any time and from time to time without notice and without incurring any obligations.

Lift Limited Warranty

The lift assembly on all Kendon lifts is warranted against defects in manufacture or design for a period of one (1) year from date of original purchase. This is a LIMITED WARRANTY and this written warranty is offered in lieu of all other warranties express or implied, except as may be required by law. In order to be eligible for warranty service, the "Product Warranty" Registration Card received with the lift must have been completed and submitted to Kendon by the customer. ***If you did not receive a Product Warranty card, please contact us at 800-847-8618, 714-630-7144, info@kendonusa.com or visit www.KendonUSA.com/registration.*** To request warranty repairs, the lift must be returned to Kendon, freight prepaid, with an RGA (Return Goods Authorization) number and copy of the original purchase receipt. Should the lift need to be returned to Kendon for repair, the Customer is responsible for all shipping costs to and from Kendon Industries LLC, 1672 Sierra Madre Circle, Placentia, California 92870. This warranty is not transferable and may be claimed only by the original purchaser of the lift. This limited warranty becomes null and void in the event that **any** customer modifications are made to the lift. This limited warranty provides repair or replacement at Kendon's discretion. This Limited Warranty covers no consequential damages, or normal wear and tear. In the event of any dispute regarding this Limited Warranty between Kendon and the customer or any other party, each party shall bear their own legal costs and fees. Please refer to the Product Warranty Card for further details.

Inquiries regarding this warranty should be sent to or emailed to the address(es) below:

Kendon Industries, LLC

Attn: Warranty Department

1672 Sierra Madre Circle

Placentia, CA 92870

Toll-Free: 800-847-8618

Tel: 714-630-7144

Fax: 714-630-7132

E-Mail: warranty@KendonUSA.com

Thank you again for purchasing our Kendon Product. If you have any questions on the proper use of this lift please contact Kendon directly at 714-630-7144 or info@KendonUSA.com.

Kendon Industries, LLC

1672 Sierra Madre Circle
Placentia, CA 92870
714-630-7144 Telephone
714-630-7132 Facsimile

info@KendonUSA.com
www.KendonUSA.com

facebook.com/kendonusa
instagram.com/kendonindustries

NOTES

NOTES

⚠ WARNING

- WARNING:** Serious injury, death and/or property damage could result through improper use of this product, including crushing or severing type injuries.
- WARNING:** Thoroughly read and understand all instructions and owner's manual(s) before using the lift.
- WARNING:** For Adult Use Only. Keep children away from lift at all times.
- WARNING:** You must check to ensure that the front wheel chock on the lift will not contact the bottom rear of your front fender, fairing or other parts of your motorcycle **BEFORE** loading.
- WARNING:** Lift should only be loaded and unloaded on a stable flat surface with the lift front feet properly rotated with the flat surface facing the ground.
- WARNING:** Properly attach the loading ramp as per this manual's instructions.
- WARNING:** Obey lift capacity limits.
- WARNING:** There is an inherent risk in the loading and unloading process. Failure to load your vehicle properly could result in serious injury and or property damage. Load and unload at your own risk.

Lift owner is responsible for complying with all the recommended procedures in this instruction manual. Use at your own risk. Kendon is not responsible for injury, liability, property damage and/or any consequential damage(s) caused by the misuse of this product.

This page intentionally left blank

Stand-Up™ Lift Parts & Accessories

COMING SOON

Visit us at www.KendonUSA.com for product updates, new products, and support.

KendonStand-Up
TRAILERS & LIFTS

NO PART OF THESE INSTRUCTIONS MAY BE COPIED AND/OR REPRODUCED WITHOUT THE WRITTEN PERMISSION OF KENDON INDUSTRIES, LLC. ALL PART NUMBERS, DIMENSIONS AND SPECIFICATIONS IN THESE INSTRUCTIONS ARE SUBJECT TO CHANGE WITHOUT PRIOR NOTICE.
