

Rollergard Assembly Instructions

Illustration #1

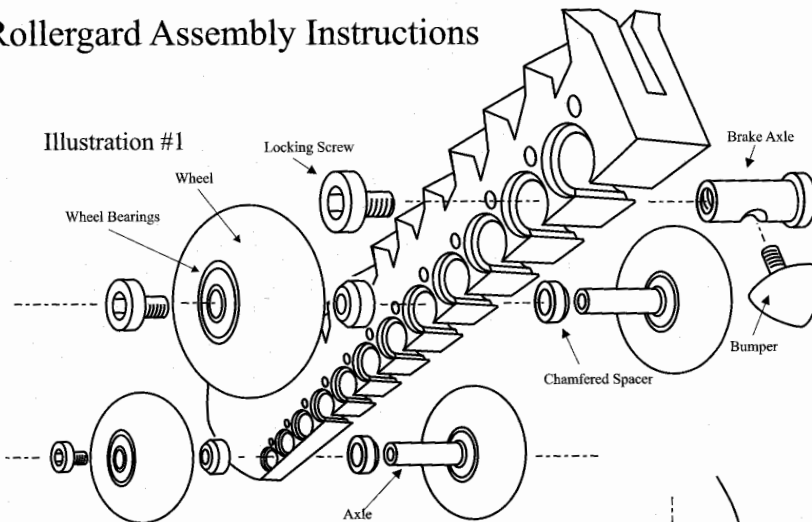
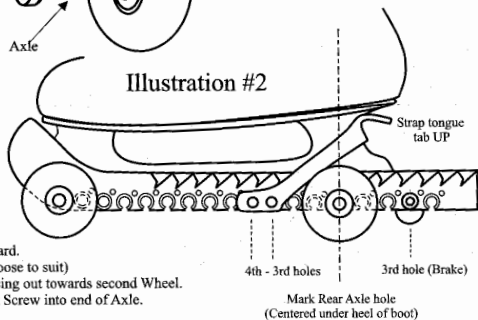
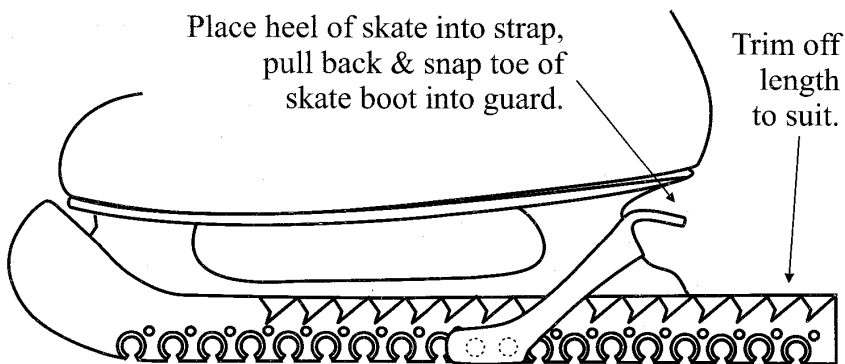

Illustration #2



- Step One -
 - Assemble Bearings into each Wheel. 8 Wheels & 16 Bearings.
 - Front Axle & Wheel Assembly to Guard.
 - Slide one Wheel onto an Axle.
 - Slide Spacer onto Axle with chamfered (beveled) edge facing towards Wheel.
- Then -
 - Slide Axle thru first closed hole of the skate Guard. (Up to size 3 use first hole, all others choose to suit)
 - Slide second Spacer onto Axle with chamfer facing out towards second Wheel.
 - Slide on second Wheel and start threading Lock Screw into end of Axle.
 - Use the two tools provided to tighten assembly.
- Step Two -
 - Slide your hockey skate tightly into the nose of the skate Guard.
 - Mark the hole in the Guard directly under the back of the heel of the hockey skate boot. (as shown in illustration #2).
 - Remove the hockey skate from the Guard.
 - Slide the heel locking Strap onto the skate Guard (with the tongue up)
 - Lock it into the 3rd and 4th hole forward from the marked hole (see illustration #2).
- Step Three - (Brake Assembly)
 - Slide Brake Axle into 3rd hole back from rear Wheel Assembly axle hole (see illustration #2).
 - Rotate Brake Axle so that the Bumper retaining hole is centered in the slot.
 - Start threading the Locking Screw into the end of the Brake Axle.
 - Assemble the brake Bumper screw into the retainer hole of the Brake Axle and tighten.
 - Then, take the two tools provided and tighten into axle end.
 - Assemble rear axle
- Step Four -
 - Assemble the other Rollergard using Steps One, Two and Three.
 - Trim rear length of the Rollergards to suit.

Rollergard.com
info@rollergard.com



Note: Supergard not intended for wheel use.