

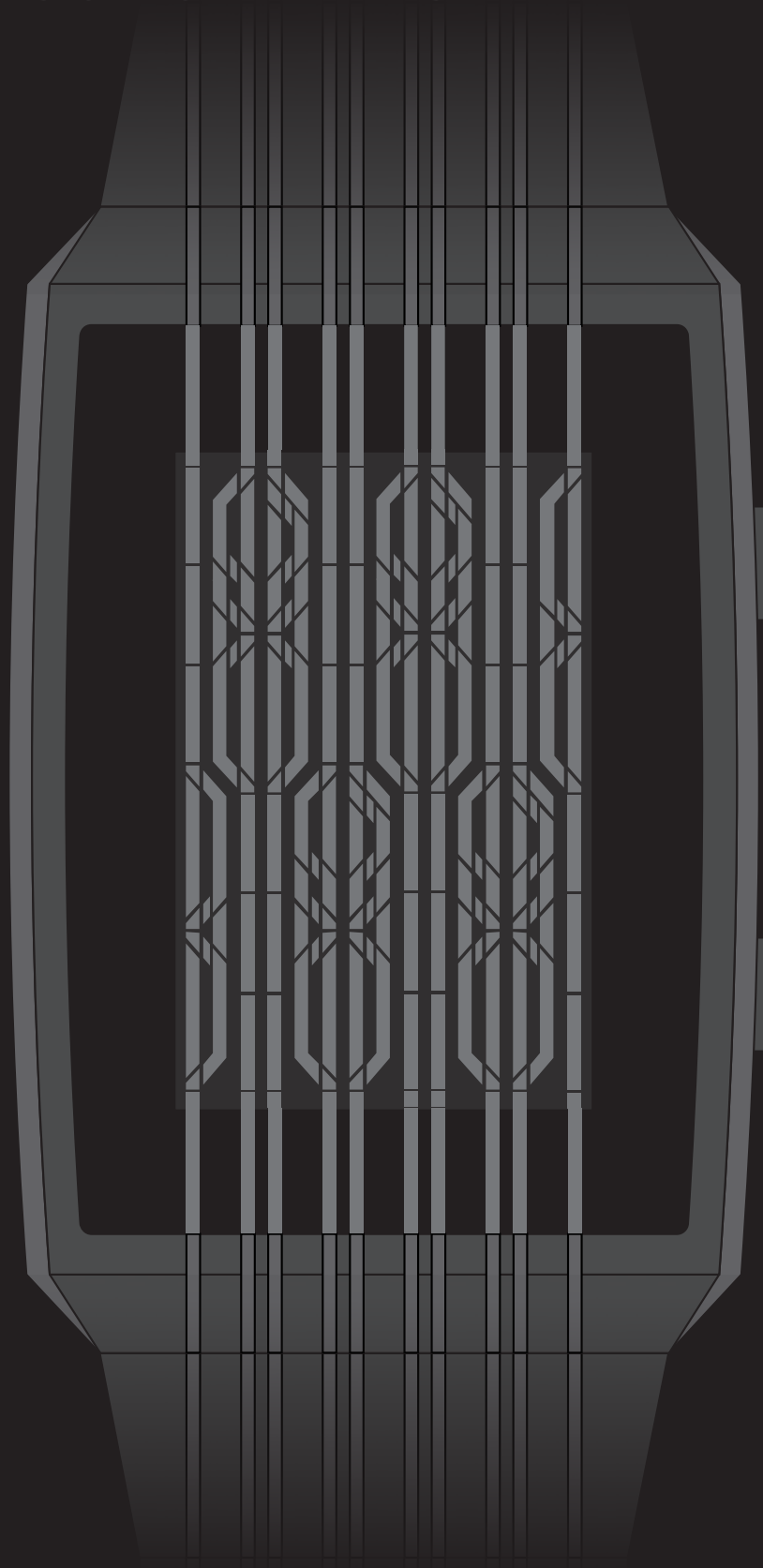

Change the way you think about time

ONLINE

INSTRUCTION MANUAL



..... Button A

..... Button B

1. How to read the time

- This watch uses an LCD “always on” display to show the time.
- It uses an accelerometer which changes the display from “cryptic mode” (see example 1) to “easy mode” (see example 2) when you turn the watch towards you to view the time.

Example 1:
12:47
cryptic mode

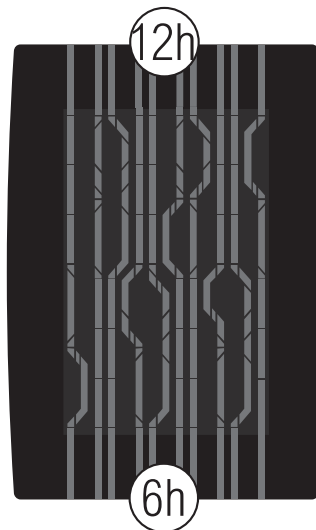
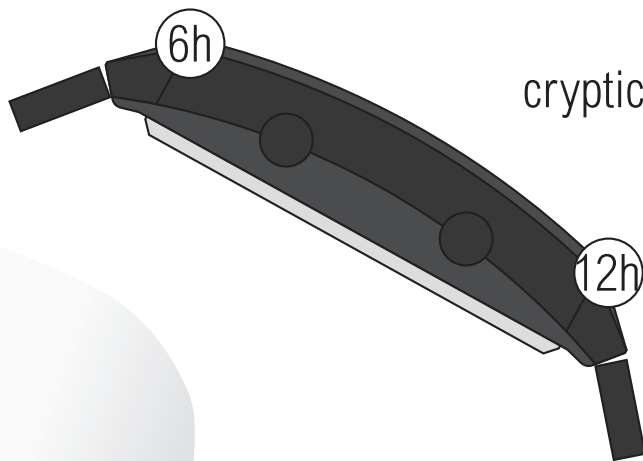

Time checking position

Example 2:
12:47
easy display mode

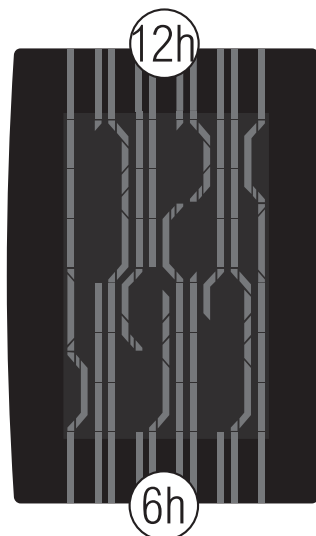
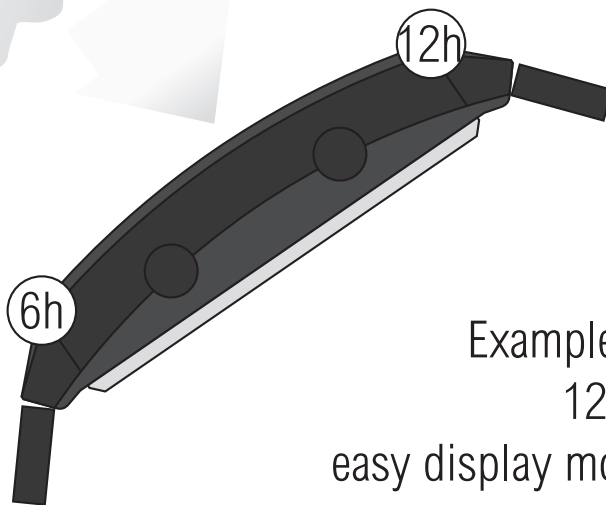

- The time is displayed digitally, hours in the upper half of the screen, minutes in the lower half of the screen.
The digits for “cryptic time” and “easy time” are shown below.

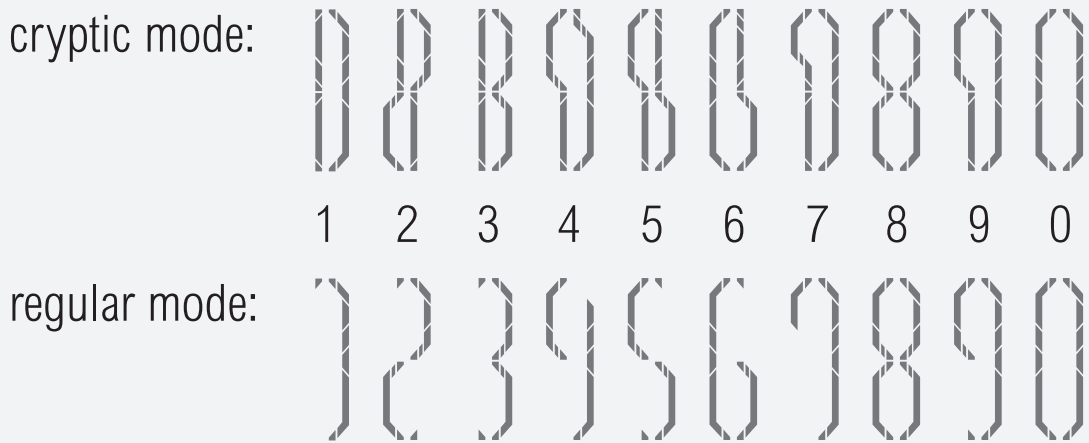
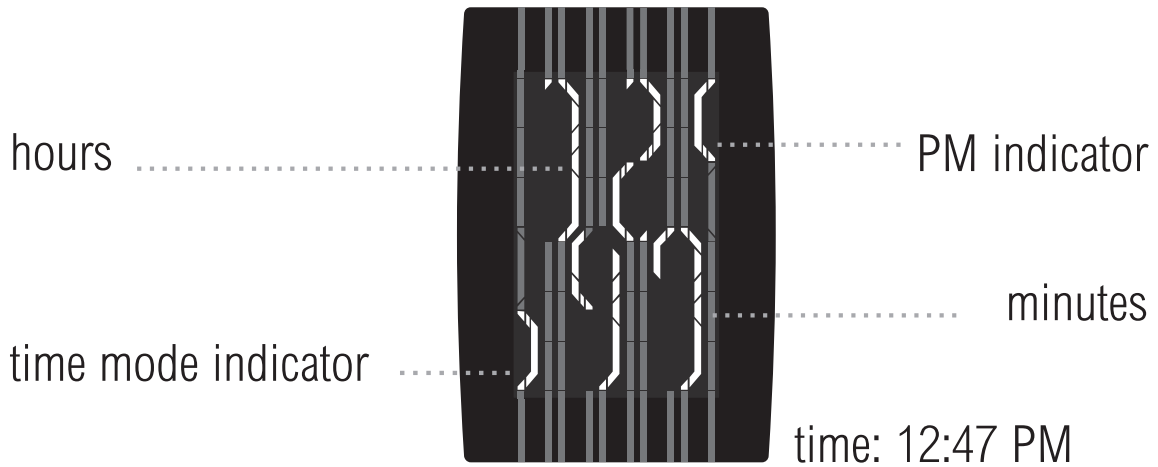

- Time examples:

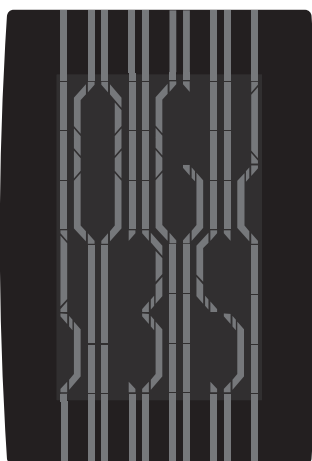

time: 06:35 AM

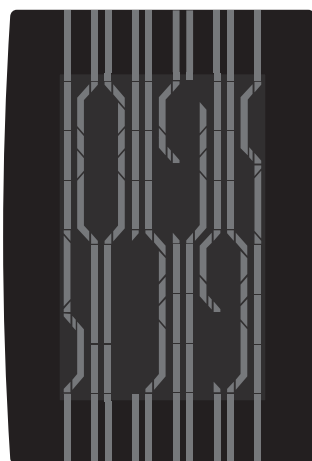

time: 04:19 PM

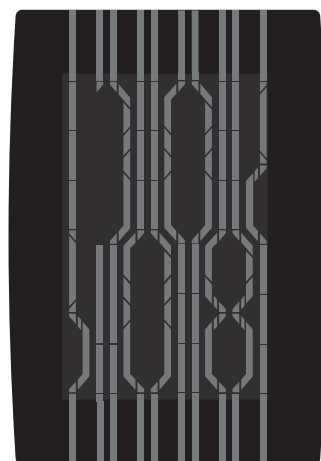

time: 10:08 AM

2. Operating the basic functions

I. Turning on the backlight

- You can illuminate the display for a short time with the EL backlight by pressing button A.
- This function works best at night time.

II. How to read the date

- Press button B to display the date. The date icon indicates that you are in date mode.
- The date is displayed in the same way as the time, with the month in the upper half of the screen and the date in the lower half of the screen.

Example 1:

May 23rd

month
date indicator
date
button B

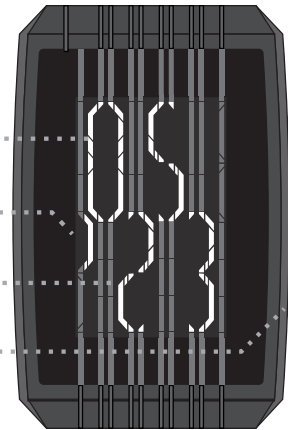

Example 2:
february 9th

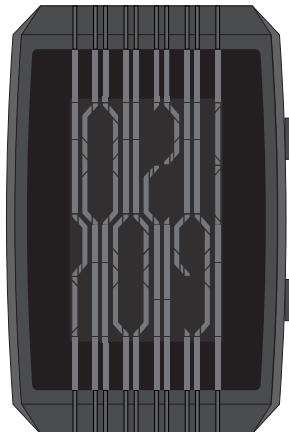

Example 3:
june 1st

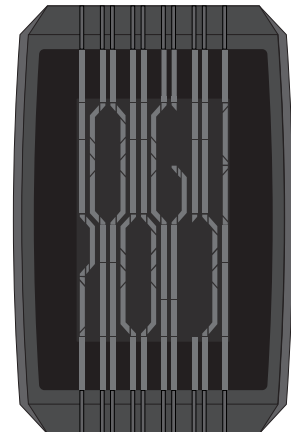

- The display will change back to time mode after a short time.

III. How to check the alarm time

- Press button B twice to display the alarm time.

The alarm mode icon indicates that you are in alarm mode.
The alarm on/off icon indicates that the alarm is either on or off.

The display will change back to time mode after a short time.

Example 1:

07:30 AM alarm off

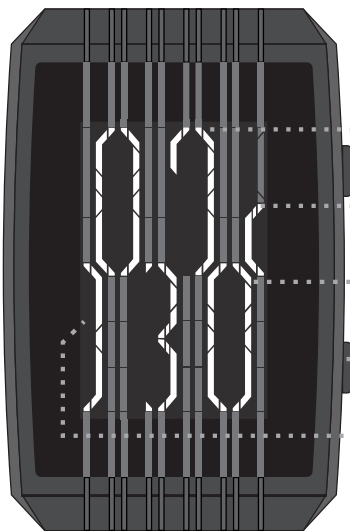

hours

AM indicator

minutes

button B

alarm indicator
(alarm off)

alarm indicator
(alarm on)

Example 2:

07:30 AM alarm on

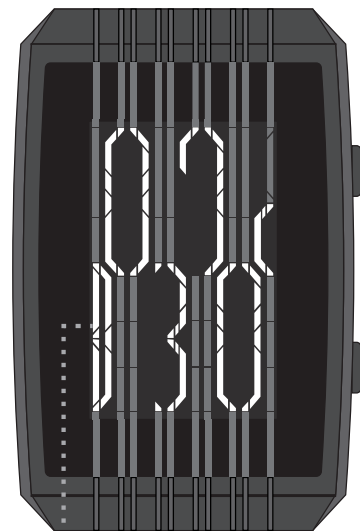

Example 3:

06:15 AM
alarm on

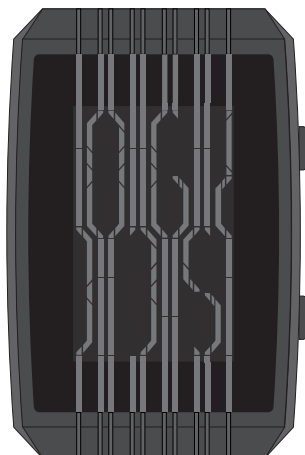

Example 4:

03:45 PM
alarm on

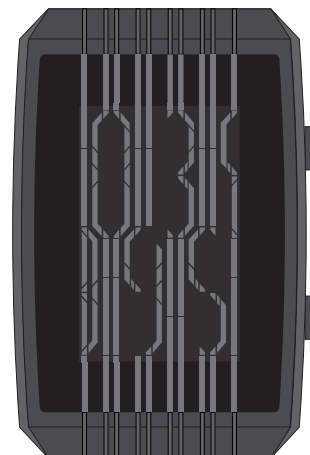

3. How to set the time and animation

- Press and hold button A for 3 seconds to enter setting mode.

Note: after 7 seconds of inactivity setting mode will deactivate.

I. Setting the hour

- The time icon and hour digits will flash when you are in hour setting mode.
- The AM/PM icon in setting mode indicates that you are setting the time in AM or PM.
- Press button B to increase the hours as required.
- Hold button B to increase the hours more quickly.

- press button A to confirm and move to minutes.

Note: after 7 seconds of inactivity setting mode will deactivate.

Example:
05:17 PM
hours setting

hours blinking

time indicator
blinking

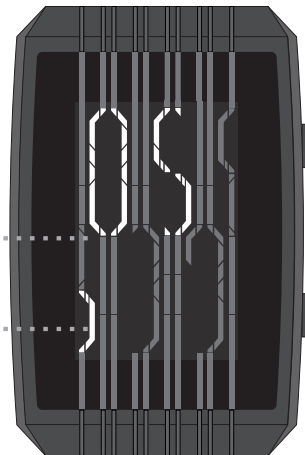

II. Setting the minutes

- The time icon and the minute digits will be flash when you are in minute setting mode.
- Press button B to increase the minutes as required.
- Hold button B to increase the minutes more quickly.

- Press button A to confirm and move to the animation.

Note: after 7 seconds of inactivity setting mode will deactivate.

Example:
05:19 PM
minutes setting

minutes blinking
time indicator
blinking

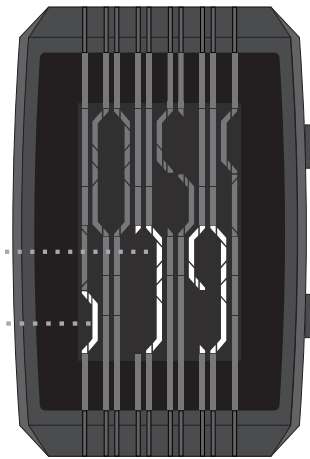

III. Setting animation

- This watch has an animation feature. When set, the animation will appear every two seconds and shows a segment falling from one randomly selected line.

Example 1:
time display
animation on

“falling
segment”

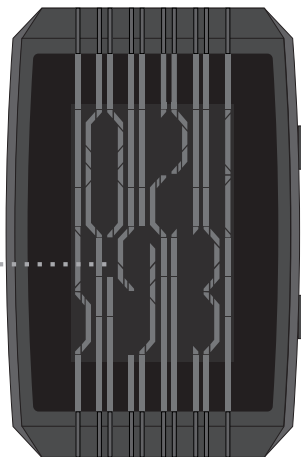

Example 2:
setting mode
animation on

“falling
segment”

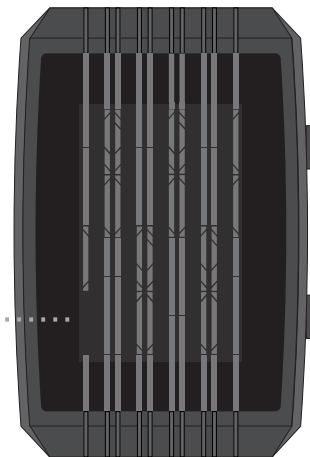

In setting mode, when the animation is on, the line on the left of the display will animate.

- In setting mode, when the animation is off, all the lines will flash.
- Press button B to turn the animation on or off.
- Press button A to confirm and exit setting mode.



4. How to set the date

- Press button B to display the date.
- Press and hold button A for 3 seconds to enter date setting mode.

Note: after 7 seconds of inactivity setting mode will deactivate.

I. Setting the year

- The date icon and the year digits will flash when you are in setting mode.
- Press button B to increase the year as required.
- Hold button B to increase the years more quickly.

- Press button A to confirm and move to month.

Note: after 7 seconds of inactivity setting mode will deactivate.

Example :

2012

years setting

years blinking

date indicator blinking

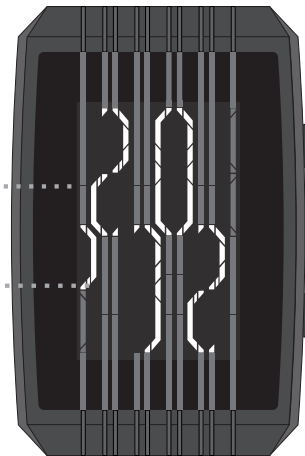

I. Setting the month

- The date icon and the month digits will flash when you are in month setting mode.
- Press button B to increase the month as required.
- Hold button B to increase the month more quickly.

- Press button A to confirm and move to date.

Note: after 7 seconds of inactivity setting mode will deactivate.

Example :
November the 1st
month setting

months blinking

date indicator
blinking

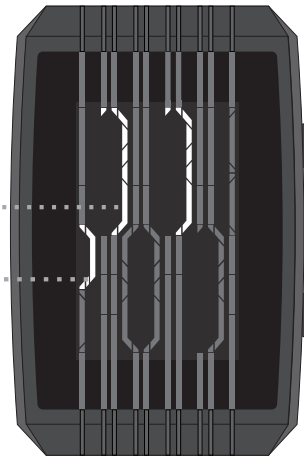

III. Setting the date

- The date icon and the date digits will flash when you are in date setting mode.
- Press button B to increase the date as required.
- Hold button B to increase the date more quickly.

- Press button A to confirm and exit setting mode.

Note: after 7 seconds of inactivity setting mode will deactivate.

Example :
12th
date setting

date indicator
blinking

date blinking

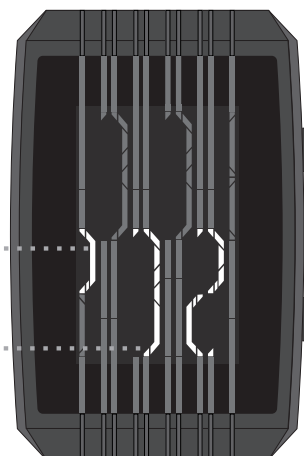

5. How to set the alarm time

- Press button B twice to display the alarm time.
- Hold button A for 3 seconds to enter alarm setting mode.

Note: after 7 seconds of inactivity setting mode will deactivate.

I. Turning the alarm on or off

- The alarm mode icon will start flash.
- Press button B to turn the alarm on or off. The alarm icon indicates that the alarm is on.

Example 1: alarm on
alarm on/off setting

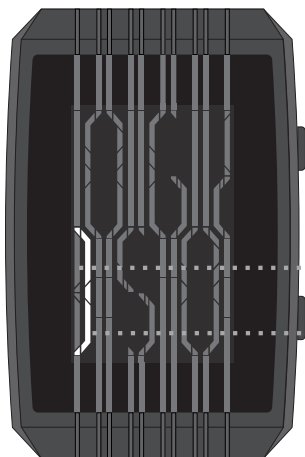

Example 2: alarm off
alarm on/off setting

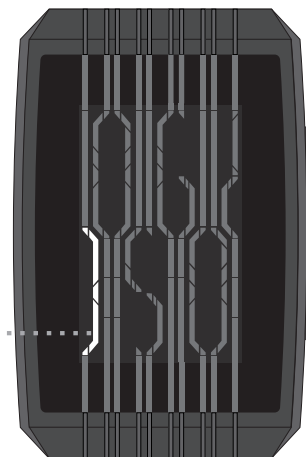

alarm on
indicator
alarm indicator
blinking

Note: after 7 seconds of inactivity setting mode will deactivate.

- Press button A to confirm and move to the hours.

II. Setting the alarm hour

- The alarm icon and the hour digits will flash.
- The AM / PM icon in setting mode indicates that you are setting the time in AM or PM.
- Press button B to increase the hour as required.
- Hold button B to increase the hour more quickly.

- press button A to confirm and move to alarm minutes.

Note: after 7 seconds of inactivity setting mode will deactivate.

Example: 06:50

alarm hours
setting

hours blinking

time indicator
blinking

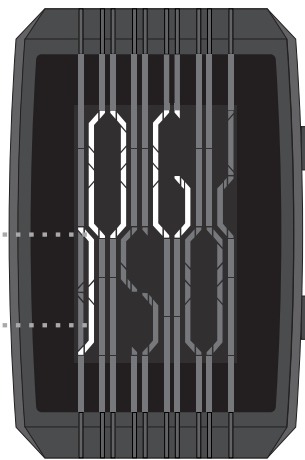

III. Setting the alarm minutes

- The alarm icon and the minute digits will flash.
- Press button B to increase the minutes as required.
- Hold button B to increase the minutes more quickly.

- Press button A to confirm and exit setting mode.

Note: after 7 seconds of inactivity setting mode will deactivate.

Example: 06:55

alarm minutes
setting

hours blinking

time indicator
blinking

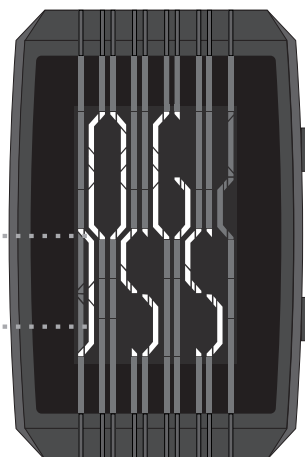

8. User information

I. Battery

- This watch uses a CR2032 replaceable watch battery.
- Battery lifetime will vary depending on use, but is estimated to last for at least one year.
- To maximize battery life you should limit use of the EL backlight.

II. Warranty

- This watch is covered by a 1 year warranty. This warranty does not cover water damage, accidental damage, neglect or unauthorized repair.

III. Caution

- This watch is water resistant to 3ATM. Please do not use the watch in the shower, for swimming or for other water related activities.

SPECIFICATIONS

Case Materials	Stainless Steel
Strap Materials	Stainless Steel
Case Dimensions	33 x 51 x 14.4 mm
Finish	brushed
Maximum Fit Wrist Size	220mm (approx.)
Weight	160g
Display	LCD with EL backlight
Battery	CR2032
Water Resistance	3ATM

