

TITAN BUILDING PRODUCTS TEST REPORT

SCOPE OF WORK

TESTING OF TITAN PRESSURE TREATED WOODEN GUARD WITH ALUMINUM PICKETS TO ASSESS RESISTANCE TO INFILL AND CONCENTRATED LOADS IN AC273

REPORT NUMBER

103643197TOR-005

TEST DATE(S)

02/13/19 - 02/14/19

ISSUE DATE [REVISED DATE]

02/27/19 02/28/19

PAGES

21

DOCUMENT CONTROL NUMBER

GFT-OP-10c (AUGUST 27, 2018)

© 2017 INTERTEK



TEST REPORT FOR TITAN BUILDING PRODUCTS

Report No.: 103643197TOR-005

Date: 02/27/19

REPORT ISSUED TO

TITAN BUILDING PRODUCTS

5450 Canotek Rd Unit 71
Ottawa, ON K1J 9G6
Canada

SECTION 1

SCOPE

Intertek Building & Construction (B&C) was contracted by Titan Building Products, to assess the resistance of their PT Wooden Guard System with Aluminum Pickets to the infill and concentrated loads in **ICC-ES AC273** "Acceptance Criteria for Handrails and Guards", Approved June 2017, Sections 4.2.4 and 4.2.6 respectively.

Testing was conducted at the Intertek test facility in Mississauga, ON, from February 13th 2019 to February 14th 2019.



This report does not constitute certification of this product nor an opinion or endorsement by this laboratory. Intertek B&C will service this report for the entire test record retention period. The test record retention period ends four years after the test date. Test records, such as detailed drawings, datasheets, representative samples of test specimens, or other pertinent project documentation, will be retained for the entire test record retention period.

SECTION 2

SUMMARY OF TEST RESULTS

The Titan PT Wooden Guard System with Aluminum Pickets achieved the results presented in section 10 of this report.

For INTERTEK B&C:

COMPLETED BY:	Tyrone Williams	REVIEWED BY:	Joe DeRose, P. Eng.
	Technician		Project Engineer,
TITLE:	Building Products	TITLE:	Evaluation Services
			
SIGNATURE:		SIGNATURE:	
DATE:	03/28/19	DATE:	02/28/19

This report is for the exclusive use of Intertek's Client and is provided pursuant to the agreement between Intertek and its Client. Intertek's responsibility and liability are limited to the terms and conditions of the agreement. Intertek assumes no liability to any party, other than to the Client in accordance with the agreement, for any loss, expense or damage occasioned by the use of this report. Only the Client is authorized to permit copying or distribution of this report and then only in its entirety. Any use of the Intertek name or one of its marks for the sale or advertisement of the tested material, product or service must first be approved in writing by Intertek. The observations and test results in this report are relevant only to the sample(s) tested. This report by itself does not imply that the material, product, or service is or has ever been under an Intertek certification program.

TEST REPORT FOR TITAN BUILDING PRODUCTS

Report No.: 103643197TOR-005

Date: 02/27/19

SECTION 3

TEST METHOD(S)

The specimens were tested for resistances to the infill and concentrated loads in the following:

- **ICC-ES AC273** "Acceptance Criteria for Handrails and Guards", Approved June 2017. Section 4.2.4 and 4.2.6

SECTION 4

MATERIAL SOURCE/INSTALLATION

Three (3) assembled guard systems were submitted to Intertek directly from the client on the 21st January 2019. The guard systems were installed over one layer of 5/4x 6 cedar deck boards into a 3 in. wood substrate consisting of two (2) layers of 2x12 SPF wood. Samples were not independently selected for testing. Tests were performed at the Intertek laboratory in Mississauga, Ontario.

SECTION 5

EQUIPMENT

Calibration of test equipment was performed by Intertek B&C in accordance with ISO 17025 requirements.

Equipment Calibration		
Instrument/Equipment	Asset #	Calibration Due Date
2K Load Cell with Digital Indicator	280-01-0774	Aug-15-2019
Stop Watch	273-01-1201	Apr-13-2019
Digimatic indicator	280-01-0836	Mar-26-2019
Tape Measure	280-01-1253	Nov-5-2019
Powerfist 24" stroke Hydraulic Ram	N/A	N/A
Electric Hydraulic Pump	N/A	N/A

SECTION 6

LIST OF OFFICIAL OBSERVERS

NAME	COMPANY
Joe DeRose	Intertek B&C
Richard Bergman	Titan Building Products

Note: The above observer(s) witnessed part of or the entire test program.

TEST REPORT FOR TITAN BUILDING PRODUCTS

Report No.: 103643197TOR-005

Date: 02/27/19

SECTION 7

TEST PROCEDURE

Samples were tested in the laboratory under ambient conditions. No specific conditioning parameters were required before testing.

Infill Load Test

The test loads indicated in AC273 section 4.2.4 were applied over a 12 in. x 12 in. square platen normal to the infill at the intersection of the horizontal and vertical center line of the infill and held for one (1) minute, whereupon deflection of the infill at the point of maximum deflection was recorded.

Concentrated Load Test

The concentrated test loads indicated in AC273 section 4.2.6 were applied separately and sequentially at the following locations: vertically and horizontally on the top rail at mid-span between the 6 x 6 posts, horizontally on the top rail adjacent to a 6 x 6 post, horizontally on top of the 4x4 and 6x6 posts. Specified and factored loads were applied over a 4 in. x 4 in. square platen and held for one (1) minute, whereupon deflection was recorded at the point of application of the load. The load applied on the rail adjacent to the post was applied to the opposite post from which the top-of-post-test was performed on.

After release of the load, the system was evaluated for failure, evidence of disengagement and visible cracks in any component.

SECTION 8

TEST CALCULATIONS

Factored loads

The applicable safety factor to be applied was 3.0 based on "Acceptance Criteria for Handrails and Guards", **AC273**, Approved June 2017 Section 4.2.4 and 4.2.6

Deflection Criteria

The top rail and post allowable deflection limits below are based on "Acceptance Criteria for Handrails and Guards", **AC273**, Approved June 2017 Section 4.2.6 (a) and (b)

- When the load is applied at the mid-span of the rail, the total horizontal deflection shall not exceed $(h/24) + (L/96)$.
- In addition, the top rail horizontal mid-span net deflection shall not exceed $(L/96)$

TEST REPORT FOR TITAN BUILDING PRODUCTS

Report No.: 103643197TOR-005

Date: 02/27/19

- When the load is applied at the mid-span of the rail, the vertical deflection shall not exceed ($L/96$)
- When the load is applied on the post at the top rail height the horizontal deflection shall not exceed ($h/12$)

Where:

 H = the distance between the post anchorages and the top of the top rail. L = the rail length between the vertical supports.**SECTION 9****TEST SPECIMEN DESCRIPTION**

The Titan guard assembly, as shown in the Appendix, consisted of two (2) nominal 6x6 end posts and two (2) nominal 4x4 intermediate posts fitted with the Titan Post Anchors for 6x6 and 4x4 posts respectively. The nominal 2x4 pressure treated wood top and bottom rails were fitted vertically between posts. A Titan Plastic Shadow Rail Female Horizontal Connector was fitted to each end of the rails using two (2) #10 x 2 in. flat head wood screws. The rails were subsequently fastened to the Titan plastic Shadow Rail-Male Horizontal Connectors which were screwed to the posts using two (2) #10 x 2 in. flat head wood screws.

A continuous nominal cedar 2x6x210 in. long wood rail-cap was fitted between end posts, creating a "T-shaped" top rail. The rail cap was screwed to the top of the 4x4 post and 2x4 rails. The ends of the rail cap were butted and toenailed into the nominal 6 x 6 post

Fitted between the top and bottom rails were hollow round aluminium pickets held in place via plastic connectors with covers. The connectors were screwed to the rails using one (1) #9 x 1-3/4 in. pan head screw.

As installed, the posts were spaced 72 in. on centre and the height of the guard measured 42 in. from the surface of the cedar deck board to the top of the 2x6 wooden rails.

TEST REPORT FOR TITAN BUILDING PRODUCTS

Report No.: 103643197TOR-005

Date: 02/27/19

The guard system component descriptions and key dimensions are summarized in the table below.

Guard Assembly Components							
Drawing Title/ Part No.	QTY	Part Description	Part Dimensions (Inch)				Reported Material
			Width	Height	length	Nominal Thickness	
TIPR4402/ TIPR4402-Base	2	4x4 post anchor base plate anchored on wood substrate using six (6) - #14 x 4 in. flat head wood screws	7.5	0.6	7.5	0.125	Hot Dip Zinc Steel
TIPR6602/ TIPR6602-Base	2	6x6 post anchor base plate anchored on wood substrate using six (6)- 3/8 in. x 5 in. hot dip galvanized Hex head lag screws.	5	0.6	4.9	0.125	Hot Dip Zinc Steel
No Drawing	2	Nominal 6x6 wood posts installed into 6x6 post anchor using six (6)- 1/2 in. x 5 in. lag screw, with three (3) screws oriented normal to the inward and three (3) screws oriented normal to the outward load of the guard system.	5.4	5.4	43.8	-	Pressure Treated SPF wood
No Drawing	2	Nominal 4x4 wood posts installed into 4x4 post anchor using four(4)- 3/8 in. x 5 in. lag screw	3.4	3.4	40.5	-	Pressure Treated SPF wood
No Drawing	6	Nominal 2x4 wood used for bottom rails and part of top rail.	87	38	67	-	Pressure Treated SPF wood
No Drawing	2	Nominal 2x6 wood used for top rail cap. Screwed to 2x4 rail using #10 x 3-1/4 at 15 in. on center. Screwed to 4 x4 post using four (4)-#10 x 3-1/4 and 6x6 end post using three (3)-#10 x 3-1/4 in. flat head wood screws.	5.4	1.5	210	-	Cedar
No Drawing	42	Picket infill fitted to round connector	Dia.= 3/4		31	0.06	Aluminium
shadow rail- horizontal female	12	Female plastic rail connector	1.5	0.6	3.3		Polycarbonate
shadow rail-Male horizontal connector	12	Male plastic rail connector	1.5	-	3.4		Polycarbonate
Round Connector	84	Round Connector fitted to picket infill	See Drawing				Polycarbonate
Connector cover	84	Decorative cover for picket and round connector.	See Drawing				Polycarbonate

TEST REPORT FOR TITAN BUILDING PRODUCTS

Report No.: 103643197TOR-005

Date: 02/27/19

**SECTION 10
TEST RESULTS**

Load Type/Location		Applied test load (lbf)	Deflection at test Load (inch)	Maximum allowable deflection at test load (inch)	Applied factored Load (lbf)	Test Results/observation
Guard Assembly –Sample One (1)						
In-fill Load applied over a 1ft.sq area normal to the infill		50	0.17	Not Required	150	Pass
Vertical concentrated load Applied Mid-Span to the top of the railing system		200	0.08	0.70	600	Pass
Horizontal load Test applied at the minimum required height of the guard	Top Rail Mid-Span	200	0.87 (Total) 0.12 (Net)	2.45 (total) 0.70 (Net)	600	Pass
	Adjacent to post	200	1.06	Not Required	600	Pass
	Top of 4x4 post	200	1.14	3.5	600	Pass
	Top of 6 x6 Post (end post)	200	1.46	3.5	600	Pass
Guard Assembly –Sample Two (2)						
In-fill Load applied over a 1ft.sq area normal to the infill		50	0.16	Not Required	150	Pass
Vertical concentrated load Applied Mid-Span to the top of the railing system		200	0.08	0.70	600	Pass
Horizontal load Test applied at the minimum required height of the guard	Top Rail Mid-Span	200	0.87 (Total) 0.16 (Net)	2.45 (total) 0.70 (Net)	600	Pass
	Adjacent to post	200	0.98	Not Required	600	Pass
	Top of 4x4 post	200	0.87	3.5	600	Pass
	Top of 6x 6 Post (end post)	200	0.98	3.5	600	Pass
Guard Assembly –Sample Three (3)						
In-fill Load applied over a 1ft.sq area normal to the infill		50	0.24	Not Required	150	Pass
Vertical concentrated load Applied Mid-Span to the top of the railing system		200	0.08	0.70	600	Pass
Horizontal load Test applied at the minimum required height of the guard	Top Rail Mid-Span	200	0.79 (Total) 0.08 (Net)	2.45 (total) 0.70 (Net)	600	Pass (Max load=1440 lbf)
	Adjacent to post	200	1.77	Not Required	600	Pass
	Top of 4x4 post	200	0.94	3.5	600	Pass
	Top of 6x6 Post (end post)	200	1.42	3.5	600	Pass

TEST REPORT FOR TITAN BUILDING PRODUCTS

Report No.: 103643197TOR-005

Date: 02/27/19

SECTION 11

CONCLUSION

Intertek has conducted testing for Titan Building Products, to assess the resistance of their Wooden PT Guard System with Aluminum Picket infill and concentrated loads as prescribed in **ICC-ES AC273** "Acceptance Criteria for Handrails and Guards", Approved June 2017, Sections 4.2.4 and 4.2.6 respectively.

The guard system, using the components detailed in Section 9, achieved the results presented in section 10 of this report. Applicable load safety factors were applied as detailed in this report.

The conclusions of this test report may not be used as part of the requirements for Intertek product certification. Authority to Mark must be issued for a product to become certified.

TEST REPORT FOR TITAN BUILDING PRODUCTS

Report No.: 103643197TOR-005

Date: 02/27/19

SECTION 12 PHOTOGRAPHS

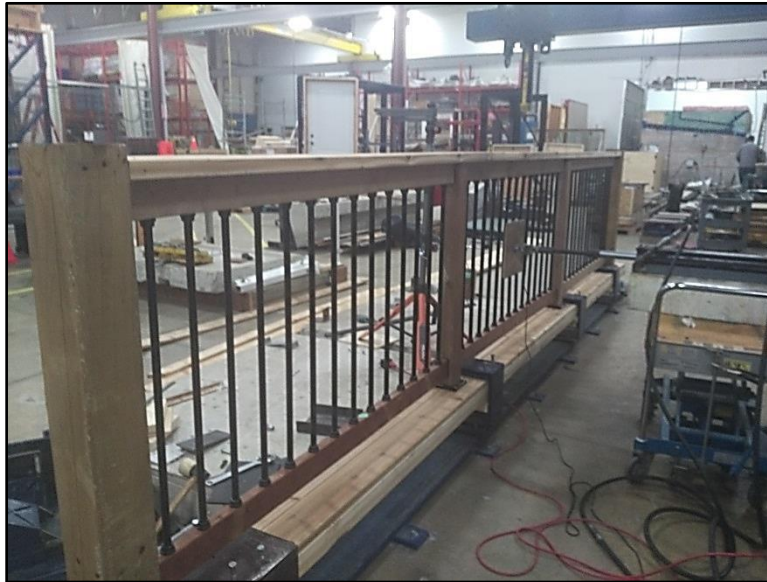

Photo No. 1
Infill Load Test

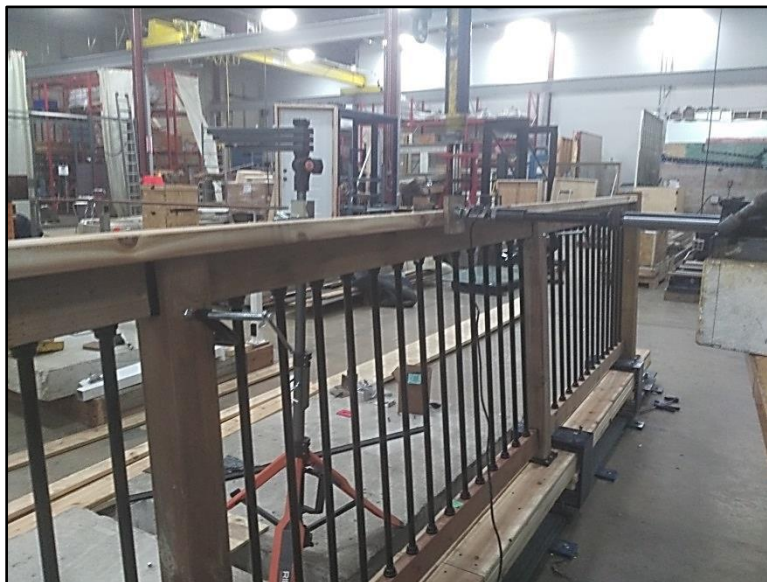

Photo No. 2
Top Rail Horizontal Load Test

TEST REPORT FOR TITAN BUILDING PRODUCTS

Report No.: 103643197TOR-005

Date: 02/27/19



Photo No. 3
Vertical Top Rail Load Test



Photo No. 4
Top of 4x4 Post

TEST REPORT FOR TITAN BUILDING PRODUCTS

Report No.: 103643197TOR-005

Date: 02/27/19



Photo No. 5
Adjacent to End Post



Photo No. 6
Top of the End-Post

TEST REPORT FOR TITAN BUILDING PRODUCTS

Report No.: 103643197TOR-005

Date: 02/27/19

SECTION 13 DRAWINGS

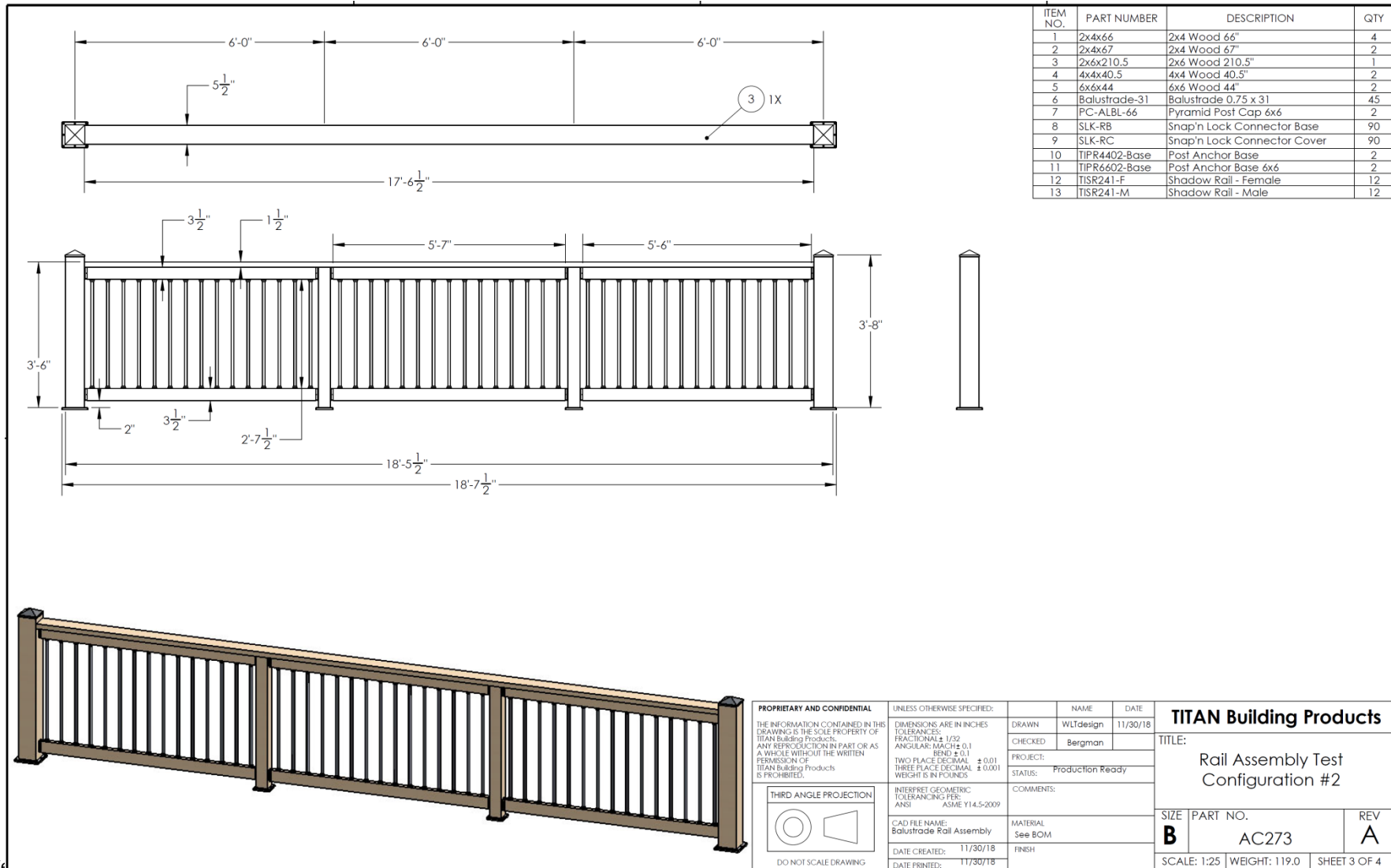

<p>PROPRIETARY AND CONFIDENTIAL</p> <p>THE INFORMATION CONTAINED IN THIS DRAWING IS THE SOLE PROPERTY OF TITAN Building Products. ANY REPRODUCTION IN PART OR AS A WHOLE WITHOUT THE WRITTEN PERMISSION OF TITAN Building Products IS PROHIBITED.</p>	<p>UNLESS OTHERWISE SPECIFIED:</p> <p>DIMENSIONS ARE IN INCHES</p> <p>TOLERANCES:</p> <p>FRACTIONAL: ± 1/32</p> <p>ANGULAR: MACH: 0.1</p> <p>BEND: ± 0.1</p> <p>TWO PLACE DECIMAL: ± 0.01</p> <p>THREE PLACE DECIMAL: ± 0.001</p> <p>WEIGHT IS IN POUNDS.</p>	<p>NAME</p> <p>DATE</p>	<p>TITAN Building Products</p> <p>TITLE:</p> <p>Rail Assembly Test Configuration #2</p>	
	<p>CAD FILE NAME:</p> <p>Balustrade Rail Assembly</p>	<p>DRAWN</p> <p>WLTdesign</p> <p>11/30/18</p>		<p>PROJECT:</p> <p>Production Ready</p>
	<p>DATE CREATED:</p> <p>11/30/18</p>	<p>CHECKED</p> <p>Bergman</p>		<p>STATUS:</p> <p>Production Ready</p>
	<p>DATE PRINTED:</p> <p>11/30/18</p>	<p>COMMENTS:</p>		<p>COMMENTS:</p>
<p>THIRD ANGLE PROJECTION</p> <p>DO NOT SCALE DRAWING</p>	<p>INTERPRET GEOMETRIC TOLERANCING PER: ANS</p> <p>ASME Y14.5-2009</p>	<p>MATERIAL</p> <p>See BOM</p>	<p>SIZE</p> <p>B</p>	
		<p>FINISH</p>	<p>PART NO.</p> <p>AC273</p>	
			<p>REV</p> <p>A</p>	
			<p>SCALE: 1:25</p>	
			<p>WEIGHT: 119.0</p>	
			<p>SHEET 3 OF 4</p>	

TEST REPORT FOR TITAN BUILDING PRODUCTS

Report No.: 103643197TOR-005

Date: 02/27/19

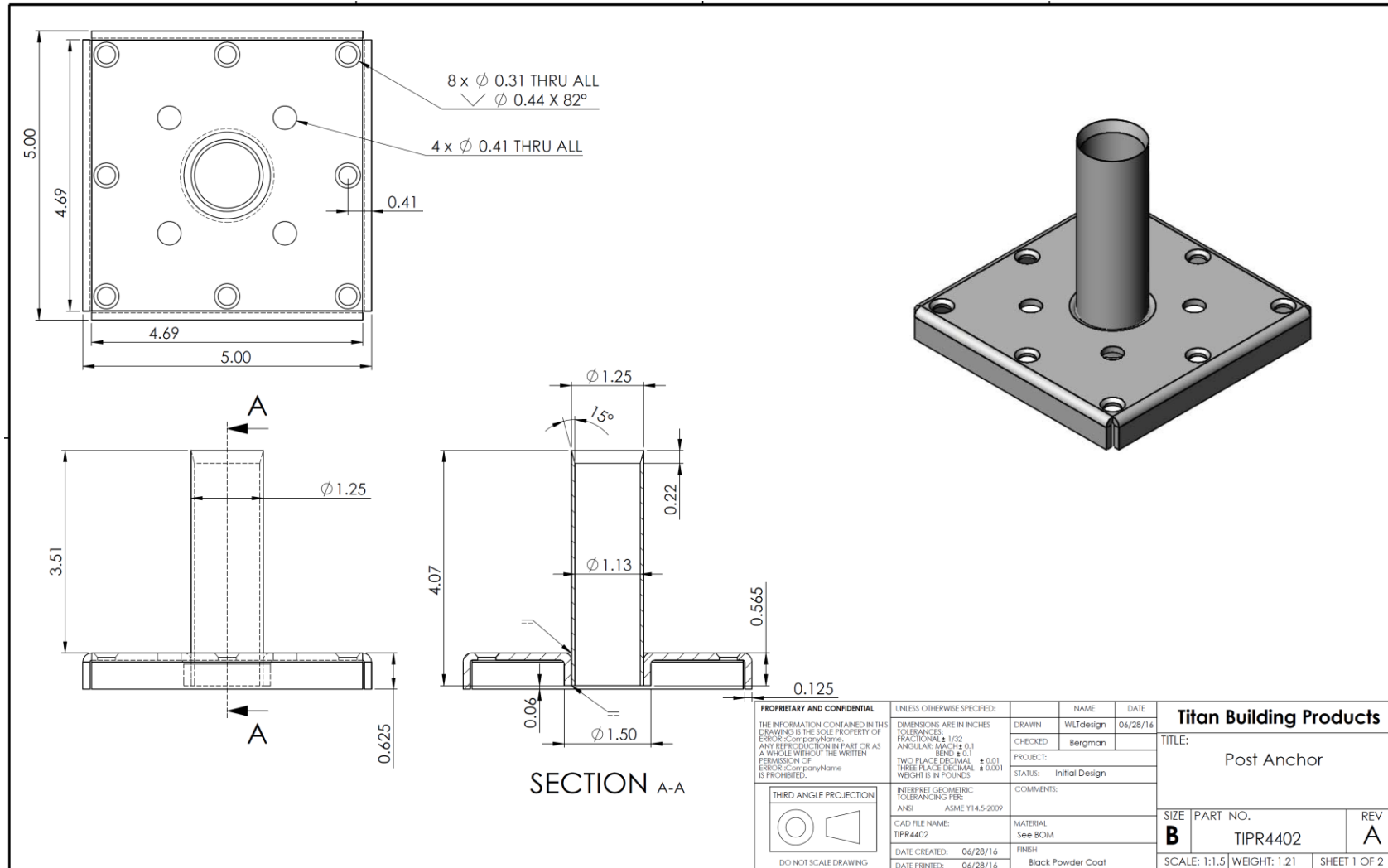

TEST REPORT FOR TITAN BUILDING PRODUCTS

Report No.: 103643197TOR-005

Date: 02/27/19

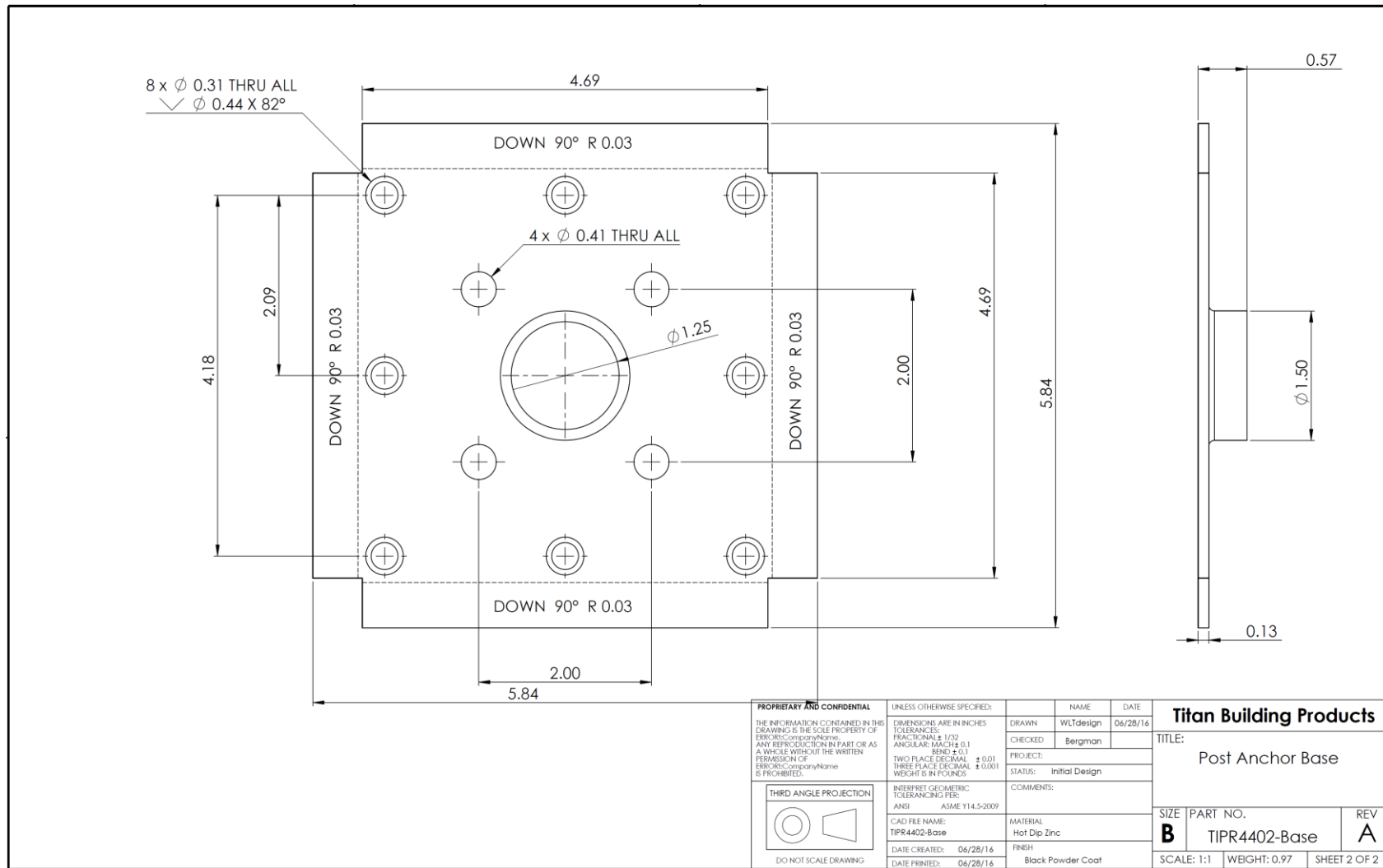

TEST REPORT FOR TITAN BUILDING PRODUCTS

Report No.: 103643197TOR-005

Date: 02/27/19

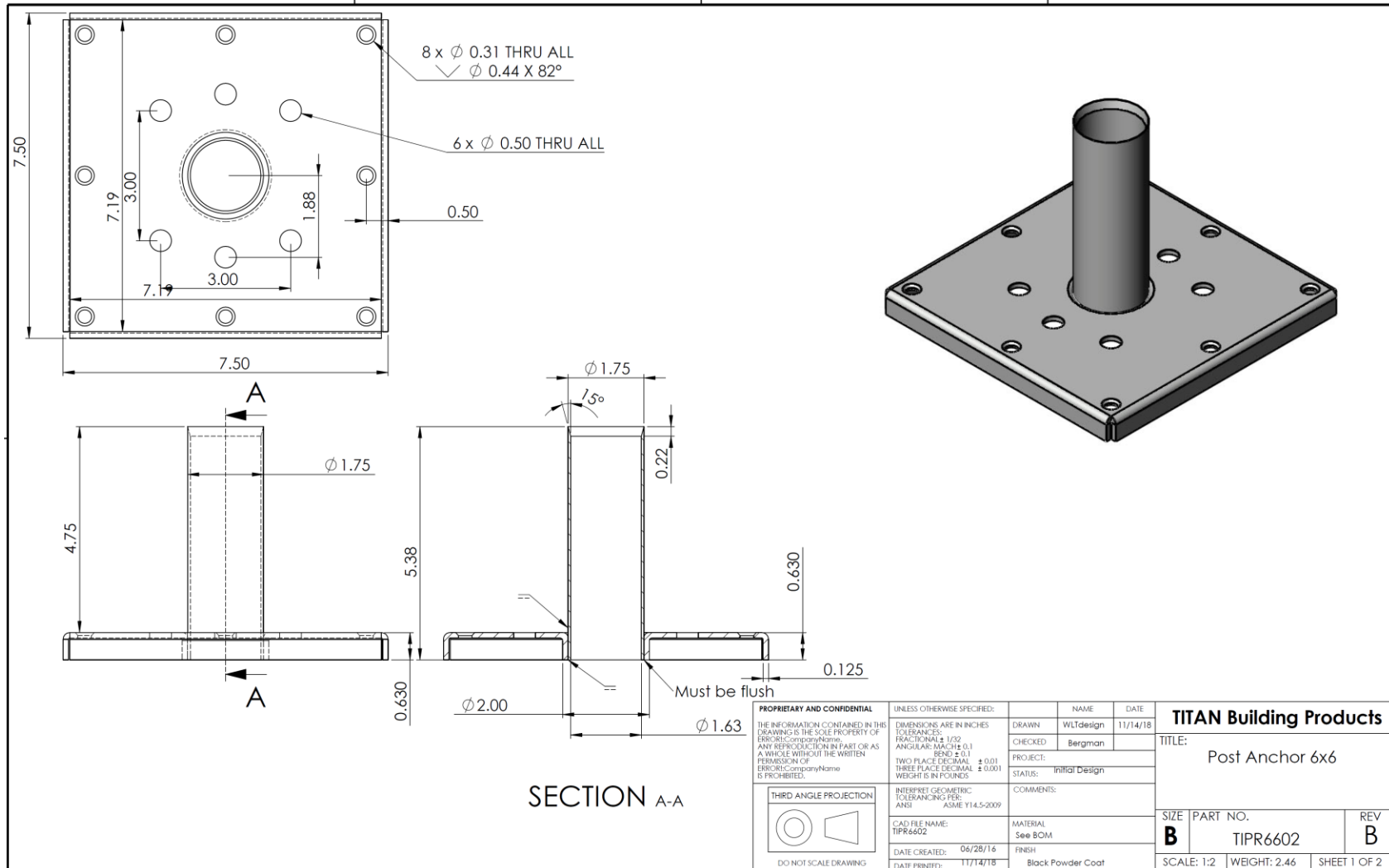

TEST REPORT FOR TITAN BUILDING PRODUCTS

Report No.: 103643197TOR-005

Date: 02/27/19

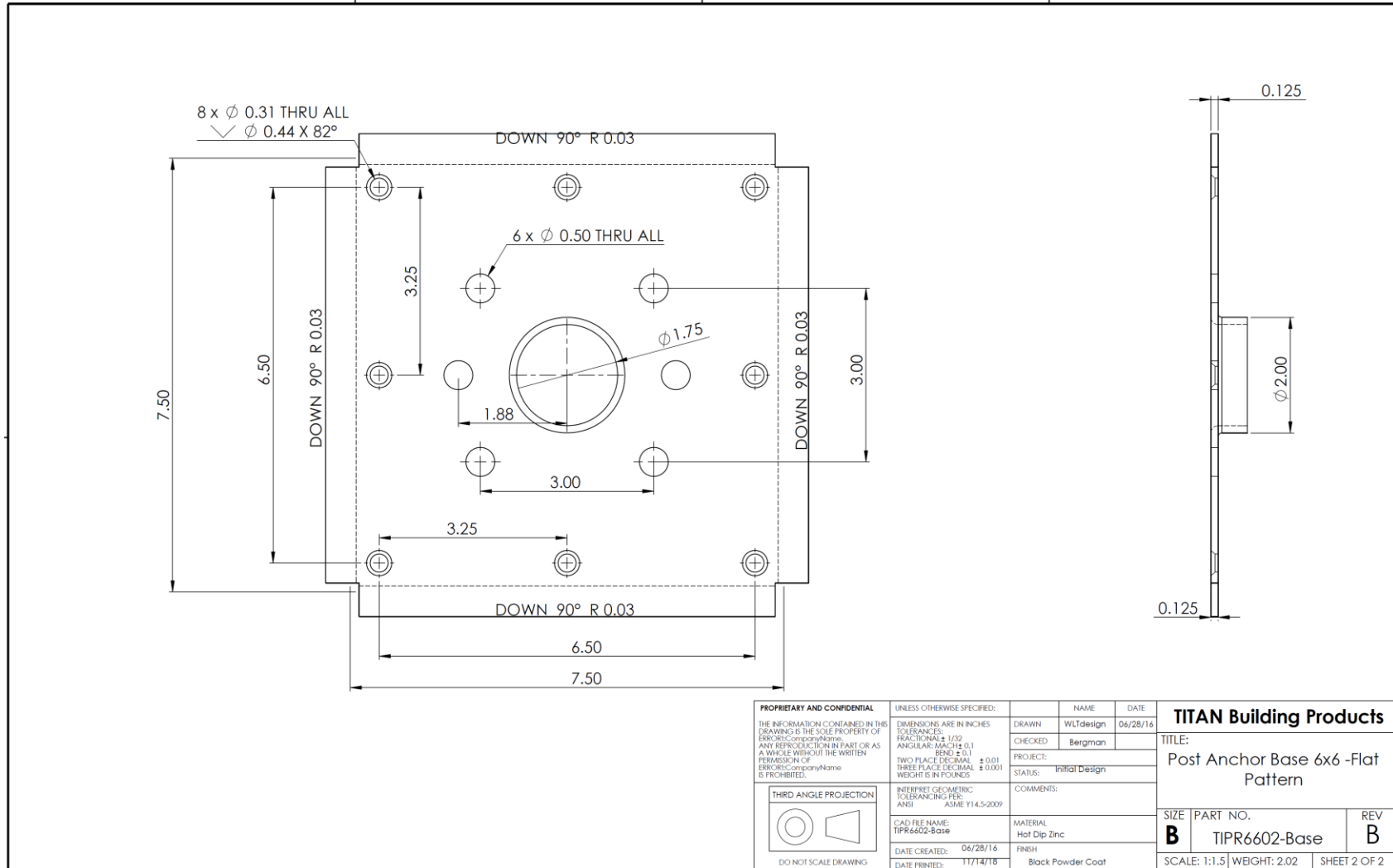

PROPRIETARY AND CONFIDENTIAL THE INFORMATION CONTAINED IN THIS DRAWING IS THE SOLE PROPERTY OF INTERTEK. ANY REPRODUCTION IN PART OR AS A WHOLE WITHOUT THE WRITTEN PERMISSION OF INTERTEK IS PROHIBITED.	UNLESS OTHERWISE SPECIFIED:	NAME	DATE	TITAN Building Products TITLE: Post Anchor Base 6x6 -Flat Pattern
	DIMENSIONS ARE IN INCHES TOLERANCES: FRACTIONAL \pm 1/32 ANGULAR: MACH \pm 0.1 REED \pm 0.1 TWO PLACE DECIMAL \pm 0.01 THREE PLACE DECIMAL \pm 0.001 WEIGHT IS IN POUNDS	DRAWN	WLTdesign	
THIRD ANGLE PROJECTION DO NOT SCALE DRAWING	INTERPRET GEOMETRIC TOLERANCING PER: ASME Y14.5-2009	CHECKED	Bergman	SIZE PART NO. REV B TIPR6602-Base B
	CAD FILE NAME: TIPR6602-Base	PROJECT: STATUS: Initial Design	MATERIAL: Hot Dip Zinc	
DATE CREATED: 06/28/16 DATE PRINTED: 11/7/17	FINISH: Black Powder Coat	SCALE: 1:1.5 WEIGHT: 2.02 SHEET 2 OF 2		

TEST REPORT FOR TITAN BUILDING PRODUCTS

Report No.: 103643197TOR-005

Date: 02/27/19

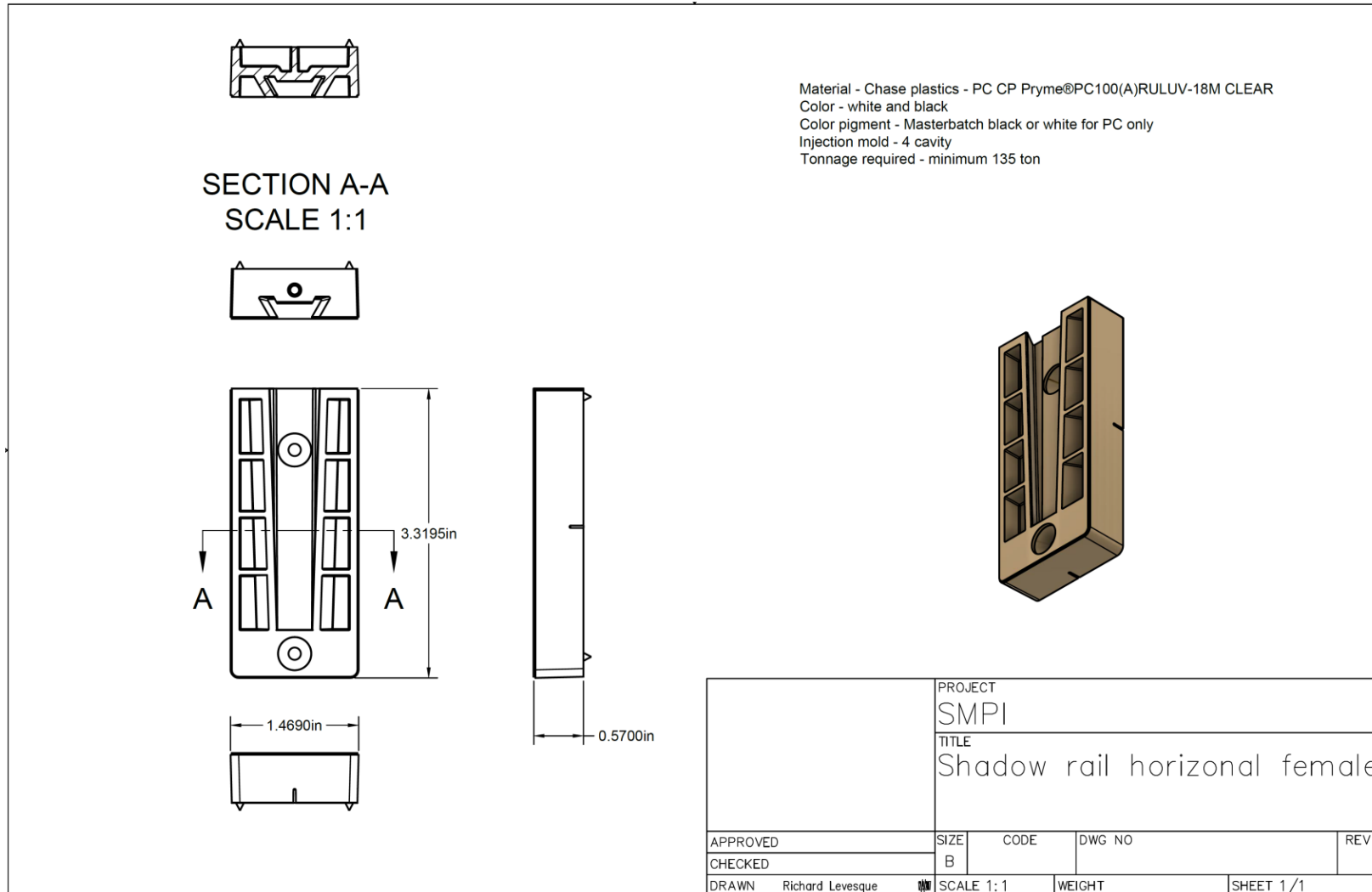

TEST REPORT FOR TITAN BUILDING PRODUCTS

Report No.: 103643197TOR-005

Date: 02/27/16

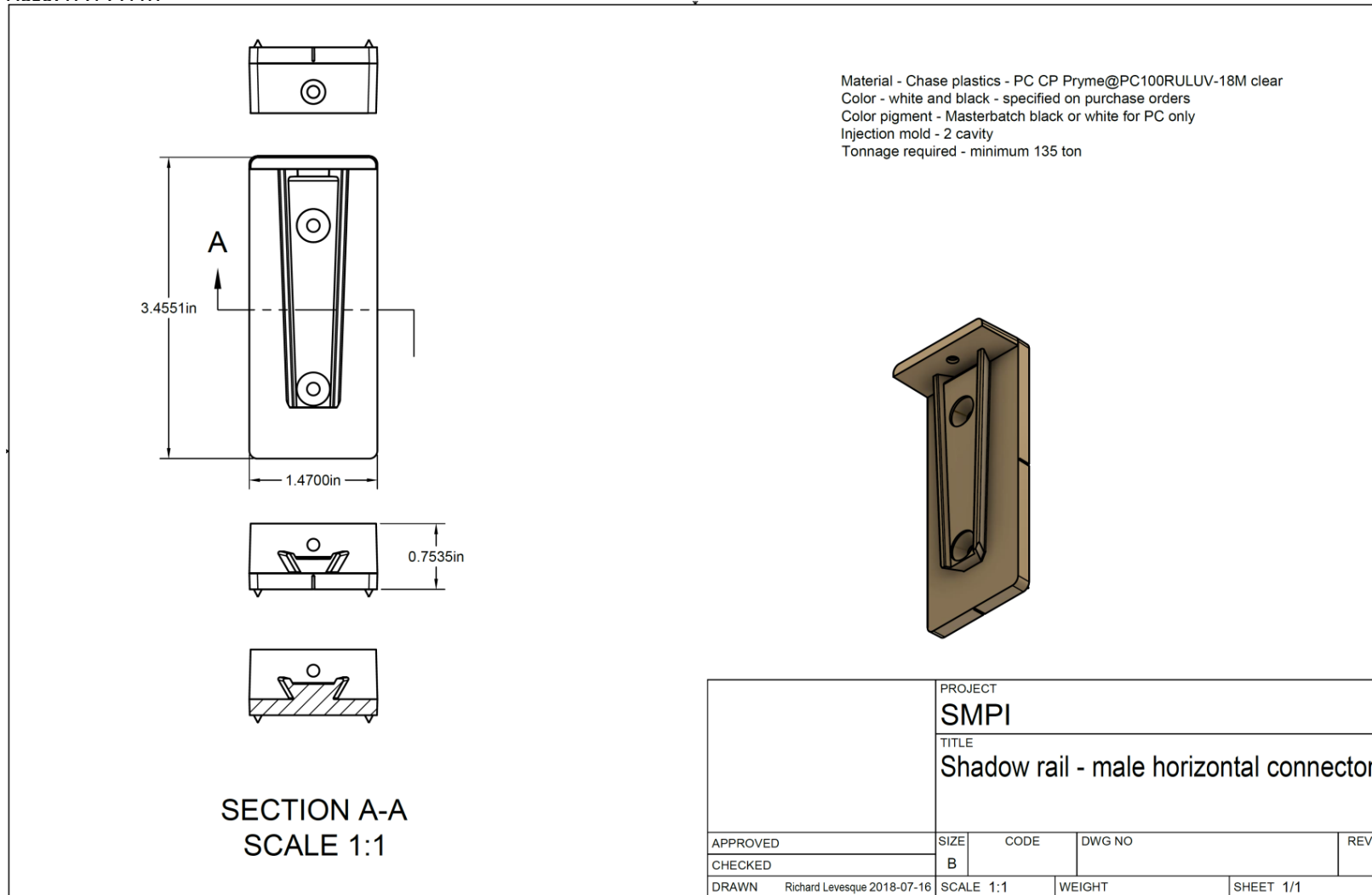

TEST REPORT FOR TITAN BUILDING PRODUCTS

Report No.: 103643197TOR-005

Date: 02/27/19

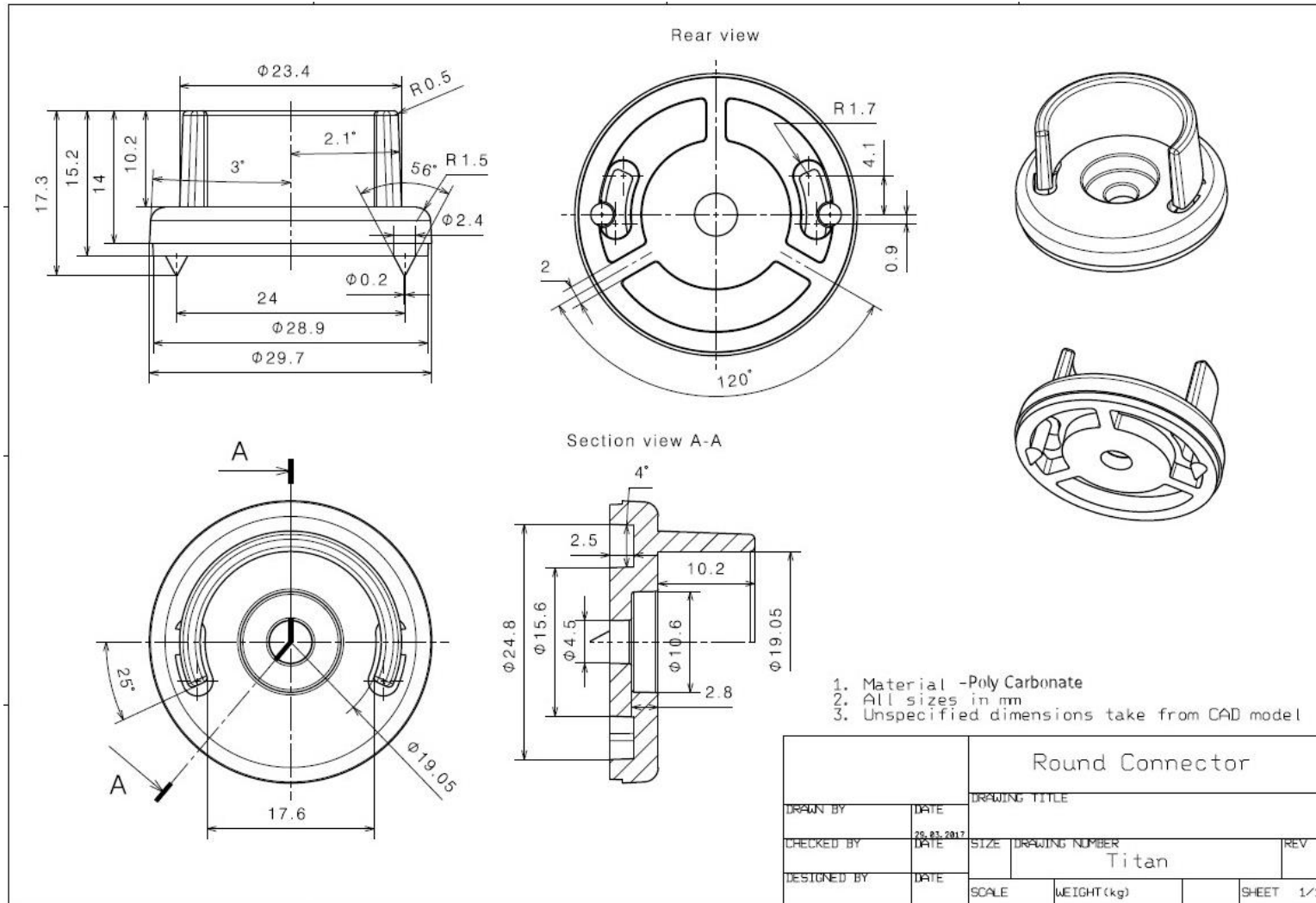

TEST REPORT FOR TITAN BUILDING PRODUCTS

Report No.: 103643197TOR-005

Date: 02/27/19

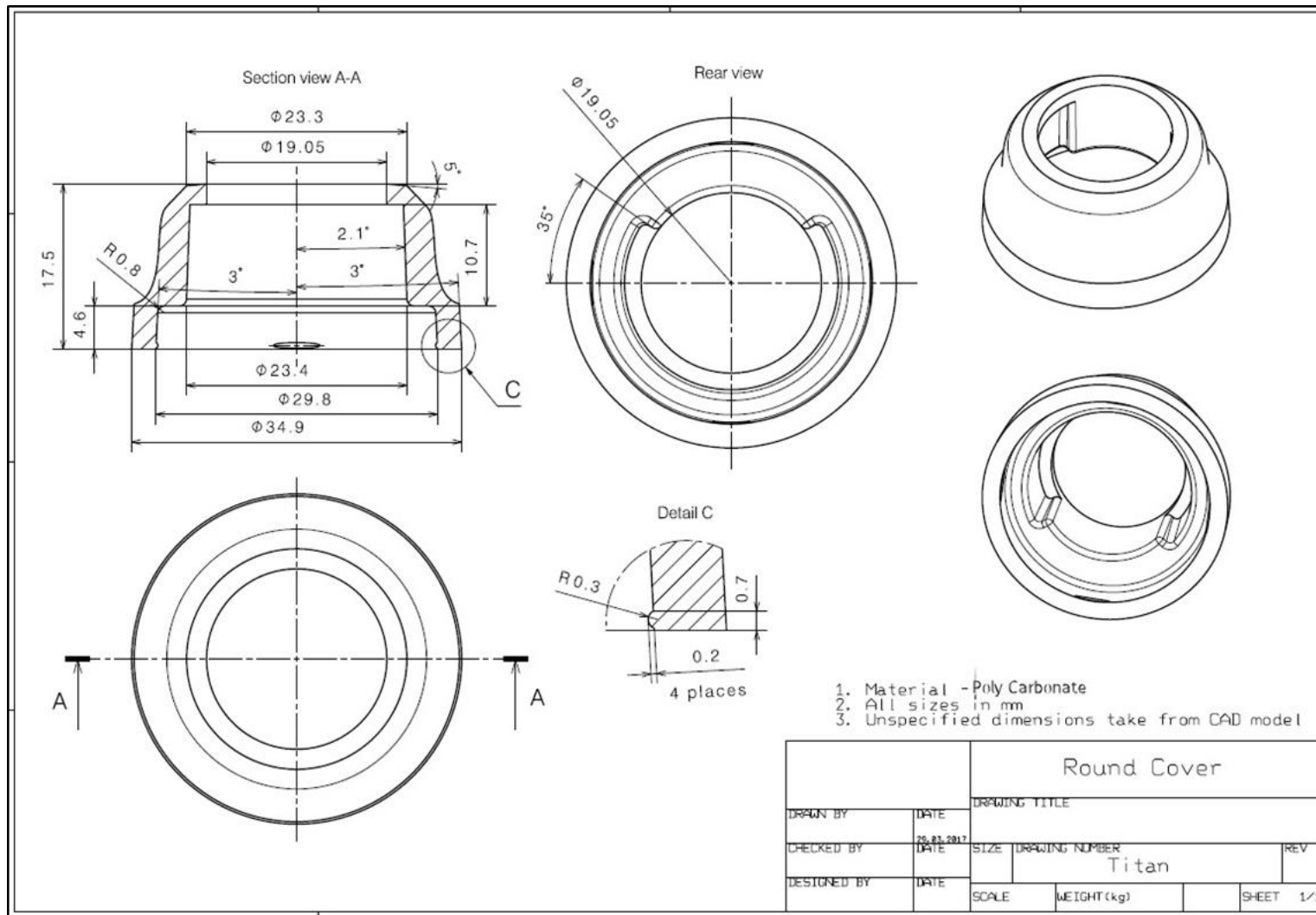



Total Quality. Assured.

6225 Kenway Dr.
Mississauga, ON, L5T 2L3

Telephone: 905-678-7820
Facsimile: 905-678-7131
www.intertek.com/building

TEST REPORT FOR TITAN BUILDING PRODUCTS

Report No.: 103643197TOR-005

Date: 02/27/19

SECTION 14

REVISION LOG

REVISION #	DATE	PAGES	REVISION
0	02/27/19	21	Original Report Issue
1	02/28/19	2	Correction of Client's Address