

# R45 AND R45 DISC HUB SERVICE TOOL MANUAL

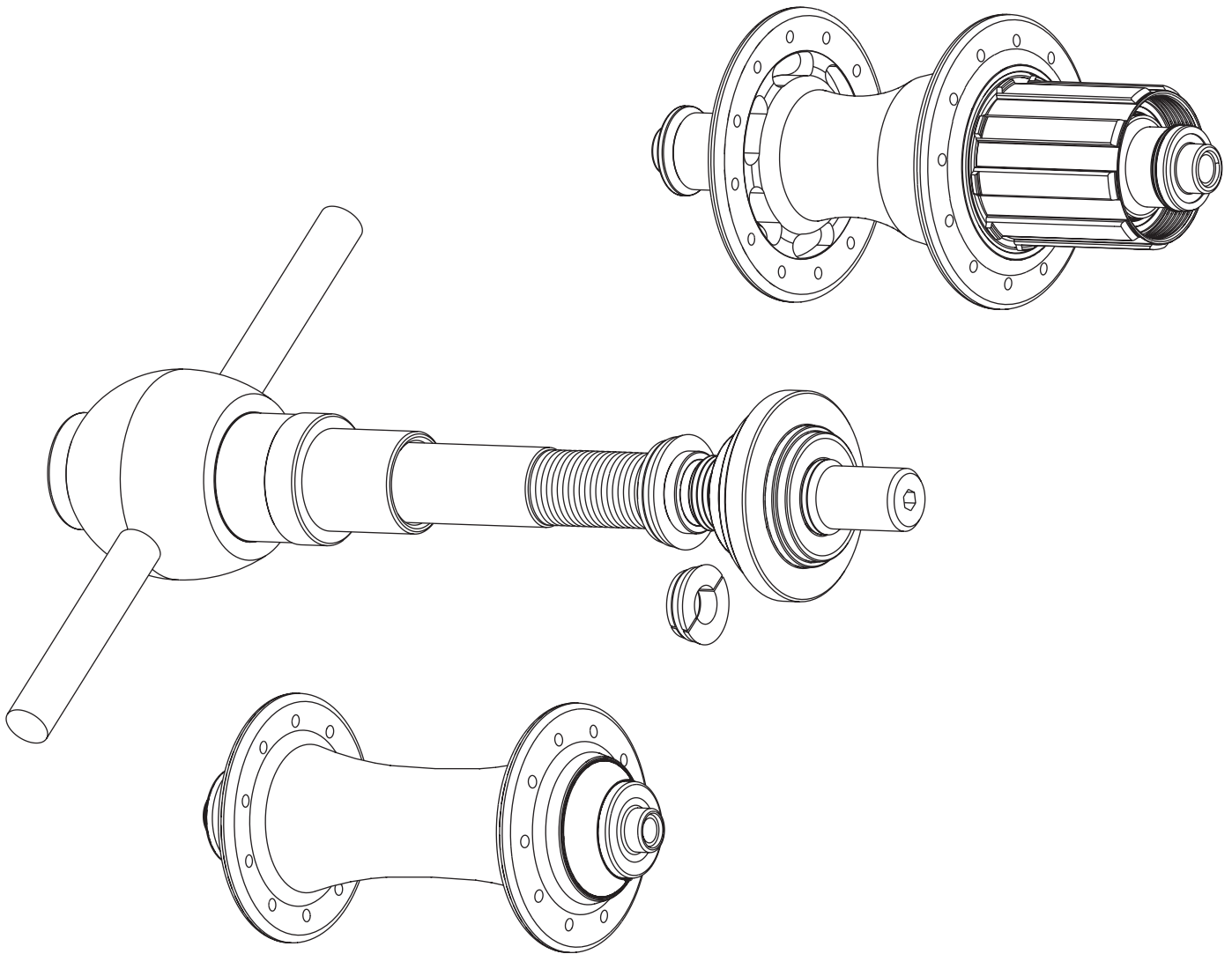

**CHRIS KING**<sup>®</sup>  
PRECISION COMPONENTS

# R45 DISC FRONT

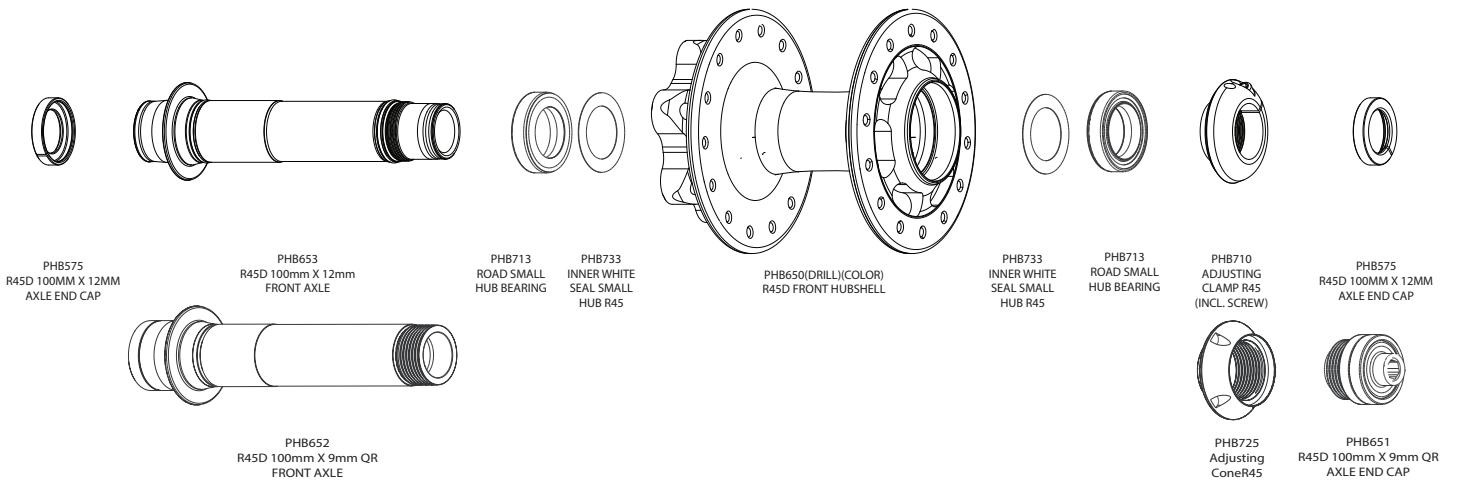

## R45D FRONT HUB ASSEMBLY

REV. 8/4/2015, BY E. NEWTON

**CHRIS KING**<sup>®</sup>  
PRECISION COMPONENTS

# R45 DISC REAR

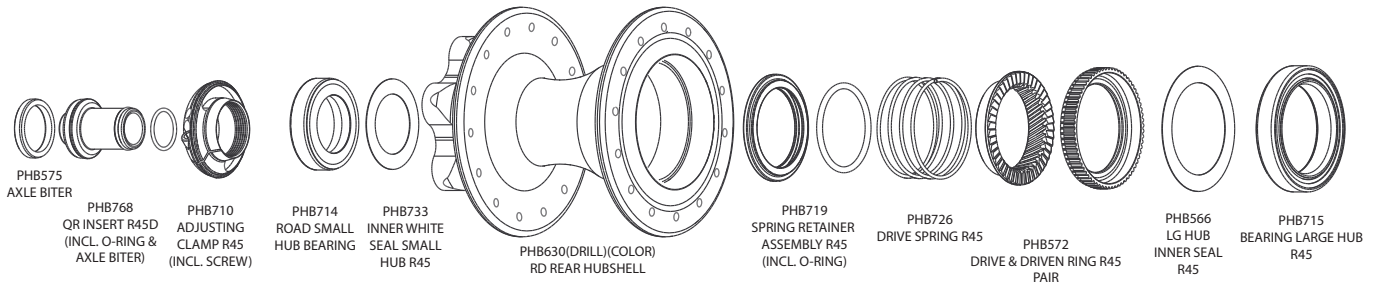

## SHIMANO-11SPD-COMPATIBLE

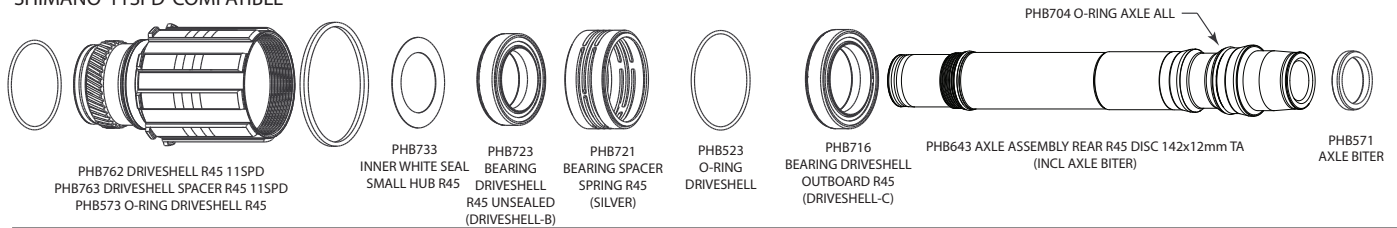

## SHIMANO-11SPD-COMPATIBLE

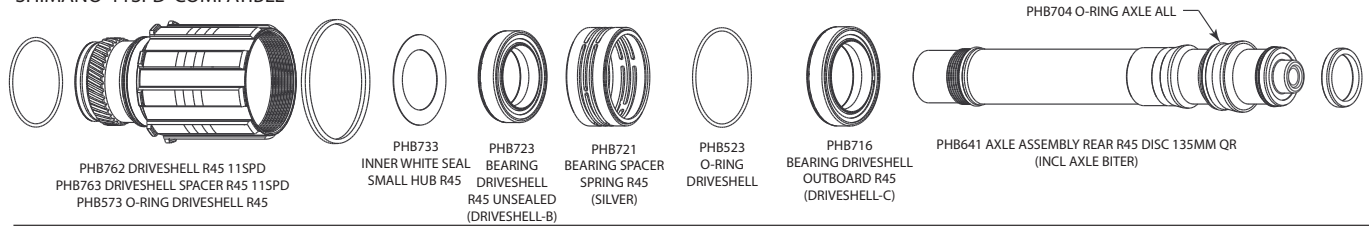

## CAMPAGNOLO-COMPATIBLE

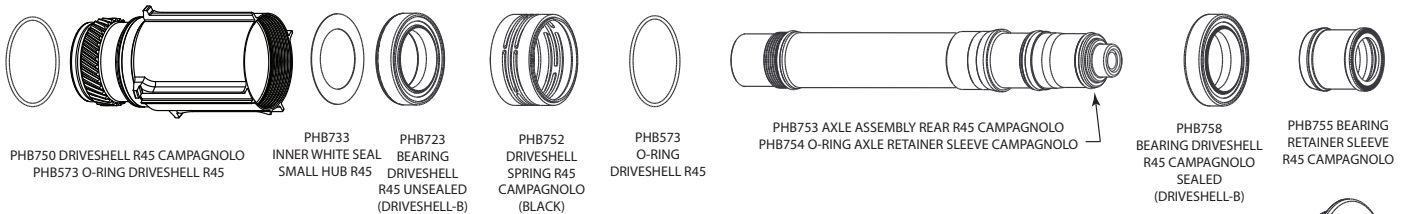

## R45D REAR HUB ASSEMBLY

REV. 7/21/2015, BY E. NEWTON

**CHRIS KING**  
PRECISION COMPONENTS

CASSETTE LOCK RING ALUMINUM CAMPAGNOLO  
PHB756 - 11 TOOTH  
PHB757 - 12 TOOTH

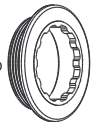

# R45 FRONT

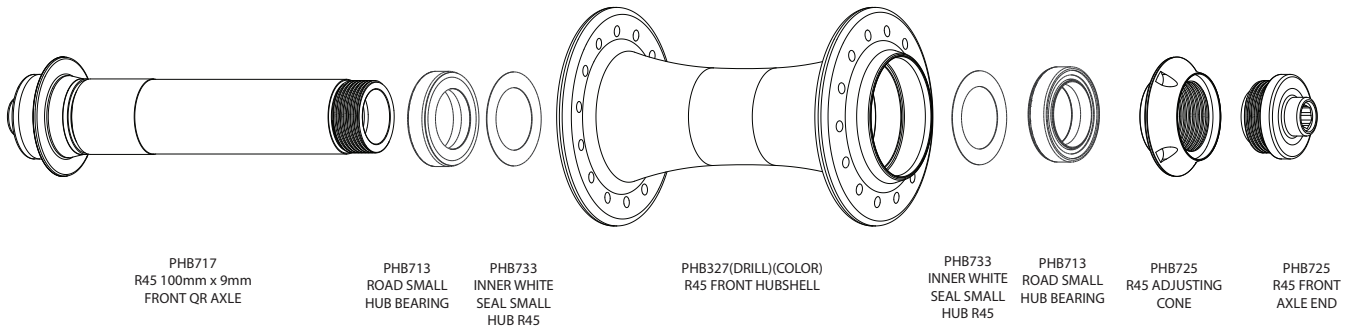

R45 REAR HUB ASSEMBLY  
REV. 8/4/2015, BY E. NEWTON

**CHRIS KING**<sup>®</sup>  
PRECISION COMPONENTS

# R45 REAR

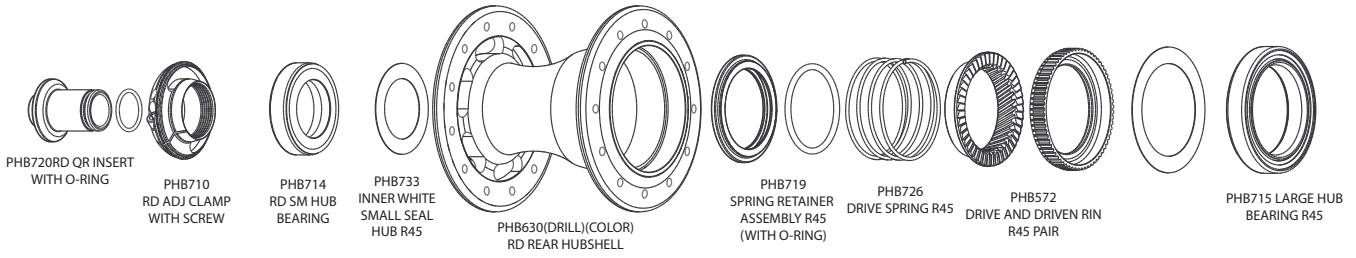

## SHIMANO-11SPD-COMPATIBLE

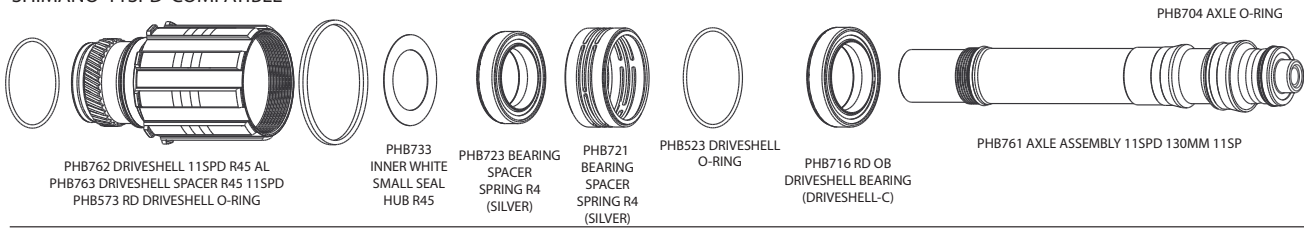

## CAMPAGNOLO-COMPATIBLE

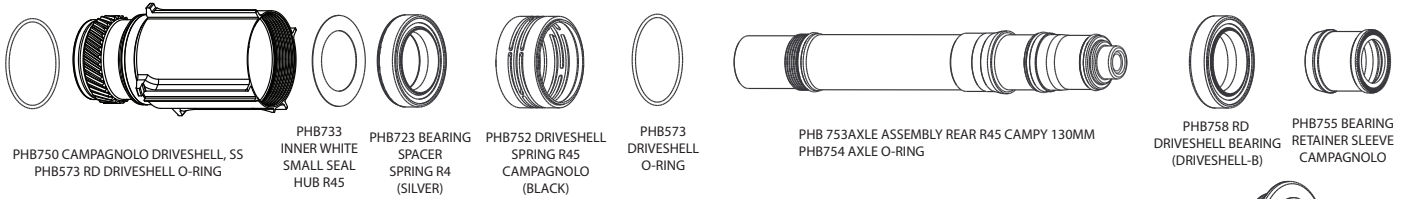

## R45 REAR HUB ASSEMBLY

REV. 2/4/2015, BY E. NEWTON

**CHRIS KING**  
PRECISION COMPONENTS®



## R45 and R45 Disc Hub Specifications

| Hub Type                    | Axle Type | Axle Width (mm) | Flange Diameter Drive Side and non-Drive Side(mm) | Center to Flange Drive Side (mm) | Center to Flange Non-Drive Side (mm) | Frame Attachment Options | Available Spoke Hole Drilling | Upgrade and Conversion Options | Weight – Steel (grams) | Weight – Ceramic (grams) |
|-----------------------------|-----------|-----------------|---|----------------------------------|--------------------------------------|--------------------------|-------------------------------|--------------------------------|------------------------|--------------------------|
| R45 Front                   | two piece | 100             | 39.8  | 34.8                             | 34.8                                 | QR                       | 16, 18, 20, 24, 28, 32        | -                              | 103                    | 99                       |
| R45 Rear                    | one piece | 130             | 51.0  | 17.0                             | 34.3                                 | QR                       | 20, 24, 28, 32                | 1                              | 224                    | 218                      |
| R45 Campagnolo Rear         | one piece | 130             | 51.0  | 17.0                             | 36.3                                 | QR                       | 20, 24, 28, 32                | -                              | 240 <sup>a</sup>       | 231 <sup>a</sup>         |
| R45 Disc QR Front           | two piece | 100             | 57.4  | 30.6                             | 22.3                                 | QR                       | 24, 28, 32                    | 2                              | 162                    | 158                      |
| R45 Disc 12mm TA Front      | two piece | 100             | 57.4  | 30.6                             | 23.3                                 | 12mm TA                  | 24, 28, 32                    | -                              | NA                     | NA                       |
| R45 Disc QR Rear            | one piece | 135             | 57.4  | 19.3                             | 34.3                                 | QR                       | 24, 28, 32                    | 3                              | 276                    | 271                      |
| R45 Disc Campagnolo QR Rear | one piece | 135             | 57.4  | 19.3                             | 34.3                                 | QR                       | 24, 28, 32                    | -                              | 295 <sup>a</sup>       | 286 <sup>a</sup>         |
| R45 Disc 142 x 12mm Rear    | one piece | 142             | 57.4  | 35.4                             | 19.6                                 | 12mm TA                  | 24, 28, 32                    | -                              | NA                     | NA                       |

### Weight Details

<sup>a</sup> Campagnolo hubs come with an 11-tooth lock ring (5.5g). Optional 12-tooth lock ring available aftermarket.

### Wheel Building Specifications

Spoke Gauge: 13, 14, or 15 gauge

R45 Lacing Pattern: Radial Lacing is an acceptable pattern for front wheels and the non-drive side of rear hubs. Drive side of rear hubs must be 2-or-more cross

R45 Disc Lacing Pattern: 2-or-more cross

Spoke Hole Diameter: 2.5mm

Spoke Tension: Should not exceed 120kgf (1200N)

Spoke Tension for Radial Lacing: Should not exceed 90kgf (900N)

### Upgrade and Conversion Options

1. Convertible to Campagnolo driveshell, requires a kit and an axle

2. Convertible to 12mm TA, requires an axle

3. Convertible to 142x12mm TA, requires an axle

## **A NOTE ON THIS MANUAL**

Chris King R45 and R45 Disc hubs require care and overhaul procedures that are different from other Chris King hubs. Be sure to thoroughly read and understand the R45 and R45 Disc Disc overhaul procedure before servicing R45 and R45 Disc Disc hubs. We recommend that these hub overhaul procedures be performed by a professional bicycle mechanic.

## **GENERAL SETUP**

### **CASSETTES**

The aluminum driveshells of the rear hubs are softer than the steel shells, and should only be used in conjunction with “spidered”-style cassettes. Avoid using individual cog-style cog sets with aluminum driveshells. We recommend using our aluminum or Ti cog lock rings when installing 9 and 10 speed cassettes. Our lock rings feature longer threads to provide a more secure engagement with the driveshell threads. 12t Campagnolo lockrings work with 12t-and-larger small cassette cogs.

### **FRAME PREPARATION**

Check frame and fork dropouts to ensure that they are parallel to each other. Use an appropriate tool made by a reputable bicycle tool manufacturer. Unparallel dropouts may damage or compromise the performance of your new hub.

When using any Chris King products in conjunction with other manufacturers’ parts, be sure to follow other manufacturers’ instructions and recommendations.

### **NEVER USE THREAD LOCKING COMPOUNDS**

Thread locking compounds are not an acceptably reliable substitution for loose threads or press fits. All Chris King components are engineered and manufactured to exacting tolerances to eliminate the need for thread locking compounds. Please refer to the bearing preload adjustment procedure to properly adjust hubs.

### **DROPOUT SPACING AND RETENTION DEVICES**

R45 and R45 Disc Disc front hubs are designed to work with 100mm fork drop out spacing only, please use the appropriate axle for your type of retention, quick release or thru-axle. Do not attempt to use your hub with any other dropout spacing. Do not modify or alter the axle.

R45 and R45 Disc Disc rear hubs are designed to work with a variety of frame dropouts and spacing. Do not attempt to use your hub with any dropout spacing not specified for your axle type. Each axle is designed to be used exclusively with it. Do not modify or alter the axle.

## **WHEEL BUILDING**

Proper wheel building technique is essential in creating a strong wheel. Wheel building is a skill that requires proper training and specialized tools and should be done by a trained professional.

For wheel building dimensions, see “Hub specifications and wheel building” table.

### **RADIAL LACING**

The R45 and R45 Disc Disc hubshell have been designed with the most common lacing patterns in mind. We recommend special care be taken when building and using radial laced wheels. The undersides of spoke heads may sometimes have considerable seam lines that can make an impression or “cut line” in the hubshell hole chamfer. Please inspect and selectively sort out these spokes to minimize this possibility. Spoke nipples on radial spokes may have a tendency to unthread themselves if a spoke preparation compound is not used on spoke

threads. Radial laced wheels are also more sensitive to over- or under-tensioning, thus proper wheel building practices must be followed. Please follow the spoke manufacturer's recommended tension specifications when building wheels. Inspect hubs and check spoke tension at regular intervals. Front R45 hubs may utilize radial lacing, as well as the rear non-drive side of R45 hubs. R45 Disc hubs must utilize 2-or-more cross.

## **POST WHEEL BUILD BEARING PRELOAD ADJUSTMENT**

Your hub bearing preload is set at the factory anticipating spoke tension and skewer compression. However, because of variations in wheel building practices, a minor bearing adjustment may be required upon completion of the wheel build.

## **BREAK-IN**

Once your new hub is placed in service, some settling may occur. Check adjustment by clamping wheel into frame with a quick-release skewer or thru axle. Ride for 5-10 minutes, check for bearing play or binding, and readjust if necessary. Recheck after the first 1-5 hours of riding. Check cog lock ring on rear hubs after the first 20 hours of use, and tighten if necessary. Continue monitoring for the first 60 hours of use. See "Bearing preload adjustment" for details.

During the first 60 hours of use, above average amounts of drag may be noticed. This is normal as the seals break in, and will soon diminish. If this causes chain sag in the rear while back-pedaling, try increasing the B-tension (cage tension) on the rear derailleur.

## **MAINTENANCE**

### **SERVICE SCHEDULE**

Chris King R45 and R45 Disc hubs are designed to provide long life and high performance. Beyond an occasional bearing preload adjustment, the only maintenance necessary is cleaning and lubricating the RingDrive, driveshell and bearings. Riding conditions will determine how often to maintain your hubs. As a beginning guideline, your hubs should be maintained after every 6-12 months of consistent use in normal and dry conditions and every 3 months in wet or muddy conditions.

Normal preventative maintenance of the RingDrive is simple and can be performed using basic tools. In many cases, a cleaning and reapplication of lubricant is all that may be necessary. If the hubs are running smoothly and are free of contamination, refer to hub owner manual.

Periodically (every one to two years), or if foreign debris is detectable in the grease and/or the grease looks hard or dry, a complete servicing (removal and cleaning) of the RingDrive, driveshell and bearings should be performed. Complete service requires the use of our R45 and R45 Disc Hub Service Tool. Go to "Complete service".

The R45 and R45 Disc Hub Service Tool Kit, and replacement hub parts can be purchased through any authorized Chris King dealer or directly from Chris King Precision Components.

Chris King Precision Components provides overhaul services at reasonable rates. Contact the Customer Service hotline at 800-523-6008 for details.

### **WET CONDITIONS**

Riding in wet conditions necessitates more frequent service. Often this is as simple as removing the axle and driveshell from the hub, removing any moisture from inside the hub shell, and applying more lube to the RingDrive assembly. This should not replace periodic complete disassembly and maintenance, especially in extreme or prolonged wet conditions. Since it is nearly impossible to seal a hub from water and still have it spin freely, we have designed our hubs to be able to operate normally with some water intrusion. Although the



bearings are stainless steel and will resist water induced corrosion, the lubricant will eventually deteriorate, leading to premature wear and possible failure. High-pressure spray washing, transporting or riding the bicycle in the rain, or submersion in water while riding can all lead to lubricant contamination by water. Be aware of these situations and service more frequently when they occur.

## **COLD CONDITIONS**

If cold weather riding is anticipated, we recommend servicing your rear hub to ensure that no water is present in the drive components. At temperatures below freezing, water contamination inside the hub can freeze and thus impede hub engagement mechanisms.

## **LUBRICATION**

### **R45 RINGDRIVE™**

We recommend using a quality 10w synthetic oil (such as Mobil 1® 10w-30 or equivalent) on the RingDrive assembly and helical splines on the driveshell. Oil provides optimal low drag, low viscosity lubrication for road riding applications. RingDrive lube is also acceptable. Do not substitute other brands of grease as they may be too thick or sticky for the helix of the RingDrive and cause hub engagement problems.

### **R45 stainless steel bearings**

For R45 bearings with stainless steel balls, apply a bead (approximately 1/4 to 1/3 of the circumference) of RingDrive Lube around the top of the hub bearings. Rotate the inner race to work the lube throughout the ball area.

### **R45 ceramic bearings**

For R45 bearings with ceramic balls, apply enough RingDrive Lube to lightly coat the balls inside the bearing, using approximately a pea-sized amount of lube. This can be accomplished by applying a light bead of lube 1/8 to 1/4 of the way around the bearing. Rotate the inner race to work the lube throughout the ball area. In wet and/or muddy conditions, apply more lube to the bearings to help seal the bearings from contaminants.

## **Solvents**

Use of light duty mineral spirits-based solvents or cleaners is acceptable (i.e. WD-40™). Use of caustic, acidic, or citrus cleaners may result in damage to the anodized coating.

## SERVICE OF THE BEARINGS

Chris King sealed bearings have removable snap rings that hold the rubber seals in place.

1. Carefully, using a very small screwdriver, pick, or penknife, remove the snap ring by inserting tool into split of snap ring. Gently work one end of the snap ring toward bearing center until it is out of its groove. Follow the ring around with the tool until the snap ring is completely dislodged.
2. Lift and remove exposed rubber seal to access the interior of the bearing.
3. Thoroughly flush the bearing with a light solvent-based spray lubricant (e.g., WD-40™).
4. Scrub bearing surface with toothbrush to remove hardened grease and contaminants.
5. Flush bearing again with a light solvent-based spray lubricant.
6. Use compressed air to blow all spray lubricant, grease and contaminants out of the bearings and hubshell. If compressed air is not available, use a clean, lint-free towel to thoroughly wipe out interior of hubshell and bearing surfaces. Bearings and hubshell must be completely dry before adding new lubrication.

Some solvents, synthetic lubricants, and greases with high-pressure additives may attack and damage seals and other nonmetallic materials. Minimize exposure to these substances and thoroughly dry hub after cleaning.

7. Wipe dirt and other contaminants from the seals and snap rings. Avoid cleaning the seals with heavy-duty solvent, which could cause deterioration.
8. Tech Tip: low drag bearing seals in the R45 hubset may dimple or slightly deform when removing bearing snapping and seal from bearing. Flatten any deformities with fingernail before reinstalling onto bearing surface. Replacement seals are available if seals are damaged beyond repair.
9. Lay a bead of our RingDrive II lube (see “Lubrication”), filling the gap between the inner and outer races halfway around bearing. Do not overfill bearing with lube, as this may cause excess drag. Rotate the inner race to work grease throughout the ball area.
10. Replace rubber seal between inner and outer bearing race.
11. Insert one edge of snap ring into groove of outer bearing race. Press along entire groove until snap ring is fully seated; a very small gap should be visible between both ends of the snap ring.
12. Turn inner race of bearing by hand to test for binding. If bearings have excessive drag, try reinstalling seals and snap rings. Bearing drag is often a result of improperly seated seals and/or snap rings.

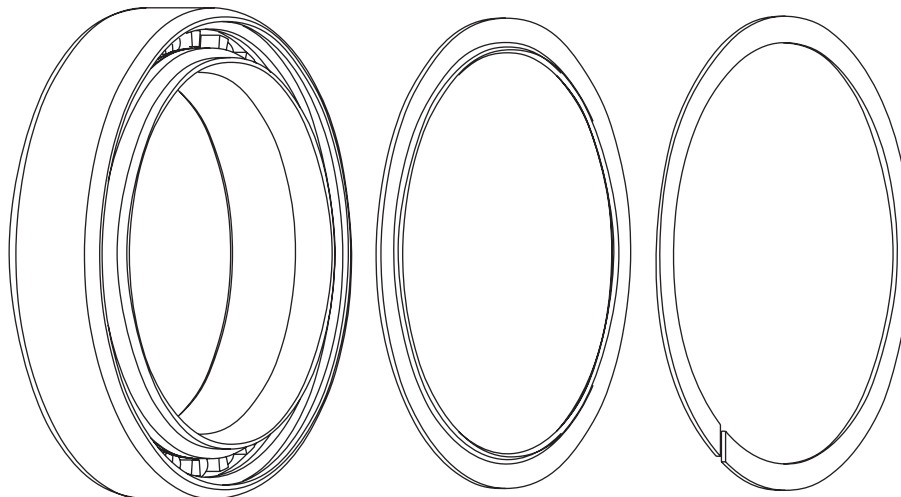

Bearing Assembly

Rubber Seal

Snap Ring

## COMPLETE SERVICE - USAGE OF THE R45 AND R45 DISC HUB SERVICE TOOL

Periodically (every one to two years), or if foreign debris is detectable in the grease and/or the grease looks hard or dry, a complete servicing (removal and cleaning) of the RingDrive, driveshell and bearings should be performed. The R45 and R45 Disc Hub Service Tool allows for all small parts to be pressed out of the hub to be cleaned, inspected, replaced if necessary, and pressed back into the hubshell/driveshell.

**It is important to note that the R45 and R45 Disc Hub Service Tool can only be used on R45 and R45 Disc hubs, and cannot service other Chris King hubs without significantly risking damage to both the tool and hubs. Similarly, the standard Chris King Hub Service Tool (non-R45 compatible version) cannot service R45 hubs without significantly risking damage to both the tool and hubs.**

This tool set is designed only for working on Chris King R45 and R45 Disc hubs. It is not intended to be used with any other parts or on any other hubs. Use other than that for which it is intended may cause damage to the tool, other products, and/or bodily harm.

### INTRODUCTION TO THE R45 AND R45 DISC HUB SERVICE TOOL

The tool is made up of 6 parts

1. T-handle. This is the main part of the pressing device. It is a long shaft with threads on one end, and a bulbous end with a handlebar through it. It has a steel strike piece (1A) in the top of the bulbous end that may be struck with a hammer or mallet. Permanently mounted to the T-handle is the thrust collar (1B), which should be able to spin freely.
2. Driveshell bushing. This is a tube shaped part with one end bigger than the other. It is used when removing and installing the inboard driveshell bearing into the drive shell.
3. Cone washer. This part is a steel washer with one side shaped like a cone. It goes on the small end of the extension shaft before it is screwed into the T-handle. Its function is to make split rings expand (explained in next section).
4. Split rings. These are doughnut shaped with an O-ring around the outside. They have been precisely cut in half to allow them to be expanded to a bigger diameter. These are the pieces that get behind the bearings to force them out by their outer races. The large split ring is for the RingDrive and large hubshell bearing in the rear hub. The small split ring is for all the small bearings in both front and rear hubs.
5. Extension shaft. Once again a threaded shaft but much shorter. With a knurled section on one end and small threads on the other, it screws into the end of the T-handle. A 4 mm hex key can be inserted into the knurled end to gain leverage when needed.
6. Knurled ring. This is the large round piece with a threaded hole. It can be threaded on to either the extension shaft or the T-handle. It is used to pull bearings into their respective bores upon assembly or to capture parts as they are being tapped out.

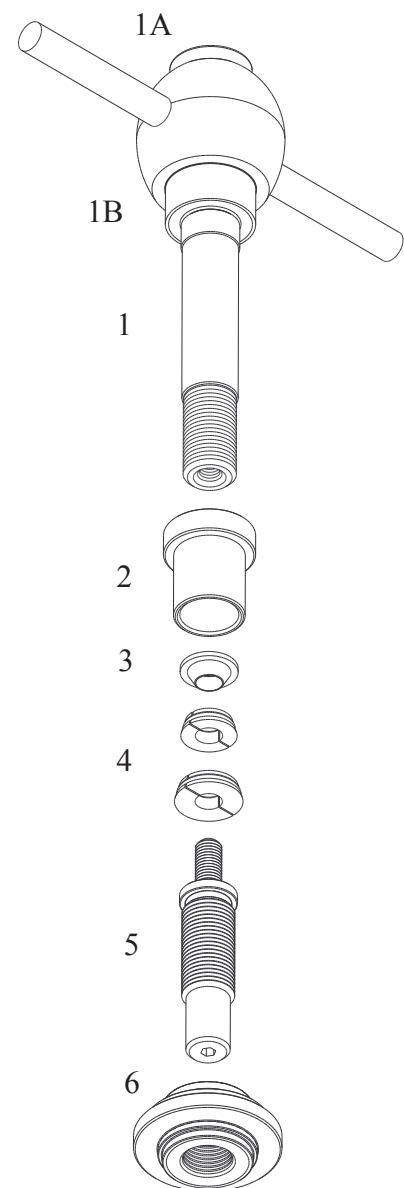

## FUNCTION OF THE EXPANDING SPLIT RINGS

1. Slide the large split ring onto the small end of the extension shaft with laser marked side facing towards knurled end of extension shaft.
2. Follow it by the cone washer, pointed end first, onto the shaft next to the split ring.
3. Take this complete assembly and thread it into the hole in the threaded end of the T-handle.
4. As you screw it together, you will force the cone washer into the split ring. The split ring will begin to expand; continue screwing until the cone has disappeared completely into the split ring. With the cone washer clamping the split ring, fully expanded, against the flange of the extension shaft the tool is ready to drive a bearing. When driving bearings, the split ring should only be used in this fully expanded and clamped position.
5. Release by unscrewing the extension shaft from the T-handle. A hole is provided in the end of the extension shaft for a 4 mm (5/32") hex key in the event it has become too tight to turn with fingers.



## FRONT HUB - COMPLETE SERVICE

Front hub bearing removal is only necessary when a bearing is damaged and must be replaced. If the bearings are contaminated but not damaged, follow the directions in the hub owners manual.

### FRONT HUB COMPLETE DISASSEMBLY

#### R45 AND R45 DISC TOOL SETUP FOR FRONT HUB BEARING DISASSEMBLY

Slide small split ring onto extension shaft with laser marked side facing towards knurled end of extension shaft. Slide cone onto extension shaft with narrow end facing split ring. Thread extension shaft onto T-handle until assembly is snug, but split ring is not expanded.

1. Remove axle skewer from hub
2. Secure “L”-shaped 5 mm hex key in vise with shorter end of “L” facing up
3. With adjusting cone facing up, insert hub onto 5 mm hex key so that hub can sit freely on vise.
4. Insert 5 mm hex key into adjusting cone-side of hub
5. Turn hex key counter clockwise to loosen axle end and adjusting cone from main axle assembly. Unscrew until both items are free from main axle.
6. Unscrew axle end from adjusting cone.
7. Slide main axle from hubshell assembly
8. Both front hub bearing assemblies can now be accessed for cleaning and relubrication.



### REMOVAL OF FRONT HUBSHELL BEARINGS

1. Insert T-handle assembly into hubshell.
2. Turn extension shaft clockwise until tight to fully expand split ring behind bearing, ensure split ring is behind the bearing only and fully expanded.
3. Invert T-handle so that hubshell falls onto expanded small split ring.
4. Thread knurled ring clockwise until it sits tightly against bearing with laser side out.
5. Using a hammer, tap strike plate on T-handle to remove bearing and the inner seal behind it.
6. Repeat steps above to remove second bearing from front hubshell.

After removing bearing from hubshell, check to see if bearing can turn freely. If bearing does not spin, lay bearing onto hard flat surface and tap inner race lightly with a wide headed hammer. This will properly align inner bearing race with outer race.



## FRONT HUB BEARING SERVICE

Clean and relubricate the hubshell bearings. Follow bearing service instructions in the bearing service section in this manual.

Replacement bearings and other small parts can be purchased from any authorized Chris King dealer. Small parts can be purchased directly from Chris King Precision Components.

## FRONT HUB BEARING COMPLETE REASSEMBLY

### R45 TOOL SETUP FOR FRONT HUB BEARING REASSEMBLY

1. Slide onto T-handle: bearing with snap ring facing thrust collar, then white inner seal, then hubshell.
2. Thread knurled ring onto T-handle with laser marked side facing T-handle.
3. Hold knurled ring stationary in one hand while turning T-handle clockwise with the other hand until it stops. This will press the front hub bearing into the hubshell.
4. Repeat steps above to install second front hubshell bearing.



## FRONT HUB FINAL REASSEMBLY AND ADJUSTMENT

1. Vise assembly: setup 5 mm hex key in vise
2. Clean threads and O-rings on main axle, axle end and adjusting cone.
3. Apply thin layer of waterproof grease to threads on axle, axle end, and adjusting cone. Apply a drop of light chain lube (Tri-Flow™, etc) to O-rings on axle.
4. Slide main axle into hubshell assembly.
5. Thread adjusting cone onto protruding axle threads until finger tight against bearing
6. Then unthread adjusting cone a fraction of a turn so that axle spins freely, and no play is detected between axle and bearings.
7. Insert hub assembly onto 5 mm hex key in vise so that adjusting cone is facing up
8. Thread axle end into adjusting cone two full turns, making sure that the adjusting cone does not turn in the process.
9. Place hub cone adjusting tool onto adjusting cone.
10. Use hub cone adjusting tool to hold adjusting cone in place while tightening axle end with 5 mm hex key to 110 in lbs. (12.4 Nm).
11. Check for excessive bearing drag or bearing axle play by turning axle with fingers. If excessive drag is detected, go back to step 6 to reset bearing preload.
12. Do not ride hub loose as it will cause permanent hub shell damage.



## REAR HUB - COMPLETE SERVICE

A complete service on the R45 and R45 Disc rear hub should be performed periodically (every one to two years), or if foreign debris is detectable in the grease and/or the grease looks hard or dry. Also use this process to replace any worn or broken parts within the hub assembly. A complete service involves a thorough cleaning, inspection and relubrication of small parts and hub bearings. An R45 and R45 Disc Hub Service Tool is required for this procedure.

### REAR HUB BASIC DISASSEMBLY

1. Remove skewer, cog lock ring and cassette from hub.
2. Loosen 2.5mm hex bolt on adjusting clamp.
3. Unthread adjusting clamp.

Tech Tip: if adjusting clamp is difficult to remove, first insert a 5mm hex key into drive side axle end to keep axle stationary. Then insert a 2.5mm hex key into hole on adjusting clamp adjacent to 2.5mm hex bolt. Use 2.5mm hex key as a lever to unscrew adjusting clamp.

4. Once adjusting clamp is completely unthreaded, pull straight out, which will remove both the adjusting clamp and R45 QR insert simultaneously. IF QR insert is difficult to remove, insert long 5mm hex through drive side axle and tap with mallet.
5. Remove axle from the main hub assembly by pulling it from drive side of hub. The outboard driveshell bearing may or may not remain on the axle as it is pushed out of the hubshell assembly.
6. Remove driveshell by holding hubshell or wheel in one hand and with other hand pull driveshell straight out of hubshell assembly.

### REAR HUB SMALL HUBSHELL BEARING REMOVAL

#### R45 TOOL SETUP FOR REAR SMALL HUBSHELL BEARING REMOVAL

Slide small split ring onto extension shaft with laser marked side facing towards knurled end of extension shaft. Slide cone onto extension shaft with narrow end facing split ring. Thread extension shaft onto T-handle until assembly is snug, but split ring is not expanded.

1. Insert T-handle assembly into driveside of rear hubshell.
2. Turn extension shaft clockwise until tight to fully expand split ring behind small hubshell bearing
3. Turn extension shaft clockwise until tight to fully expand split ring behind bearing, ensure split ring is behind the bearing only and fully expanded.
4. Invert T-handle so that hubshell falls onto expanded small split ring.
5. Turn knurled ring clockwise until it sits tightly against small hubshell bearing with laser side out.
6. Using a hammer, tap strike plate on T-handle to remove small hubshell bearing and the inner seal behind it.



## REAR HUB LARGE HUBSHELL BEARING AND RINGDRIVE DISASSEMBLY

### R45 TOOL SETUP FOR REAR LARGE HUBSHELL BEARING AND RINGDRIVE DISASSEMBLY

Slide drive shell bushing onto T-handle with wide side facing T-handle. Slide large split ring onto threaded portion of extension shaft with laser side facing knurled end of extension shaft. Then slide cone onto extension shaft with narrow end facing split ring.



1. Thread extension shaft onto T-handle until assembly is snug, but split ring is not expanded.
2. Insert T-handle assembly into non-driveside of rear hubshell.
3. Locate split ring behind spring retainer, ensure that the split ring expands behind the spring retainer.
4. Tighten knurled ring until it sits tightly against large hubshell bearing with laser side out.
5. Using a mallet or hammer, tap strike plate on T-handle to remove large hubshell bearing, inner seal, driven ring, drive ring, spring and spring retainer.

**TECH NOTE: Large hubshell bearing can only be removed along with the entire RingDrive assembly. An attempt to only remove the large hubshell bearing will likely result in the damage to large hubshell bearing and hub service tool.**

## REAR HUB DRIVESHELL DISASSEMBLY

### R45 TOOL SETUP FOR DRIVESHELL DISASSEMBLY

Slide drive shell bushing onto T-handle with wide side facing thrust collar. Slide small split ring onto threaded portion of extension shaft with laser side facing knurled end of extension shaft. Then slide cone onto extension shaft with conical side facing split ring. Thread extension shaft onto T-handle until assembly is snug, but split ring is not expanded.



1. If outboard driveshell bearing remained inside driveshell when axle was removed from driveshell, proceed to step 2. If outboard driveshell bearing was removed along with axle when axle was removed from driveshell, simply remove O-ring and driveshell spring from driveshell manually.
2. Insert the T-handle into the narrower, non-driveside end of driveshell.
3. Expand split ring behind inboard driveshell bearing by threaded extension shaft clockwise.
4. Move driveshell so it sits against knurled ring.
5. Turn extension shaft clockwise until tight to fully expand split ring behind inboard driveshell bearing.
6. Thread knurled ring, laser side facing T-handle. Hold knurled ring stationary in one hand, while turning T-handle clockwise with the other hand. This will remove all remaining contents of driveshell, including inboard driveshell bearing and white bearing seal.



## REAR HUB COMPLETE CLEANING

CHRIS KING SEALED BEARINGS HAVE REMOVABLE SNAP RINGS THAT HOLD THE RUBBER SEALS IN PLACE.

1. Carefully, using a very small screwdriver, pick, or penknife, remove the snap ring by inserting tool into split of snap ring. Gently work one end of the snap ring toward bearing center until it is out of its groove. Follow the ring around with the tool until the snap ring is completely dislodged.
2. Lift and remove exposed rubber seal to access the interior of the bearing.
3. Thoroughly flush all small parts and bearings with a light solvent-based spray lubricant (e.g., WD-40™).

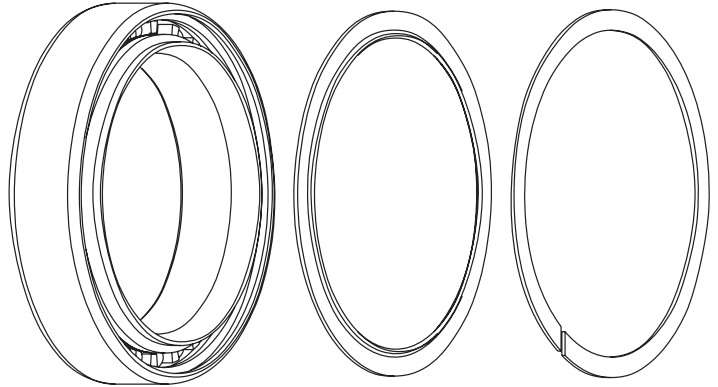

Bearing  
Assembly

Rubber Seal

Snap Ring

Some solvents, synthetic lubricants, and greases with high-pressure additives may attack and damage seals and other nonmetallic materials. Minimize exposure to these substances and thoroughly dry hub after cleaning.

4. Using a toothbrush, scrub bearing surfaces, splines and teeth on drive ring and driven ring, and helical splines on driveshell with toothbrush to remove hardened grease and contaminants.
5. Scrub out interior of hubshell and driveshell.
6. Wipe dirt and other contaminants from the seals and snap rings. Avoid cleaning the seals with heavy-duty solvent, which could cause deterioration.
7. Flush bearings and RingDrive assembly again with a light solvent-based spray lubricant to flush out any remaining contaminants.
8. Use compressed air to blow all spray lubricant, old grease and contaminants from all parts. If compressed air is not available, use a clean, lint-free towel to thoroughly dry all parts. All parts must be completely dry and free of solvents before adding new lubrication and reassembly.

## REAR HUB BEARING LUBRICATION

1. For R45 bearings with stainless steel balls, apply a bead (approximately 1/4 to 1/3 of the circumference) of RingDrive Lube around the top of the hub bearings. Rotate the inner race to work the lube throughout the ball area. For R45 bearings with ceramic balls, apply enough RingDrive Lube to lightly coat the balls inside the bearing, using approximately a pea-sized amount of lube. This can be accomplished by applying a light bead of lube 1/8 to 1/4 of the way around the bearing. Rotate the inner race to work the lube throughout the ball area. In wet and/or muddy conditions, apply more lube to the bearings to help seal the bearings from contaminants.
2. Replace rubber seal between inner and outer bearing race. When reusing seals ensure to install in previous orientation.
3. Insert one edge of snap ring into groove of outer bearing race. Press along entire groove until snap ring is fully seated; a very small gap should be visible between both ends of the snap ring.
4. Turn inner race of bearing by hand to test for binding. If bearings have excessive drag, try reinstalling seals and snap rings. Bearing drag is often a result of improperly seated seals and/or snap rings.

## REAR HUB LARGE HUBSHELL BEARING AND RINGDRIVE REASSEMBLY

### R45 TOOL SETUP FOR REAR LARGE HUBSHELL BEARING AND RINGDRIVE REASSEMBLY

SLIDE DRIVESHELL BUSHING ONTO T-HANDLE WITH LARGER SIDE FACING THRUST COLLAR.

1. Be sure that spring retainer O-ring is installed in inner diameter of spring retainer. Apply a drop of light chain lube (Tri-Flow™, etc) to spring retainer O-ring. Insert spring retainer into driveside of hubshell.
2. Insert spring into hubshell.
3. Insert drive ring into hubshell with engagement teeth facing up.
4. Insert driven ring into hubshell with engagement teeth facing down.
5. Line up splines on outside of driven ring with splines on interior of hubshell. Gently press down on driven ring until it is firmly seated inside of hubshell spline interface.
6. Insert white inner seal into hubshell.
7. Invert T-handle and slide T-handle through non-driveside of hubshell assembly so that driveside is facing up.
8. Place bearing onto hubshell assembly with snapping side facing out.
9. Thread knurled ring, laser marked side facing away from T-handle, onto T-handle until flush with bearing.
10. Hold knurled ring in place while turning T-handle clockwise until large hubshell bearing is fully pressed into hubshell.



1. spring retainer



2. spring



3. drive ring



4. driven ring



7. inner seal



11. knurled ring

## REAR HUB SMALL HUBSHELL BEARING REASSEMBLY

### R45 TOOL SETUP FOR REAR SMALL HUBSHELL BEARING REASSEMBLY

1. Slide small hubshell bearing onto T-handle so that snap ring is facing T-handle
2. Slide white inner seal into T-handle
3. Slide hubshell assembly, non-driveside first, onto T-handle
4. Thread knurled ring, laser marked side facing away from T-handle, onto T-handle until it is flush with large hubshell bearing.
5. Hold knurled ring in place while turning T-handle clockwise until small hubshell bearing is fully pressed into hubshell.
6. Apply 2ml of 10w synthetic oil to RingDrive internals with a syringe.



## REAR HUB DRIVESHELL REASSEMBLY

### R45 TOOL SETUP FOR DRIVESHELL REASSEMBLY

SLIDE DRIVESHELL BUSHING ONTO T-HANDLE SO THAT LARGER END OF BUSHING FACES AWAY FROM T-HANDLE.

1. Slide clean, relubricated small inboard driveshell bearing (laser marked "drive shell-B" on bearing) onto T-handle so that ball bearings face T-handle.
2. Slide on white inner seal onto T-handle.
3. Slide driveshell onto T-handle.
4. Thread on knurled ring, laser side facing in, until snug against driveshell.
5. Hold knurled ring in place while turning T-handle clockwise until inboard driveshell bearing is fully pressed into driveshell.
6. Insert driveshell spacer spring into driveshell.
7. Insert driveshell inner O-Ring into driveshell so that it seats cleanly against driveshell spacer spring



## REAR HUB FINAL REASSEMBLY

1. Apply bead of 10w synthetic oil onto helical splines on driveshell.
2. Insert driveshell into the hubshell; turn in a clockwise motion while letting it pull itself in. A distinctive click sound will indicate that the driveshell is firmly seated.
3. Apply a drop of light chain lube (Tri-Flow™, etc) onto both O-rings on axle and O-ring on QR adaptor. Apply a thin layer of grease onto clean threads on adjusting clamp and adjusting clamp 2.5 mm hex screw.
4. Slide cleaned, relubricated outer driveshell bearing (laser marked “drive shell-C” on bearing) onto main axle with snap ring facing out toward driveside.
5. Insert main axle, threaded (non-driveside) end first into driveshell. Continue until axle is through the hub and driveside end is firmly seated in driveshell.
6. Thread adjusting clamp onto the protruding threads on the non-driveside of axle.
7. Insert R45 QR insert into non-driveside axle end and apply Tri-Flow™ to the o-ring.
8. Snug adjusting clamp up to bearing.

## REAR HUB ADJUSTMENT

THE R45 REAR HUB FEATURES AN ADJUSTING CLAMP AND BEARING SPACER SPRING THAT MAINTAIN PROPER BEARING PRELOAD AND SEATING.

1. Secure “L”-shaped 5 mm hex key in vise with shorter end of “L” facing up
2. With non-driveside facing up, insert hub onto 5 mm hex key so that hub can sit freely on vise. If vise is not available, place the hub or wheel onto a flat, firm surface with the non-driveside facing up.
3. Push downward on the hubshell. This compresses the bearing spacer spring in the drive shell and ensures proper bearing seating. See photos below.
4. While maintaining firm downward pressure on the hubshell, tighten the adjusting clamp onto axle until it stops against bearing. Do not overtighten.
5. Once adjusting clamp is in position, tighten adjusting clamp hex bolt to 10 inch-pounds (1.1 Nm) using a 2.5mm hex key.
6. Double check adjustment by attaching wheel to bicycle frame. Check for bearing play or binding, and readjust adjusting clamp if needed. Further adjustment can be completed with the wheel installed in the bicycle.

Note: Correct adjustment of the rear hub is necessary for proper engagement of the RingDrive. If the hub is run loose, the RingDrive may not engage properly and could lead to permanent damage of the internal parts.

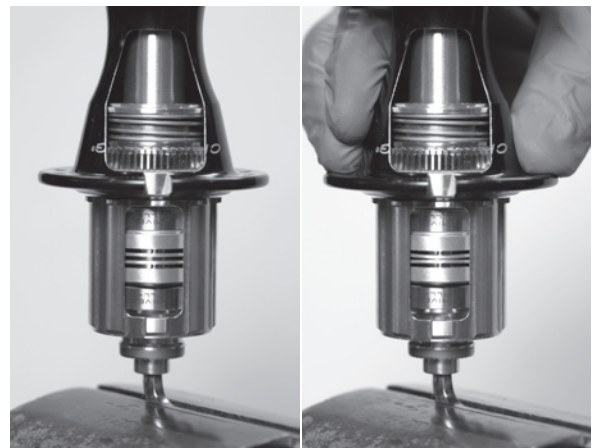

Note bearing spacer spring before being compressed (left), and while under compression (right). Proper bearing preload can be set only while spacer spring is under compression.

## **Additional support**

Check our website often for updated technical information and new revisions of this service manual to help you, our customers, stay on your bike. Visit: [chrisking.com/tech](http://chrisking.com/tech). Additional questions? Please email us at [info@chrisking.com](mailto:info@chrisking.com) or call the customer service hotline at 800-523-6008.

Printed with soy ink. Contains 100% post consumer recycled paper fiber.

Thank you for your purchase!

All Chris King Precision Components products are manufactured in the USA using industry leading environmental and quality control standards.

All trademarks, registered trademarks, and logos are of their respective holders.

©King Cycle Group, 2010. All rights reserved.

**CHRIS KING**<sup>®</sup>  
**PRECISION COMPONENTS**

2801 NW Nela Street, Portland, Oregon 97210  
800.523.6008 | [chrisking.com](http://chrisking.com) | [info@chrisking.com](mailto:info@chrisking.com)