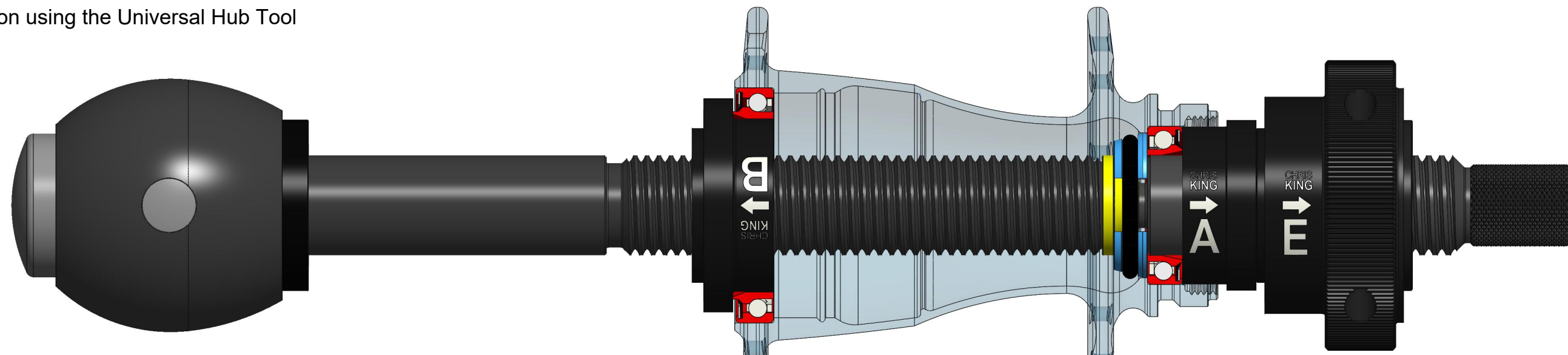

FIGURE B

Boost Centerlock Rear, Superboost Centerlock Rear

Bearing removal and installation using the Universal Hub Tool



Remove non-drive side bearing
B HUB CONE 1 A E
 ← → →

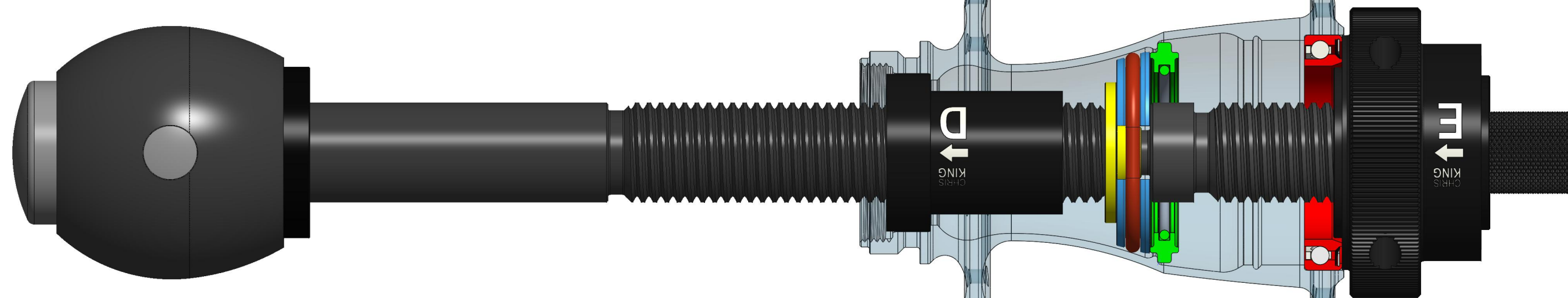

Remove drive side bearing
D HUB LARGE 3 E
 ← ←

Components shown in bright colors for clarity- actual parts are matte finish steel and anodized aluminum

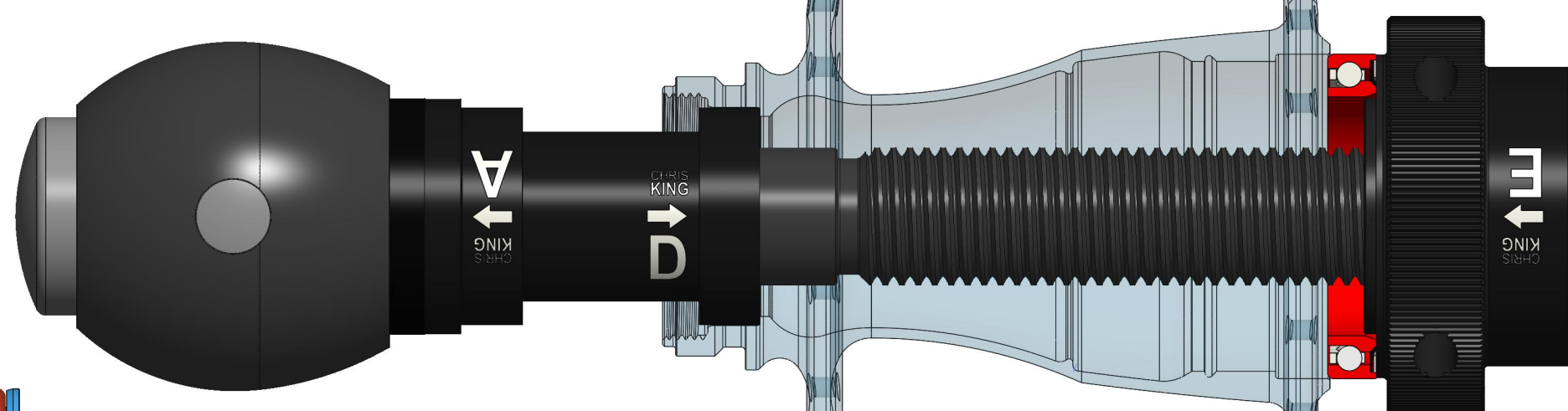
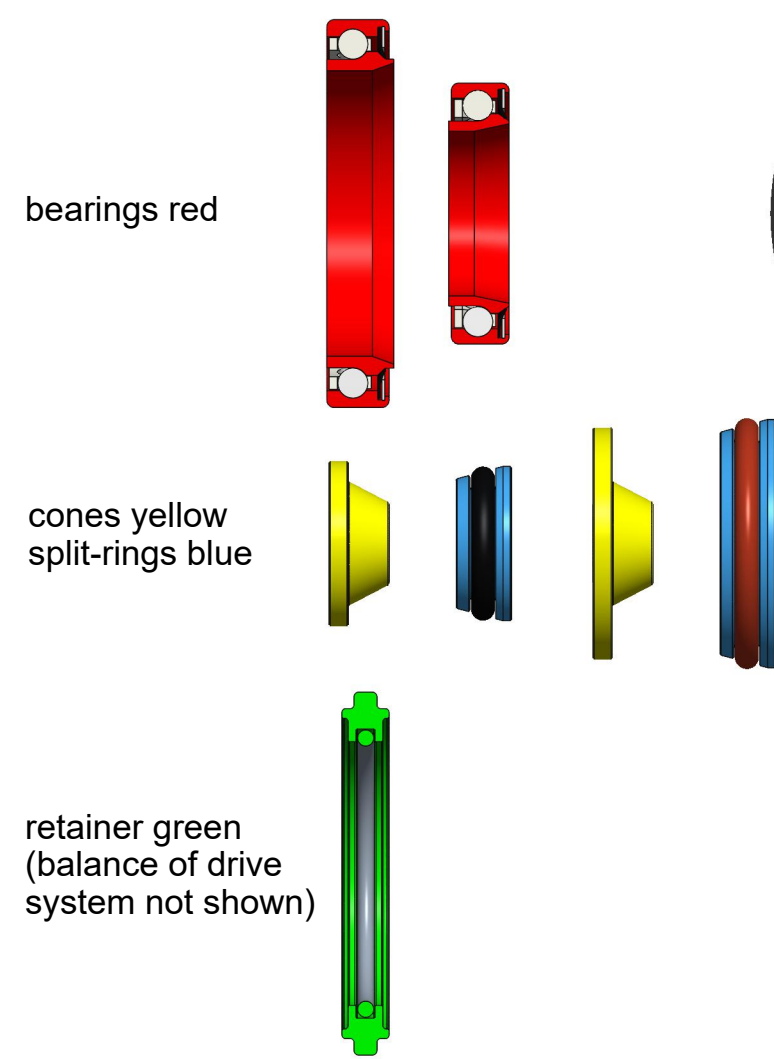

Install drive side bearing
A D HUB BRG E
 ← → ←

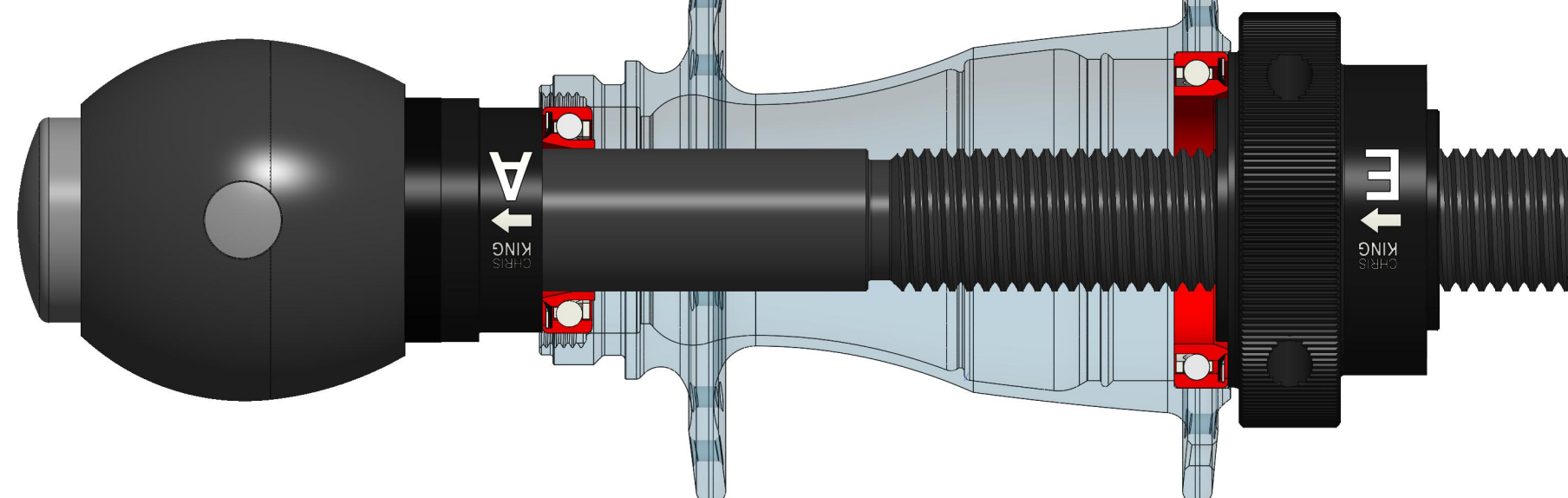

Install non-drive side bearing
A BRG HUB E
 ← ←