

SOLAREPIC

SOLAREPIC

Shenzhen YiCheng Technology Co., Ltd

Tel: +86-755-89373005 /89330785

E-mail: support@solarepic.com

Website: <http://www.solarepic.com/>



1000W Smart Grid Tie Inverter

User Manual

Model: YC-A101 YC-A102

YC-B101 YC-B102

Thanks for choosing SolarEpic Micro Grid Tie Inverter.

Read the following instruction carefully before installation and operating, install and operate as specified by this user manual strictly to ensure your safe and benefit.

Catalogue

Smart Microinverter Introduction.....	2
Important Safety Information.....	3-4
Technical Parameters.....	5
Installation.....	6
LED Indicators.....	7
General troubleshooting.....	8
Stack Wiring Diagram.....	9-10
Warranty.....	11
Explore Applications Diagram.....	12



Explore Applications Diagram

1. Work with solar panel as specified in parameter table

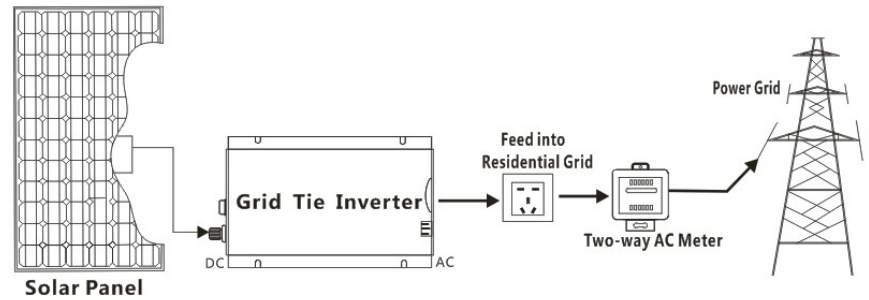

Smart Microinverter Introduction

Smart grid tie inverter is a compact unit, which directly converts direct current into alternating current for powering appliances and/or office equipments and connecting to utility grid. The AC output from Smart Microinverter is synchronized and in-phase with the utility grid. It is a key device of power generation systems such as PV power generation system. Smart Microinverter specially optimized design to work with modularization of DC power supplies which includes the mainstream solar modules, 18V (36 cells), 24V (60 cells) and 36V (72 cells) monocrystal and/or Polycrystalline solar panels. Smart Microinverters are stabilization, reliable and high conversion efficiency items. It is the best choice for PV power generation systems.

Smart Microinverter can be easily placed and attached to the rack underneath of PV module. No need spaces for independent installation and low voltage DC wire connects from the PV module to Smart Microinverter can eliminate the risk of high DC voltage. Distributed modularization design philosophy for Smart Microinverter insures the productiveness of the whole system and will not affect by a single point of failure. Each Smart Microinverter is individually connected to each PV module in the array. This unique configuration means that an individual Maximum Peak Power Point Tracker (MPPT) controls each PV modules and insures that the maximum power available from each PV module is exported to the utility grid regardless of the performance of the other PV modules in the array which may be affected by shading, soiling, orientation or mismatch, etc. Smart Microinverter insures top performance for maximizing energy production from the whole PV system and gets return on investment in less time.

Advantages of Smart Microinverter

1. Unique circuit design, choice of import industrial electronic components, higher efficiency, more stable performance.
2. Creative MPPT technology, efficiency more than 99%, faster and more sensitive reaction, more reliable.
3. Parallel type design for DC input and modularization design for inverter, small volume, distributed installation, easy for system configuration, flexible for combination, strong expansibility of system.
4. Adopting high-frequency isolation transformer type, high efficiency, and high security.
5. Perfect electrical protection function.
6. Aluminum alloy housing, not rust, heat-resisting and cold-resistant as well as anti-corrosion.
7. Getting electronic circuit design, appearance design and other core technology patents.

Important Safety Information

Read this First

This manual contains important instructions for use during installation and maintenance of the Smart Microinverter. To reduce the risk of electrical shock, and to ensure the safe installation and operation of the Smart Microinverter, the following safety symbols appear throughout this document to indicate dangerous conditions and important safety instructions.



DANGER! This indicates a hazardous situation, which if not avoided, will result in death or serious injury.



WARNING! This indicates a situation where failure to follow instructions may be a safety hazard or cause equipment malfunction. Use extreme caution and follow instructions carefully.



NOTE: This indicates information particularly important for optimal system operation.

Follow instruction closely.

Warranty

Warranty Conditions

Warranty Period: 1 year limited warranty period.

Warranty Evidence: The B/L, Tracking no, and a completed warranty card.

We grant an implied warranty of 1 year to the inverter from date of purchase for repair or replace the Defective Product. Furthermore, we provides an additional limited warranty for 1 years for repair or replace the Defective Product free of charge but non-free of freight charge. If your device has a defect or malfunction during the warranty period, please also contact our customer service staff or your retailer or installer.

Warranty claims are excluded for:

- Alterations or repairs to the unit without prior authorization
- Improper use or operation of device
- Improper and non-standard installation
- operating the equipment with defective safety devices
- Impact of foreign objects and force majeure (lightning, surge, storm, fire)
- Inadequate or nonexistent ventilation of the device
- disregarding of safety regulations
- shipping damage
- The Product has been improperly stored or was damaged while in ossession of the Dealer or end user;



WARNING! Only qualified electrical professionals can do the trouble shooting of the Smart Microinverter system.



WARNING! Do not disconnect the Microinverter from its PV module when the inverter is still operating. Disconnect the inverter from the PV module during running may damage the Microinverter and bring electrical hazard to the person nearby.



WARNING! Disconnect the AC grid first before disconnecting the inverter from the PV module.



WARNING: Do not attempt to repair the Smart Microinverter. This may bring electrical hazard to the person and it will also void the Microinverter warranty. If troubleshooting methods fail, please contact customer support to return the Microinverter and initiate for replacement process.

Safety Instruction

- Do not use Smart Microinverter in a manner not specified by the manufacturer. Doing so may cause death or injury to persons, or damage to equipment.
- Perform all electrical installations in accordance with all applicable local electrical codes.
- Be aware that only qualified personnel should disassemble and repair the Smart Microinverters and non-qualified personnel should not install and/or repair.
- Do not attempt to repair the Smart Microinverter; it contains no user-serviceable parts. If it fails, contact customer service to claim a return merchandise authorization and start the replacement process. Tampering with or opening the Smart Microinverter will void the warranty.
- If the AC cable connector on the Microinverter is damaged or broken, do not install the unit.
- Before installing or using the Smart Microinverter, read all instructions and cautionary markings in the technical description and on the Smart Microinverter System and the PV equipment.
- Connect the Smart Microinverter to the utility grid only after you have completed all installation procedures and after receiving prior approval from the local electrical utility company.
- Be aware that the body of the Smart Microinverter is the heat sink. Under normal operating conditions, the temperature is 15°C above ambient, but under extreme conditions the Microinverter can reach a temperature of 75°C. To reduce risk of burns, use caution when working with Microinverters.
- Our suggestion is that do NOT disconnect the PV module from the Smart Microinverter without first removing AC power when Smart Microinverter still operation because it may cause of components damaged.
- Keep away from children, no touching, no playing so as not to electric shock when using.
- Please installed in place of low humidity and well-ventilated so as to avoid inverter overheating, as well as clear around the inflammable and explosive materials.

Technical Parameters:

Rated Power	1000W	
Solar Panels	36 cells/18V Vmp: 18-21V; Voc: 20-24V	60 cells/24V Vmp: 26-30V; Voc: 34-38V 72 cells/36V Vmp: 35-39V; Voc: 42-46V
DC Input Range	10.8-30V	20-45V
MPPT Voltage	15-23VDC	25.5-38VDC
DC MAX. Current	80A	50A
AC Output	120VAC(90-140VAC) or 230VAC(190-260VAC)	
Frequency	50Hz/60Hz(Auto control)	
Power Factor	>97.5%	
THD	<5%	
Phase Shift	<2%	
Efficiency	120VAC(90-140VAC)	
Peak Efficiency	82%	87%
Stable Efficiency	79%	85%
Efficiency	230VAC(190-260VAC)	
Peak Efficiency	82%	87%
Stable Efficiency	80%	85%
Protection	Islanding; Short-circuit; Low Voltage; Over Voltage; Over temperature Protection	
Working Temperature	-25°C-80°C	
Working Humidity	0%~90%RH non-condensing	
Waterproof	Indoor design	
Show	Luminous Diode(LED)	
Cooling	Fan	
Stand-by Power	<1W	
EMC	EN61000-6-3:2007 EN61000-6-1:2007	
Grid Disturbance	EN 50178+EN 62109-1+VDE0126-1-12	
Grid Detection	DIN VDE 1026	



Smart Microinverter Stack Wiring Diagram

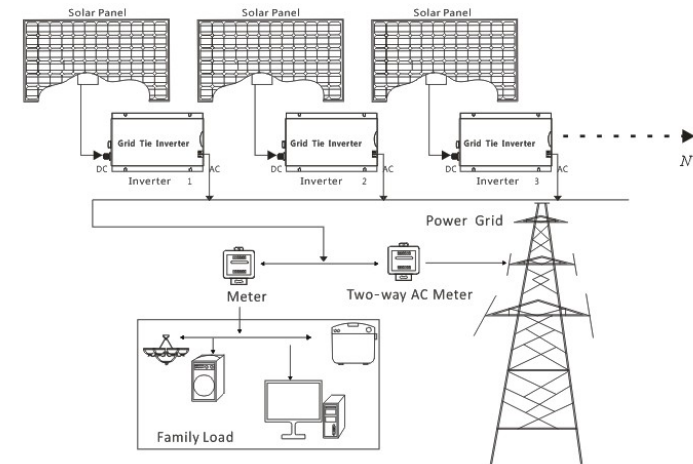
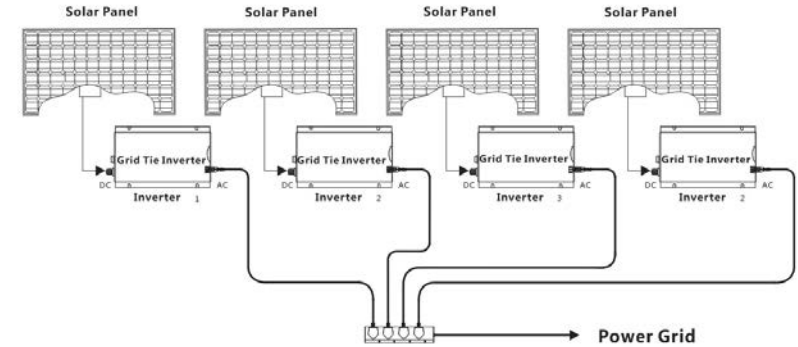

Microinverter or not,

- c) Please visual inspection for the LED operation status, red LED will turn off and green LED will flash or run when inverter connecting with DC power supply which input voltage is fit in with the range as specified and power grid properly. If still no power output when green LED flash or run, probably internal components are damaged, in such case, please turn the defective inverter back for further analyze.

d) Please visual inspection for the LED operation status, red LED still turn on and green LED without any flash or run when inverter connecting with DC power supply which input voltage is fit in with the range as specified and power grid properly, probably internal components are damaged, in such case, please turn the defective inverter back for further analyze.



Smart Microinverter Three Phase output Wiring Diagram

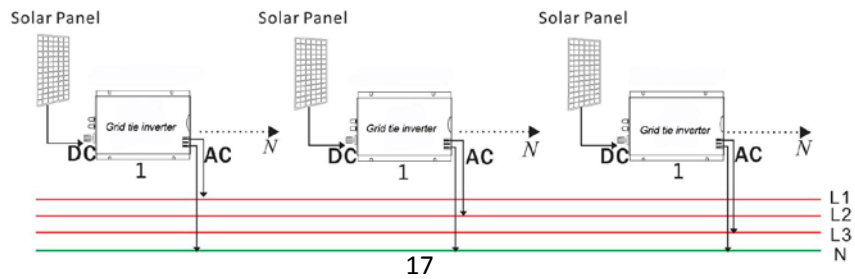

Installation

1. Diagrammatize DC input and AC output terminals,

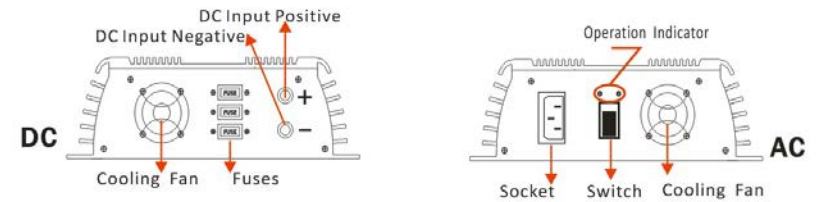

2. Attach the Smart Microinverter to the racking or fix onto the wall,

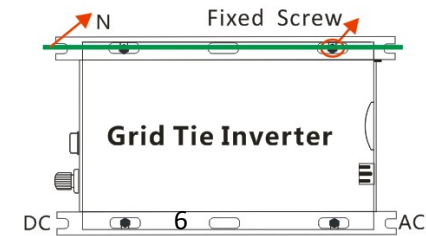

3. Properly connect the positive and negative of solar panel and Smart Microinverter,

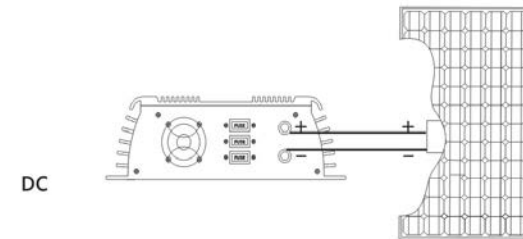

4. AC power cable connects with Smart Microinverter and residential power grid which refers to low voltage civilian single-phase power grid.

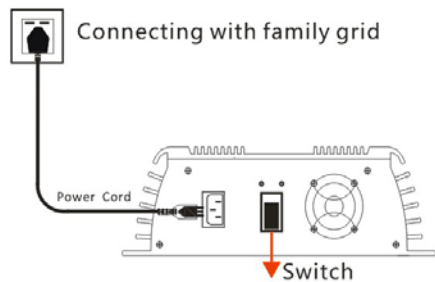

5. Switch on power grid after check for input and output connections are correct and then switch on the Smart Microinverter. The Red/green LED lights up at the same time and then red LED lights off follow on and green LED flash fast, it means that Smart Microinverter is run for MPPT operation. When green LED long light and it is means that maximum power point lock-in, Smart Micro inverter proper functioning and output steady.

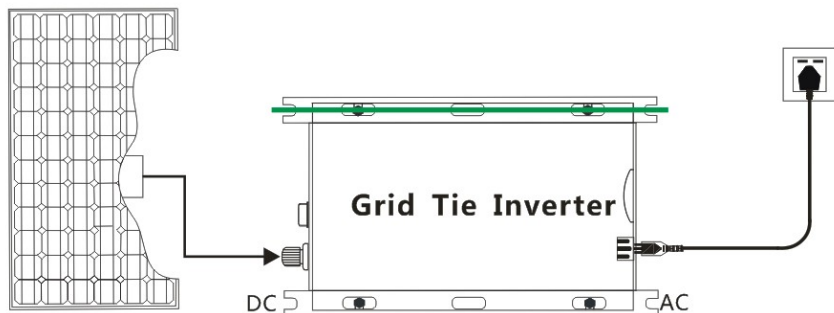

Status Indications of LED

1. Red LED indicator lights up under any conditions include but not limited:

- a) Low-voltage protection (DC input voltage lower than Min. input voltage of inverters),
- b) Over-voltage protection (DC input voltage higher than Max. input voltage of inverters),
- c) Over-temperature protection (inverters will shut down for power output when temperature of body of inverters higher than 65-75°C, and inverter will be automatically restart up when temperature down to 40-50°C.)

- d) Power grid fault protection when 110VAC or 220VAC grid power outage and/or tripped.
- e) Islanding protection: inverter will be automatically shut down for power output when disconnect with power grid.
- f) Short-circuit protection: inverter stops work when output line short-circuits..
- g) Red LED lights on for a while and then green LED lights on in one second when inverter starts to work.

2. Green LED indicator lights up under any conditions include but not limited:

- a) Green LED flash: adjusting for power output, MPPT operating for tracking.
- b) Green LED long light: indicates inverter locking-in Max. output power operation status.
- c) When green LED flash from the bottom up in turns, it is indicates the inverter is locked at maximum power point as well as the output power is steady. The more power output, the faster running of green LED.

3. Please note that above operations only run at grid-connected status.

Troubleshooting a non-operating Smart Microinverter

1. System halted and /or without power output

- a) Check if switch of Smart Microinverter is turn on or not,
- b) Check if the DC connections to Smart Microinverter are correct or not,
- c) Check if any reverse DC connections for positive or negative or not,
- d) Check if DC input voltage is within the range of the Smart Microinverter's or not,
- e) Check if the utility grid voltage and frequency are fit in with the serviceable range of Smart Microinverter or not,
- f) Check if fuses of DC side are fusing or not,
- g) Check if utility grid voltage properly connecting to Smart Microinverters or not,

2. DC power supply is normal but no power output:

- a) Check if utility grid voltage is connecting to Smart Microinverter or not,
- b) Check if utility grid voltage is fit in with the serviceable range of Smart