



Niro[®]2

WiFi Garage Controller and Camera

INSTALLATION GUIDE

TABLE OF CONTENTS

1	WHAT'S IN THE BOX
3	DEVICE INFORMATION
6	MOMENTUM SECURE APP
8	CAMERA INSTALLATION
18	WIRELESS DOOR SENSOR INSTALLATION
20	PAIRING INSTRUCTIONS
23	FEATURES
27	TROUBLE SHOOTING

1

WHAT'S IN THE BOX

WHAT'S IN THE BOX



Wireless Door Sensor

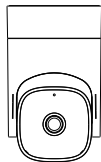

Niro®2



Screws (x2)
Wall Anchors (x2)



USB Cable



Garage Door Wire



Reset Pin



Power Adapter

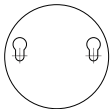

Drill Template



Double-Sided
Sticker



Test Wire

2

DEVICE INFORMATION

DEVICE INFORMATION - Niro[®]2



1. Microphone
2. Status Light Indicator
3. Camera Lens
4. LED Spotlight
5. Micro SD Card Slot/
Reset Pin Hole



6. USB Power Port
7. Garage Wire Terminals
8. Speaker

DEVICE INFORMATION - Wireless Door Sensor

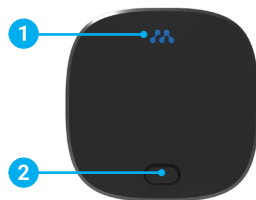

1. LED Indicator Light
2. Sync Button



3. Cover Removal Tab

3

MOMENTUM SECURE APP

MOMENTUM SECURE APP



- Download the **Momentum Secure App** from the Apple App Store or Google Play Store.
- **Create a new account** with your email address or login to your existing account.

4

CAMERA INSTALLATION

CAMERA INSTALLATION – Compatibility Check

IMPORTANT: Before you start, check to make sure your garage opener model is compatible with the Niro®2. See below for compatibility check guide.

- Niro®2 will work with most garage opener models after 1993. Start by doing the following:
 1. For a quick check, use the test wires included. (See next page for how to use test wires).
 2. Niro®2 is not compatible with garage openers with Security +2.0 (yellow button) or MyQ® technology.
 3. Visit momentumcam.com for a list of compatible models.
- If your garage opener is not compatible following the steps above, please contact us at help@momentumcam.com for further assistance.

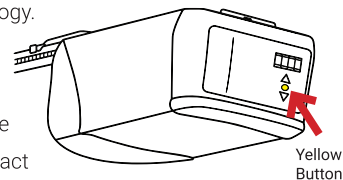

CAMERA INSTALLATION – Compatibility Check

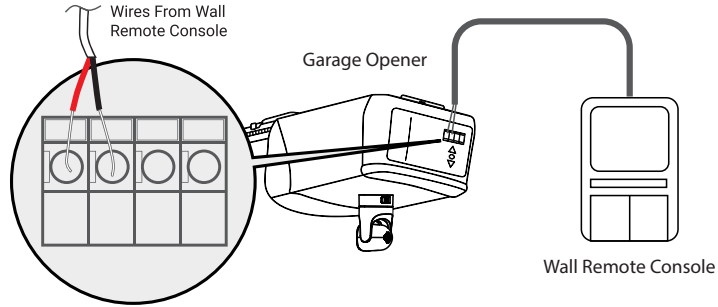

- You can do a quick compatibility check using the test wire provided. First locate the ports with wires from your wall remote console to your garage opener.

CAMERA INSTALLATION – Compatibility Check

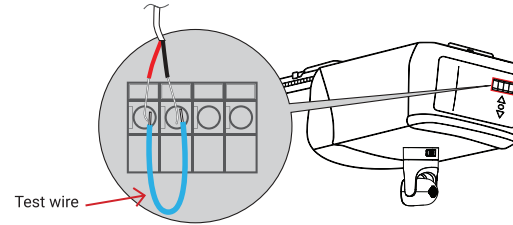

- Insert one end of the test wire in one port and the other end in the other port. If the garage door opens or closes once you place both ends into the ports, then the Niro[®]2 is compatible with your garage opener. If the garage door does not open or close your garage opener may not be compatible. Contact us at help@momentumcam.com for further assistance.

Note: If you're still unsure which terminals to connect the wires to, please refer to your garage opener's instruction manual to verify

CAMERA INSTALLATION – Mounting Camera

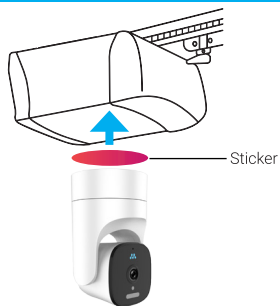

- It is recommended to have the Niro[®]2 attached from the bottom of your garage opener for the best view of your garage.
- To do this, use the double-sided 3M sticker provided and place it on the bottom of your Niro[®]2. Then place the Niro[®]2 with the other sticker side onto the bottom of your garage opener with the “Front” sticker on the device facing the garage door.

Note: Make sure the surface of where you are attaching the Niro[®]2 to the garage opener is cleaned prior to sticking the device on for the best results.

CAMERA INSTALLATION – Wiring to Garage Opener

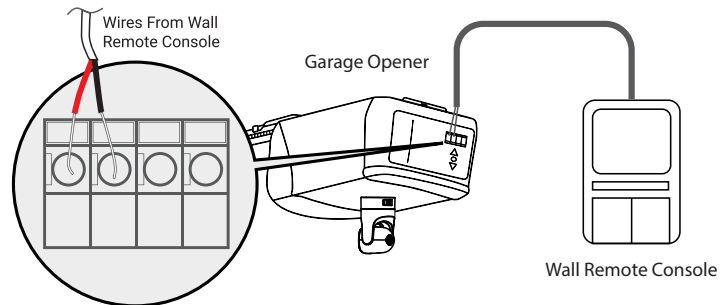

- Unplug your garage opener power.
- Locate the terminals on the back of your garage opener. You can also locate this by following the wires from your wall remote console or button to your garage door opener.

Note: If you're still unsure which terminals to connect the wires to, please refer to your garage opener's instruction manual to verify

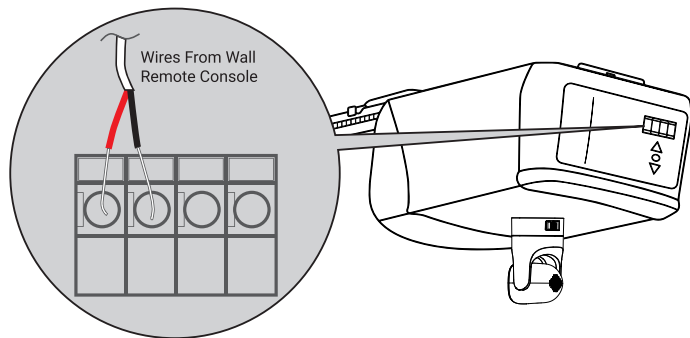

- Connect the garage door wires provided into the same wire ports as your garage wall remote console or button. This may require you to press down on the tabs or loosen screws depending on your garage opener model.

Note: If you're still unsure which terminals to connect the wires to, please refer to your garage opener's instruction manual to verify

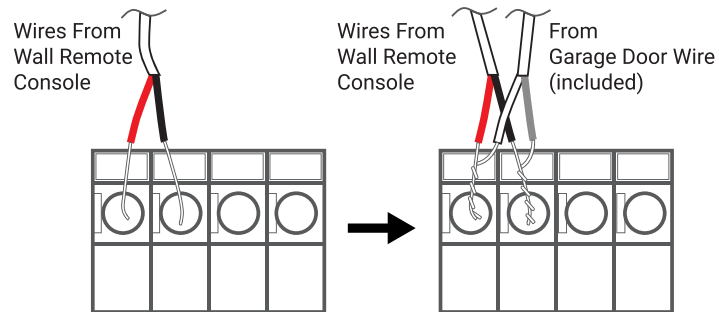

- Twist the two wires together into each terminal for better connection, but make sure the wall console wires go into their original terminals.

Note: If you're still unsure which terminals to connect the wires to, please refer to your garage opener's instruction manual to verify

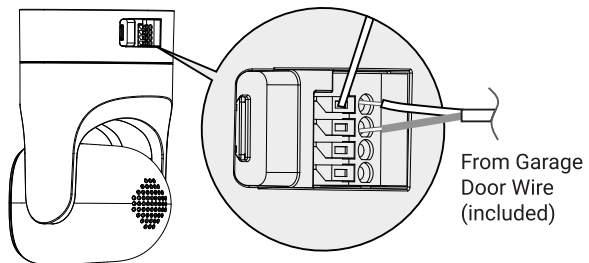

- Insert the other end of the garage door wires into the Door 1 Terminals illustrated above on the back of the Niro®2 device. You may need to use a tool to push down on the buttons to release and insert the wires.
- Once the wires are inserted you may plug back the power for the garage opener.

*Note: Both wires are neutral, so it does not matter which wire goes into which of the two ports. **However, make sure the open wire ends are not touching each other.***

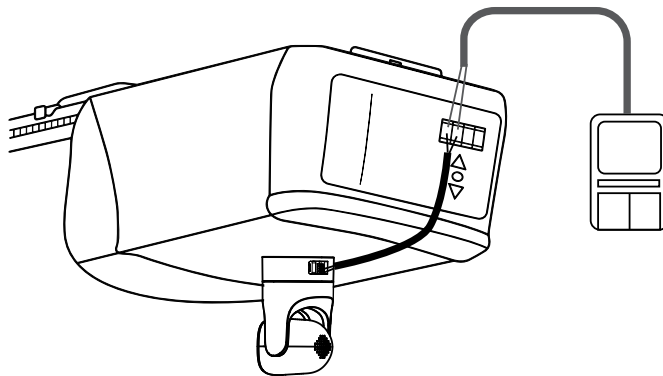

- Congratulations, you have finished installing your Niro®2! See the next page for how to install the Wireless Door Sensor.

5

WIRELESS DOOR SENSOR INSTALLATION

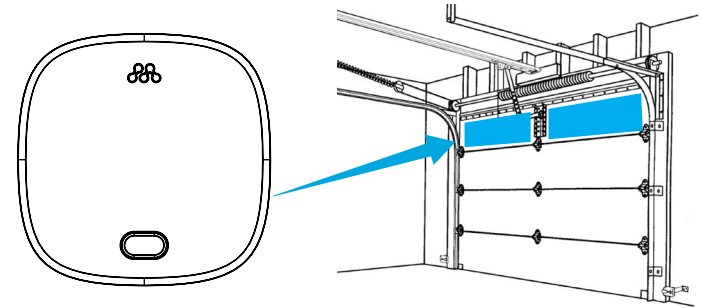

- Next you will have to install the Wireless Door Sensor on your garage door.
- Remove the film from the sticker on the back of the sensor. Place it on the left or right section of your garage door as illustrated above.

6

PAIRING INSTRUCTIONS

PAIRING INSTRUCTIONS

Step 1 – Connect the Niro®2

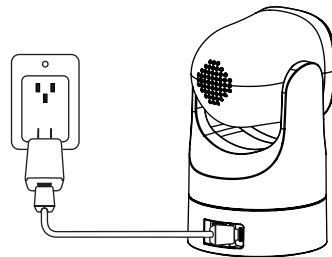

1. **Power the Niro®2** by connecting the power adapter to a nearby outlet.

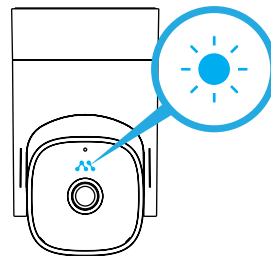

2. Wait for the indicator light to **flash red and blue.**

PAIRING INSTRUCTIONS (Continued)

Step 2 – Connect the Niro®2

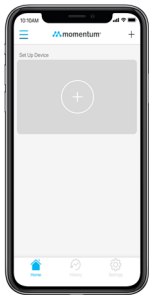

1. Tap the + icon to **add a new device**
2. **Select the Niro®2** camera option.

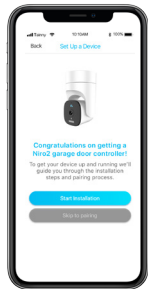

3. Follow the **on-screen app instructions** to complete the pairing process.

7

FEATURES

FEATURES

Dashboard

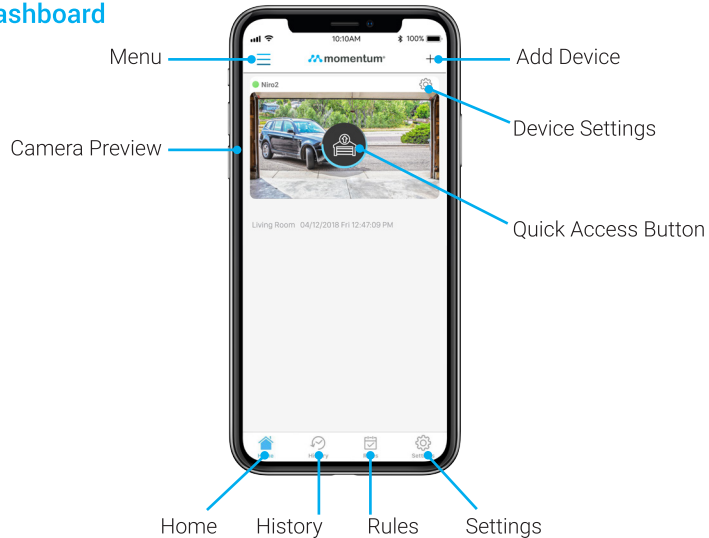

FEATURES (Continued)

Motion Tracking

With auto motion tracking and the pan and tilt feature, the Niro®2 can follow moving objects to keep it in the center screen. You won't have to worry about missing something or someone out of view.

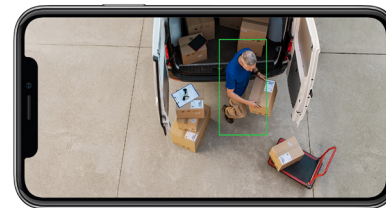

Human Detection

Have the camera only alert you based on human-shaped objects to help avoid false alerts from shadows, lighting, plants, and others.

Garage Door Closure Warning

When the Niro®2 is activated to close, it will send an audible beeping sound and flash the LED to warn others around the door is closing. This is to ensure everyone around is safe and to signal the garage door is moving.



Free Cloud Storage

Every camera comes with FREE 24-hr video history that can be played back from the app. You can even download the recordings directly to your mobile device for permanent safe-keeping.



8 TROUBLE SHOOTING

TROUBLESHOOTING

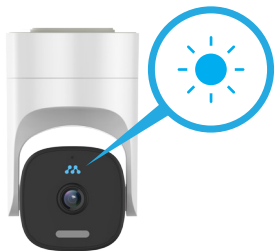

LED Color	Description
Solid Red	Camera is booting
Blinking Red	Disconnected from WiFi
Blinking Red and Blue	Camera is in pairing mode
Solid Blue	Live stream/recording in progress

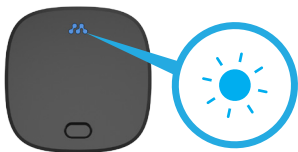

LED Color	Description
Solid Red	Sensor is booting
Double Blinking Red	Low Battery
Blinking Red and Blue	Sensor is in pairing mode
Solid Blue	Sensor is paired

TROUBLESHOOTING (Continued)

Common Issues

If your camera is having app, streaming, or connection issues, try these steps to correct the issue.

Force close the app

If you're experiencing issues with the app, many times it can be resolved by restarting the app. Completely close the app on your mobile device then open the app again.

Power cycle the camera

Unplug the camera, wait 10 seconds, then plug it back in.

Reset the camera

1. To reset the camera, press and hold the reset using the reset pin included on the top of the camera for 10 seconds. During the reset sequence, the LED indicator light on the front of the camera will first display solid red, then blinking blue.
2. Once the LED indicator light is blinking red and blue, you will need to pair the camera again.

Frequently Asked Questions

Why is my Niro®2 Garage Door Camera not pairing?

There could be several reasons. Here are some options for resolution for the problem:

1. You should see the camera's indicator blinking red and blue before pairing. If there is a different color sequence showing, press and hold the reset using the pin included for 10 seconds on the top of the camera to reset it.
2. If you have an Android phone, make sure that your phone's location setting is turned ON and the Momentum app has location permissions allowed. (Momentum does not track location of our users, but this is an Android system requirement for pairing that cannot be bypassed.)
3. Check that you are in an area with a strong Wi-Fi signal. Make sure your mobile device is on the Wi-Fi network you wish your camera to be connected to.
4. Try force closing the app, then open back and try re-pairing.
5. Make sure your mobile device is compatible. (iOS 10.0+ / Android 7.0+)

Why doesn't the app control open/close my garage door?

There could be a few reasons why the app is not opening/closing the garage door.

1. The most common reason is that the garage opener is not compatible with the Niro®2 device. See our compatibility list on our website. If your garage opener uses MyQ™, Security+ 2.0, or has a yellow learn button, the Niro®2 device will NOT be able to control your garage door.
2. Is the Niro®2 device making a clicking noise when you trigger the garage door from the app?

If no, it could be due to a weak network signal or the device itself is defective.

If yes, then it could be the wiring is loose either on the back of the Niro device or on the garage opener terminal connections.

Why is the video stream so slow?

This may be caused by a slow connection from the camera. You can also try improving the video speed by lowering the video resolution from the camera settings.

TROUBLESHOOTING (Continued)

Why can't I find this device on the pairing list?

Make sure that you've downloaded the correct Momentum Secure app from the app store.

Do I need a microSD card to record videos?

A microSD card is not necessary as every camera comes with free cloud storage that allows you to save recorded activity for 24 hours.

How many doors can the Niro®2 Control?

You can control up to 2 garage doors with a single Niro®2 device. You can also pair another wireless door sensor to the second door. (Second door sensor is sold separately)

Why does the stream keep failing to load?

There could be several reasons, but most commonly it may be due to poor internet connection from the mobile device you're using to stream the camera. Make sure you have a strong internet connection while attempting to stream.

After Installing the Niro®2, will my existing wall buttons and remote control still work?

Yes, the Niro®2 will not affect any existing items.

TROUBLESHOOTING (Continued)

Why LED indicator on the wireless door sensor is double blinking red?

It indicates the battery is low and battery replacement is needed.

How to replace the wireless door sensor battery?

1. Press the tabs on both sides of the top cover and lift as illustrated.
2. Replace the CR2450 battery in the battery holder. Once it is secured snap back the top cover to the base cover.

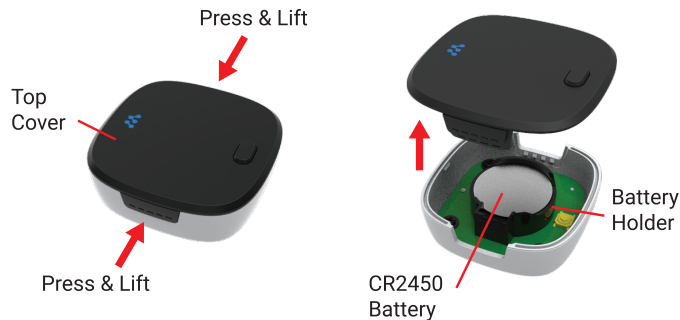

For further assistance, please see our help page at <https://support.momentumcam.com>.

Disclaimers

Mobile device OS compatibility is subject to change as new versions are released. It is recommended to stay up-to-date with the latest OS versions to ensure the app will stay compatible.

App screens and functions may change overtime as we continue to improve our software. Please refer to our website for the latest guides available.

FCC Compliance

This device complies with part 15 of the FCC Rules.

Operation is subject to the following two conditions: (1) this device may not cause harmful interference, and (2) this device must accept any interference received, including interference that may cause undesired operation.

Note: This equipment has been tested and found to comply with the limits for a Class B digital device, pursuant to part 15 of the FCC Rules. These limits are designed to provide reasonable protection against harmful interference in a residential installation. This equipment generates, uses and can radiate radio frequency energy and, if not installed and used in accordance with the instructions, may cause harmful interference to radio communications. However, there is no guarantee that interference will not occur in a particular installation

If this equipment does cause harmful interference to radio or television reception, which can be determined by turning the equipment off and on, the user is encouraged to try to correct the interference by one or more of the following measures:

- Reorient or relocate the receiving antenna.
- Increase the separation between the equipment and receiver.
- Connect the equipment to an outlet on a circuit different from that to which the receiver is connected.
- Consult the dealer or an experienced radio/TV technician for help.

To ensure continued compliance, any changes or modifications not expressly approved by any party. Responsible for compliance could void the user's authority to operate the equipment. (Example - use only shielded interface cables when connecting to computer or peripheral devices.)

This equipment complies with Part 15 of FCC Rules. Operation is subject to the following 2 conditions:

1. This device may not cause harmful interference, and
2. This device must accept any interference received, including interference that may cause undesired operation.

FCC Radiation Exposure Statement:

The equipment complies with FCC Radiation exposure limits set forth for uncontrolled environment. This equipment should be installed and operated with minimum distances of 20cm between the radiator and your body.

ONE YEAR LIMITED WARRANTY

The Company hereby warrants to the original retail purchaser of this product that should this product or any part thereof, under normal use and conditions, be proven defective in material or workmanship within one year parts and 90 days labor from the date of original purchase, such defect(s) will be repaired or replaced with reconditioned product (at the Company's option) for parts and repair labor. This limited Warranty is the purchaser's exclusive remedy for any such defect(s).

To obtain repairs or replacement within the terms of this warranty, please visit www.momentumcam.com or contact us at

1.888.818.0436

Open Mon-Fri 8am-5pm.

Apollo Tech USA Inc.

8608 Utica Ave #220

Rancho Cucamonga, CA 91730

Proof of warranty coverage (i.e. - dated bill of sale) is required.

This Warranty does not apply to any product or part thereof which, in the opinion of the Company, has suffered or been damaged through alteration, improper installation, mishandling, misuse, neglect, accident, or by removal or defacement of the factory bar code label(s). The opinion of the Company with respect to this matter shall be final.

THE EXTENT OF THE COMPANY'S LIABILITY UNDER THIS WARRANTY IS LIMITED TO THE REPAIR OR REPLACEMENT PROVIDED ABOVE AND, IN NO EVENT, SHALL THE COMPANY'S LIABILITY EXCEED THE PURCHASE PRICE PAID BY PURCHASER FOR THE PRODUCT.

THIS WARRANTY IS IN LIEU OF ALL OTHER EXPRESS WARRANTIES OR LIABILITIES. ANY IMPLIED WARRANTIES, INCLUDING ANY IMPLIED WARRANTY OF MERCHANTABILITY, SHALL BE LIMITED TO THE DURATION OF THIS WRITTEN WARRANTY. ANY ACTION FOR BREACH OF ANY WARRANTY HEREUNDER, INCLUDING ANY IMPLIED WARRANTY OF MERCHANTABILITY, MUST BE BROUGHT WITHIN A PERIOD OF 30 MONTHS FROM THE DATE OF ORIGINAL PURCHASE. IN NO CASE SHALL THE COMPANY BE LIABLE FOR ANY CONSEQUENTIAL OR INCIDENTAL DAMAGES FOR BREACH OF THIS OR ANY OTHER WARRANTY EXPRESS OR IMPLIED WHATSOEVER.

No person or representative is authorized to assume for the Company any liability other than expressed herein in connection with the sale of this product. Some jurisdiction do not allow limitations on how long an implied warranty lasts or the exclusion or limitation of incidental or consequential damages so the above limitations or exclusions may not apply to you. This Warranty gives you specific legal rights and you may also have other rights, which vary from jurisdiction to jurisdiction.

Visit us:

www.momentumcam.com

Call us:

1.888.818.0436

Email us:

help@momentumcam.com

Momentum Secure app features:

To help guide you through the features of the Momentum Secure app, please refer to the user guides linked in the app or visit: support.momentumcam.com