

**Other Briggs & Stratton
Commercial Power Repair Manuals:**

- 272147 - Vanguard™ Single Cylinder OHV Air-Cooled Engines
- 272144 - Vanguard™ Twin Cylinder OHV Air-Cooled Engines
- 275429 - Vanguard™ Twin Cylinder OHV Liquid-Cooled Engines
- MS-1055 - Vanguard™ 3-Cylinder OHV Liquid-Cooled Diesel Engines



COMMERCIAL POWER

Briggs & Stratton



COMMERCIAL POWER

Vanguard™ 3-Cylinder OHV Liquid-Cooled Gasoline Engines



Quality Starts With A
Master Service Technician



Equipment & Engine
Training Council



Powering Knowledge To Succeed

www.ThePowerPortal.com (Dealers)
BRIGGSandSTRATTON.COM (consumers)



0 24847 00631 5
MS-0750-5/10

BRIGGS&STRATTON
CORPORATION

POST OFFICE BOX 702
MILWAUKEE, WI 53201 USA
©2010 Briggs & Stratton Corporation

VANGUARD™ 3-CYLINDER OHV LIQUID-COOLED GASOLINE ENGINES 5/10

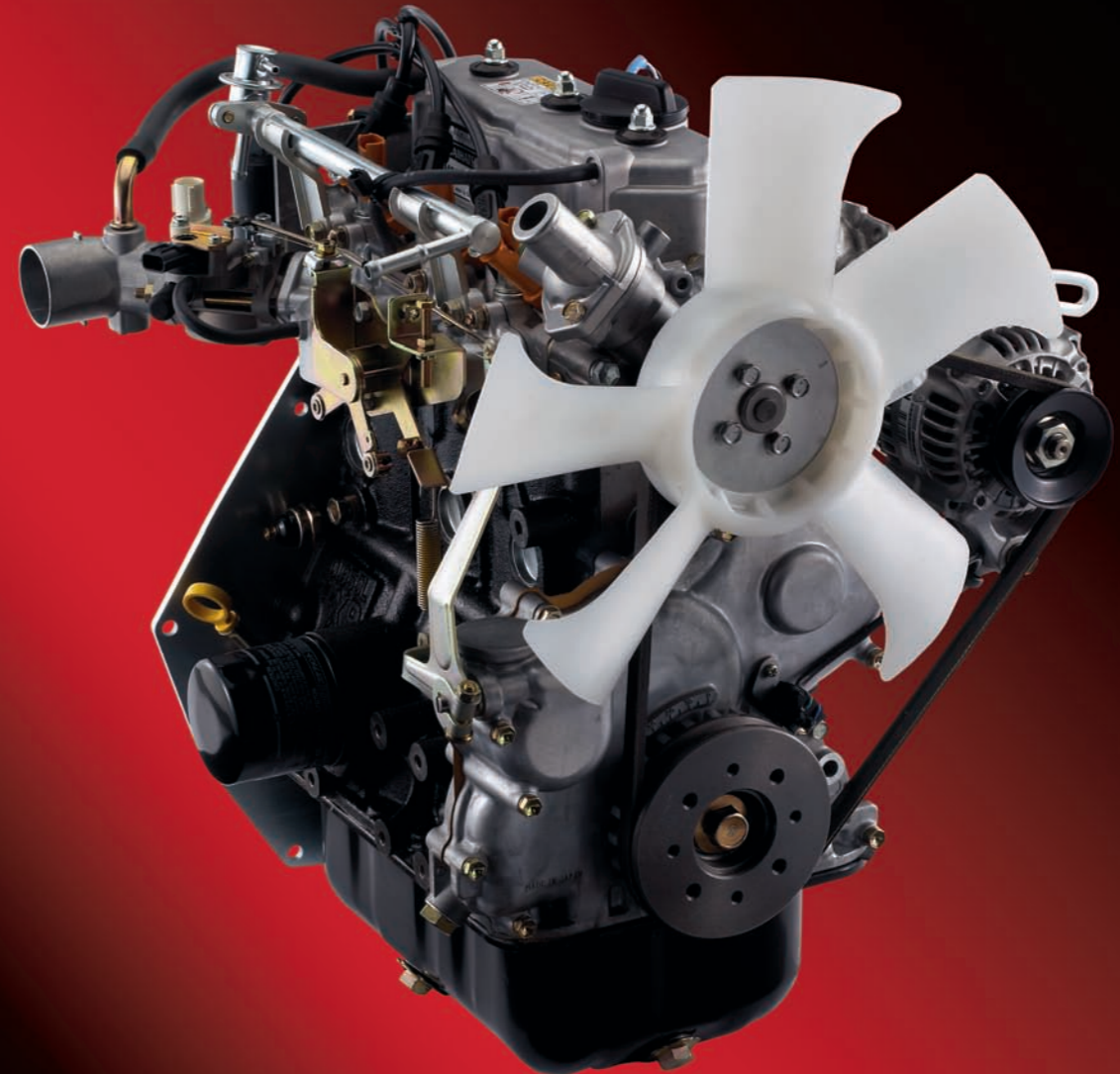

FORWARD

This manual was written to assist engine technicians and service personnel with the repair and maintenance procedures for Briggs & Stratton® engines. It assumes that persons using this manual have been properly trained in and are familiar with the servicing procedures for these products, including the proper use of required tools and safety equipment and the application of appropriate safety practices. Persons untrained or unfamiliar with these procedures or products should not attempt to perform such work.

Proper maintenance and repair is important to safe, reliable operation of all engines and engine-driven systems. The troubleshooting, testing, maintenance, and repair procedures described in this manual are appropriate for the Briggs & Stratton® engines described herein. Alternative methods or procedures may pose risk to personal safety and the safety and/or reliability of the engine and are not endorsed or recommended by Briggs & Stratton.

All information, illustrations, and specifications contained in this manual were based on the data available at the time of publication. Briggs & Stratton Corporation reserves the right to change, alter, or otherwise improve the product or the product manuals at any time without prior notice.

Briggs & Stratton offers two complementary publications to enhance understanding of engine technology, maintenance, and repair. (Neither publication, however, is a substitution for a recognized training program for engine technicians.)

- For consumers, *Small Engine Care & Repair* (p/n 274041) provides a comprehensive overview of how small air-cooled engines work, basic troubleshooting, and step-by-step maintenance procedures.
- For engine technicians and consumers alike, an in-depth study of engine theory and operation can be found in the textbook *Small Engines* (p/n CE8020).

Both publications can be purchased at BRIGGSandSTRATTON.COM or through a local Authorized Briggs & Stratton Service Dealer.

Copyright © 2010 Briggs & Stratton Corporation

All rights reserved.

No part of this manual may be reproduced or transmitted in any form or by any means, electronic or mechanical, including photocopying or recording by any information storage and retrieval system, without prior written permission from Briggs & Stratton Corporation.

This engine repair manual includes the following engine models:

- **MODEL 430000**
- **MODEL 580000**

SECTION 1 - Safety

1

SECTION 2 - Cylinder Heads and Valves

2

SECTION 3 - Governor, Timing Gears, and Gear Case

3

SECTION 4 - Flywheel and Rear Seal Retainer

4

SECTION 5 - Cylinder Block Disassembly

5

SECTION 6 - Cylinder Block Inspection and Repair

6

SECTION 7 - Crankshaft, Camshaft, and Bearings

7

SECTION 8 - Pistons, Rings, and Connecting Rods

8

SECTION 9 - Cylinder Block Assembly

9

SECTION 10 - Fuel System and Related Components

10

SECTION 11 - Ignition, Electrical System

11

SECTION 12 - Lubrication System

12

SECTION 13 - Cooling System

13

SECTION 14 - Engine Specifications

14

SECTION 1 - SAFETY AND MAINTENANCE

SAFETY INFORMATION 4

1

SAFETY INFORMATION

This repair manual contains safety information that is designed to:

- Make you aware of hazards associated with engines.
- Inform you of the risk of injury associated with those hazards.
- Tell you how to avoid or reduce the risk of injury.

1

Signal Words in Safety Messages

 The safety alert symbol is used to identify safety information about hazards that can result in personal injury.

A signal word (**DANGER**, **WARNING**, or **CAUTION**) is used with the alert symbol to indicate the likelihood and the potential severity of injury. In addition, a hazard symbol may be used to represent the type of hazard.

 **DANGER** indicates a hazard which, if not avoided, will result in death or serious injury.

 **WARNING** indicates a hazard which, if not avoided, could result in death or serious injury.

 **CAUTION** indicates a hazard which, if not avoided, could result in minor or moderate injury.

NOTICE indicates a situation that could result in damage to the product.

Prior to work, read and understand the section(s) of this manual that pertain to the job. Follow all safety warnings.

- Always use fresh gasoline. Stale fuel can cause gum deposits in the carburetor and cause leakage, flow restrictions, or other problems.
- Check fuel lines and fittings frequently for cracks or leaks and replace if necessary.

	WARNING
Before attempting to service this equipment, read and understand this manual and the operating instructions of the engine and the equipment it powers.	
Failure to follow instructions could result in property damage, serious injury (including paralysis) or even death.	

Hazard Symbols and Meanings



FIRE



EXPLOSION



ELECTRIC SHOCK



EXPLOSIVE PRESSURE



HOT SURFACE



GOGGLES



ENTANGLEMENT



KICKBACK



AMPUTATION



TOXIC FUMES



READ MANUAL



CHEMICAL BURNS

	WARNING
Battery posts, terminals, and related accessories contain lead and lead compounds - chemicals known to the State of California to cause cancer and reproductive harm. Wash hands after handling.	

 **WARNING**

Certain components in this product and its related accessories contain chemicals known to the State of California to cause cancer, birth defects, or other reproductive harm. Wash hands after handling.

 **WARNING**

Briggs & Stratton does not approve or authorize the use of these engines on 3-wheel All Terrain Vehicles (ATVs), motor bikes, fun/recreational go-karts, aircraft products, or vehicles intended for use in competitive events. Use of these engines in such applications could result in property damage, serious injury (including paralysis), or even death.

 **WARNING**

The engine exhaust from this product contains chemicals known the State of California to cause cancer, birth defects, and other reproductive harm.

 **WARNING**

 **Running engines produce heat. Severe burns can occur on contact.**

- Allow muffler, engine cylinder fins, and radiator to cool before touching.
- Remove accumulated combustibles from muffler area and cylinder area.
- It is a violation of California Public Resource Code, Section 4442, to use or operate the engine on any forest-covered, brush-covered, or grass-covered land unless the exhaust system is equipped with a spark arrester, as defined in Section 4442, maintained in effective working order. Other States and Federal jurisdictions may have similar laws. Contact the original equipment manufacturer, retailer, or dealer to obtain spark arrester designed for the exhaust system installed on this engine.

 **WARNING**

 **Fuel and its vapors are extremely flammable and explosive.**

 **Fire or explosion can cause severe burns or death.**

When adding fuel:

- Turn engine OFF and let engine cool for at least 2 minutes before removing the fuel cap.
- Fill fuel tank outdoors or in a well-ventilated area.
- Do not overfill fuel tank. To allow for expansion of the gasoline, do not fill above the bottom of the fuel tank neck.
- Keep gasoline away from sparks, open flames, pilot lights, heat and other ignition sources.
- Check fuel lines, tank, cap, and fittings frequently for cracks or leaks. Replace if necessary.
- If fuel spills, wait until it evaporates before starting engine.

When starting engine:

- Make sure spark plug, muffler, fuel cap, and air cleaner are in place.
- Do not crank engine with spark plug removed.
- If fuel spills, wait until it evaporates before starting engine.
- If engine floods, set choke (if equipped) to **OPEN/RUN** position. Place throttle (if equipped) in **FAST** and crank until engine starts.

When operating equipment:

- Do not tip engine or equipment at an angle which would cause fuel to spill.
- Do not choke carburetor to stop engine.
- Never start or run the engine with the air cleaner assembly (if equipped) or the air filter (if equipped) removed.

When changing oil:





- If you drain the oil from the top oil fill tube, the fuel tank must be empty or fuel can leak out and result in a fire or explosion.



When transporting equipment:



- Transport with fuel tank empty or with fuel shut-off valve set to OFF.



When storing gasoline or equipment with fuel in the tank:



- Store away from furnaces, stoves, water heaters, or other appliances that have a pilot light or other ignition source because they can ignite gasoline vapors.



	WARNING
	Unintentional sparking can result in fire or electrical shock.
	Unintentional start-up can result in entanglement, traumatic amputation, or severe lacerations.
	
Before performing adjustments or repairs:	
<ul style="list-style-type: none"> • Disconnect spark plug wire and keep it away from spark plug. • Disconnect the negative (-) battery terminal. 	
When testing for spark:	
<ul style="list-style-type: none"> • Use approved spark plug tester. • Do not check for spark with spark plug removed. 	



	WARNING
	Engines give off carbon monoxide, an odorless, colorless, poison gas. Breathing carbon monoxide can cause nausea, fainting, or death.
<ul style="list-style-type: none"> • Start and run engine outdoors. • Do not start or run engine in an enclosed area, even if doors and windows are open. 	

	WARNING
	Starting engine creates sparking. Sparking can ignite nearby flammable gases.
	Explosion and fire could result.
<ul style="list-style-type: none"> • If there is a natural or LP gas leak in the area, do not start engine. • Do not use pressurized starting fluids because vapors are flammable. 	

	WARNING
	Rotating parts can contact or entangle hands, feet, hair, clothing, or accessories.
	Traumatic amputation or severe lacerations can result.
<ul style="list-style-type: none"> • Operate equipment with guards in place. • Keep hands and feet away from rotating parts. • Tie up long hair and remove jewelry. • Do not wear loose-fitting clothing, dangling drawstrings, or items that could become entangled in the equipment. 	

	WARNING
	Charging batteries produce hydrogen gas. Do not store or charge a battery near an open flame or device that utilizes a pilot light or can create a spark.

	WARNING
	Damaged, worn, or loose fuel components can leak fuel. Explosion or fire could result.
	
<ul style="list-style-type: none"> • All fuel components should be in good condition and properly maintained. • Repairs should only be made with factory approved parts. • Repair work should be done by a qualified technician. • Flexible supply lines should be checked regularly to make sure they are in good condition. 	

	WARNING
	Rapid retraction of starter cord (kick-back) will pull hand and arm toward engine faster than you can let go. Broken bones, fractures, bruises, or sprains could result.
<ul style="list-style-type: none"> • When starting engine, pull the starter cord slowly until resistance is felt and then pull rapidly to avoid kickback. • Remove all external equipment/engine loads before starting engine. • Direct-coupled equipment components, such as but not limited to blades, impellers, pulleys, and sprockets, must be securely attached. 	

	WARNING
Prolonged or repeated contact with used motor oil could cause injury.	
<ul style="list-style-type: none"> • Used motor oil has been shown to cause skin cancer in certain laboratory animals. • Thoroughly wash exposed areas with soap and water. 	

SECTION 2 - CYLINDER HEAD AND VALVES

REMOVE CYLINDER HEAD	9
DISASSEMBLE CYLINDER HEAD	10
REMOVE VALVES	11
INSPECT CYLINDER HEAD	12
DISASSEMBLE ROCKER ARM SHAFT	15
ASSEMBLE ROCKER ARM SHAFT	16
ASSEMBLE CYLINDER HEAD	17
INSTALL CYLINDER HEAD	18
ADJUST VALVES	20

2

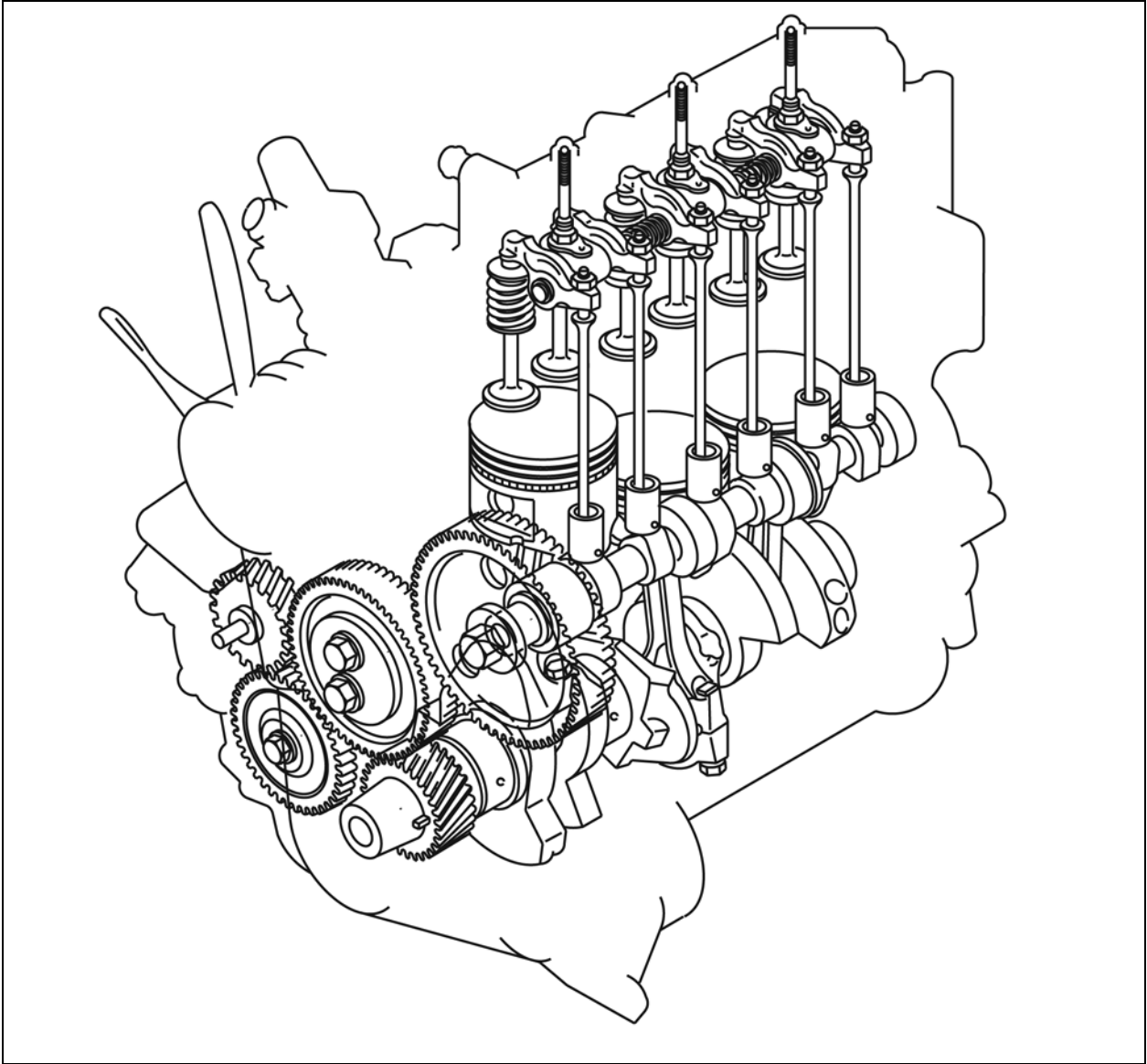

Remove Cylinder Head

1. Drain cooling system and disconnect radiator hoses and bypass hose at water pump.
2. Remove the alternator adjusting bracket screw (A, Figure 1), V-belt (B), and fan (C), from the engine.

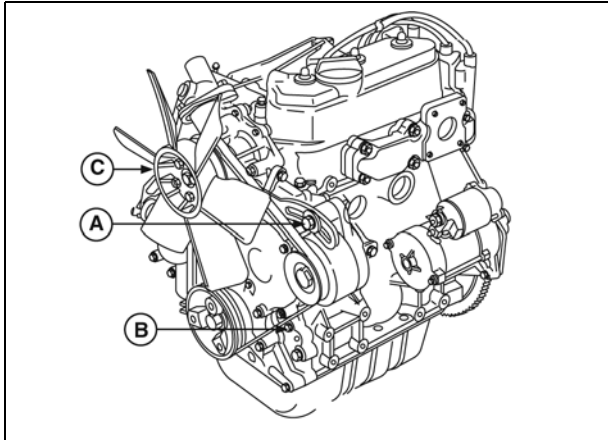

Figure 1

3. Remove the water pump pulley (A, Figure 2), water pump (B), and exhaust manifold (C) from the engine.

NOTE: Remove the exhaust system before removing exhaust manifold.

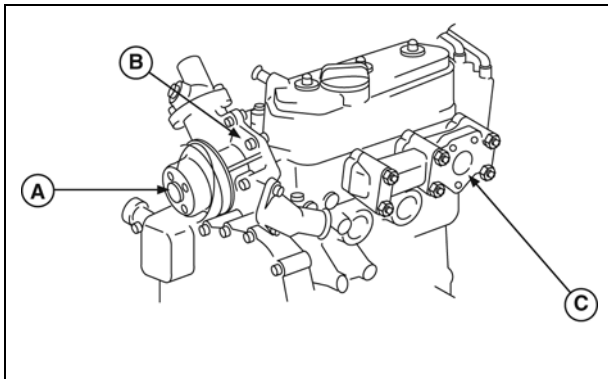

Figure 2

4. Remove the fuel line (A, Figure 3) and governor link and spring (B).
5. Remove the intake manifold (C) and spark plug wires and spark plugs (D).

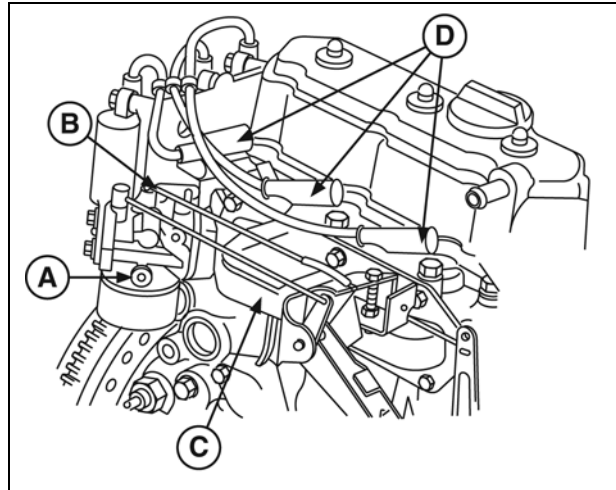

Figure 3

6. Remove the ignition coil bracket (Figure 4) and the ignition coils.

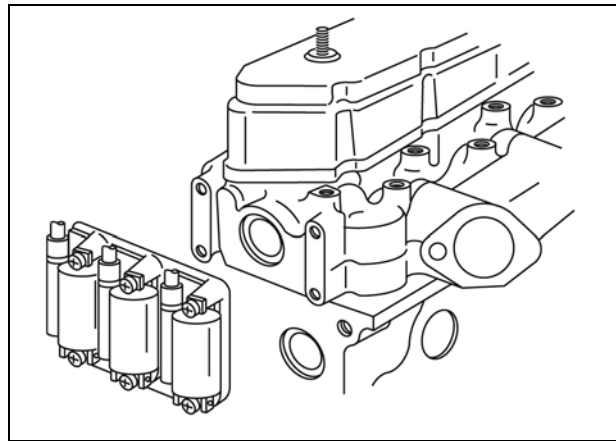

Figure 4

7. Remove the valve cover (Figure 5).

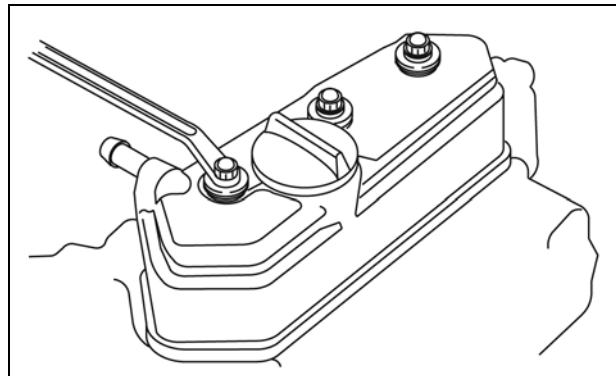

Figure 5

8. Set the Number 1 piston at Top Dead Center (TDC).

9. Rotate crankshaft pulley until timing mark on pulley is aligned with reference point (A, Figure 6) on timing cover (B).

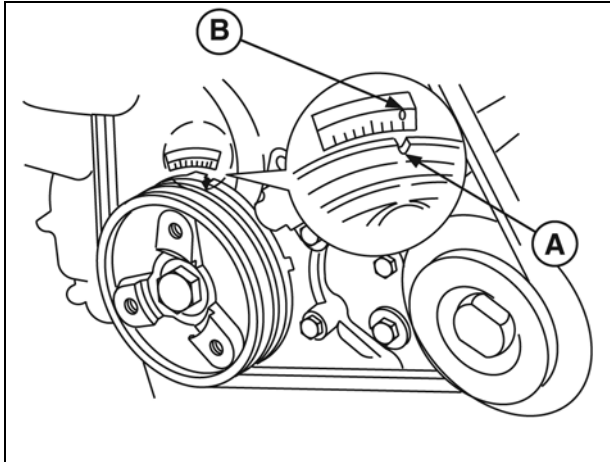

Figure 6

- If intake and exhaust valves have clearance, the Number 1 piston is at TDC (compression stroke).
- If intake and exhaust valves do not have clearance, turn crankshaft pulley one complete revolution. Valves will then have clearance.

10. Remove rocker arm assembly (A, Figure 7) and push rods.

11. Remove valve stem caps (B).

NOTE: Mark push rods so that they may be reassembled in their original position.

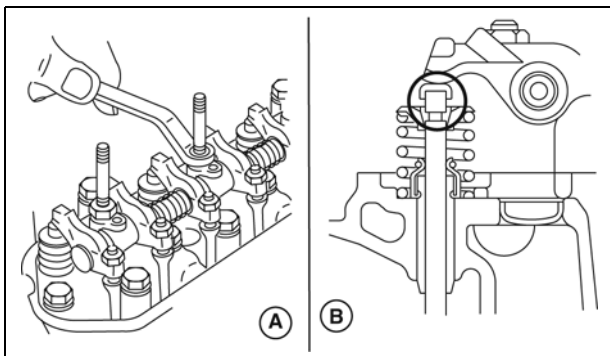

Figure 7

Disassemble Cylinder Head

1. Loosen cylinder head bolts in the order shown (Figure 8).

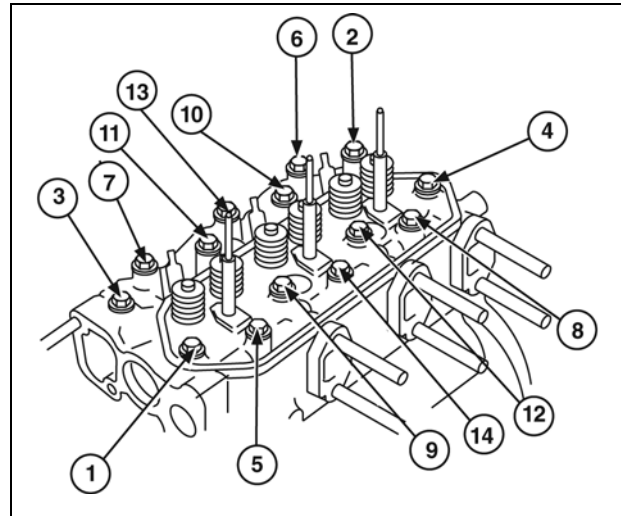

Figure 8

Remove Valves

2. Refer to the following cylinder head components (Figure 9) when proceeding to the next part of the disassembly process:

- (A) - Cylinder Head Assembly
- (B) - Cylinder Head Gasket
- (C) - Valve Stem Cap
- (D) - Valve Spring Retainer Locks
- (E) - Valve Spring Retainer
- (F) - Valve Spring
- (G) - Valve
- (H) - Valve Spring Seat
- (J) - Valve Stem Seal
- (K) - Valve Guide

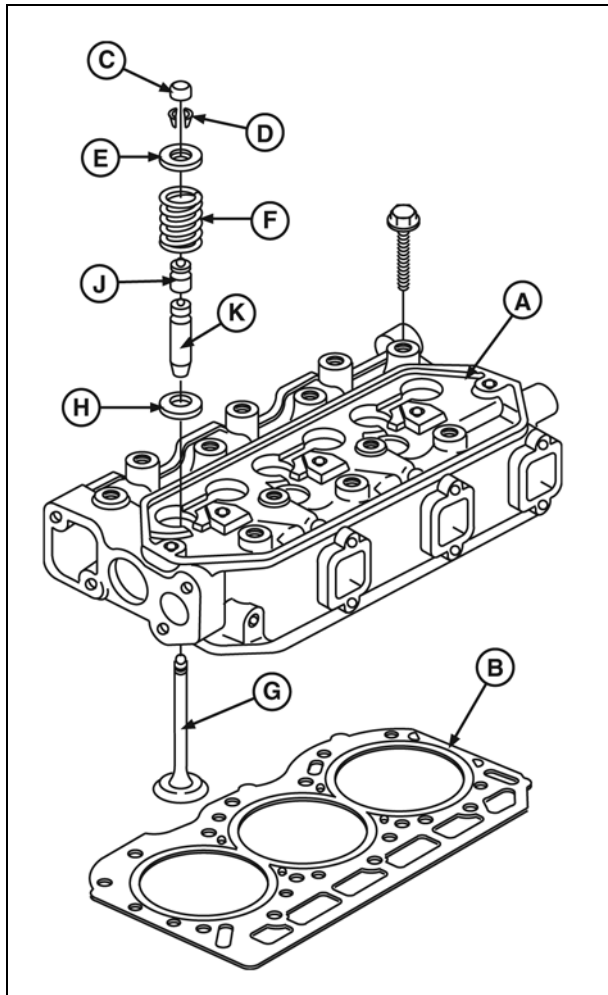

Figure 9

3. Remove valves (Figure 10).

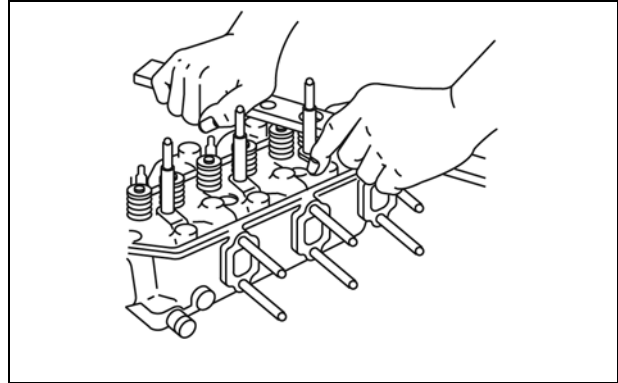

Figure 10

NOTE: Place a shop rag or short section of fuel line under valves inside combustion chamber to hold valve in place while compressing spring.

4. Use Valve Spring Compressor #19417 to compress valve springs. Remove the following parts:

- Valve Spring Retainer Locks
- Valve Spring Retainer
- Valve Spring
- IN and EX valve
- Valve spring seats

5. Remove and discard valve stem seals (Figure 11).

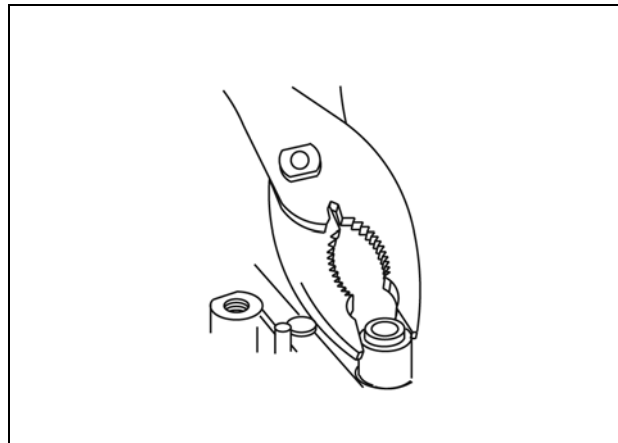

Figure 11

Inspect and Repair

Inspect Cylinder Head

NOTE: Be sure all gasket material is removed from surfaces before checking. Use a gasket scraper if necessary.

1. Inspect cylinder head for cracks or damage.
2. Use a straight edge (**A**, Figure 12) to check cylinder head lower surface for distortion.

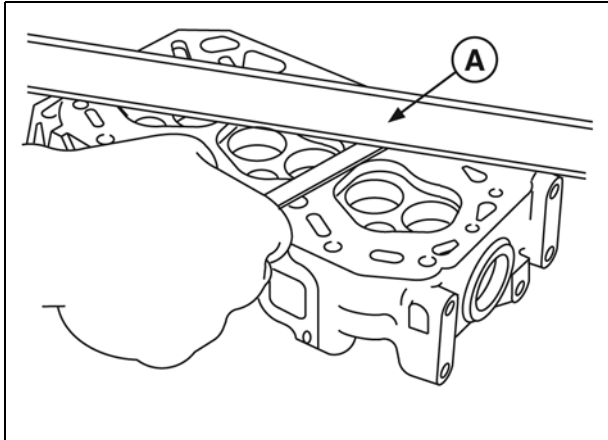

Figure 12

3. If mounting surfaces are distorted more than 0.1 mm (0.004 in), the cylinder head must be replaced (Figure 13).

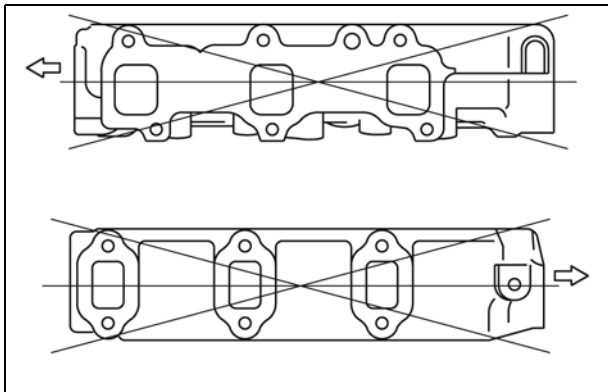

Figure 13

NOTE: It is not recommended that cylinder head mounting surfaces be resurfaced.

4. Inspect intake and exhaust manifold mounting surfaces in the same manner. Use same specifications as cylinder head.
5. Inspect valve guide bushing for damage. Check valve guide bushings for wear using Reject Gauge #19382, (**A**, Figure 14).

- Replace if damaged or if reject gauge enters valve guide.

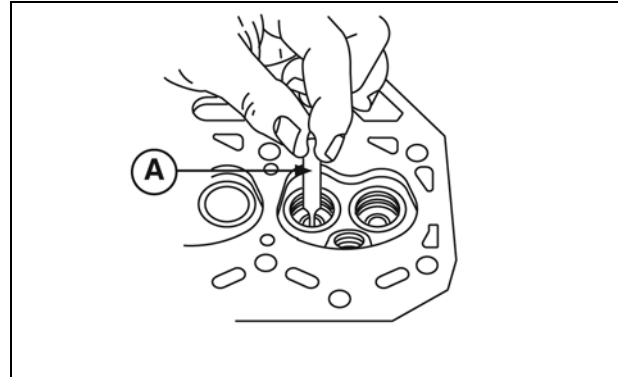

Figure 14

6. Use Bushing Driver #19367, and press out valve guide bushing from combustion chamber (Figure 15).

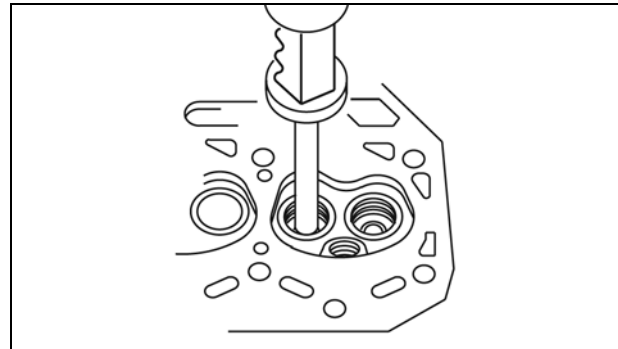

Figure 15

7. Check valve guide bushing OD. Then compare with the following specifications:
 - Standard Bushing OD: 11.05 mm (0.435 in.)
 - Replacement Bushing OD: 11.08 mm (0.4362 in.)
8. If bushing OD measurement indicates that a replacement bushing has already been installed, the cylinder head must be replaced.
9. Using Bushing Driver #19416, press in new valve guide bushing until tool bottoms on cylinder head (Figure 16).

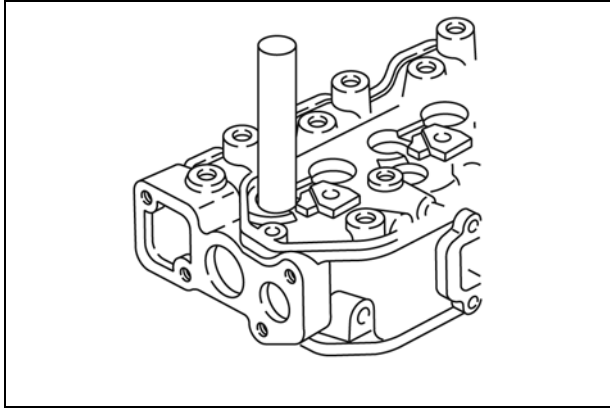

Figure 16

10. Valve faces may be resurfaced to 30°. Check valve seat dimensions before resurfacing. (A, Figure 17) should be 0.05 - 0.06" (1.2 - 1.6mm) and (B) should be at least 0.0312".

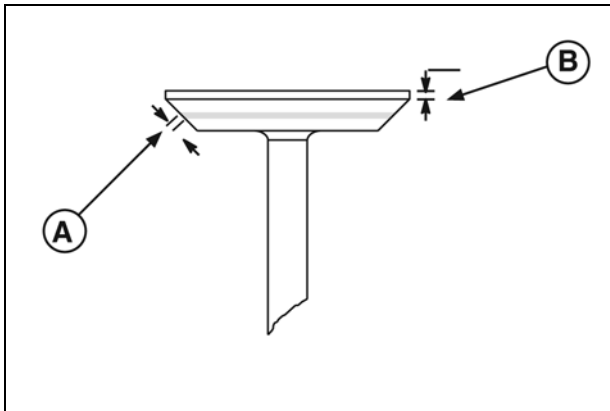

Figure 17

- Lap valves and seats with Valve Lapping Tool #19258 and Valve Lapping Compound #94150.

11. Valve seats may be reconditioned using Valve Seat Cutter #19446.

NOTE: Inspect valve guide bushings first. If valve guides are worn, they must be replaced before refacing valve seats.

If valve seat is wider than 0.05 - 0.06" (1.2 - 1.6mm) (A, Figure 18), a narrowing cutter should be used to ensure that contact area of valve seat is centered on face of valve.

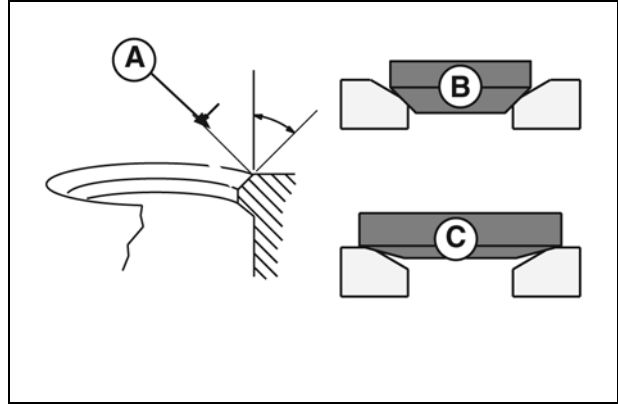

Figure 18

- Use a 45° (B) cutter to narrow seat from bottom.
- Use a 15° (C) cutter to narrow seat from top.

NOTE: If valve seat is loose or cracked, replace cylinder head.

12. Measure valve stem diameter at specified distance from end of valve (A, Figure 19).

- **Replace IN** if less than 0.2343 in. (5.952 mm).
- **Replace EX** if less than 0.2342 in. (5.948 mm).

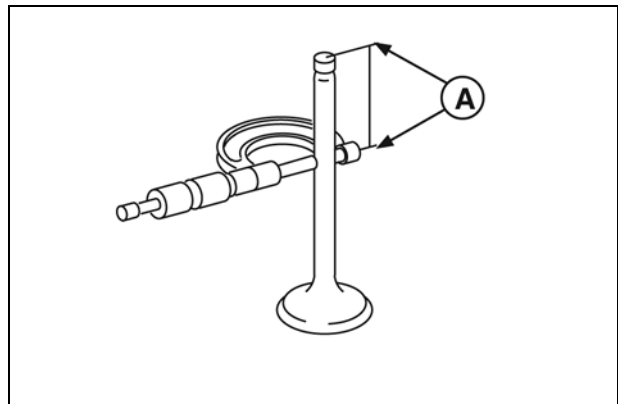

Figure 19

13. Inspect valve stem cap for wear (Figure 20). Replace if cap is worn recessed.

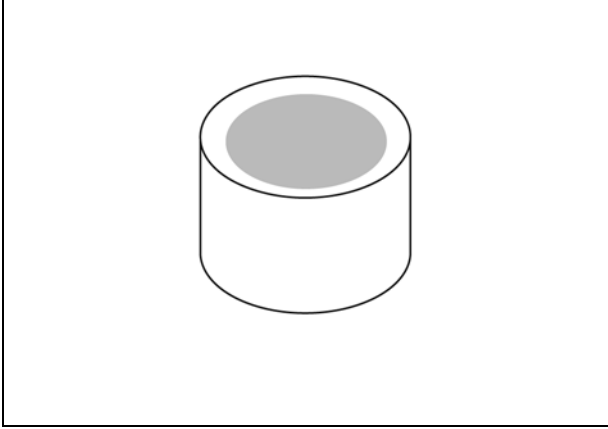

Figure 20

14. Inspect valve springs for squareness and free length (Figure 21).

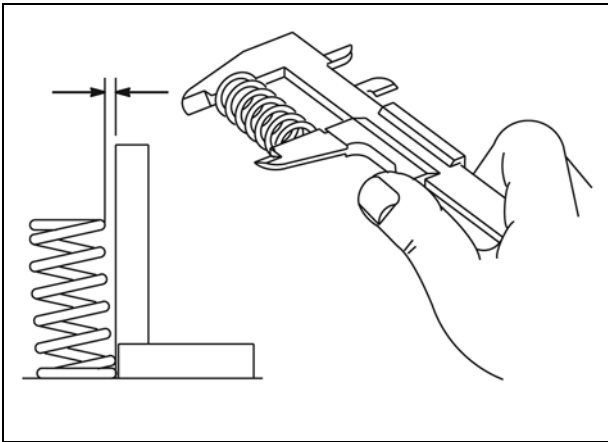

Figure 21

- Replace if out of square more than 0.040 in. (1.0 mm).
- Replace if free length is less than 0.150 in. (29.2 mm).

Disassemble Rocker Arm Shaft

Remove snap rings (**A**, Figure 22) from ends of rocker arm shaft (**B**). Remove set screw (**C**) from center rocker arm support (**D**). Disassemble rocker arm assembly. Note position of rocker arms (**E**), thrust washers (**F**) and springs (**G**).

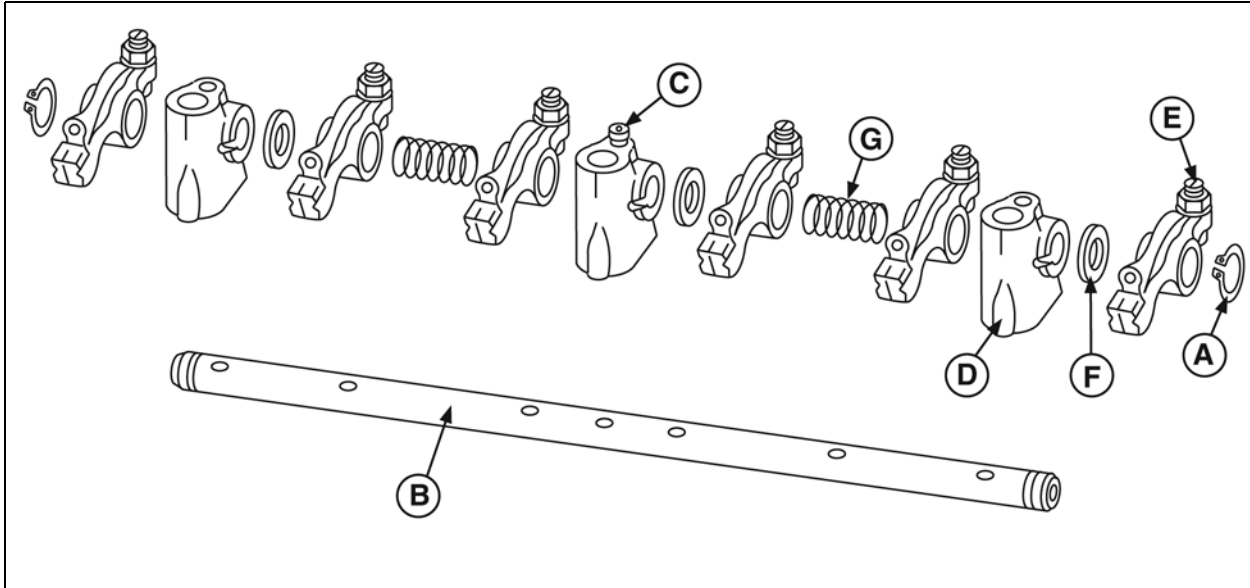

Figure 22

1. Check rotor arms and shaft (Figure 23).

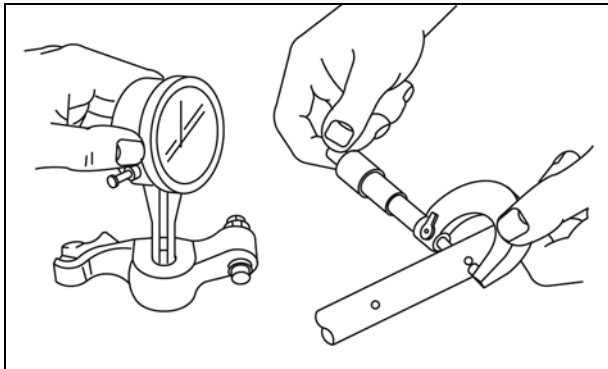

Figure 23

2. Check rocker arm bearing. Replace if greater than 0.395 in. (10.03 mm).
3. Check rocker arm shaft. Replace if less than 0.392 in. (9.957 mm).
4. Check rocker arm studs for stripped threads and replace if required.

Assemble Rocker Arm Shaft

1. Oil all components before assembling.
2. Small grooves in rocker shaft (**A**) next to oil holes (**B**) must face down.
3. Assemble rocker arm (**G**) components, noting order of assembly shown in Figure 24.

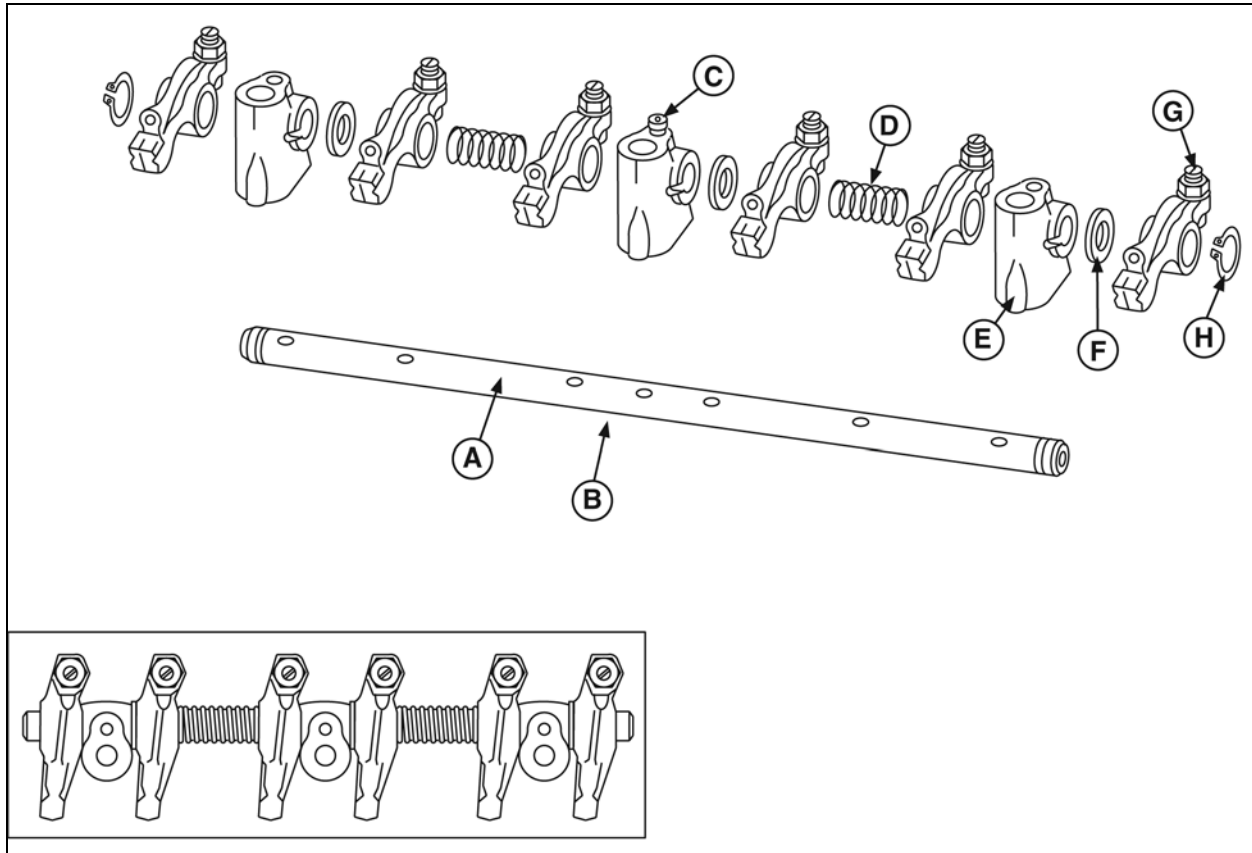

Figure 24

4. Note position of three thrust washers (**F**), springs (**D**), snap rings (**H**)
5. Install set screw (**C**) in center rocker arm shaft support (**E**).

Assemble Cylinder Head

Cylinder Head Components (Figure 25)

- (A) - Cylinder Head
- (B) - Cylinder Head Gasket
- (C) - Valve Stem Cap
- (D) - Valve Spring Retainer Locks
- (E) - Valve Spring Retainer
- (F) - Valve Spring
- (G) - Valve
- (H) - Valve Spring Seat
- (J) - Valve Stem Seal
- (K) - Valve Guide
- (L) - Push Rod
- (M) - Rocker Arm Assembly
- (N) - Rocker Arm Stud

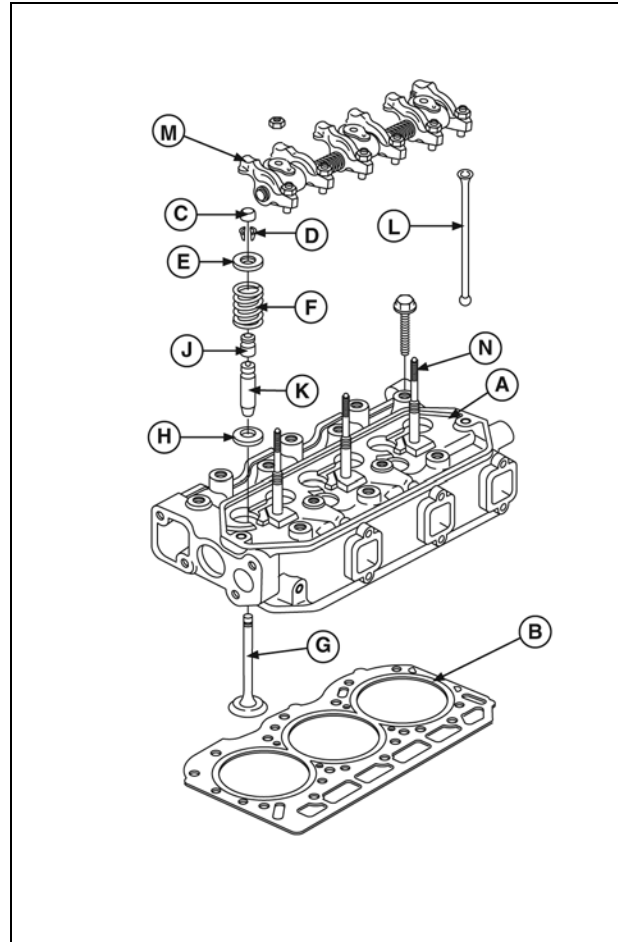

Figure 25

1. Install new valve stem seals (A, Figure 26). Oil inner surface and lip of seal before installing. Press seal on to valve guide bushing until it bottoms.

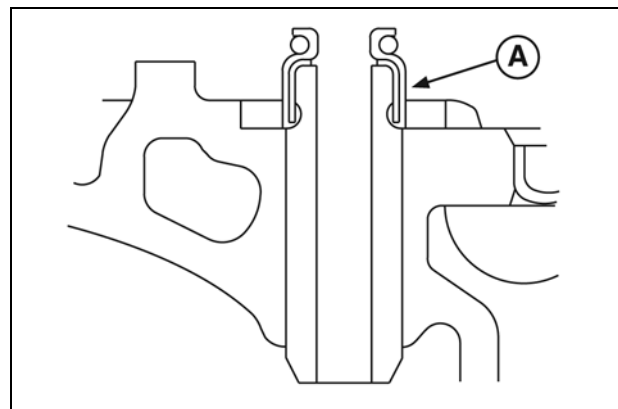

Figure 26

2. Install valve spring seats (Figure 27).

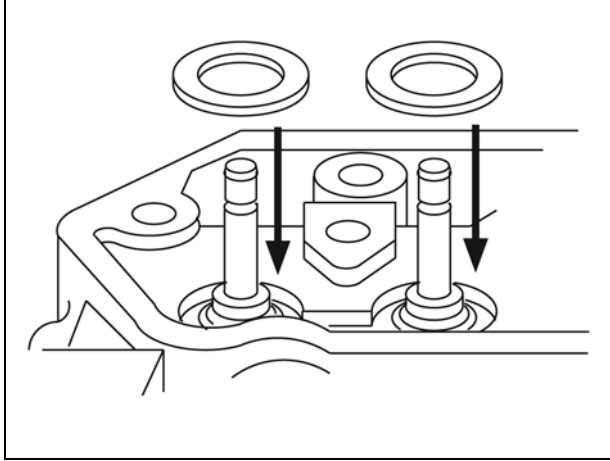

Figure 27

NOTE: Lightly coat valve stems with Valve Guide Lubricant #93963, before installing valves.

3. Install valves.
4. Install valve springs (Figure 28) with Valve Spring Compressor #19417.

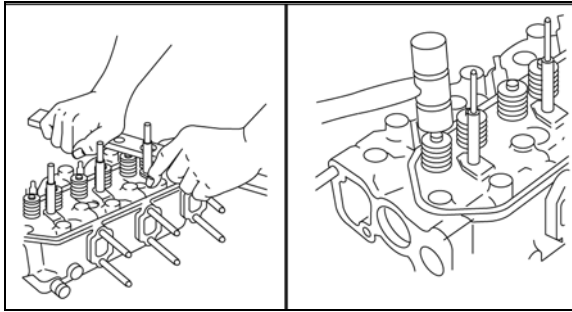

Figure 28

NOTE: After installing valve spring retainer locks, tap valve spring retainer lightly with a soft hammer to ensure locks are seated.

Install Cylinder Head

1. Place cylinder head gasket over alignment dowels on cylinder block (Figure 29).

NOTE: Make sure coolant, oil passages, and head bolt holes are aligned.

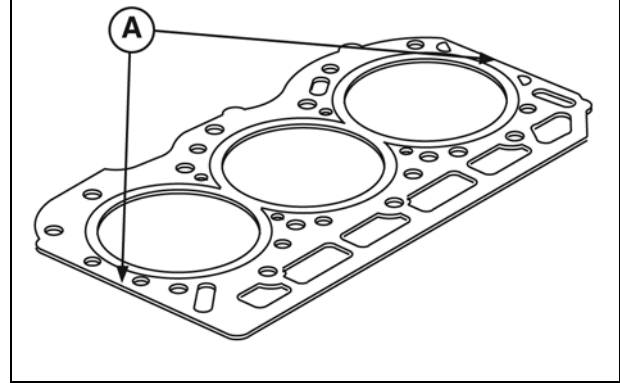

Figure 29

2. Install cylinder head assembly.
3. Lubricate threads of cylinder head bolts with engine oil.
4. Torque head bolts in 10 ft. lbs. (13.0 Nm) increments in sequence shown (Figure 30).

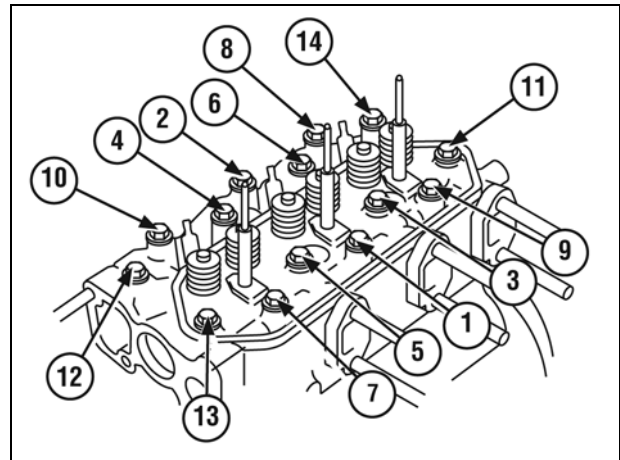

Figure 30

NOTE: Current style head bolts are 9 mm diameter. Early style head bolts are 8 mm diameter. Torque specifications are different. Torque bolts to values listed in Section 14 - Engine Specifications.

5. Lubricate push rods with engine oil then install with recessed end up.
6. Install valve stem caps on valve stems. Install rocker arm assembly (Figure 31).

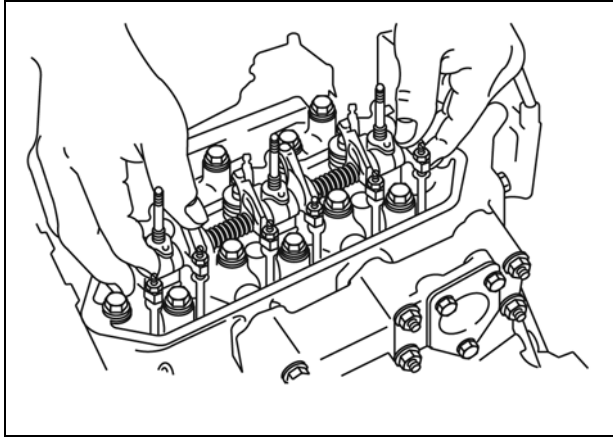

Figure 31

7. Install washers and torque nuts to values listed in Section 14 - Engine Specifications.

NOTE: Make sure rocker adjustments studs are seated in recessed end of push rods.

Install ignition coil bracket and ignition coils (Figure 32). Torque screws to values listed in Section 14 - Engine Specifications.

8. Install ignition coil bracket and ignition coils (Figure 32). Torque screws to values listed in Section 14 - Engine Specifications.

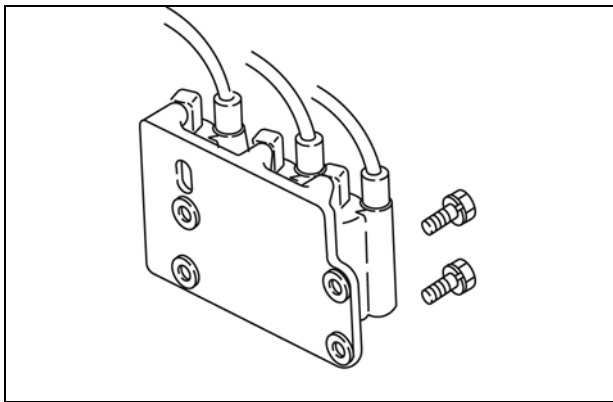

Figure 32

9. Install intake manifold with new gasket. Install governor link and spring (Figure 33). Torque screws to values listed in Section 14 - Engine Specifications.

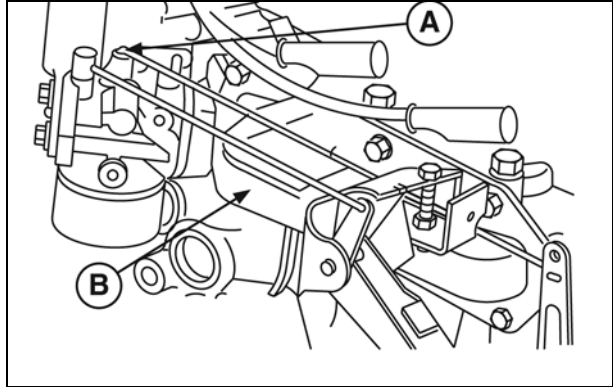

Figure 33

10. Insert governor spring into original hole in governor lever.

NOTE: Normal spring position is in center hole in the governor lever (Figure 34).

NOTE: Governor spring must be installed in correct hole in governor control lever by engine model.

- Model 430400 - Top Hole
- Model 580400 - Bottom Hole

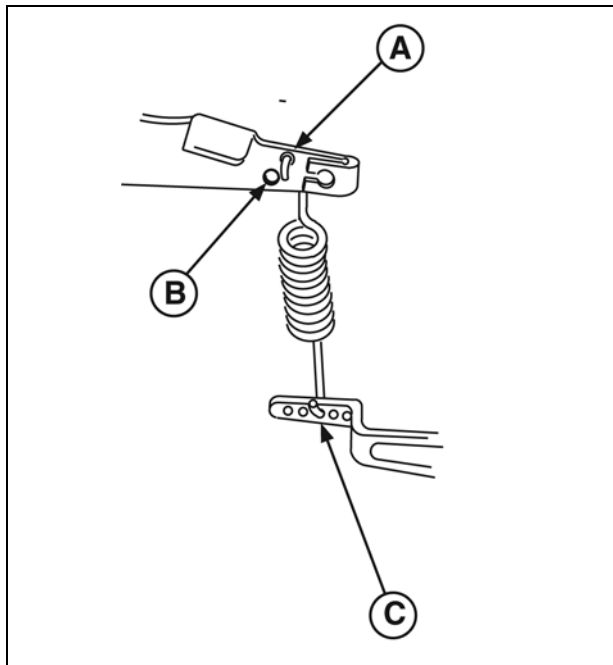

Figure 34

11. Install exhaust manifold with new gasket (Figure 35). Torque screws to values listed in Section 14 - Engine Specifications.

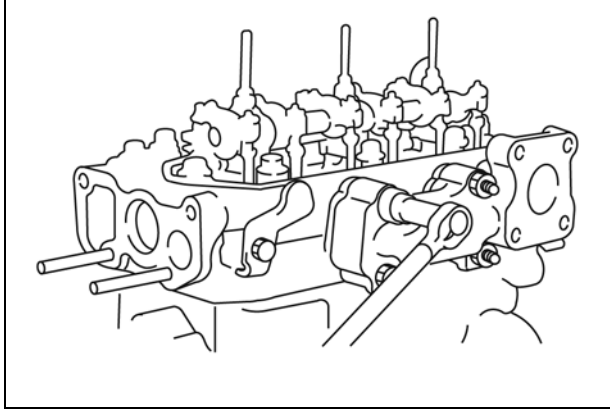

Figure 35

12. Install water pump with new gasket (Figure 36). Torque screws and nuts to values listed in Section 14 - Engine Specifications.

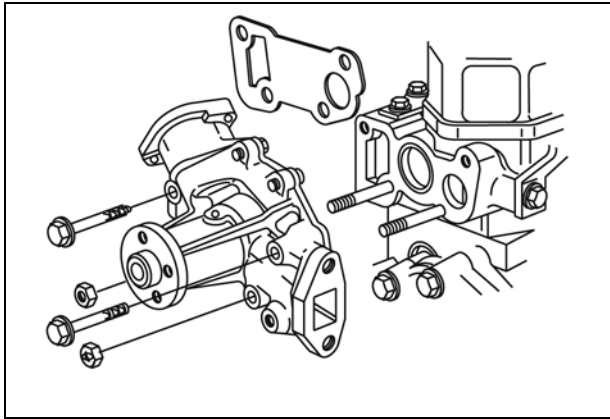

Figure 36

13. Install water pump pulley (Figure 37). Install fan (if equipped). Torque screws to values listed in Section 14 - Engine Specifications.

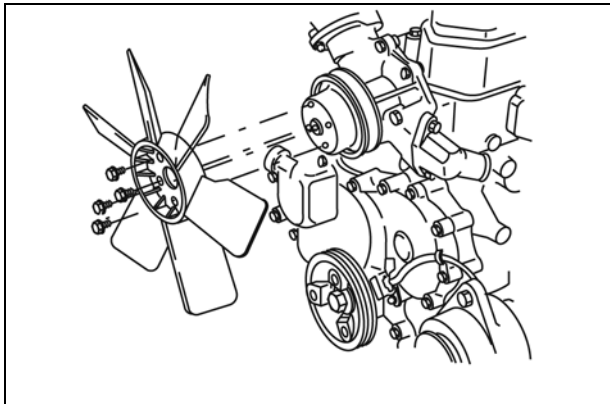

Figure 37

14. Install V-belt (Figure 38). Install alternator adjusting bolt. Torque bolt to values listed in Section 14 - Engine Specifications.

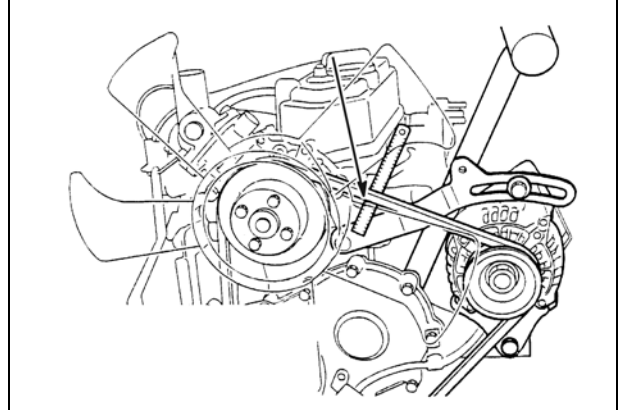

Figure 38

NOTE: Belt deflection limit is 3/8-1/2 in./22 lb. (10.0-12.0 mm/10 kg).

Adjust Valves

1. Before adjusting valves, make sure that the Number 1 cylinder is at Top Dead Center (TDC) - Compression Stroke (Figure 39).

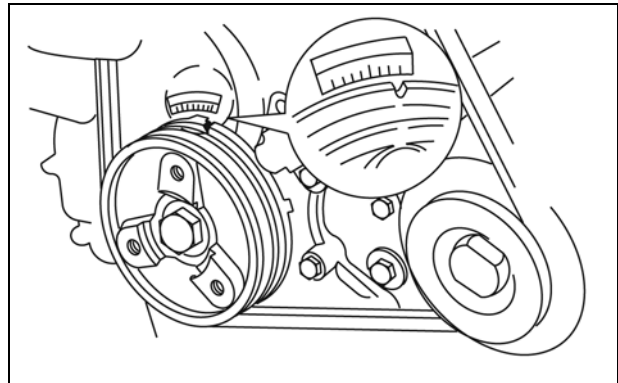

Figure 39

2. Adjust valves and check (Figure 40).
 - Valve Clearance (cold) IN and EX - 0.007 in. (0.18 mm).
 - Torque adjusting screws and jam nuts to values listed in Section 14 - Engine Specifications.

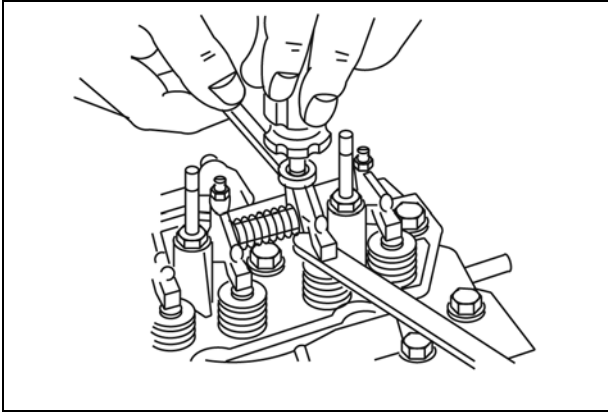

Figure 40

- 3. With Number 1 piston at TDC of compression stroke, check and adjust valve clearances for cylinders (Figure 41).
- 4. Rotate crankshaft one complete turn 360° clockwise to check and adjust remaining valves.
- 5. Install valve cover (Figure 41). Torque cover nuts to values listed in Section 14 - Engine Specifications.

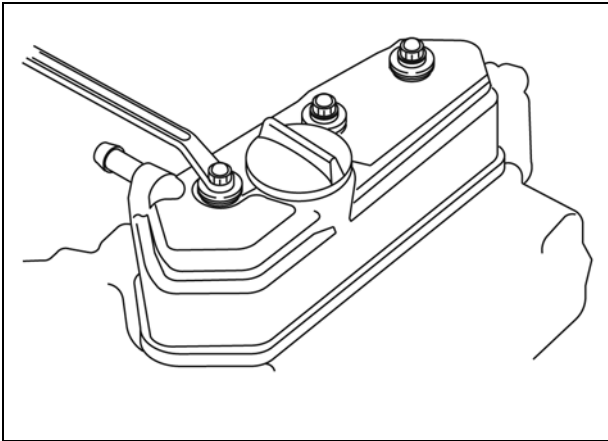

Figure 41

- 6. Install spark plugs. Torque spark plugs to values listed in Section 14 - Engine Specifications.

SECTION 3 - GOVERNOR, TIMING GEARS, AND GEAR CASE

REMOVE TIMING GEAR COVER AND GEARS	-24
INSPECT GEARS	-25
REMOVE GEAR CASE	-26
DISASSEMBLE GOVERNOR SHAFT ASSEMBLY	-27
REPLACE TIMING GEAR COVER OIL SEAL	-27
ASSEMBLE GOVERNOR SHAFT ASSEMBLY	-27
ASSEMBLE TIMING GEAR CASE AND GEARS	-28
ADJUST GOVERNOR	-31
TROUBLESHOOTING	-31
ELECTRONIC GOVERNOR	-32
INSPECT GOVERNOR ACTUATOR	-33
REMOVE GOVERNOR ACTUATOR	-33
INSTALL GOVERNOR ACTUATOR	-33



TIMING GEARS, GEAR CASE, ELECTRONIC GOVERNOR

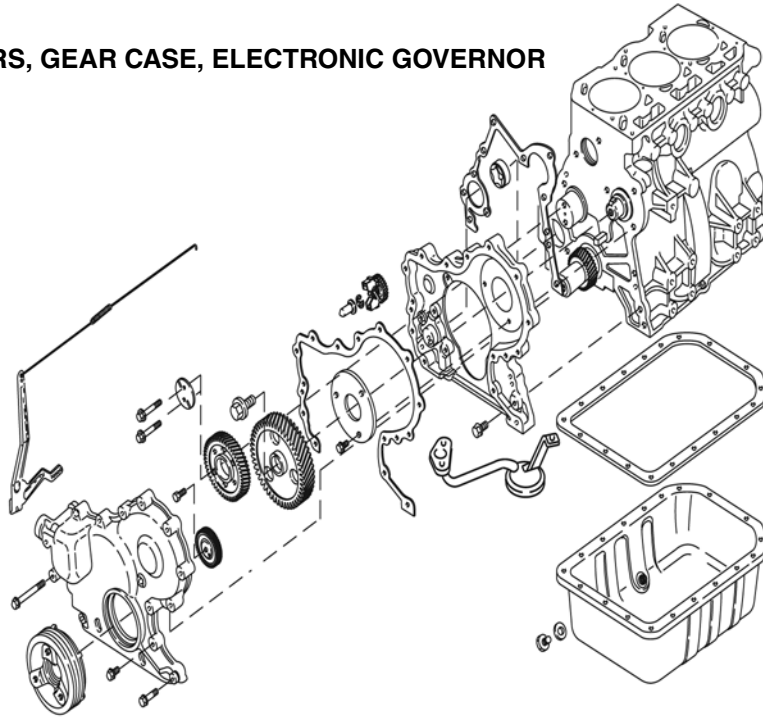

Remove Timing Gear Cover and Gears

NOTE: Make sure the Number 1 cylinder is at Top Dead Center (TDC), compression stroke. See Section 2.

1. Remove V-belt and fan (if equipped).
2. Drain oil from engine.

NOTE: Before removing governor spring, note hole position of governor spring in governor lever.

3. Remove governor link spring (A, Figure 1) and governor link from carburetor.
4. Remove governor spring from governor lever (B).
5. Loosen nut (C) and remove governor lever from governor shaft.

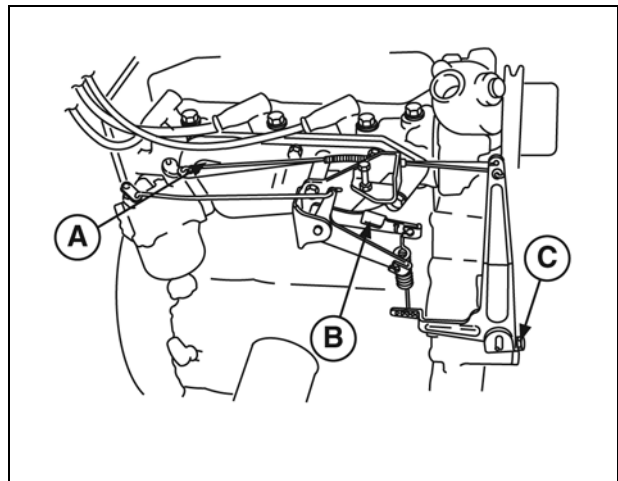

Figure 1

6. Remove oil pan screws and nuts.
7. Remove oil pan and discard gasket.
8. Remove oil pick-up tube (A, Figure 2) and strainer. Discard gasket.

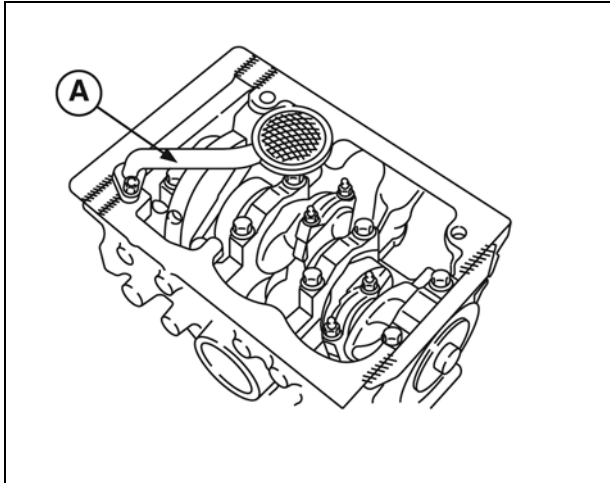

Figure 2

9. Remove bell housing adapter screw (if equipped) and install Flywheel Holder #19418 (A, Figure 3).

NOTE: Leave tool installed.

10. Remove crankshaft pulley using Tool #19420 (B).

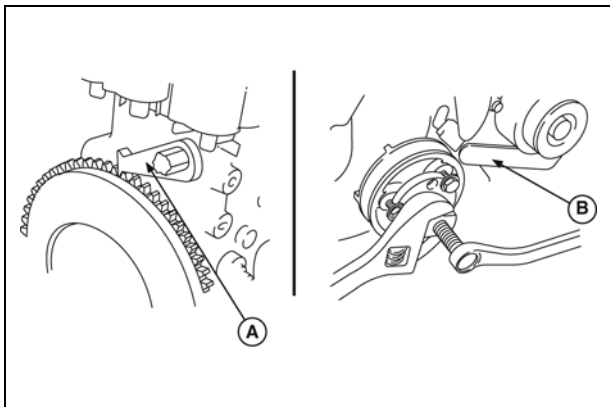

Figure 3

11. Remove trigger (A, Figure 4) and wire. Remove timing gear cover (B) and discard timing gear gasket.

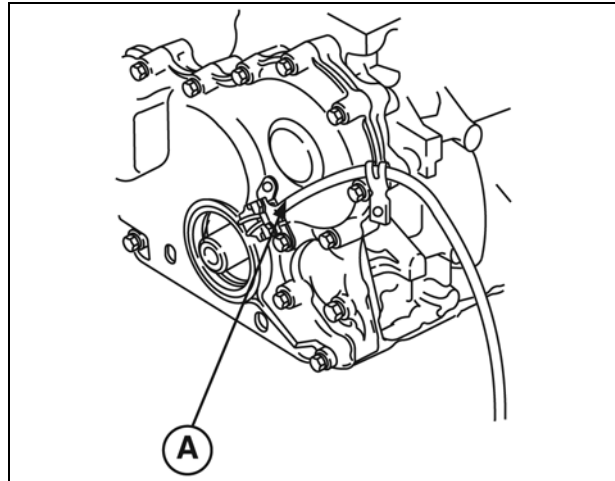

Figure 4

12. Remove governor gear (A, Figure 5), governor cup (B), E-ring (C), governor gear (D), and thrust washer (E).
13. Remove oil pump drive gear (F).

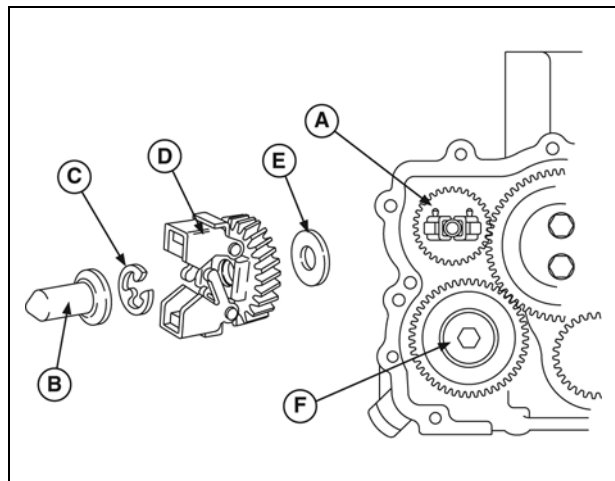

Figure 5

14. Check governor gear and oil pump drive gear for damaged teeth.

Inspect Gears

1. Inspect gear teeth for wear or damage.
2. Check gear back lash between idler gear (A, Figure 6) and crankshaft gear (B) using a dial indicator.
 - Set tip of indicator on gear tooth, then rock idler gear back and forth noting indicator reading.
 - Crankshaft must not turn while checking.

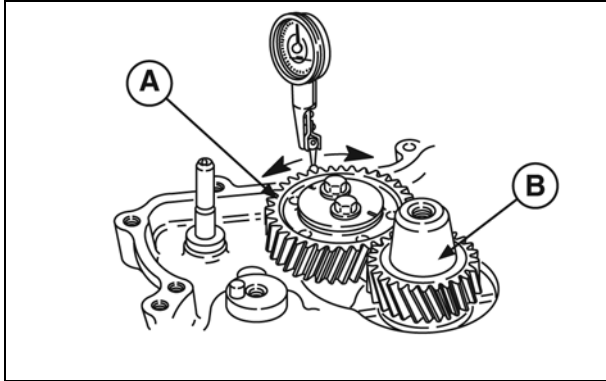

Figure 6

3. If back lash exceeds 0.008 in. (0.2 mm) check idler gear bearing and shaft for wear (Figure 7).

Reject dimensions for Idler Gear:

- ID - 0.345 in. (34.17 mm)
- OD - 1.335 in. (33.91 mm)

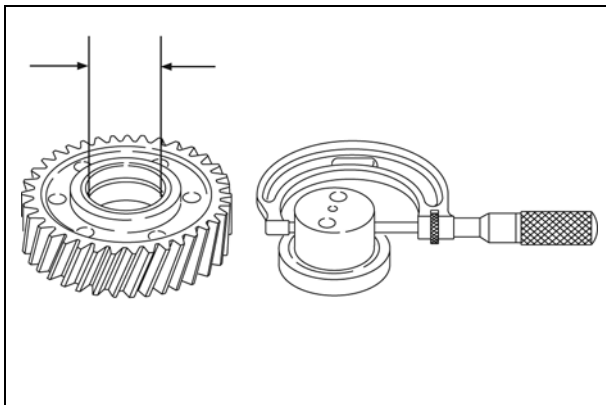

Figure 7

4. If idler gear bearing and shaft are within specification, replace with new idler gear and recheck.
5. If back lash exceeds 0.008 in. (0.2 mm) with NEW idler gear, crankshaft gear is worn.

NOTE: If crankshaft gear is worn the crankshaft must be replaced.

6. Hold idler gear and check gear backlash between camshaft timing gear (A, Figure 8) and idler gear (B) using a dial indicator.

NOTE: Idler gear must not turn while checking.

7. If gears are worn, it is recommended that they be replaced as a set.

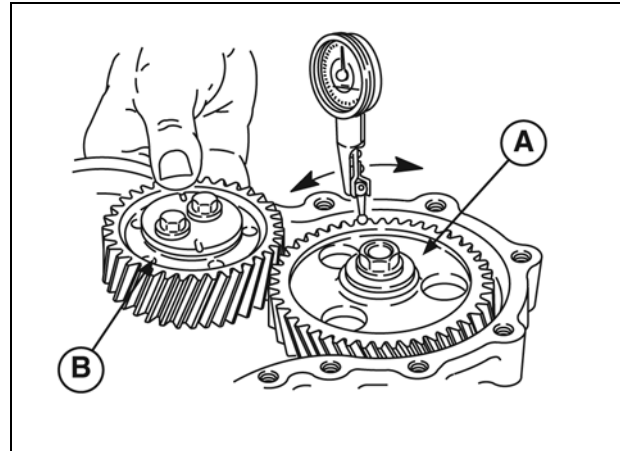

Figure 8

Remove Gear Case

1. Remove three screws (A, Figure 9) and camshaft retainer.
2. Remove remaining five screws (B).

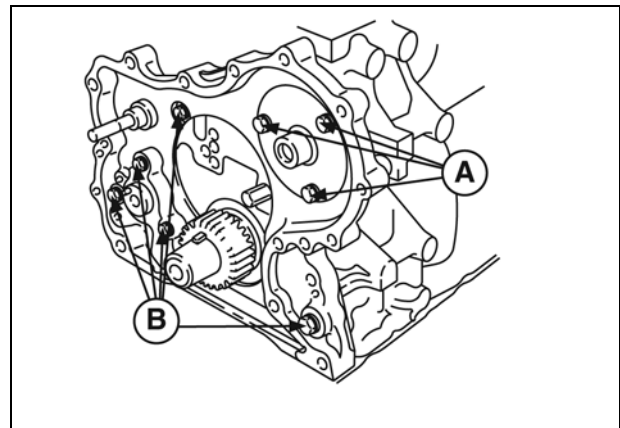

Figure 9

3. Remove timing gear case and discard gasket.
4. Remove oil pump rotor (Figure 10) from cylinder block.

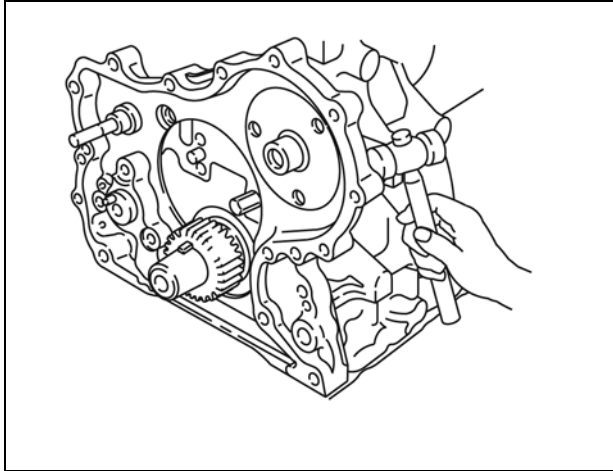

Figure 10

Disassemble Governor Shaft Assembly

1. Remove cotter pin (A, Figure 11) and washer (B). Discard cotter pin.
2. Remove screws (C) and governor paddle (D) using Torx® Driver #19445. Discard screws.

NOTE: Governor paddle screws are Torx® tamper proof screws.

3. Remove shaft (E) and spacer (F).
4. Remove and discard oil seal (G).

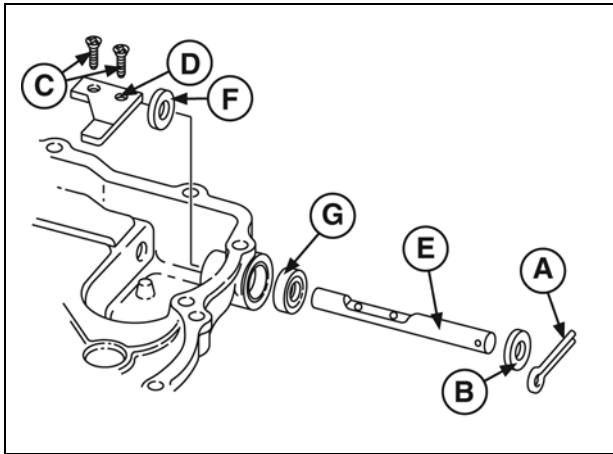

Figure 11

Replace Timing Gear Cover Oil Seal

1. Drive out oil seal.
2. Use Seal Driver #19423 to install new oil seal (Figure 12).

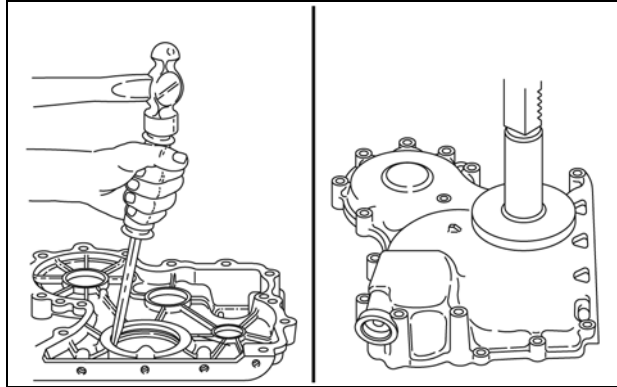

Figure 12

Assemble Governor Shaft Assembly

1. Install thrust washer (A, Figure 13) on shaft followed by the governor gear (B), E-ring (C), and governor cup (D).

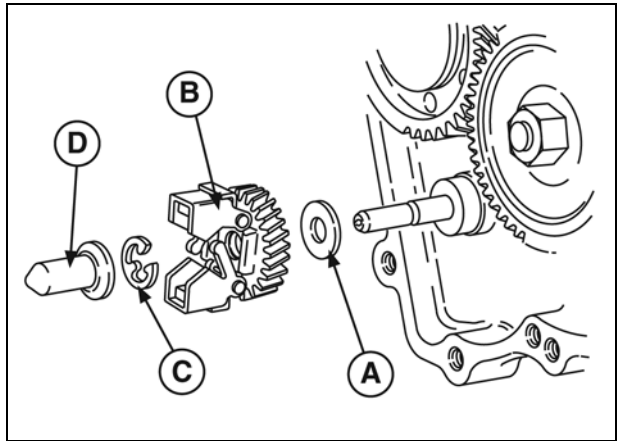

Figure 13

NOTE: Lubricate governor shaft with engine oil before installing.

2. Install new oil seal (A, Figure 14) with seal lips in.
3. Install governor shaft (B) and spacer (C).
4. Install governor paddle (D) using new screws (E). Use Torx® Driver #19445. Torque to values listed in Section 14 - Engine Specifications.
5. Install washer (F) and new cotter pin (G).

NOTE: Governor shaft must rotate freely.

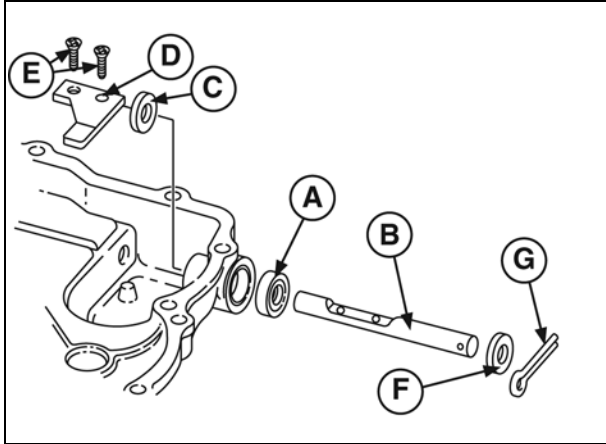

Figure 14

Assemble Timing Gear Case and Gears

1. Clean and lubricate oil pump rotor (**A**, Figure 15) with engine oil and install on cylinder block.

NOTE: ID mark (**B**) on rotor must face cylinder block.

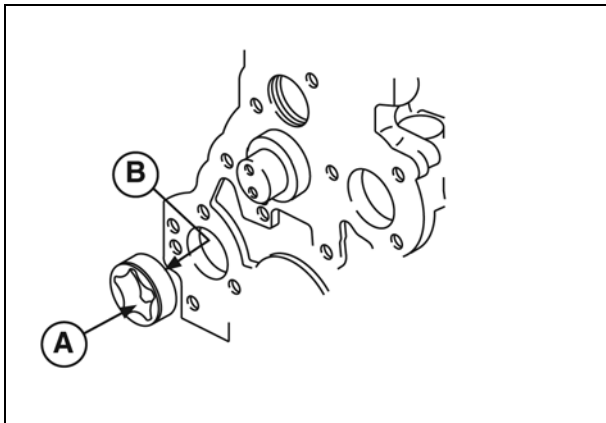

Figure 15

2. Install timing gear case with new gasket. Install camshaft retainer (**A**, Figure 16).

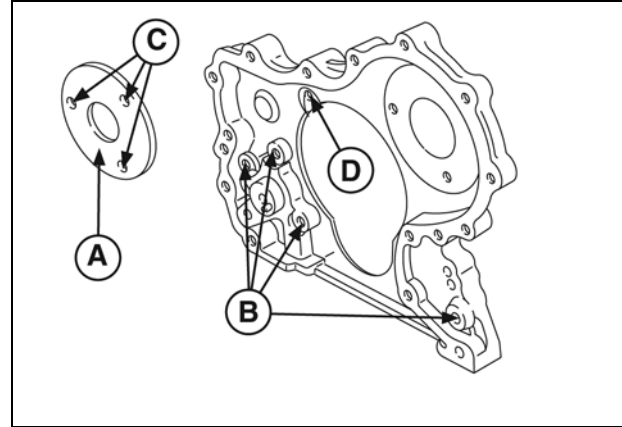

Figure 16

NOTE: It may be necessary to rotate oil pump drive to engage oil pump rotors.

NOTE: Position camshaft retainer so that the center hole does not interfere with the camshaft.

3. Note position, length, and number of screws (Figure 16).
 - M6 x 1.1 in. (M6 x 28 mm): 4 (**A**)
 - M6 x 0.7 in. (M6 x 18 mm): 3 (**B**)
 - M6 x 0.6 in. (M6 x 16 mm): 1 (**C**)
4. Torque screws to values listed in Section 14 - Engine Specifications.
5. Make sure crankshaft key is at the 12 o'clock position (**A**, Figure 17).

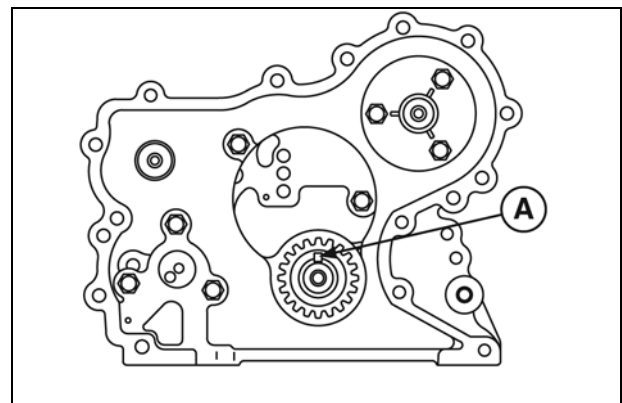

Figure 17

6. Assemble idler gear shaft with arrow up (**A**, Figure 18).

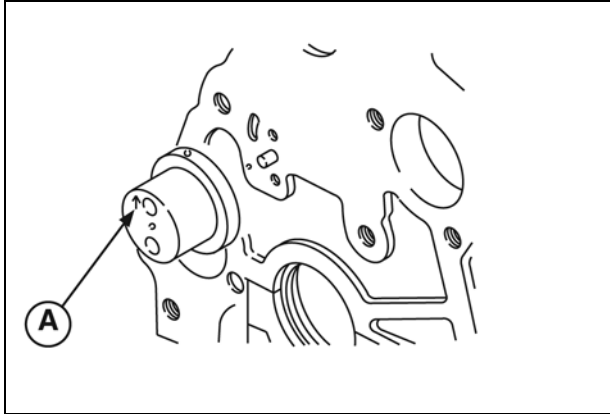

Figure 18

Engine models 430000 and 580000 built after date code 990111007 are equipped with right angle helical timing gears. Timing marks are identified by letters (**A**, **AA**, **B**, **BB**, etc.), instead of numbers. The timing procedure is the same.

7. With crankshaft key at the 12 o'clock position, assemble idler gear so that timing mark **11 (AA)** is aligned with timing mark **1 (A)** on crankshaft gear, timing mark **22 (BB)** is aligned with timing mark **2 (B)** on camshaft gear (Figure 19).

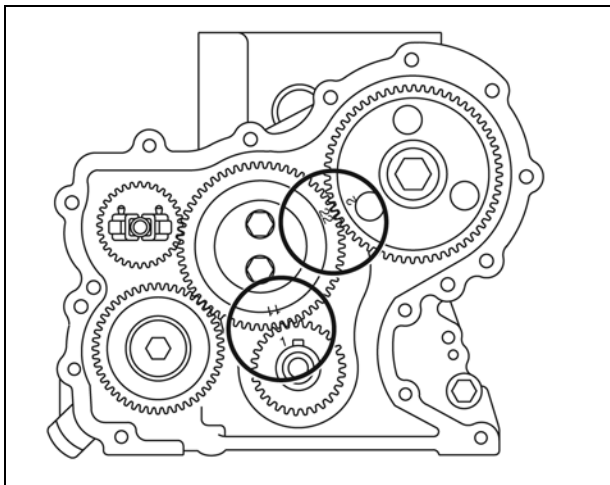

Figure 19

8. Install oil pump gear.
9. Torque screws to values listed in Section 14 - Engine Specifications. Camshaft gear (**A**, Figure 20), idler gear (**B**), and oil pump gear (**C**).

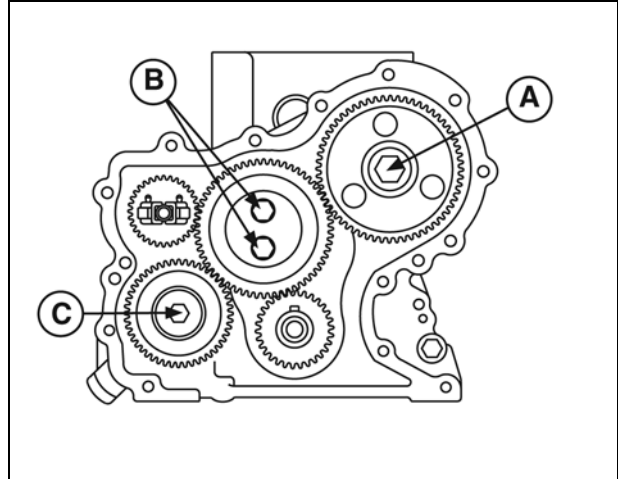

Figure 20

10. Install timing gear cover with new gasket. Note position, length, and number of screws (Figure 21). Torque screws to values listed in Section 14 - Engine Specifications.
 - M6 x 2.5 in. (M6 x 65 mm): 2 (**A**)
 - M6 x 2.1 in. (M6 x 55 mm): 3 (**B**)
 - M6 x 1.1 in. (M6 x 30 mm): 7 (**C**)
 - M6 Nut: 2 (**D**)

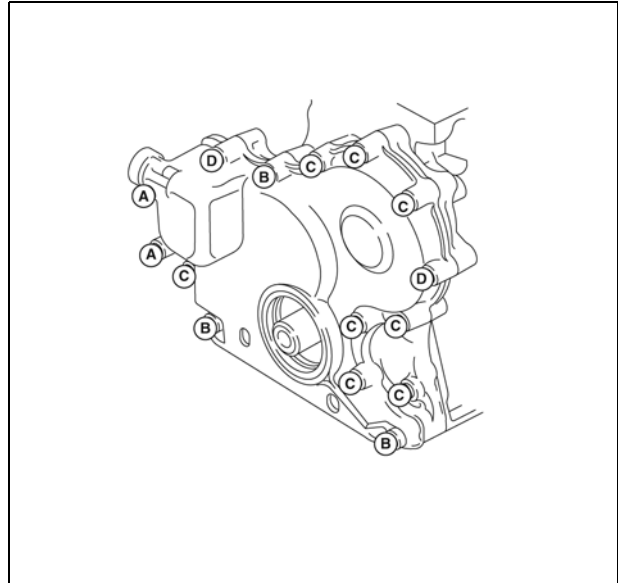

Figure 21

11. Install crankshaft pulley with timing mark at 12 o'clock position (No. 1 cylinder) (Figure 22).

NOTE: Ensure alignment pin in crankshaft gear is seated in hole in pulley.

12. Remove flywheel holder (A) and install trigger assembly and wire (B).

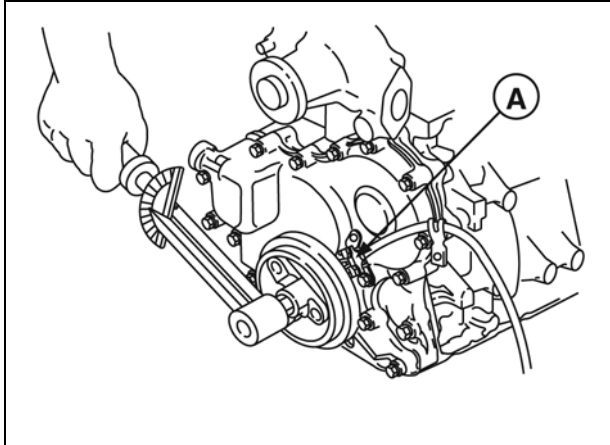

Figure 22

13. Install oil pick-up tube and strainer with new gasket.
 14. Apply a small bead of Permatex® No. 2 or other similar sealant (A, Figure 23).

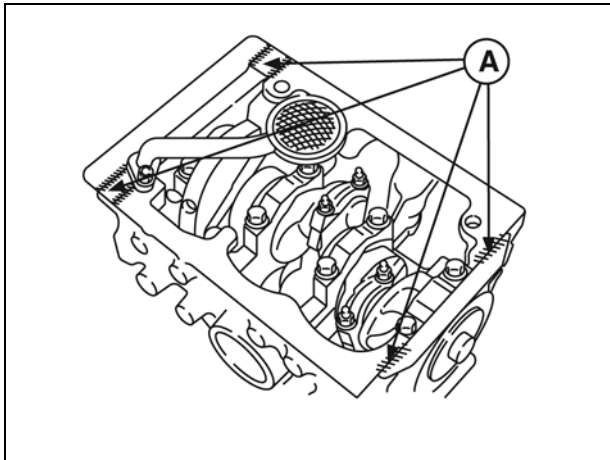

Figure 23

15. Install oil pan with new gasket. Torque screws and nuts to values shown in Section 14 - Engine Specifications.
 16. Install V-belt and fan (if equipped).
 17. Install governor lever (A, Figure 24) on to governor shaft. Do not tighten governor nut at this time.
 18. Install governor link with spring (B).

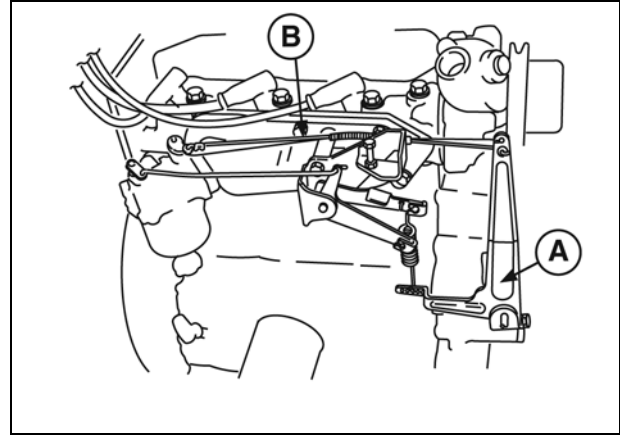

Figure 24

19. Insert governor spring into original hole in governor lever.

NOTICE: Governor spring must be installed in correct hole in governor control lever by engine model (Figure 25).

- Model 430400 - Top Hole (A)
- Model 580400 - Bottom Hole (B)

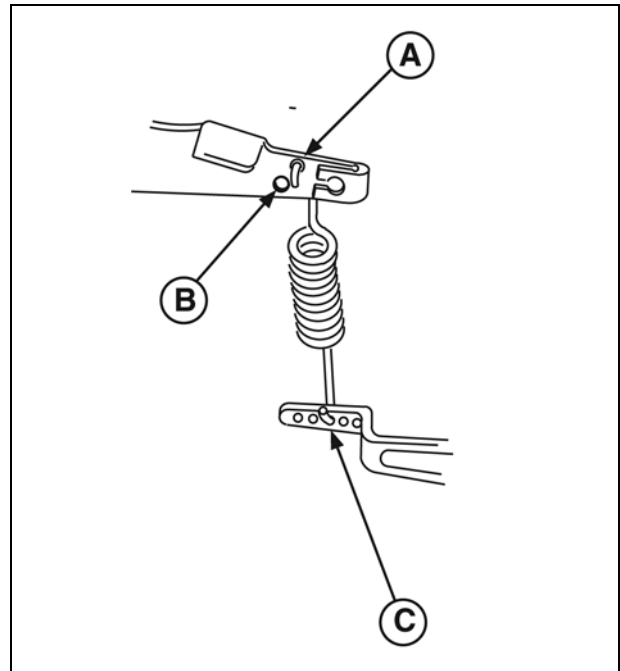

Figure 25

Adjust Governor

1. Move governor control lever (**A**, Figure 26) up to end of travel and hold in this position (throttle wide open).
2. Rotate governor shaft (**B**) clockwise to end of travel.
3. Torque governor nut (**C**) to value listed in Section 14 - Engine Specifications.

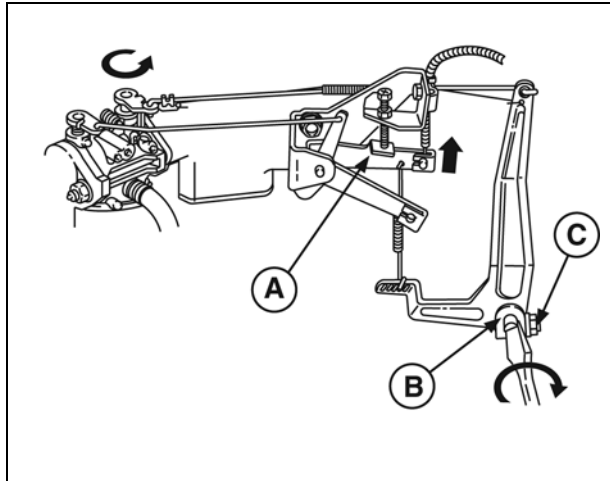

Figure 26

Troubleshooting

If engine hunts at top no load speed, check governor adjustment as follows:

1. Stop engine.
2. Move equipment control to "FAST" position.
3. Disconnect governor link spring and link.
4. Rotate throttle wide open position.

NOTE: Position of governor link must be within 1 mm of center of hole in throttle (Figure 27).

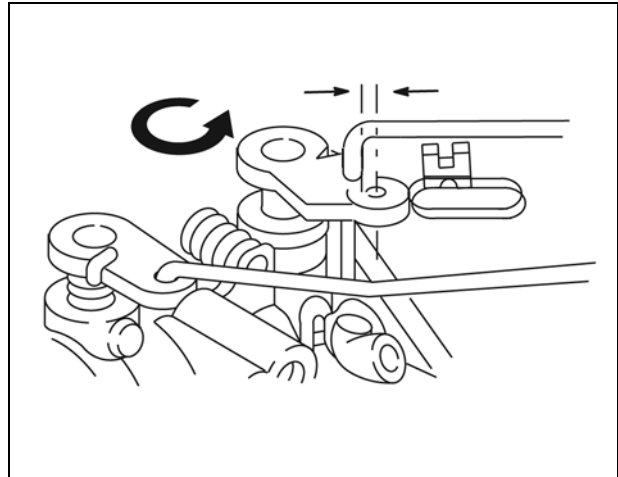

Figure 27

- If dimension is greater than 1 mm, perform governor adjustment.
- If engine continues to hunt at top no load speed, decrease governor sensitivity by moving governor spring to next hole on governor lever (Figure 28).

NOTE: Moving spring away from governor shaft pivot point **decreases** sensitivity. Moving spring towards governor shaft pivot point **increases** sensitivity.

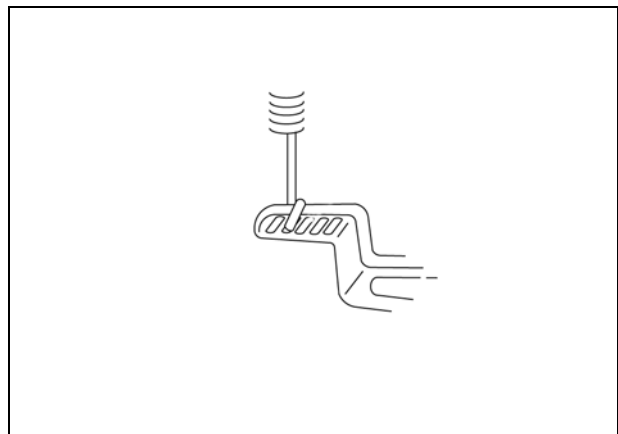

Figure 28

Electronic Governor

The ignition module and related wiring for the electronic governor is supplied by the equipment manufacturer.

NOTE: Engines equipped with an electronic governor do not have mechanical governor components.

3

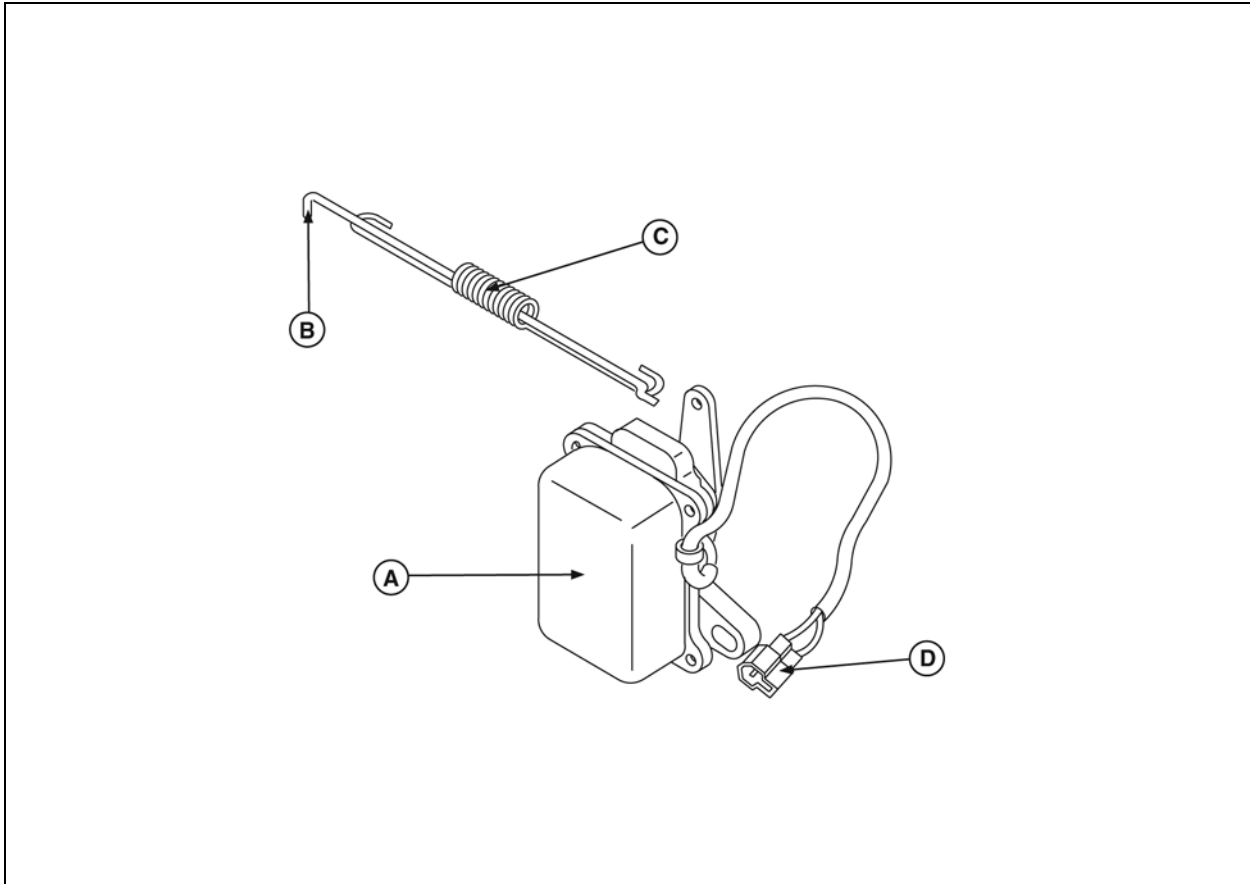

- A - Governor Actuator
- B - Governor Link
- C - Governor Link Spring
- D - Wiring Harness

Inspect Governor Actuator

1. Disconnect harness at connector (A, Figure 29).
2. Touch test leads (B) to terminals of a known good 12 volt battery.
 - Actuator lever (C) should quickly move the throttle to a wide open position (D).
3. Remove test leads from battery terminals.
 - Actuator lever should quickly move throttle lever to idler position.
4. Replace actuator if not to specification.

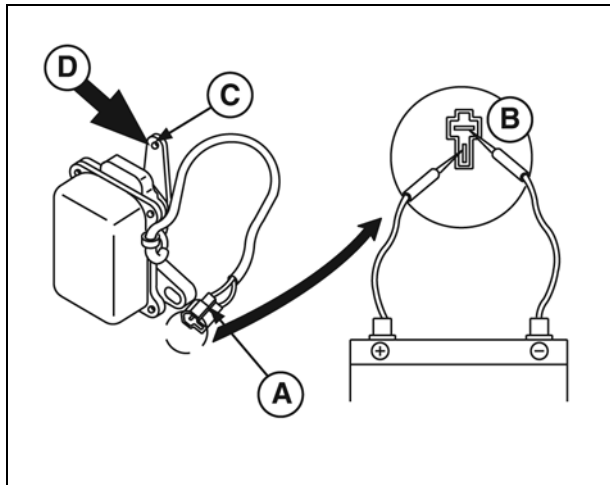

Figure 29

Remove Governor Actuator

1. Disconnect governor link spring and link (A, Figure 30).
2. Remove two screws (B) and actuator (C).

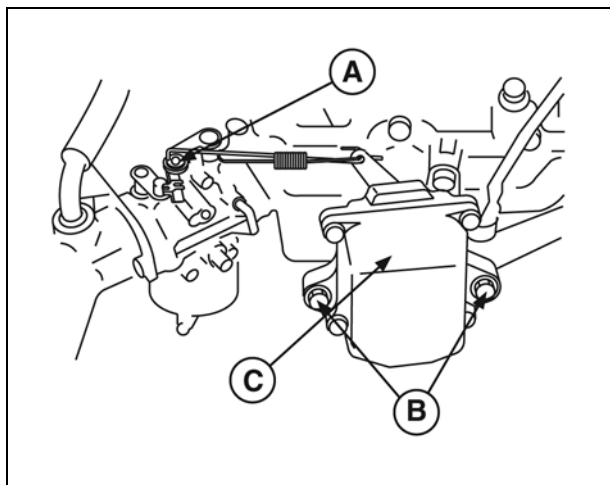

Figure 30

Install Governor Actuator

1. Assemble governor link spring and link to actuator lever (Figure 31).

NOTE: Open ends of spring must face cylinder head.

2. Assemble actuator to mounting bracket loosely. Do not tighten screws.

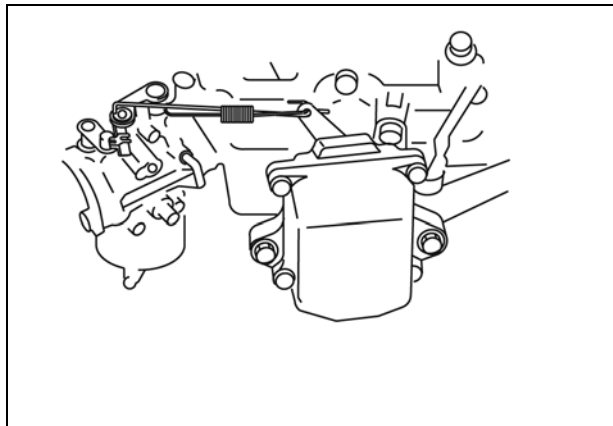

Figure 31

3. Rotate throttle lever clockwise to end of travel and hold in this position.
4. Slide actuator until governor link is positioned slightly to rear of hole in throttle lever bushing (Figure 32).
5. Torque mounting screws to values listed in Section 14 - Engine Specifications.
6. Assemble governor link and spring to throttle lever.

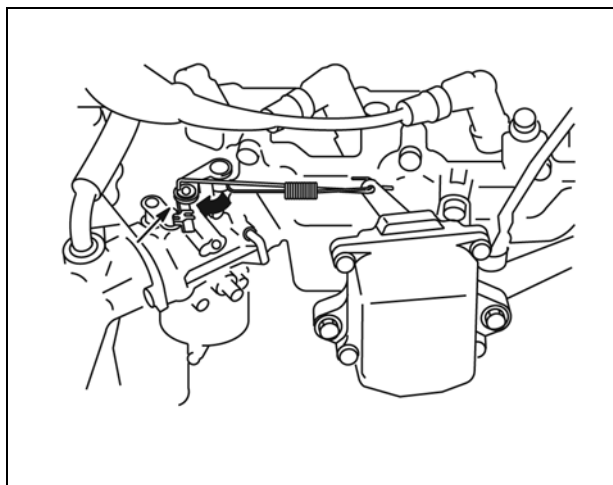

Figure 32

SECTION 4 - FLYWHEEL AND REAR SEAL RETAINER

REMOVE OIL PAN AND FLYWHEEL-----	36
REMOVE REAR SEAL RETAINER -----	36
REPLACE OIL SEAL -----	36
INSTALL REAL SEAL RETAINER AND FLYWHEEL -----	37
INSTALL OIL PAN -----	37

Removing Pan and Flywheel

1. Drain oil from engine.
2. Remove oil pan screws and nuts (Figure 1).
3. Remove oil pan and discard gasket.

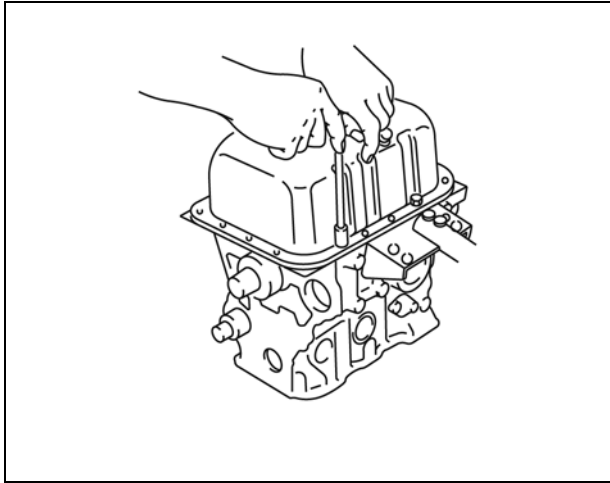

Figure 1

4. Install Flywheel Holder #19418 (A, Figure 2). Remove flywheel screws and flywheel.

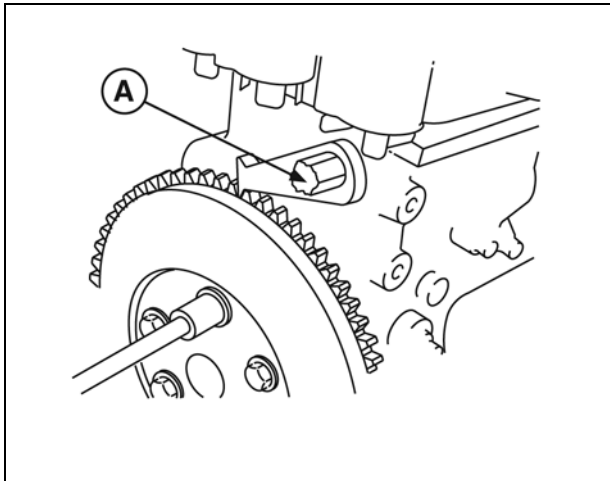

Figure 2

5. Inspect flywheel for cracks or damage. Inspect flywheel ring gear for worn, chipped, or cracked teeth.

NOTE: If ring gear is worn or damaged, the flywheel must be replaced.

Remove Rear Seal Retainer

1. Remove rear seal retainer and discard gasket (Figure 3).

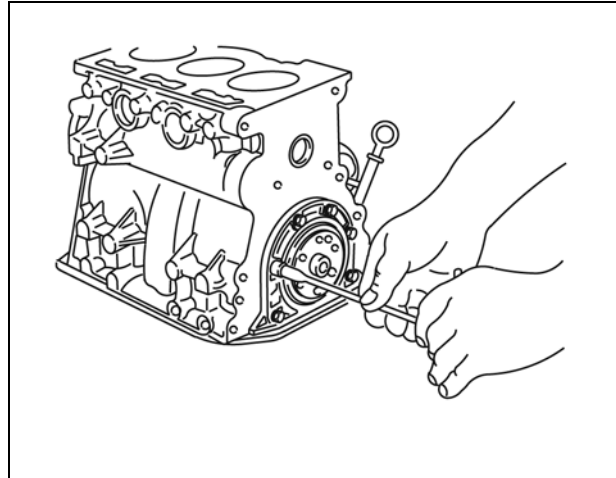

Figure 3

Replacing Oil Seal

1. Remove oil seal (Figure 4).

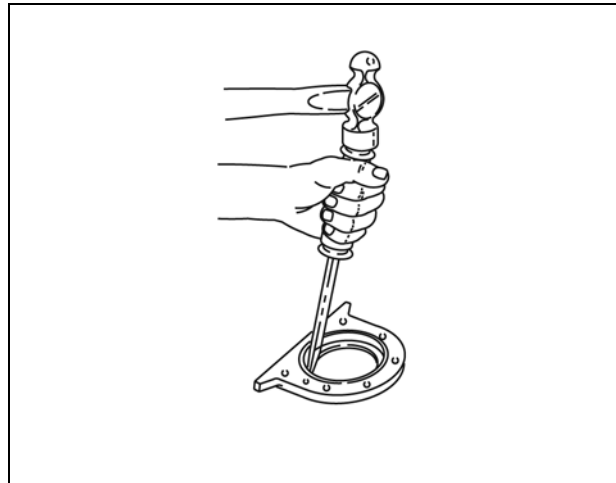

Figure 4

2. Lubricate outside diameter of oil seal.
3. Using a Seal Driver #19424, install new seal (Figure 5).

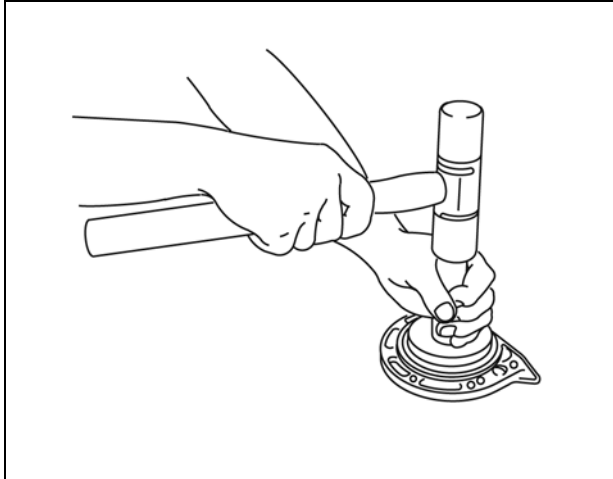

Figure 5

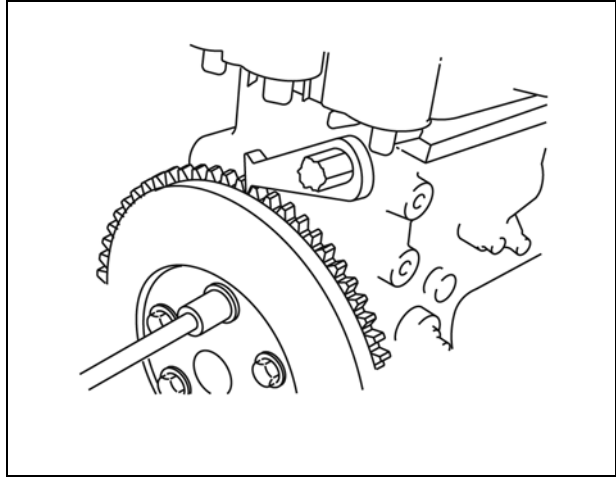

Figure 7

Installing Rear Seal Retainer and Flywheel

1. Install rear seal retainer with new gasket (Figure 6). Torque screws to values listed in Section 14 - Engine Specifications.

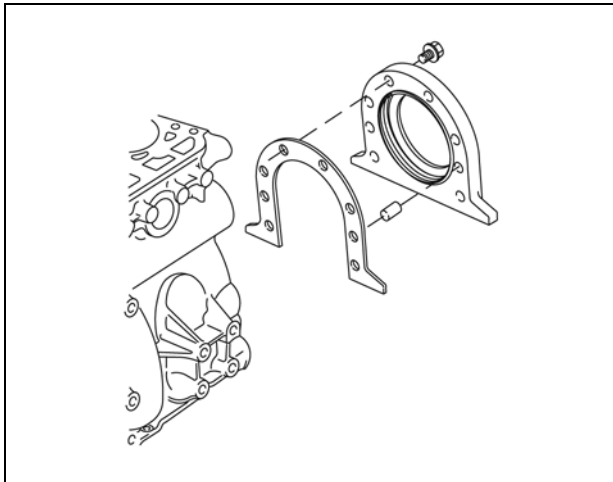

Figure 6

2. Install flywheel (Figure 7).

NOTE: Apply Permatex® No. 2 or similar sealant to flywheel screws.

3. Torque flywheel screws to values listed in Section 14 - Engine Specifications.
4. Remove flywheel holder.

Install Oil Pan

1. Install oil pan with new gasket.
2. All small bead of Permatex® No. 2 or similar sealant to crankcase areas (A, Figure 8).

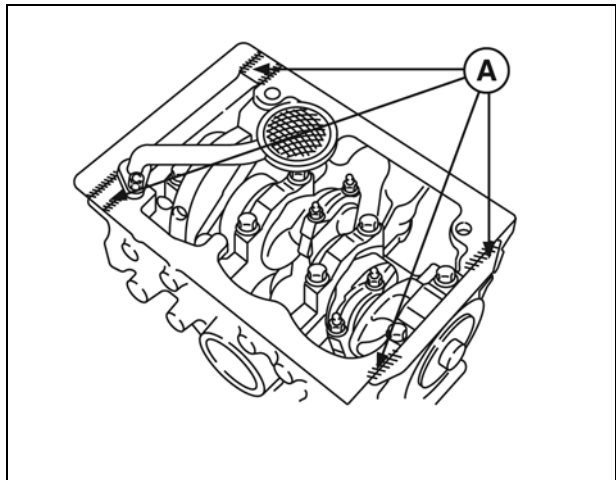
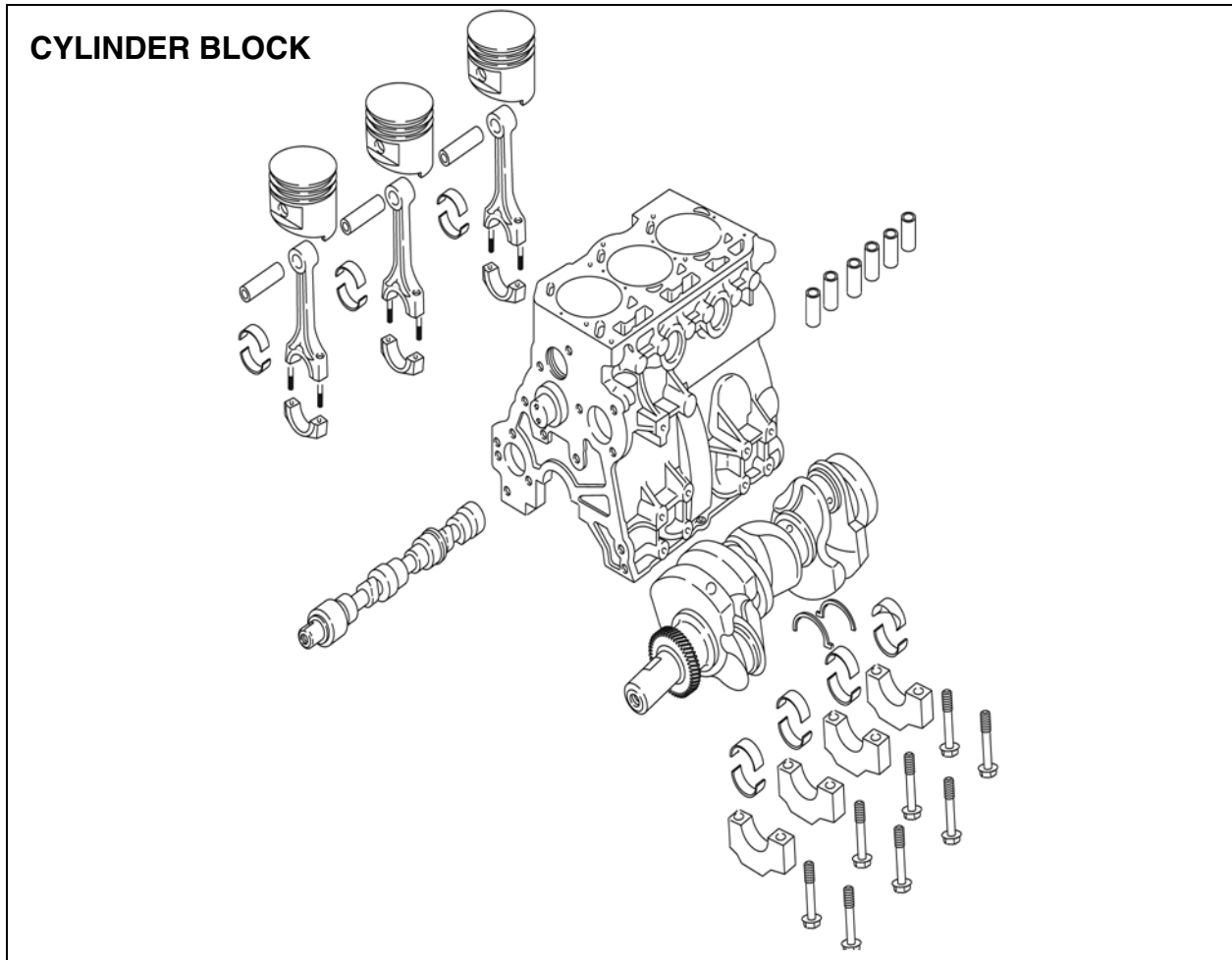

Figure 8

3. Torque screws and nuts to values listed in Section 14 - Engine Specifications.

SECTION 5 - CYLINDER BLOCK DISASSEMBLY

CYLINDER BLOCK DISASSEMBLY -----40



Cylinder Block Disassembly

An automotive type engine stand is recommended when complete engine disassembly is required. See drawings below for dimensions to make an engine stand mounting fixture. The engine stand shown below is manufactured by Snap-On®.

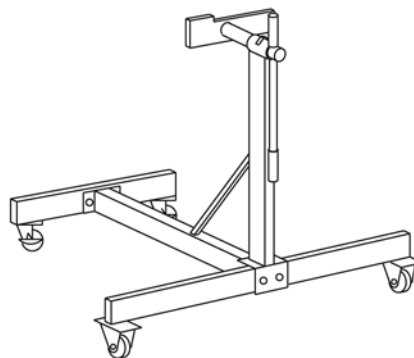
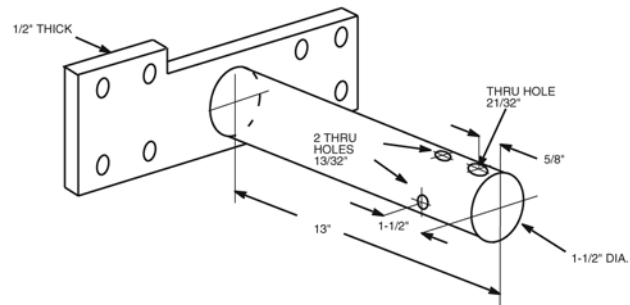
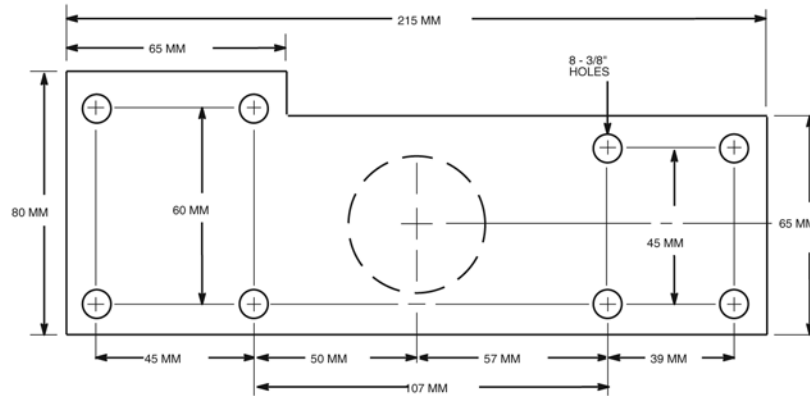

1. Remove cylinder head. See Section 2.
2. Remove oil pan, timing cover, gears, and case. See Section 3.
3. Remove flywheel and rear seal retainer. See Section 4.
4. Remove starter motor (Figure 1).

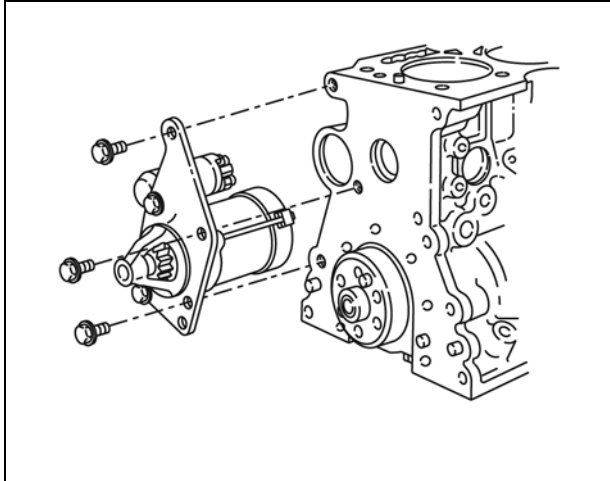

Figure 1

5. Remove alternator bracket and alternator (Figure 2).

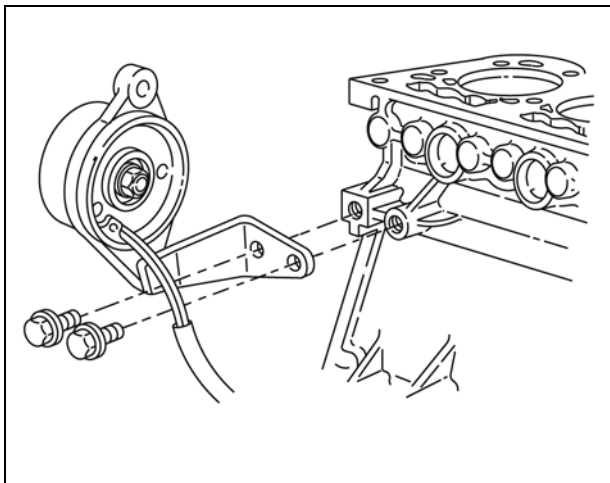

Figure 2

6. Remove valve lifters (Figure 3).

NOTE: Number lifters so that they may be reinstalled in the same position.

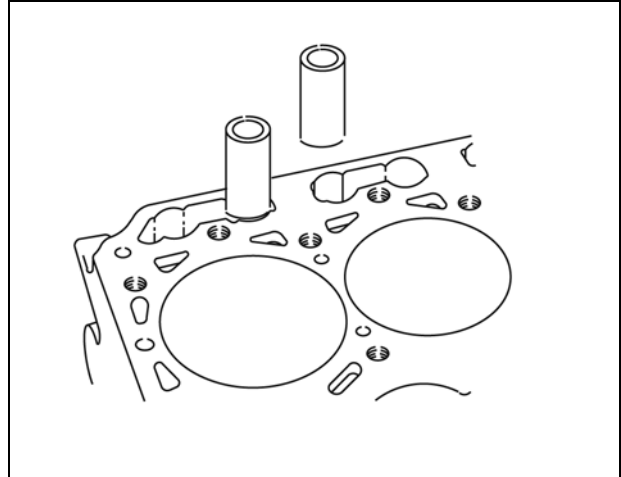

Figure 3

7. Remove camshaft (Figure 4).

NOTE: Use care when removing camshaft to prevent damaging cam bearing, journals, and lobes.

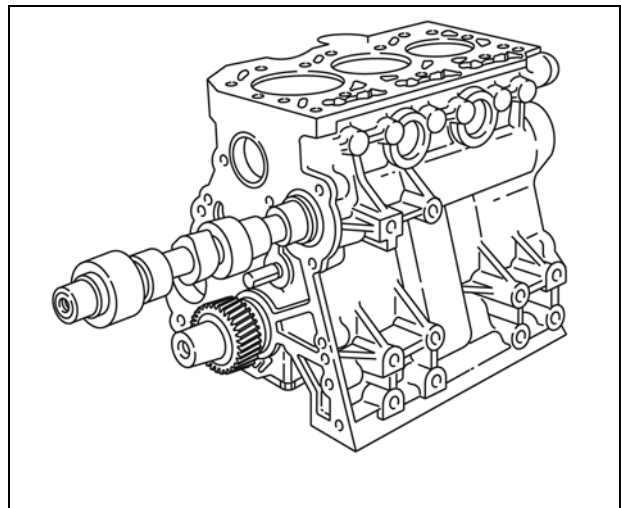

Figure 4

8. Remove oil pick-up tube and strainer (Figure 5). Discard gasket.

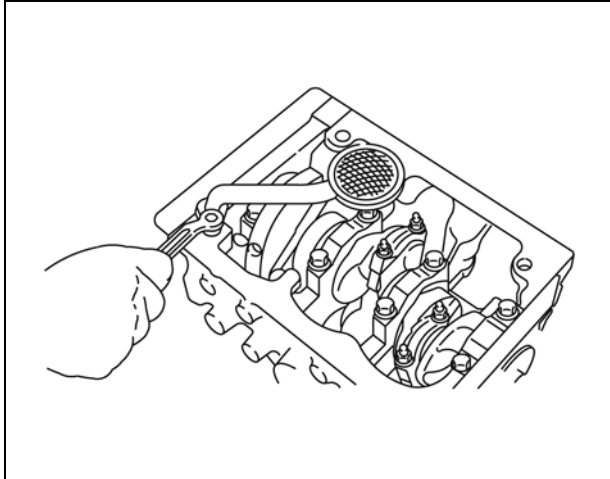

Figure 5

9. Remove connecting rod and piston assemblies (Figure 6).

NOTE: Remove carbon or ridge from cylinder and number connecting rod/piston assemblies before removing from cylinders.

- Remove connecting rod cap with lower bearing.
- Push connecting rod and piston out through top of cylinder.
- Reassemble connecting rod cap to connecting rod to prevent interchanging components.

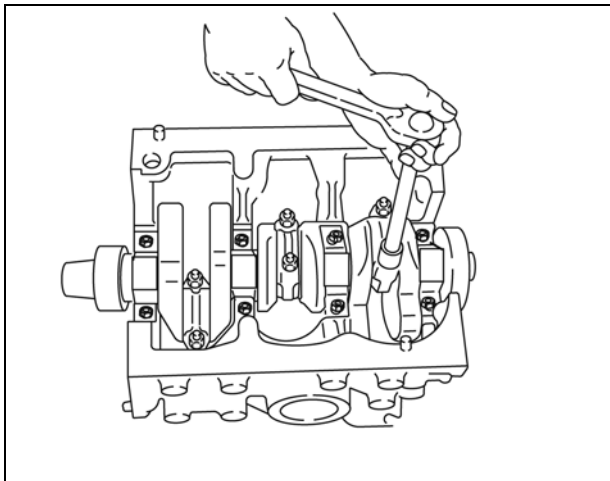

Figure 6

10. Remove crankshaft main bearing caps, keeping main bearings with their respective caps (Figure 7).

NOTE: Main bearing caps are numbered 1 through 4.

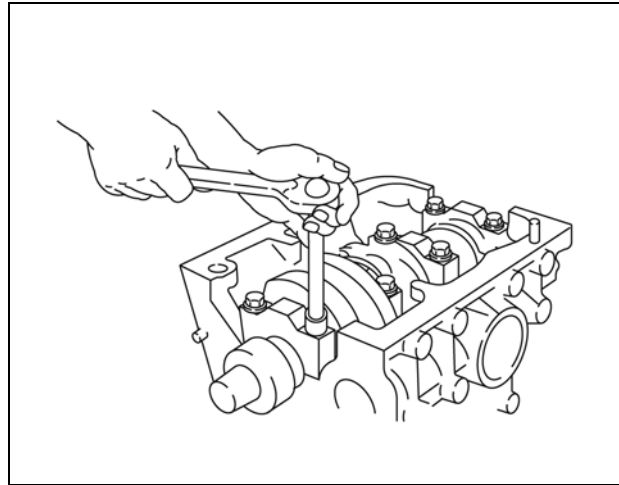

Figure 7

11. Remove crankshaft (A, Figure 8).

- Remove crankshaft thrust washers (#3 main bearing).
- Remove upper main bearings from saddles and place with respective bearing caps.

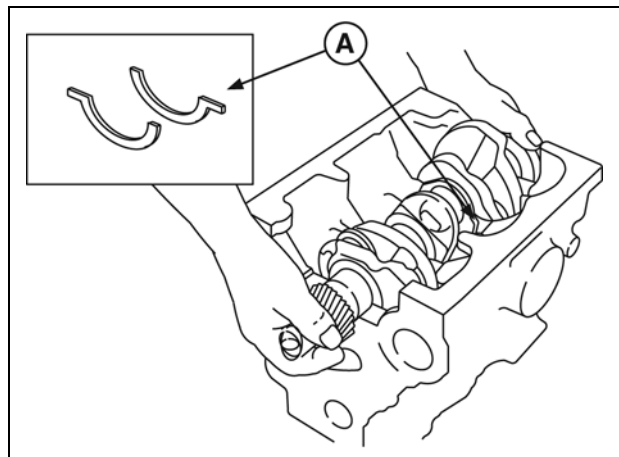

Figure 8

SECTION 6 - CYLINDER BLOCK INSPECTION AND REPAIR

CHECK CYLINDER BLOCK	44
CHECK CYLINDER BORE FOR WEAR	44
REPLACE CAMSHAFT BEARINGS	45
REPLACE CAMSHAFT PLUG	45

Inspect Cylinder Block

1. Remove all traces of sealant and gasket material from mounting surfaces. Inspect cylinder block for damage, cracks, and stripped threads.
2. Inspect cylinder block deck for distortion (Figure 1).
 - Distortion Limit - 0.003 in. (0.08 mm).

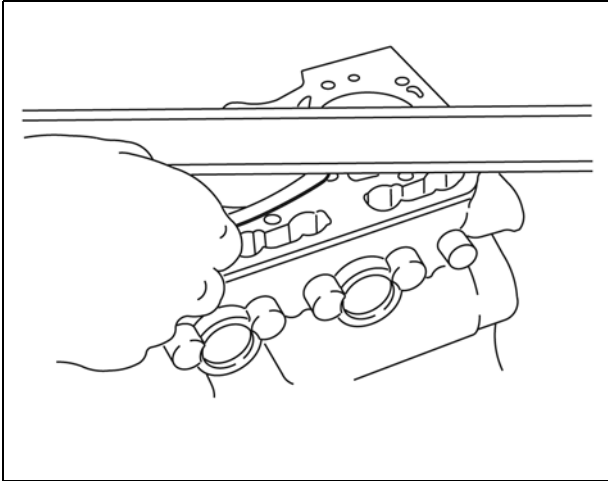

Figure 1

3. If cylinder block exceeds limits shown, it may be resurfaced (Figure 2).

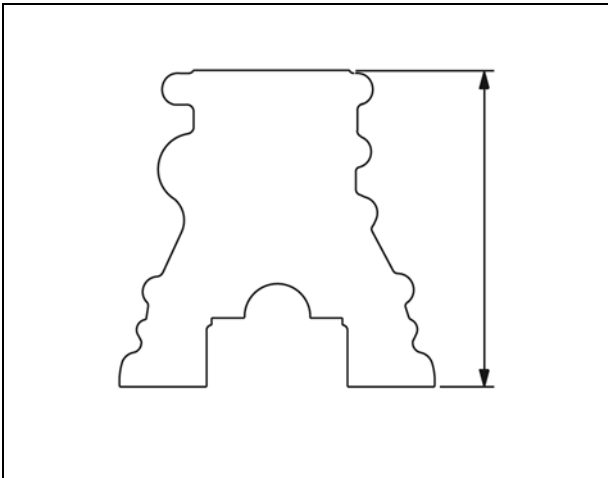

Figure 2

Inspect Cylinder Bore for Wear:

1. Measure cylinder bore in 6 points at right angles (Figure 3).
2. If cylinder bore is worn more than 0.003 in. (0.075 mm) or more than 0.0015 in. (0.035 mm) out of round, it must be resized.

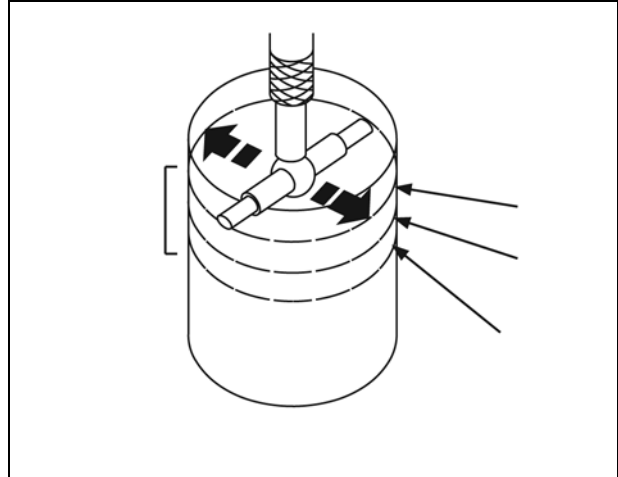

Figure 3

NOTE: Always resize to exactly 0.010 in. (0.25mm) over standard bore size. If this is done accurately, the service oversize rings and pistons will fit perfectly and proper clearances will be maintained.

3. Check valve lifter bore (Figure 4).
 - Standard Dimension - 0.709 in. (18.02 mm)
 - Reject Dimension - 0.711 in. (18.05 mm)
4. Check valve lifter (Figure 4).
 - Standard Dimension - 0.708 in. (17.98 mm)
 - Reject Dimension - 0.705 in. (17.91 mm)

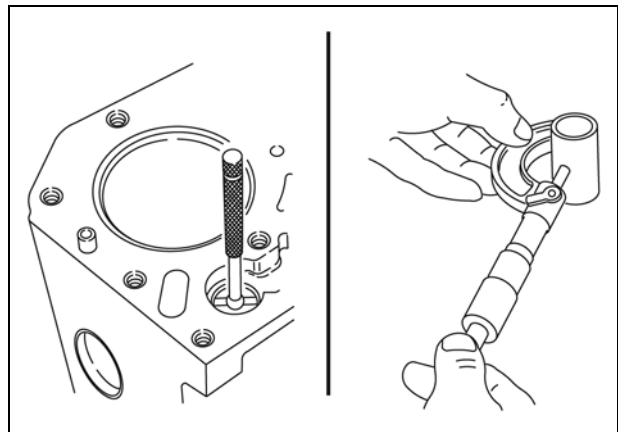

Figure 4

5. Check Camshaft bearing (Figure 5).
 - Replace if greater than 1.42 in. (36.06 mm)

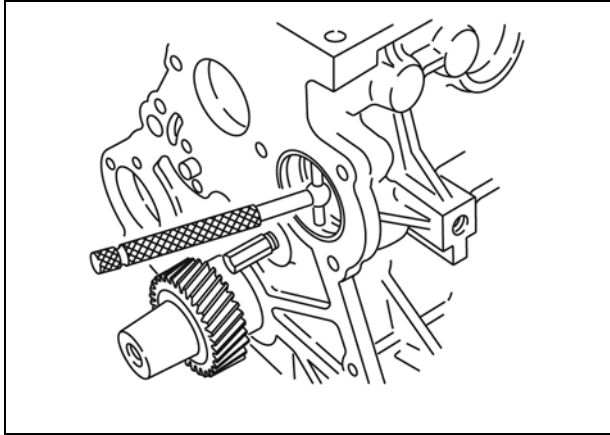

Figure 5

Replace Camshaft Bearing

1. Using Camshaft Bearing Puller #19421, remove camshaft bearing (Figure 6).

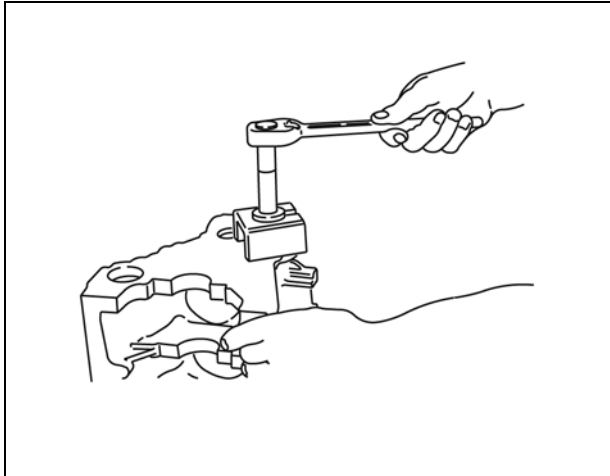

Figure 6

2. Using Camshaft Bearing Driver #19422, install camshaft bearing (Figure 7).

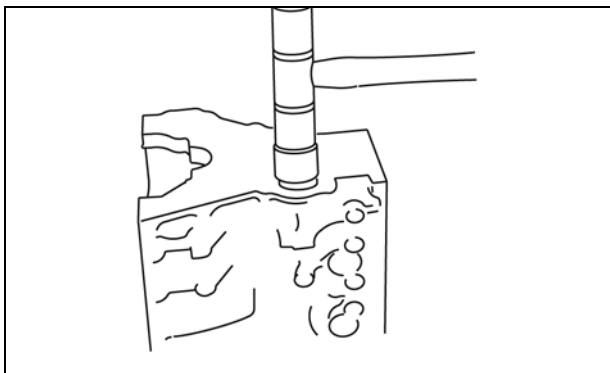

Figure 7

Replace Camshaft Plug

1. Remove rear camshaft plug (Figure 8).

NOTICE: Use a wood dowel or brass rod to prevent damage to the camshaft bearing.

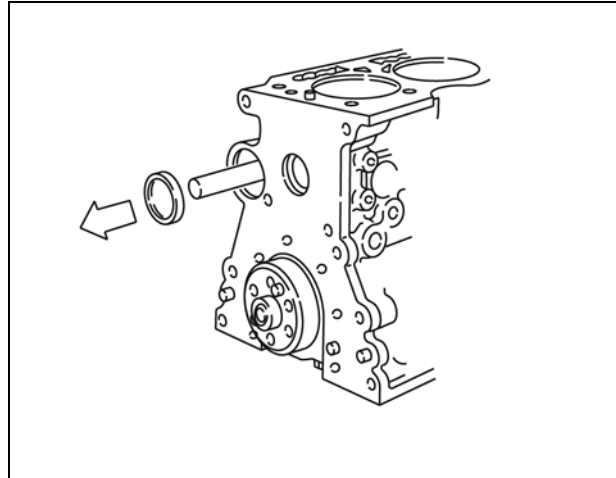

Figure 8

2. Using Camshaft Bearing Driver #19422, install new camshaft plug flush with cylinder block (Figure 9).

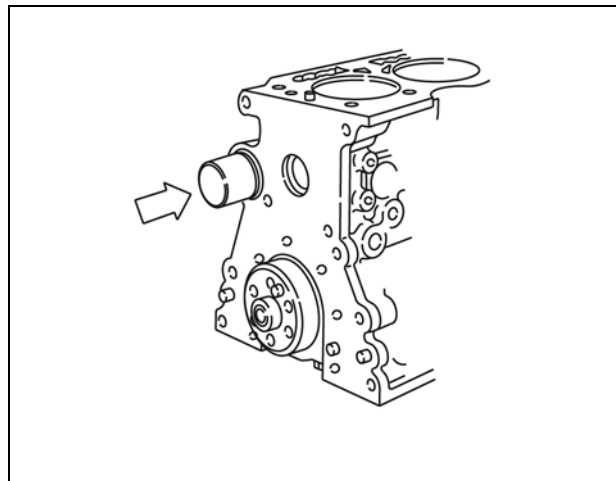

Figure 9

NOTE: If cylinder block is being resized, the following parts should be removed so that the cylinder block can be thoroughly cleaned.

3. Remove oil pressure switch (A, Figure 10), water gallery plug (B), and oil filter adapter (C).

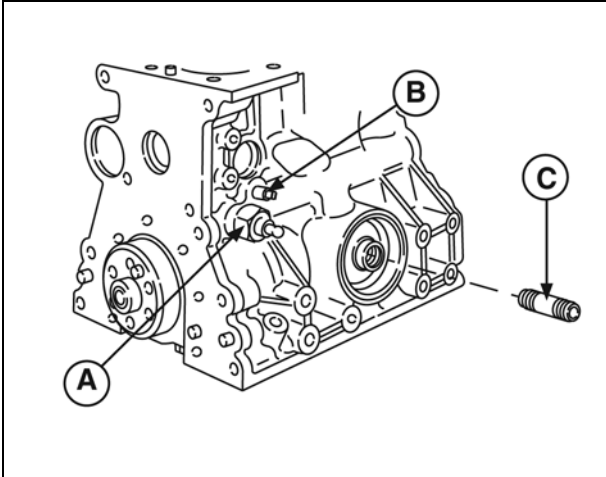

Figure 10

4. Remove timing gear oil nozzle (A, Figure 11).

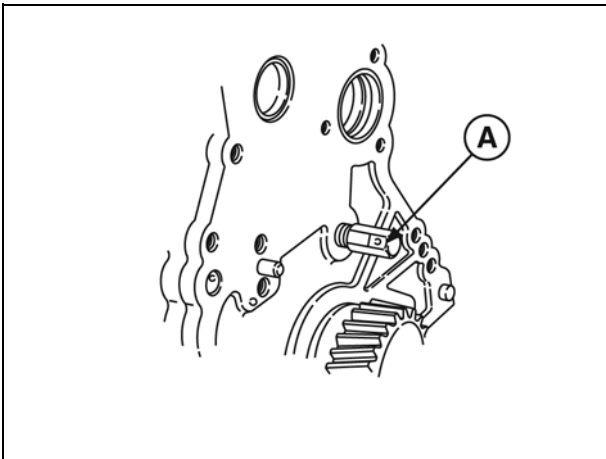

Figure 11

5. When reinstalling oil nozzle, oil hole must be positioned at a 45° angle, pointing towards the idler gear (A, Figure 12).

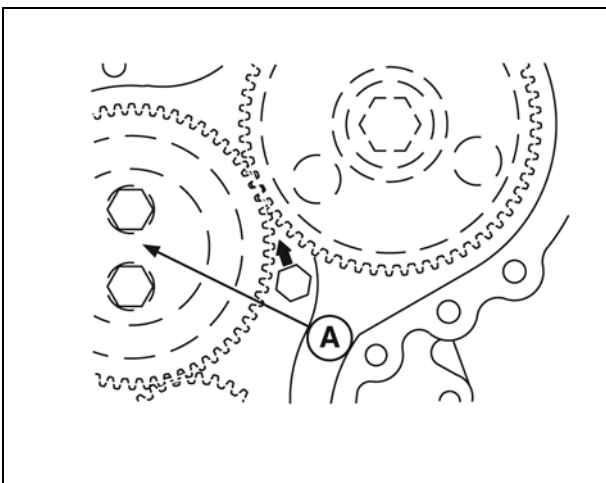

Figure 12

SECTION 7 - CRANKSHAFT, CAMSHAFT AND BEARINGS

INSPECT CRANKSHAFT	48
CHECK MAIN BEARING CLEARANCES	49
CHECK CONNECTING ROD BEARING CLEARANCES	50
CHECK CRANKSHAFT END PLAY	50
INSPECT CAMSHAFT	51

Inspect Crankshaft

1. Inspect crankshaft journals for grooves or signs of scoring. If found, crankshaft must be re-ground or replaced.
2. Check the main bearing and crankpin journals for wear and taper (Figure 1).

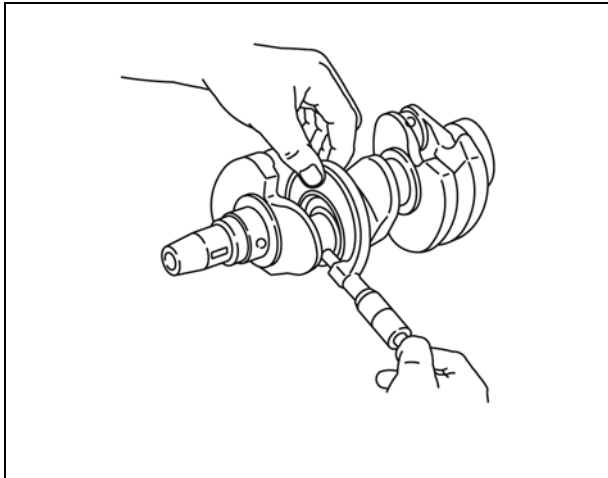

Figure 1

- Standard Size (Main) - 1.6525 - 1.6535 in. (41.976 - 42.000 mm)
- Standard Size (Crankpin) - 1.4557 - 1.4567 in. (36.976 - 37.000 mm)
- Maximum out of round and taper - 0.0008 in. (0.02 mm)

3. If crankshaft journals are not within specification, the crankshaft may be re-ground and 0.010 in. (0.25 mm) undersize bearings installed. See illustrated parts list for part numbers.
4. Check the crankshaft for run-out at #3 main bearing journal (Figure 2).

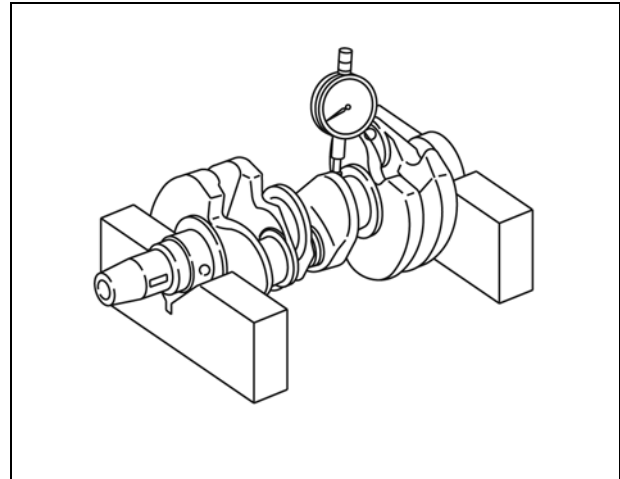

Figure 2

- Maximum Run-out - 0.0023 in. (0.06 mm)

NOTE: If run-out exceeds specification shown, the crankshaft must be replaced.

5. Check crankshaft timing gear teeth for damage (Figure 3). If timing gear teeth are damaged or worn, the crankshaft must be replaced.

NOTE: See Section 3 for procedure to check crankshaft timing gear for wear.

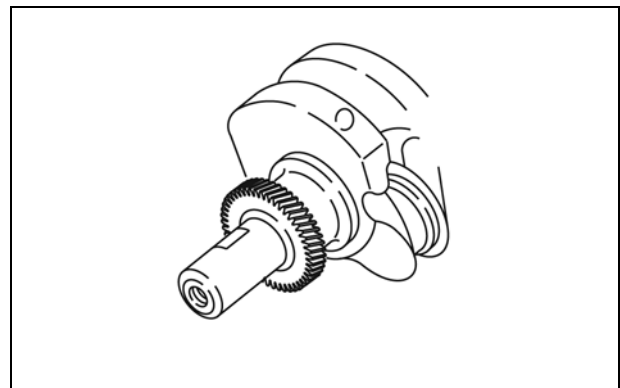

Figure 3

Check Main Bearing Clearances

NOTE: If main bearings show signs of flaking or scoring, bearings must be replaced.

NOTE: Main bearing saddles in cylinder block, main bearing caps, main bearings, and crankshaft journals must be clean and free of oil.

1. With upper main bearings installed, install crankshaft.
2. Lay a strip of plastigage lengthwise on journal (A, Figure 4).

NOTE: Do not lay plastigage across hole in crankshaft journal.

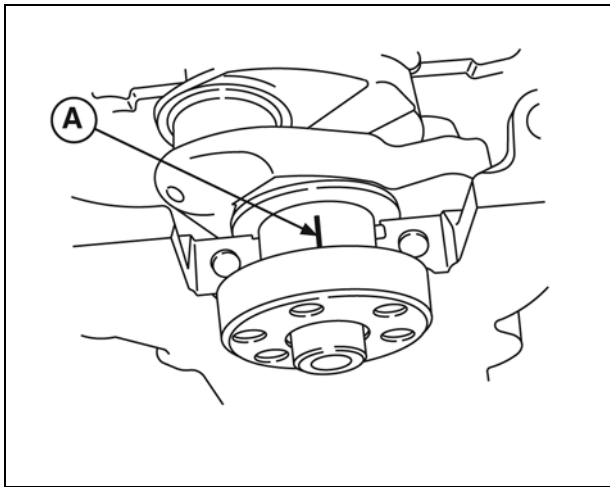

Figure 4

3. Assemble main bearing cap with bearing (Figure 5) and torque to values listed in Section 14 - Engine Specifications.

NOTE: Do not allow crankshaft to rotate.

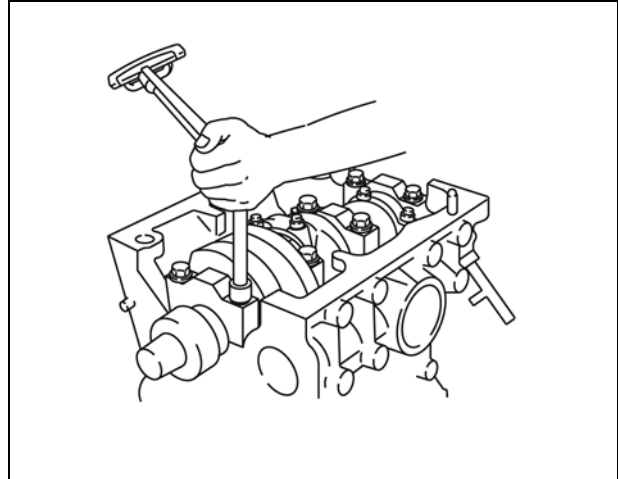

Figure 5

4. Remove the bearing cap. Measure the plastigage at its widest point (A, Figure 6). If the clearance is not within specification, replace the bearings.

- Standard Main Bearing Clearance - 0.0008 - 0.0017 in. (0.020 - 0.044 mm)
- Reject Main Bearing Clearance - 0.0028 in. (0.07 mm)

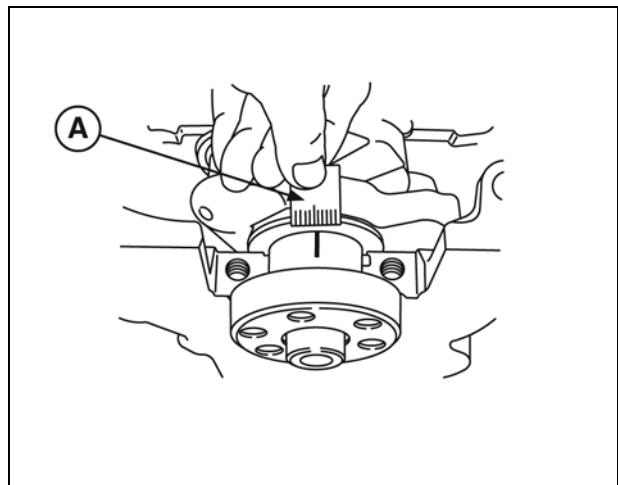

Figure 6

5. Repeat procedure for each main bearing.

Check Connecting Rod Bearing Clearances

NOTE: If connecting rod bearings show signs of flaking or scoring, bearings must be replaced.

NOTE: Connecting rod bearings and crankpin journals must be clean and free of oil.

1. With upper bearing assembled to the connecting rod, install the connecting rod.
2. Lay a strip of plastigage lengthwise on journal (A, Figure 7).

NOTE: Do not lay plastigage across hole in crankshaft journal.

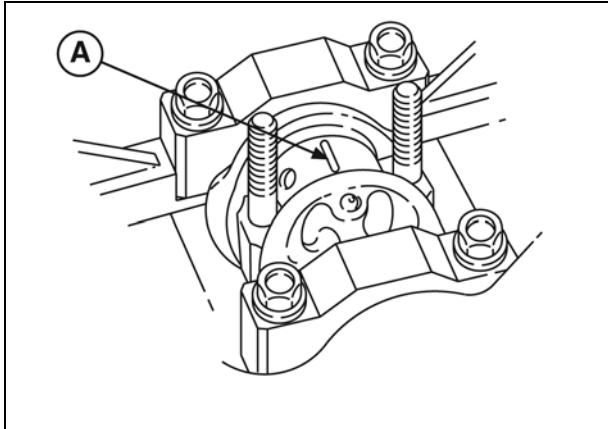

Figure 7

3. Assemble connecting rod cap with bearing and torque to values listed in Section 14 (Figure 8).

NOTE: Do not allow crankshaft to rotate.

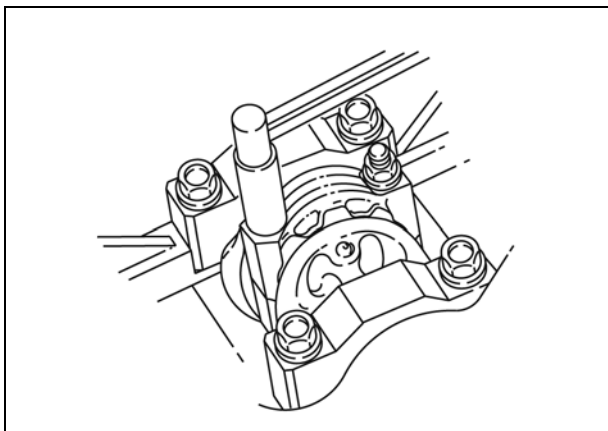

Figure 8

4. Remove the connecting rod cap. Measure the plastigage at its widest point (A, Figure 9). If the clearance is not within specification, replace the bearings.

- Standard Main Bearing Clearance - 0.0008 - 0.0017 in. (0.020 - 0.044 mm)
- Reject Main Bearing Clearance - 0.0028 in. (0.07 mm)

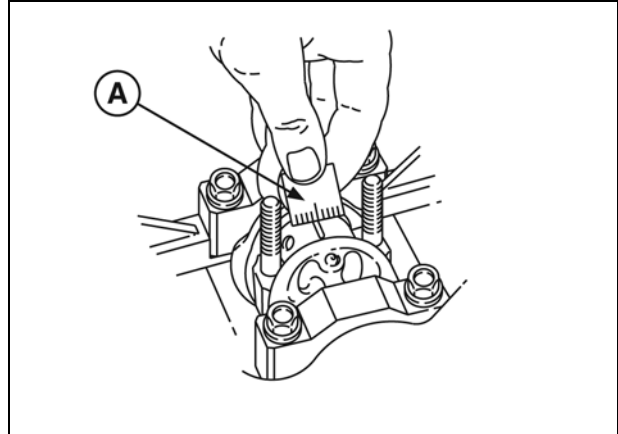

Figure 9

5. Repeat procedure for each main bearing.

Check Crankshaft End Play

1. With thrust washers installed, check crankshaft end play at #3 main bearing (Figure 10).
 - Standard Crankshaft End Play - 0.0008 - 0.009 in. (0.020 - 0.23 mm)
 - Limit Crankshaft End Play - 0.012 in. (0.30 mm)
2. If end play exceeds limit, 0.005 in. (0.13 mm), over size thrust washers are available. See illustrated parts list for part numbers.

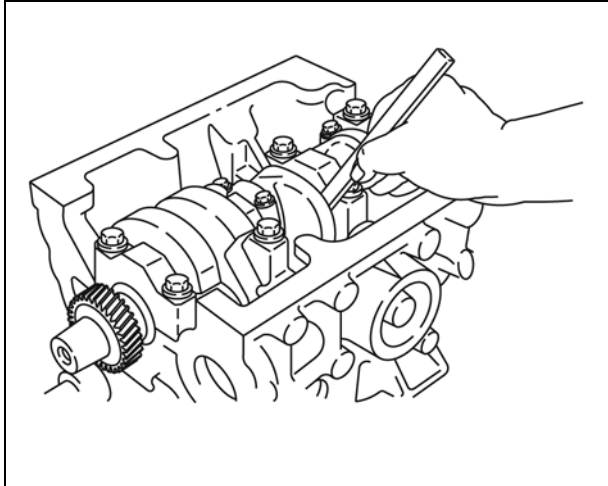

Figure 10

Inspect Camshaft

1. Measure camshaft lobe height (Figure 11). If lobes are not to specification, replace the camshaft.
 - Standard Intake/Exhaust - 1.183 - 1.186 in. (30.065 - 30.135 mm)
 - Reject Intake/Exhaust - 1.179 in. (29.965 mm)

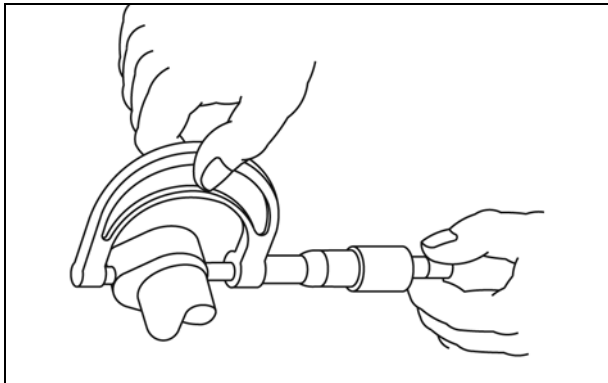

Figure 11

2. Measure camshaft journals (Figure 12).

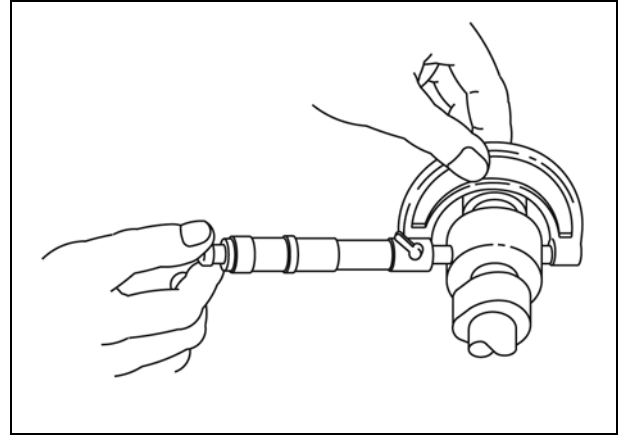

Figure 12

3. Measure camshaft run-out (Figure 13).
 - Maximum Run-out - 0.0012 in. (0.03 mm)
4. If a run-out exceeds specification, the camshaft must be replaced.

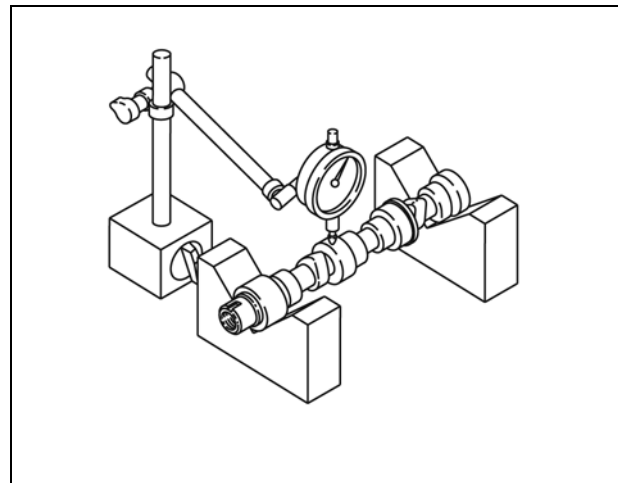

Figure 13

SECTION 8 - PISTON, RINGS AND CONNECTING ROD

DISASSEMBLE PISTON AND CONNECTING ROD	54
INSPECT PISTONS AND RINGS	54
CHECK PISTON PIN AND CONNECTING ROD	55
ASSEMBLE PISTON AND CONNECTING ROD	56
ASSEMBLE PISTON RINGS TO PISTON	56

Disassemble Piston and Connecting Rod

1. Remove compression rings using Ring Expander #19340 (Figure 1).

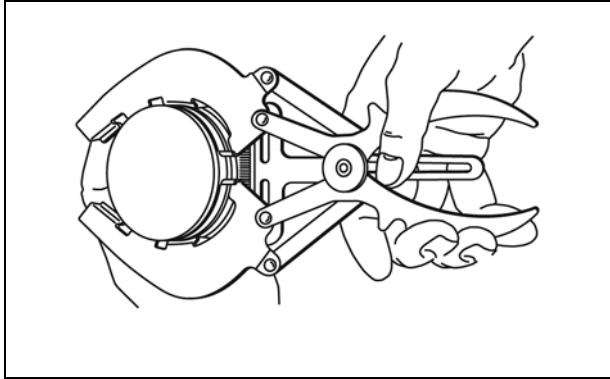

Figure 1

2. Oil ring may be removed by hand by spiraling top scraper into center ring groove, then into top groove and off piston. Repeat for bottom scraper, then remove expander.
3. Disassemble piston from connecting rod using Piston Pin Fixture #19419.

NOTE: Piston pin stop (A, Figure 2) must be removed from support (B) when disassembling piston and connecting rod.

4. Insert threaded driver (C) through piston pin from FRONT side of piston and thread into pilot.
5. Place piston with driver onto support with arrow on piston facing up.
6. Press out piston pin.

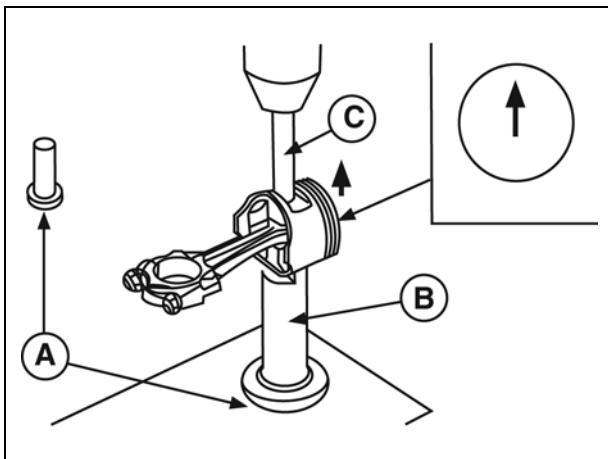

Figure 2

If the cylinder bore is to be resized there is no reason to check the piston as a new oversized piston will be used.

If the cylinder is not going to be resized, and the piston shows no signs of scoring, the piston should be checked.

1. Check side clearance of ring grooves using NEW rings (A, Figure 3). If a 0.0045 in. (0.11 mm) feeler gauge can be inserted, the ring groove is worn. The piston must be replaced.

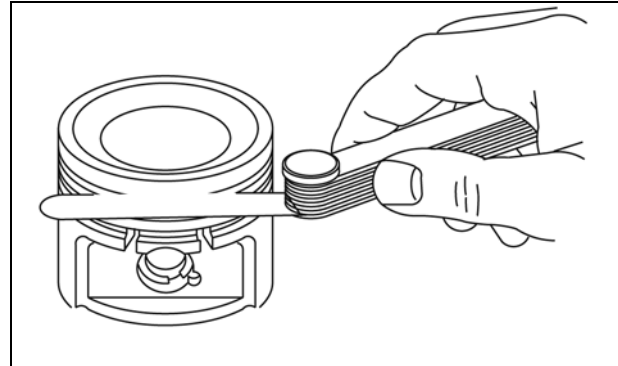

Figure 3

2. Check ring end gap (Figure 4).
3. Clean carbon from end of rings and insert approximately 1.0 in. (25 mm) into cylinder.

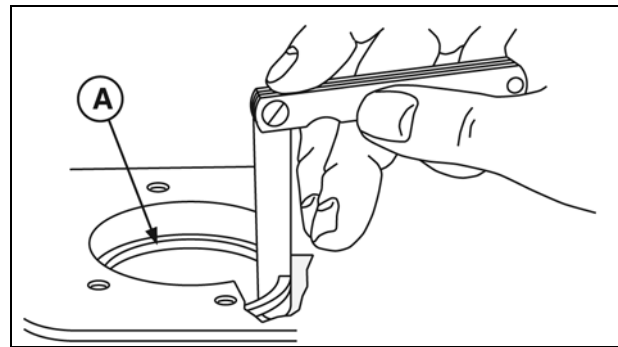

Figure 4

4. Check piston pin bore (Figure 5).

Inspect Piston and Rings

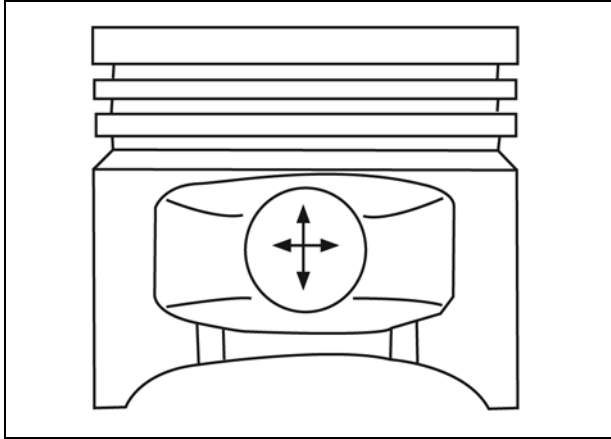

Figure 5

- Replace if greater than 0.710 in. (18.03 mm) or 0.0004 in. (0.01 mm) out of round.

Check Piston Pin and Connecting Rod

1. Check piston pin (Figure 6).

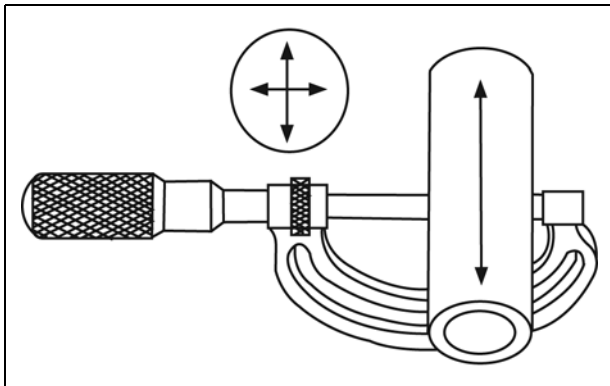

Figure 6

- Replace if less than 0.708 in. (17.98 mm) or 0.0004 in. (0.01 mm) out of round.

2. Check piston pin bearing (Figure 7).

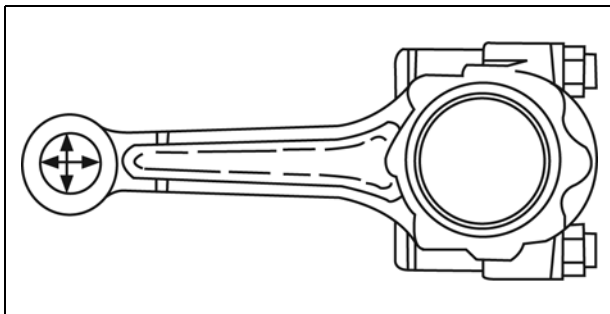

Figure 7

- Replace if greater than 17.98 mm (0.708 in.) or 0.01 mm (0.004 in.) out of round.

3. Check crankpin bearing end of connecting rod (Figure 8).

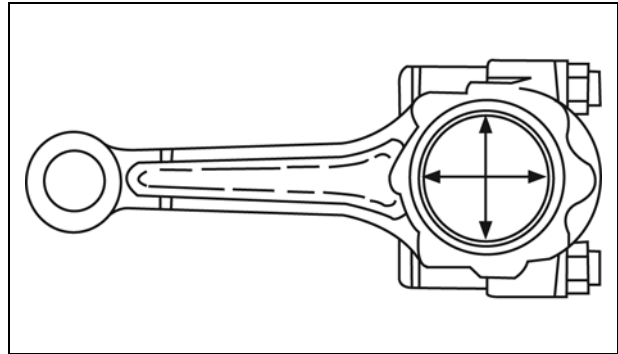

Figure 8

- Maximum out of round: 0.0008 in. (0.02 mm)
- If out of round exceeds specification shown, the connecting rod must be replaced.

4. Check for bent or twisted connecting rod (Figure 9).

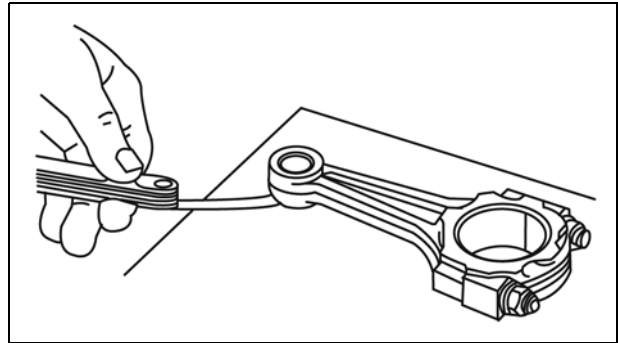

Figure 9

NOTE: Thrust faces must be free of any burrs or nicks or connecting rod will not lay flat on surface plate.

- With connecting rod on a surface plate, any distortion will be evident by a rocking motion.
- If a 0.002 in. (0.05 mm) feeler gauge can be inserted at piston pin end of connecting rod, the rod must be replaced.

Assemble Piston and Connecting Rod

1. Assemble piston to connecting rod using Piston Pin Fixture #19419.

NOTE: Arrow on piston (**A**, Figure 10) and ID mark (**B**) on rod must face same side.

2. Lubricate piston pin with engine oil. Then, insert threaded driver (**C**) through piston pin (**D**) and thread into pilot (**E**).
3. With arrow on piston and ID mark on rod facing up, insert pilot through piston and connecting rod.

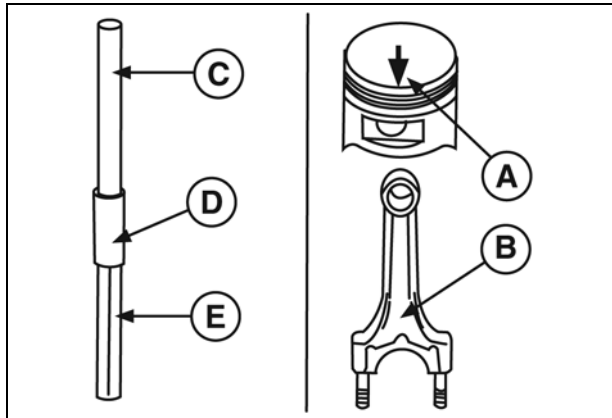

Figure 10

4. Insert piston pin stop (**A**, Figure 11) in bottom of piston support (**B**).

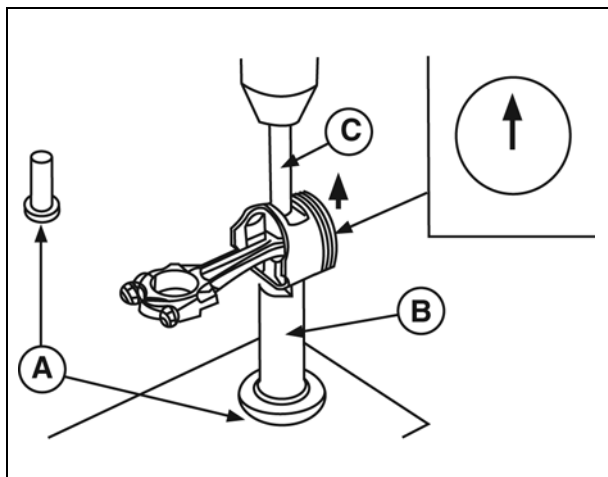

Figure 11

5. With arrow on piston up, place assembly onto support.
6. Press in piston pin until pilot bottoms on stop.
7. After assembly, make sure the piston rotates freely on connecting rod.

Assemble Piston Rings to Piston

1. Install oil ring expander first.
2. Spiral bottom oil control ring into top ring groove, center ring groove, and then into position below expander (Figure 12).
3. Repeat for upper oil control ring.

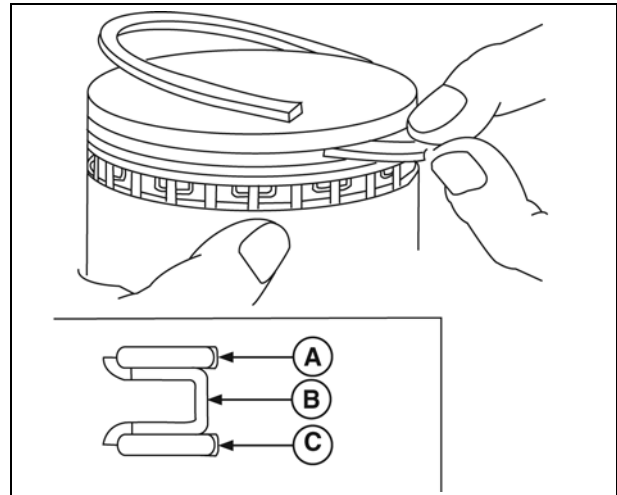

Figure 12

4. Using ring expander, install center compression ring then, top compression ring with ID marks up (Figure 13).
5. Stagger ring end gaps.
6. Rotate oil control ring ends 180° from each other.

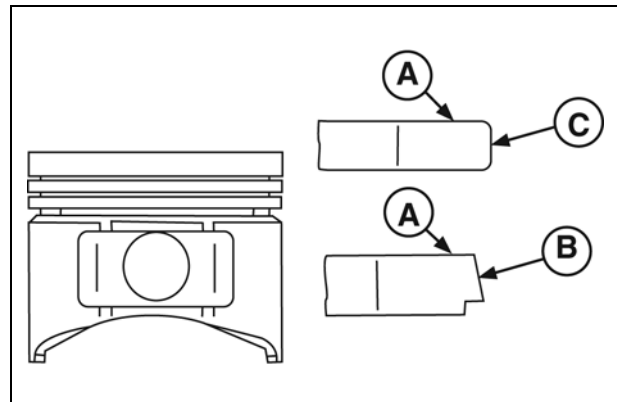

Figure 13

SECTION 9 - CYLINDER BLOCK ASSEMBLY

INSTALL CRANKSHAFT-	-58
INSTALL PISTONS AND CONNECTING RODS	-59
GENERAL ASSEMBLY-	-59
INSTALL TIMING GEAR CASE, CAMSHAFT, AND GEARS	-60
INSTALL OIL PAN	-62
INSTALL ALTERNATOR	-62
GENERAL ASSEMBLY	-62

Install Crankshaft

1. Install main bearings in cylinder block.

NOTE: Upper bearing has an oil groove (A, Figure 1) and oil holes (B).

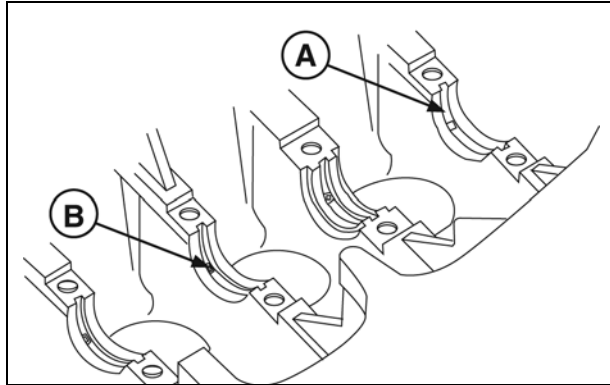

Figure 1

2. Install upper main bearings in their respective saddles.
3. Ensure bearing is seated in saddle and tang in bearing is aligned with notch in saddle. Lubricate bearings with engine oil.
4. Install lower main bearings in bearing caps (Figure 2).

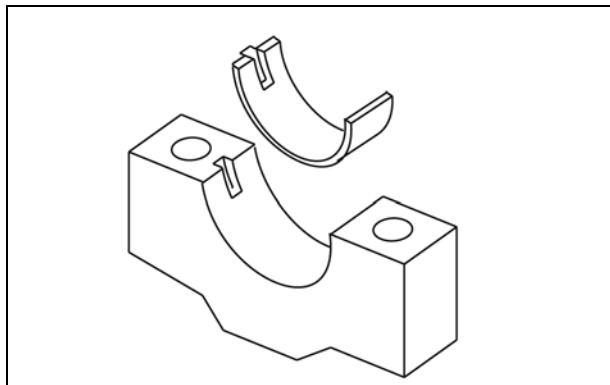

Figure 2

5. Be sure bearing is seated in bearing cap and tang in bearing is aligned with notch in bearing cap.
6. Lubricate bearings with engine oil.
7. Install crankshaft with gear facing front of cylinder block (Figure 3). Take care not to damage journals or bearings.
8. Install crankshaft shims on No. 3 main bearings web with grooves facing out. Lubricate journals with engine oil.

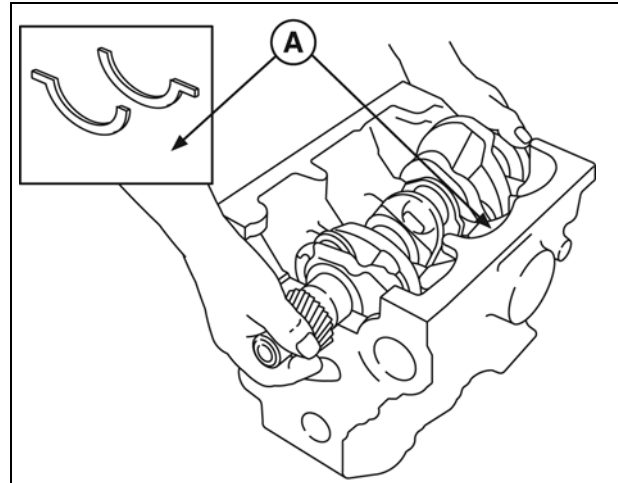

Figure 3

9. Install main bearing caps. Lubricate threads of screws with engine oil.
10. Install bearing caps in their respective positions with arrows facing front.
11. Start with Number 3 bearing cap (Figure 4) and torque bearing caps one at a time in sequence shown to values listed in Section 14 - Engine Specifications.

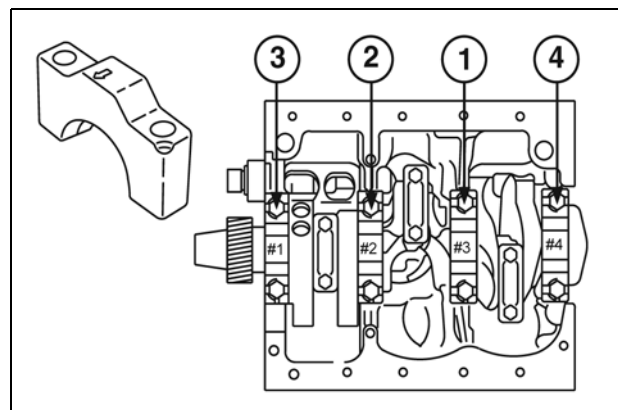

Figure 4

12. Recheck crankshaft end play.
 - Crankshaft end play - 0.001 - 0.009 in. (0.025 - 0.23 mm)

NOTE: After torquing bearing cap, make sure crankshaft rotates freely before proceeding to next bearing cap.

Install Pistons and Connecting Rods

1. Install connecting rod bearings. Be sure tang on bearing is seated in notch (**A**, Figure 5) in connecting rod and cap.
2. Install a piece of vinyl tubing (**B**) over each connecting rod screw to prevent damage to screw threads or crankpin when installing piston and connecting rod.

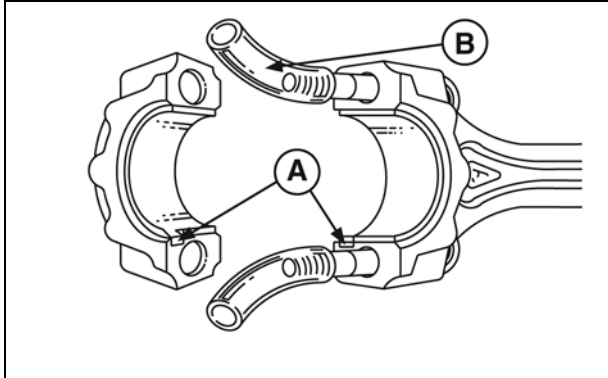

Figure 5

3. Rotate crankshaft so that crankpin is at bottom of stroke. Lubricate cylinder walls, pistons and rings, bearings, and crankpins.
4. Using Tool Ring Compressor #19070, install piston and connecting rod assemblies with arrow on piston facing front.
5. Install connecting rod cap with ID mark (**A**, Figure 6) facing front. Lubricate threads and torque nuts to values listed in Section 14 - Engine Specifications.

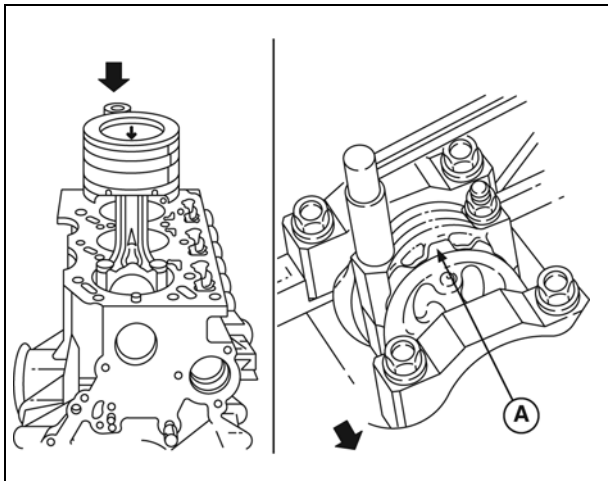

Figure 6

NOTE: After torquing rod cap, make sure crankshaft rotates freely before proceeding to next cylinder.

General Assembly

1. Install gasket, oil pick-up tube and strainer (Figure 7). Torque screws to values listed in Section 14 - Engine Specifications.

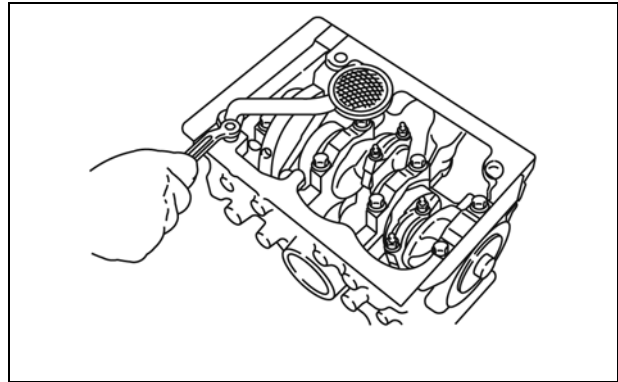

Figure 7

2. Install gasket and rear seal retainer (**A**, Figure 8). Torque screws to values listed in Section 14 - Engine Specifications.
3. Install starter motor (**B**) and torque screws to values listed in Section 14 - Engine Specifications.

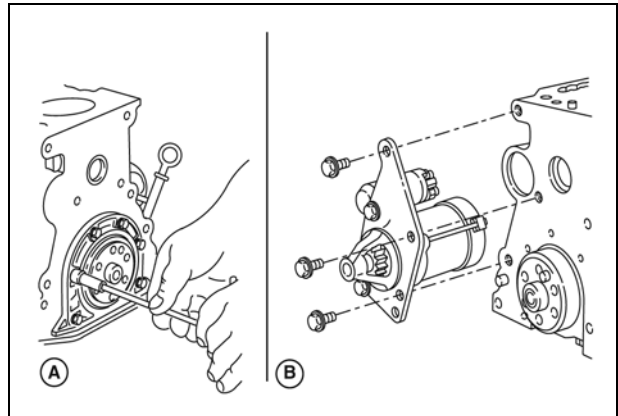

Figure 8

4. Install flywheel and flywheel holder (**A**, Figure 9).
5. Apply sealant to flywheel screws and torque to values listed in Section 14 - Engine Specifications.

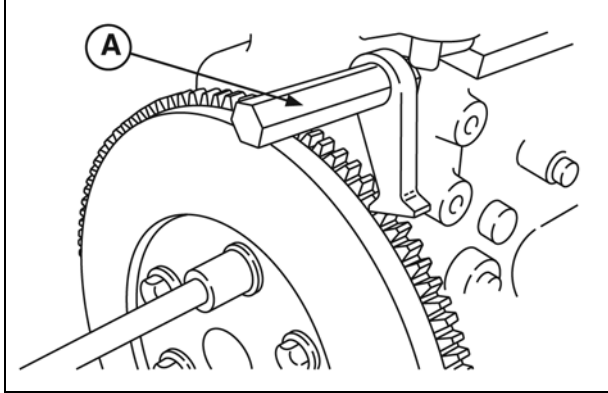

Figure 9

Install Timing Gear Case, Camshaft, and Gears

1. Lubricate oil pump rotor (**A**, Figure 10) with engine oil and install in cylinder block.
 - ID mark (**B**) on rotor must face cylinder block.

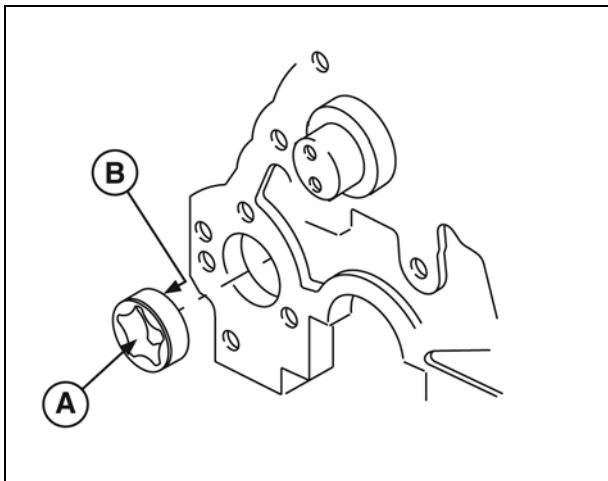

Figure 10

2. Install timing gear case with new gasket (Figure 11). It may be necessary to rotate oil pump drive to engage oil pump rotors.
3. Note position, length, and quantity of screws as shown.
 - M6 x 1.1 in. (M6 x 28mm): 4 (**A**).
 - M6 x 1.5 in. (M6 x 16mm): 1 (**B**).
4. Torque screws to values listed in Section 14 - Engine Specifications.

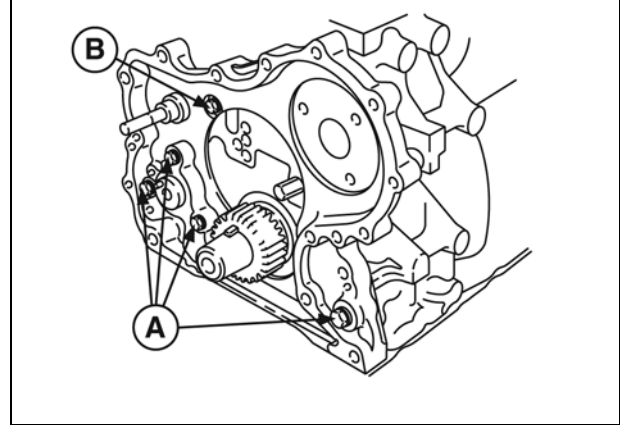

Figure 11

5. Lubricate and install camshaft in cylinder block. Take care not to damage lobes or cam bearing.
6. Install camshaft retainer (**A**, Figure 12).
7. Install three screws (**B**) and torque to values listed in Section 14 - Engine Specifications.

NOTE: Position camshaft retainer so that the center hole does not interfere with camshaft.

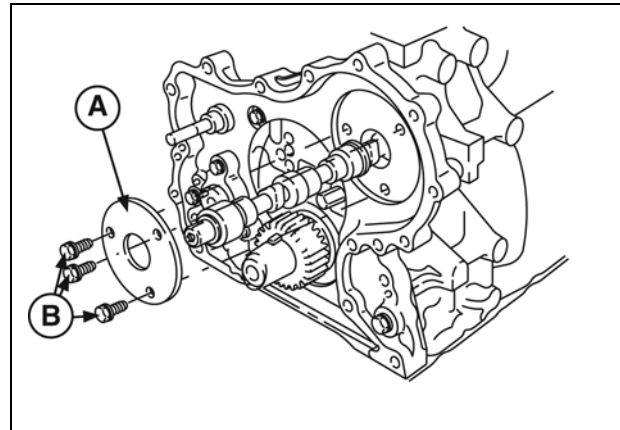

Figure 12

8. Rotate crankshaft so that the key is at the 12 o'clock position (**A**, Figure 13).

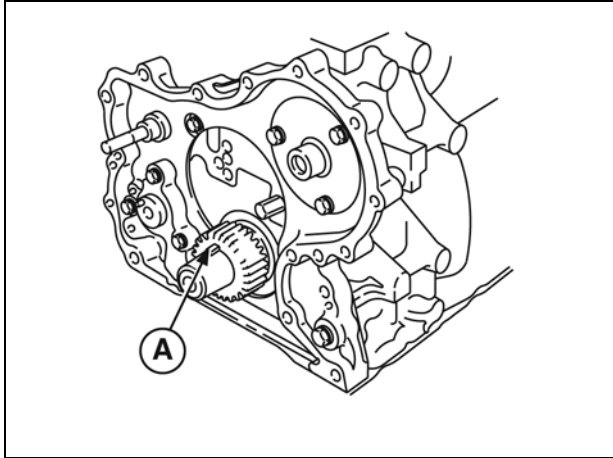

Figure 13

9. Assemble idler gear shaft (A, Figure 14) with ID mark (B) up.

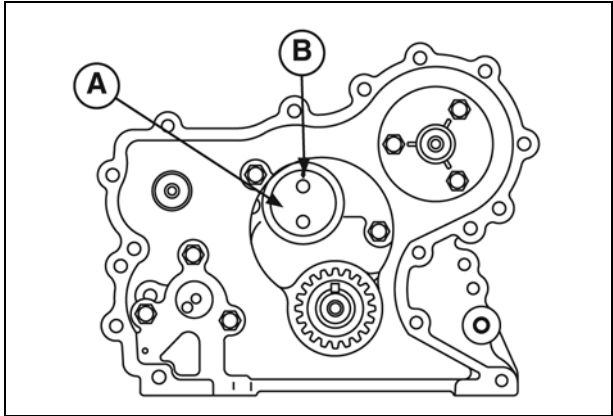

Figure 14

Engine models 430000 and 580000 after date code 990111007 are equipped with right angle helical timing gears. Timing marks are identified by letters (A, AA, B, BB, etc.), instead of numbers. The timing procedure is the same.

10. With the crankshaft key at the 12 o'clock position, assemble idler gear so that timing mark 11 (AA) is aligned with timing mark 1 (A) in crankshaft gear, timing mark 22 (BB) is aligned with timing mark 2 (B) on camshaft gear (Figure 15).

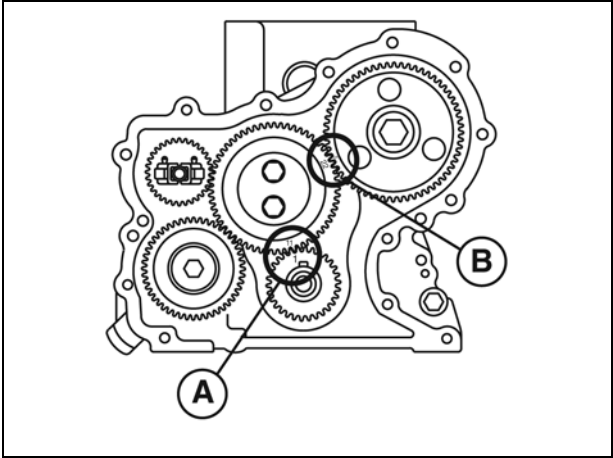

Figure 15

11. Install camshaft gear (A, Figure 16), idler gear (B), and oil pump gear (C). Torque screws to values listed in Section 14 - Engine Specifications.

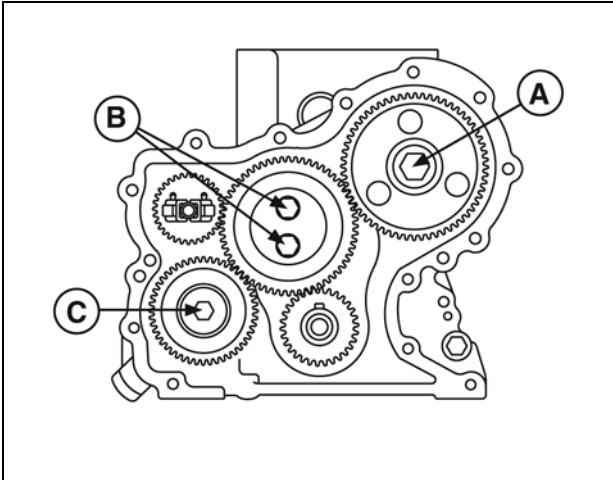

Figure 16

12. Install timing gear cover with new gasket.
13. Note position, length, and number of screws (Figure 17).
- M6 x 2.5 in. (M6 x 65 mm): 2 (A).
 - M6 x 2.1 in. (M6 x 55 mm): 3 (B).
 - M6 x 1.1 in. (M6 x 30 mm): 7 (C).
 - M6 Nuts: 2 (D).

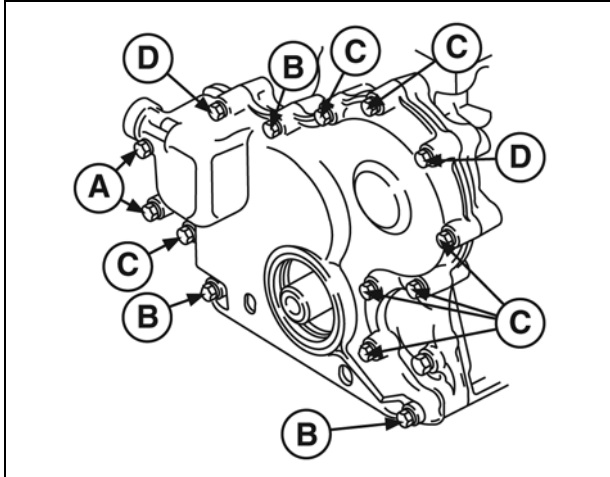

Figure 17

14. Torque screws to values listed in Section 14 - Engine Specifications.
15. Install crankshaft pulley with timing mark at 12 o'clock position (Number 1 cylinder).

NOTE: Be sure alignment pin in crankshaft gear is seated in hole in pulley.

16. Torque screw to values listed in Section 14 - Engine Specifications.
17. Remove flywheel holder.
18. Install trigger assembly (A, Figure 18) and wire.

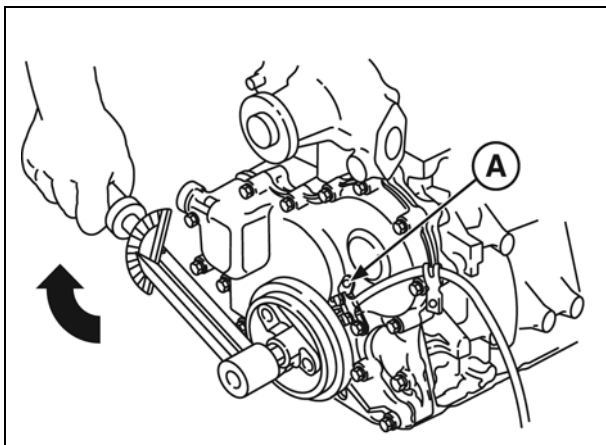

Figure 18

Install Oil Pan

1. Install oil pan with new gasket.
2. Apply a small bead of sealant to crankcase areas (A, Figure 19).

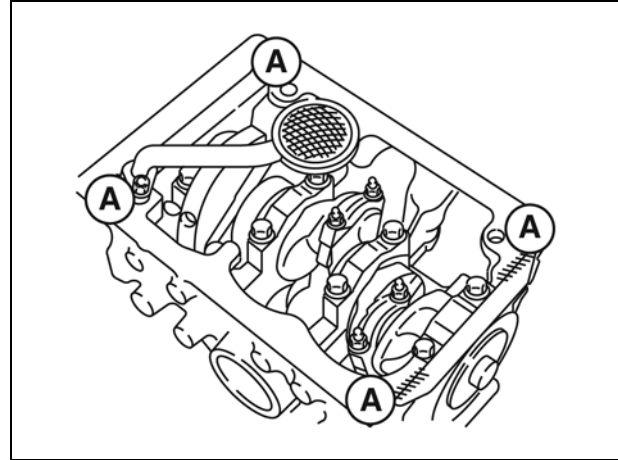

Figure 19

3. Torque screws to values listed in Section 14 - Engine Specifications.

Install Alternator

1. Install alternator bracket and alternator (Figure 20).

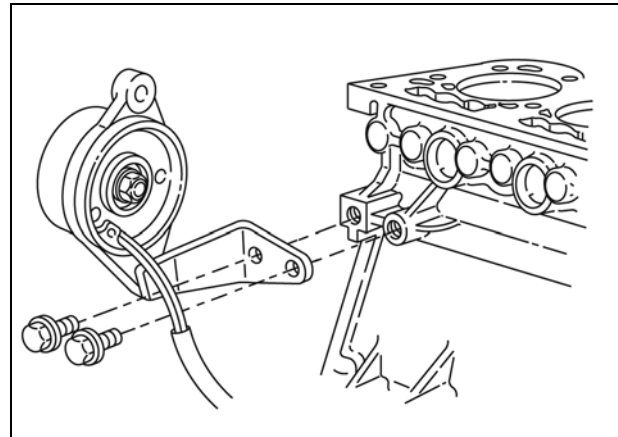

Figure 20

2. Torque screws to values listed in Section 14 - Engine Specifications.

General Assembly

1. Lubricate tappets with engine oil and install in cylinder block.
2. See Section 2 for installation of cylinder head and related components.
3. See Section 3 for governor adjustment procedure.

SECTION 10 - CARBURETOR AND RELATED COMPONENTS

MANUAL CHOKE CARBURETOR - - - - -	66
REMOVE CARBURETOR - - - - -	66
DISASSEMBLE CARBURETOR - - - - -	66
CLEAN CARBURETOR - - - - -	68
INSPECT CARBURETOR - - - - -	68
CHECK THROTTLE, CHOKE SHAFT, AND BODY - - - - -	68
ASSEMBLE CARBURETOR - - - - -	69
INSTALL THROTTLE SHAFT - - - - -	69
INSTALL CHOKE VALVE - - - - -	69
INSTALL FLOAT - - - - -	70
INSTALL CARBURETOR - - - - -	70
INITIAL CARBURETOR ADJUSTMENT - - - - -	71
FINAL CARBURETOR ADJUSTMENT - - - - -	71
AUTOMATIC CHOKE CARBURETOR - - - - -	73
REMOVE CARBURETOR - - - - -	73
DISASSEMBLE CARBURETOR - - - - -	73
CLEAN CARBURETOR - - - - -	75
INSPECT CARBURETOR - - - - -	75
CHECK THROTTLE, CHOKE SHAFT, AND BODY - - - - -	76
ASSEMBLE CARBURETOR - - - - -	76
CHECK VACUUM CHOKE BREAK - - - - -	78
ADJUST CHOKE PRE-LOAD LEVER - - - - -	78
CHECK P.T.C. HEATER - - - - -	79
INSTALL CARBURETOR - - - - -	79
INSTALL VACUUM LIMITER - - - - -	79

INITIAL CARBURETOR ADJUSTMENT -----280

FINAL CARBURETOR ADJUSTMENT -----280

ELECTRIC FUEL PUMP -----81

CHECK FUEL PUMP OUTPUT -----82

TEST EQUIPMENT -----82

TEST FUEL PUMP WIRING -----82

ANTI-AFTERFIRE SOLENOID -----83

TEST ANTI-AFTERFIRE SOLENOID -----83

TEST SOLENOID -----83

FUEL FILTER -----84

CARBURETOR MAIN JETS -----84

ELECTRONIC FUEL INJECTION SYSTEM -----85

EFI COMPONENTS -----85

TROUBLESHOOTING -----89

ELECTRICAL SYSTEM -----89

FAULT CODES -----90

FLASH CODE ON MIL INDICATOR -----91

TROUBLESHOOTING CHARTS -----92

MANUAL CHOKE CARBURETOR

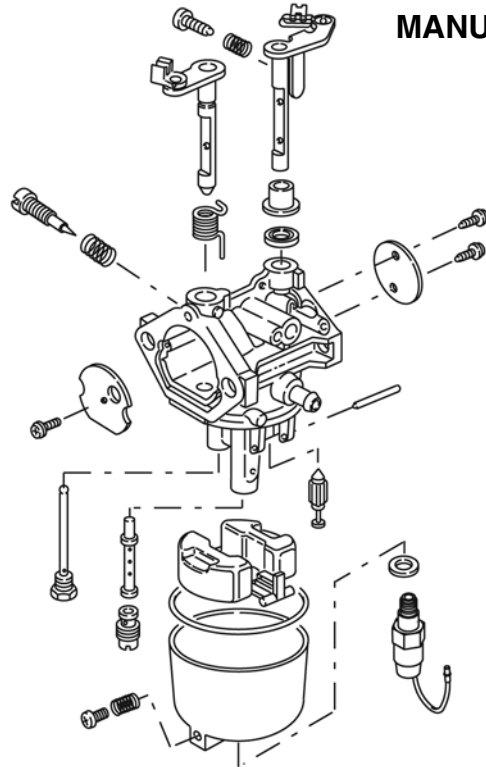

10

AUTOMATIC CHOKE CARBURETOR

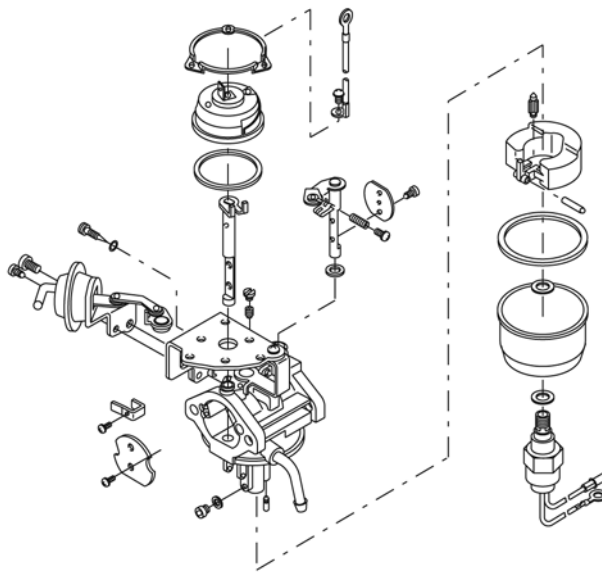

Manual Choke Carburetor

Remove Carburetor

1. Disconnect fuel line (A, Figure 1).
2. Remove air cleaner tube from carburetor air horn. Disconnect fuel solenoid wire, if equipped.

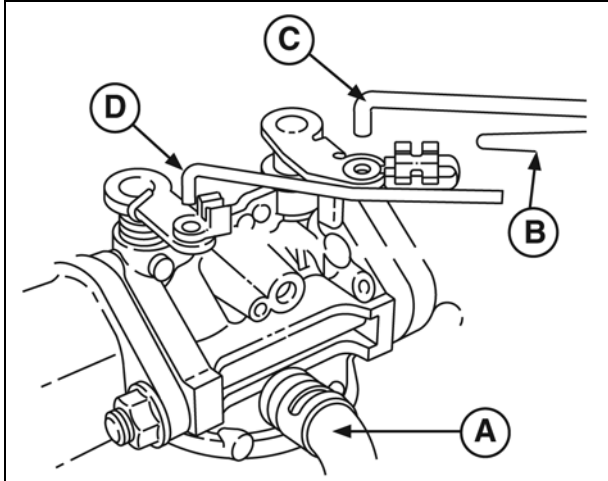

Figure 1

3. Unhook governor link spring (B) from throttle lever and disconnect governor link (C).
4. Disconnect choke link (D) at choke lever. Proceed to Step 7.

NOTE: Early style choke links were manufactured with a “Z” bend (Figure 3). To remove choke link the governor control bracket must be removed. Proceed to Steps 5 and 6.

5. Disconnect governor spring (A, Figure 2). Remove two screws and governor control bracket (B) from intake manifold.

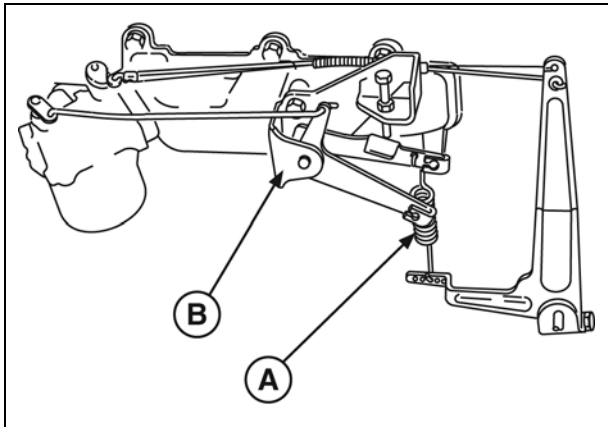

Figure 2

6. Remove choke link (A, Figure 3) from choke lever.

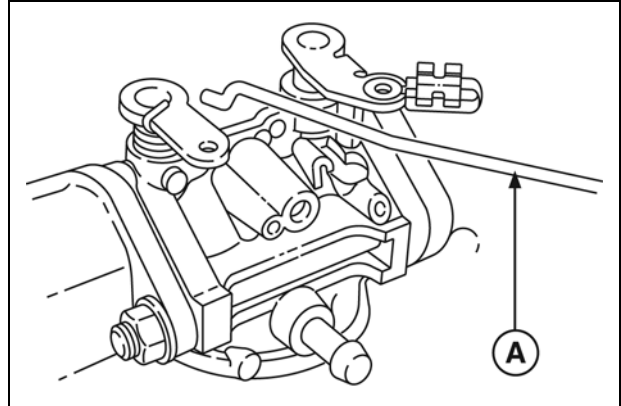

Figure 3

7. Remove nuts, air horn (A, Figure 4), carburetor (B), and insulator (C). Discard gaskets (D).

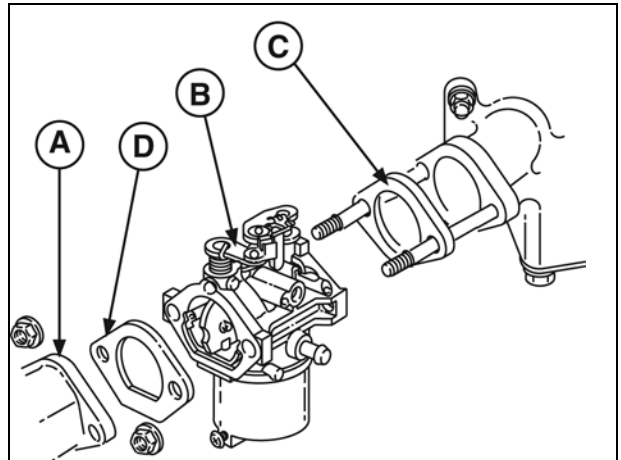

Figure 4

Disassemble Carburetor

1. Remove anti-afterfire solenoid (A, Figure 5), bowl screw (B), washer (C), and carburetor bowl (D).

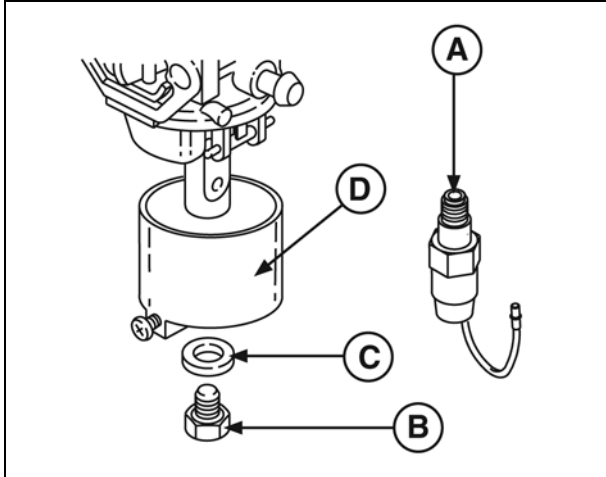

Figure 5

2. Drive out float hinge pin (A, Figure 6) from choke plate side of carburetor (B) with a small punch. Remove float (C) and fuel inlet valve (D).

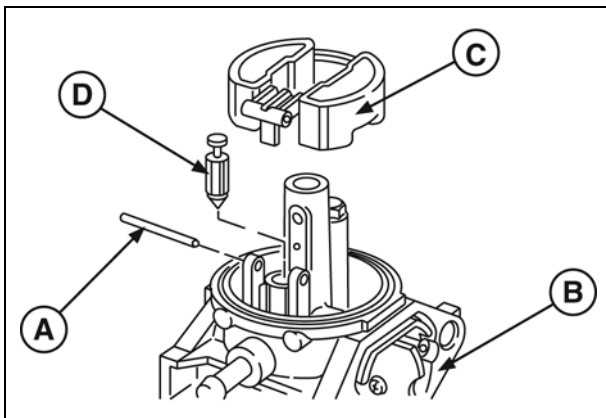

Figure 6

3. Remove carburetor bowl gasket (A, Figure 7).

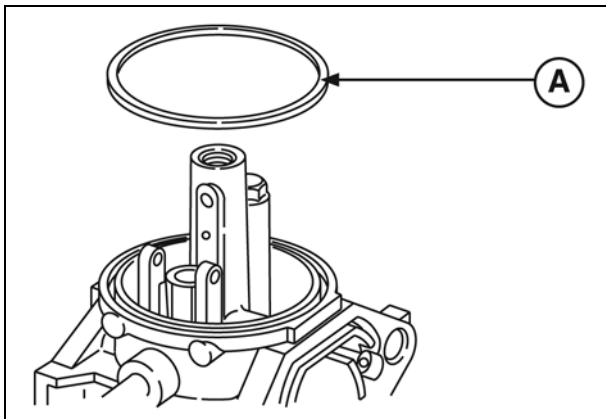

Figure 7

4. Remove fixed high speed jet (A, Figure 8).
5. Remove emulsion tube (B).

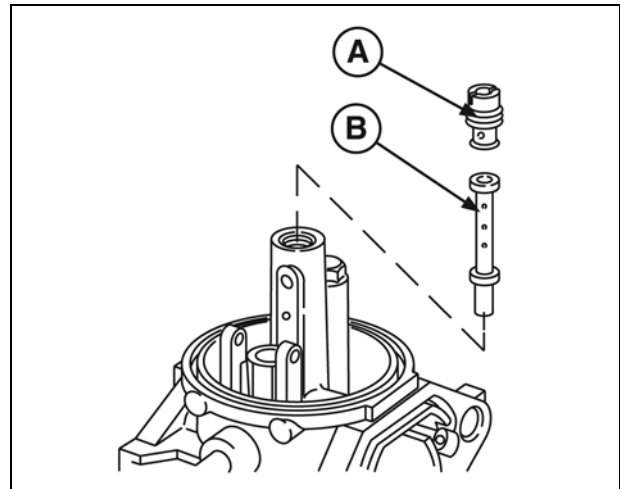

Figure 8

NOTE: Consult the illustrated parts list for correct part number for special high altitude jet, if required.

6. Remove idle jet (A, Figure 9).

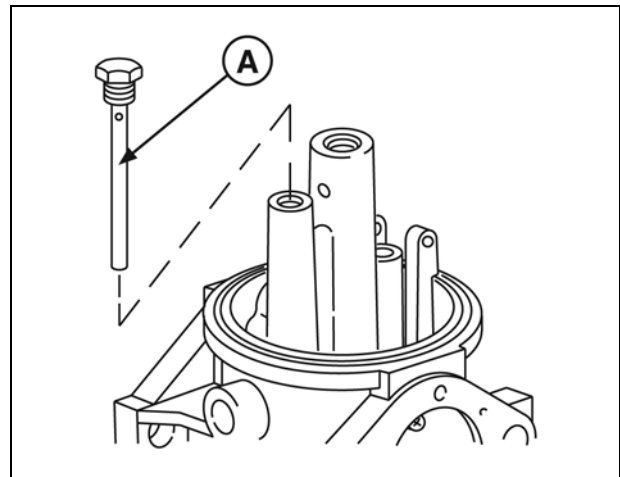

Figure 9

7. If idle mixture screw (A, Figure 10) is equipped with adjustment limiter cap, use pliers to remove it before removing idle mixture valve.
8. Remove idle mixture screw and spring (B).

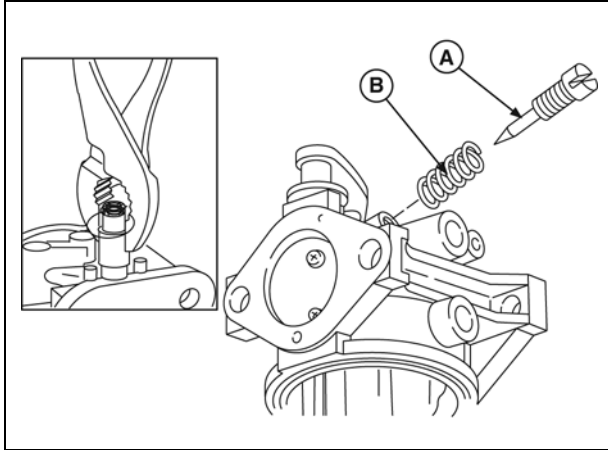

Figure 10

9. Remove screw and choke plate (A, Figure 11).
10. Remove choke shaft (B) and spring (C).

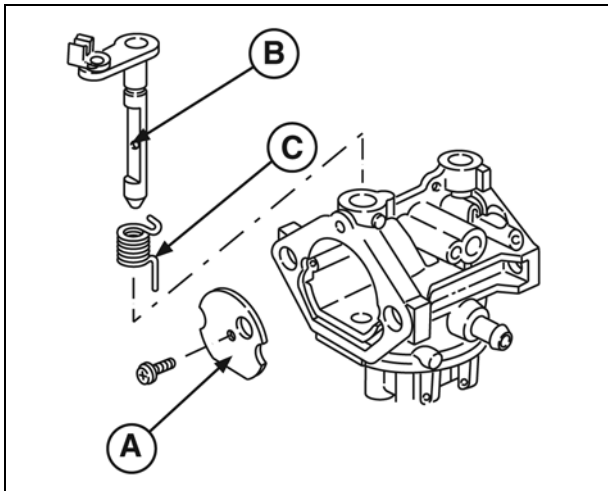

Figure 11

NOTE: If engine is equipped with an electronic governor system, DO NOT remove throttle plate or throttle shaft. This is a precision assembly and should not be disassembled.

11. If engine is not equipped with an electronic governor, proceed to step 12.
12. Mark throttle plate (A, Figure 12) before removing so that it may be reinstalled in the same position. Sides of throttle plate are beveled.
13. Remove two screws, throttle plate, throttle shaft (B) with collar (C) and seal (D). Discard seal.

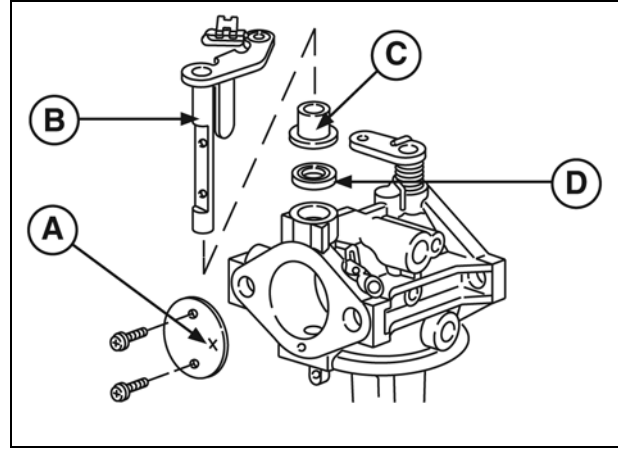

Figure 12

Clean Carburetor

Remove gasket material from mounting surfaces. Gummy or dirty carburetors should be cleaned in a carburetor cleaner. DO NOT soak rubber, neoprene, or plastic parts in cleaner.

NOTICE: If engine is equipped with an electronic governor system, DO NOT clean carburetor in carburetor cleaner. The carburetor is equipped with sealed ball bearings for the throttle shaft, which will be damaged if the carburetor is immersed in carburetor cleaner. Ball bearings are not replaceable.

Inspect Carburetor

Inspect all parts for wear, cracks, nicks, and burrs. Inspect float for leaks. Replace all damaged parts.

Inspect Throttle, Choke Shaft, and Body for Wear

1. Lay carburetor on flat surface and check throttle and choke shaft clearance (Figure 13).

NOTE: Throttle shaft and choke shaft clearance must not exceed 0.010 in. (.25 mm).

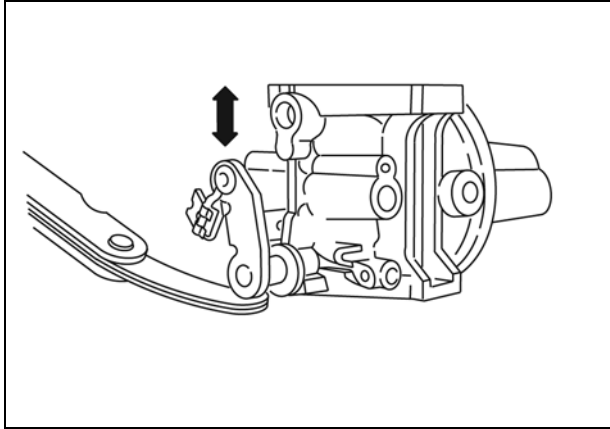

Figure 13

2. Inspect throttle shaft and choke shaft for wear (Figure 14).

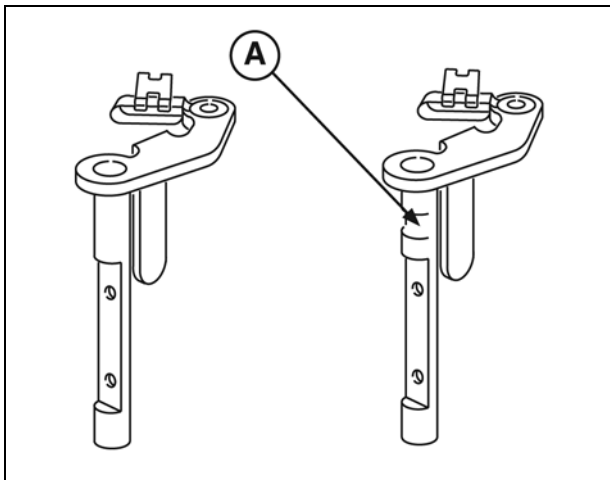

Figure 14

- Replace if worn.
- If carburetor body is worn, replace carburetor.

Assemble Carburetor

NOTE: When assembling carburetor, use new seals and gaskets.

Install Throttle Shaft

1. Install seal (A, Figure 15) with grooved side out.
2. Assemble collar (B) to throttle shaft and insert in body.
3. Install throttle plate and screws (C).

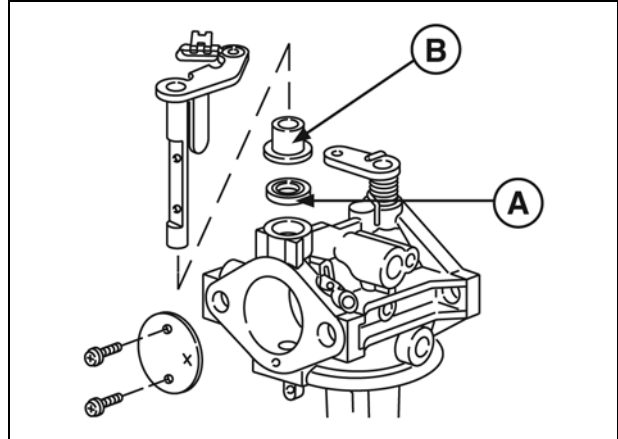

Figure 15

Install Choke Valve

1. Assemble spring (A, Figure 16) to choke shaft (B) and insert in body.
2. Rotate shaft clockwise to pre-load spring.
3. Install choke plate with hole facing fuel inlet side of body (C).

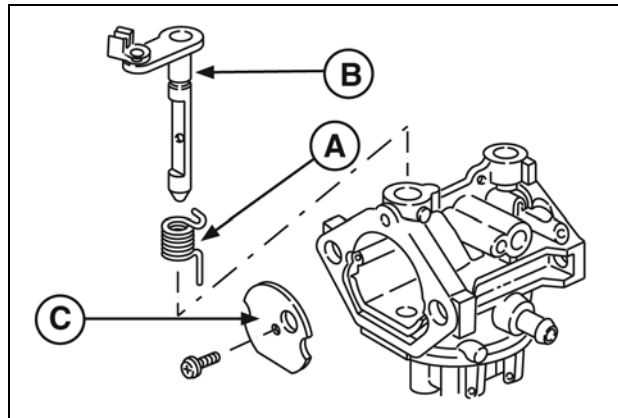

Figure 16

4. Assemble the emulsion tube (A, Figure 17), the fixed high speed jet (B), and the idle jet (C).

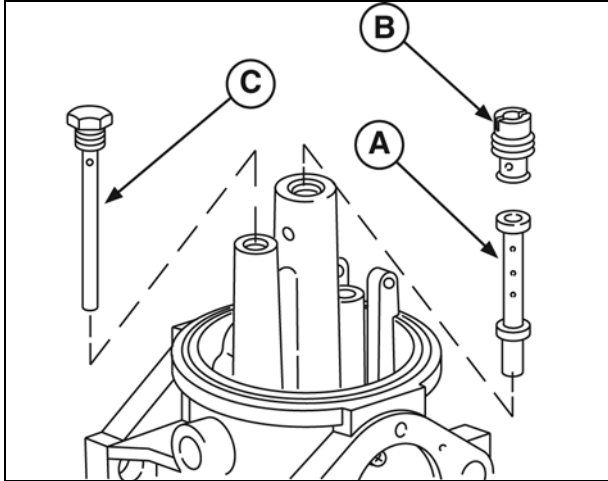

Figure 17

Install Float

1. Assemble inlet valve (A, Figure 18) to float.
2. Install float hinge pin (B) from throttle side of carburetor.

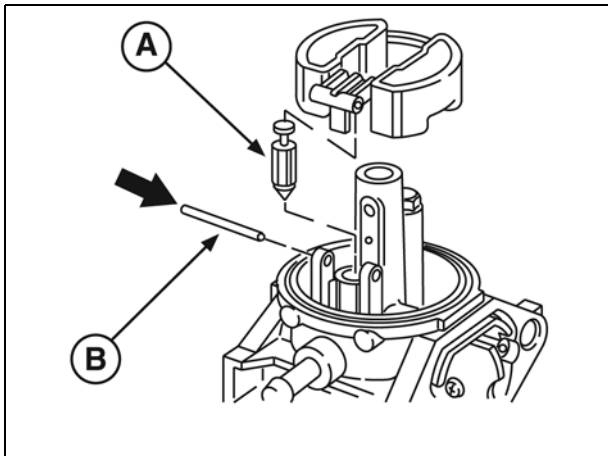

Figure 18

3. Install gasket (A, Figure 19) and float bowl (B).

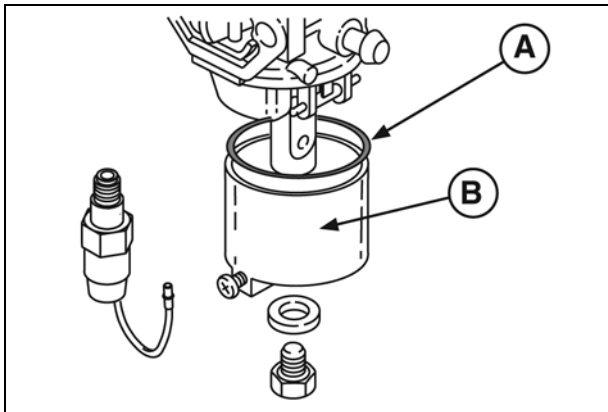

Figure 19

4. Install idle mixture screw (A, Figure 20) and spring (B).

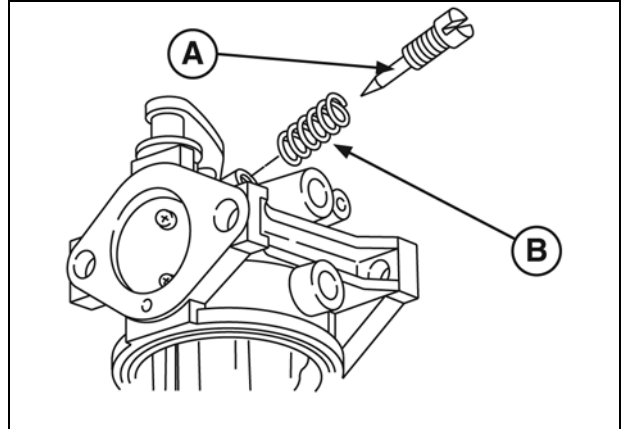

Figure 20

NOTE: DO NOT tighten idle mixture screw.

Install Carburetor

1. Assemble insulator (A, Figure 21) with gaskets, carburetor (B), and air horn (C) with gasket (D) to intake manifold.

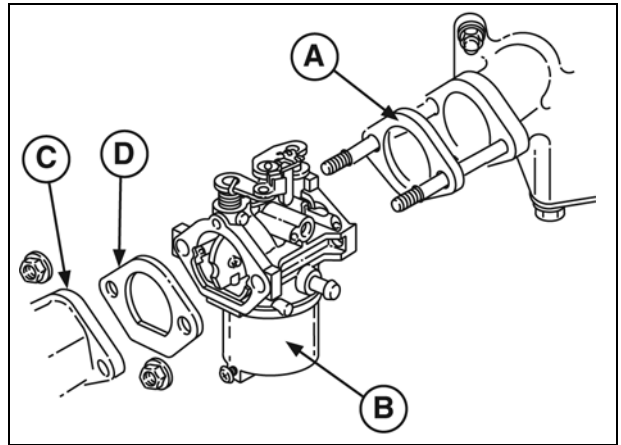

Figure 21

2. Torque nuts to values listed in Section 14 - Engine Specifications.
3. Install governor link, spring, and choke link.

NOTE: Proceed to Step 5 if choke link is early style with "Z" bend.

4. Reinstall air cleaner tube and fuel line.
5. Install choke link. Assemble governor control bracket to intake manifold. Torque screws to values listed in Section 14 - Engine Specifications.

- Assemble governor spring (A, Figure 22) to governor control lever (B).

NOTE: Governor spring must be installed in correct hole in governor control lever by engine model.

- Model 430400 - Top Hole
- Model 580400 - Bottom Hole

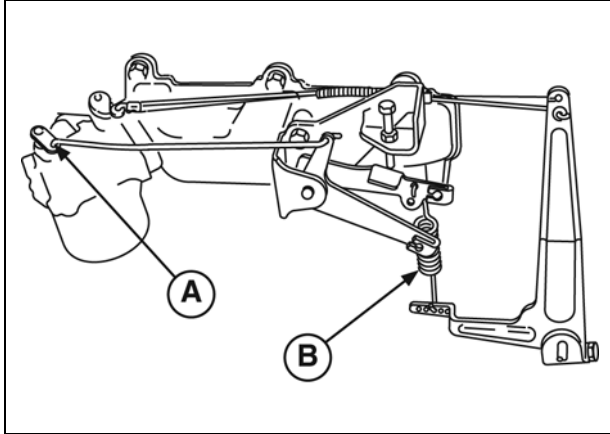

Figure 22

Initial Carburetor Adjustment

- Turn idle mixture screw clockwise until it just seats. **DO NOT FORCE**. Turn screw counter-clockwise 1/2 turn (Figure 23). This setting will permit engine to start.

NOTE: Final adjustment will be made with engine running.

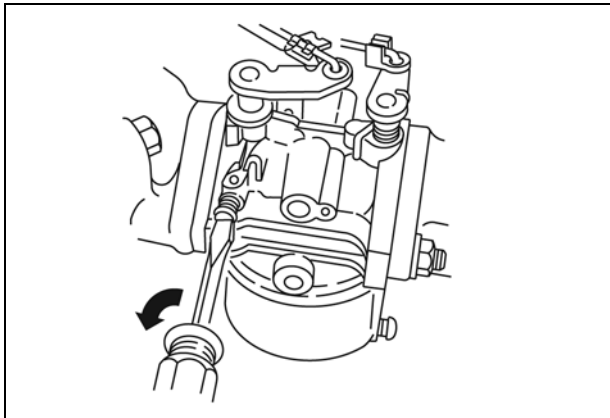

Figure 23

Final Carburetor Adjustment

NOTICE: All carburetor adjustments must be made with the air cleaner installed.

- Start and run engine at low speed for approximately five minutes. Or, if equipped with a temperature gauge, until needle moves from C or COLD position.
- With control lever on equipment in SLOW position, hold throttle lever (A, Figure 24) against idle speed screw and adjust idle speed to 1200 RPM.

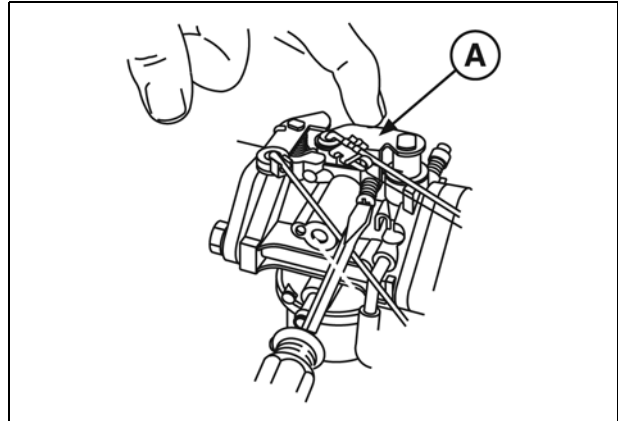

Figure 24

- SLOWLY turn idle mixture screw clockwise until engine speed just starts to slow (lean mixture).
- Then SLOWLY turn idle mixture screw counter-clockwise until engine speed just starts to slow (rich mixture).
- Turn idle mixture screw (A, Figure 25) to mid point between rich and lean.

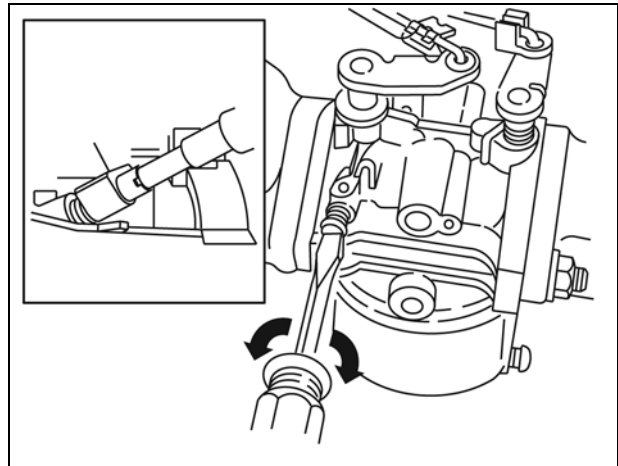

Figure 25

6. Hold throttle lever against idle speed screw and readjust idle speed to 1500 RPM, or equipment manufacturer's specification.

NOTE: If carburetor is equipped with an idle mixture limiter cap, install at this time.

7. Position limiter cap (**B**) so that stop(s) on the limiter cap are at mid point between stop(s) on carburetor body and press into position.

10

Automatic Choke Carburetor

The automatic choke consists of a vacuum choke break and a thermostat. The Intake manifold vacuum activates the vacuum choke break which partially opens the choke plate, to prevent over choking while the engine is being started. A vacuum limiter, located in the vacuum line, regulates vacuum to the vacuum choke break.

The thermostat contains a Positive Temperature Coefficient heater (P.T.C.) and a bi-metal spring which opens the choke plate gradually as the engine is running. When the keyswitch is turned "ON," the battery current activates the P.T.C. heater which heats the bi-metal spring.

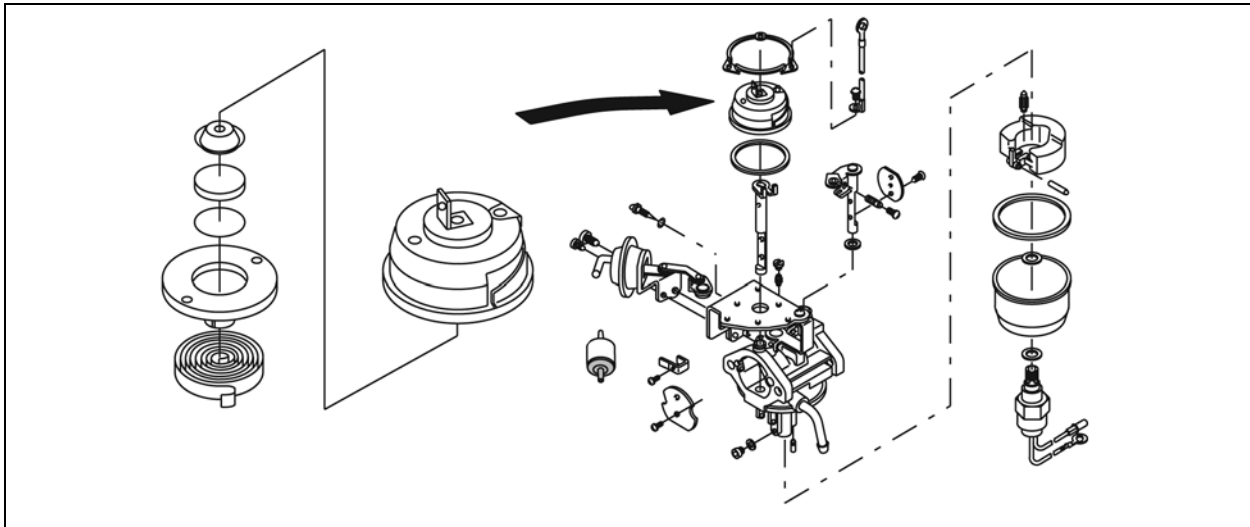

The P.T.C. Heater is a heat sensitive semiconductor porcelain. As the P.T.C. heater temperature rises, resistance increases, which regulates battery current to the heater and maintains the proper temperature for the bi-metal spring.

Automatic Choke Carburetor

Remove Carburetor

1. Disconnect fuel line and remove air cleaner tube from carburetor air horn. Disconnect vacuum line (A, Figure 26) from vacuum choke break. Disconnect wires from fuel shut off solenoid and automatic choke.
2. Unhook governor link spring (B) from throttle lever and disconnect governor link (C).

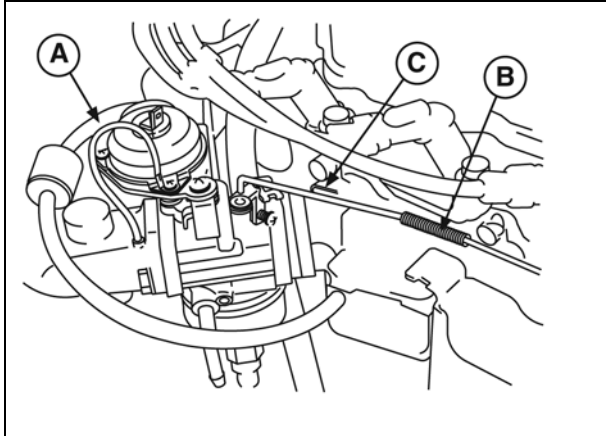

Figure 26

3. Remove two nuts and ground wire (A, Figure 27) from solenoid, air horn (B), carburetor (C), and insulator (D). Discard gaskets.

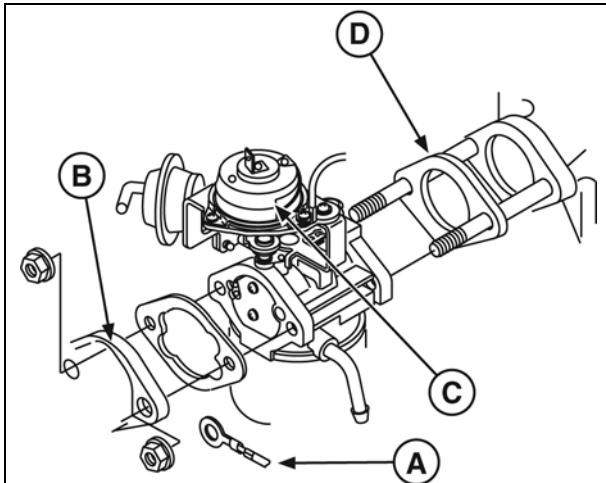

Figure 27

Disassemble Carburetor

1. Remove fuel shut off solenoid (A, Figure 28) and gasket (B). Remove float bowl (C) and bowl shim gasket (D).

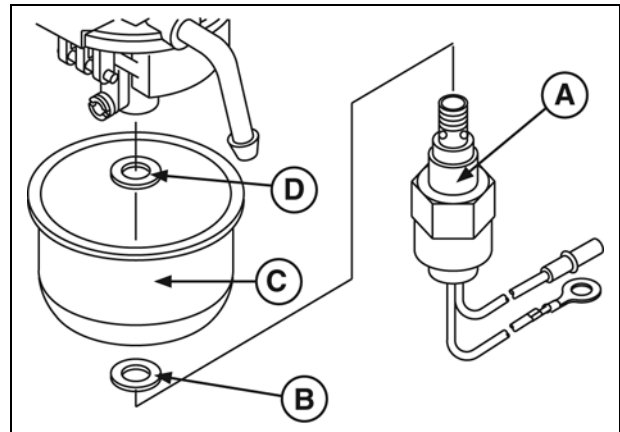

Figure 28

NOTE: The float hinge pin (A, Figure 29) is swaged in one side. When removing, drive hinge pin from side opposite swage.

2. Drive out float hinge pin with a small punch. Remove float and fuel inlet valve (B).
3. Remove idle passage plug (C).

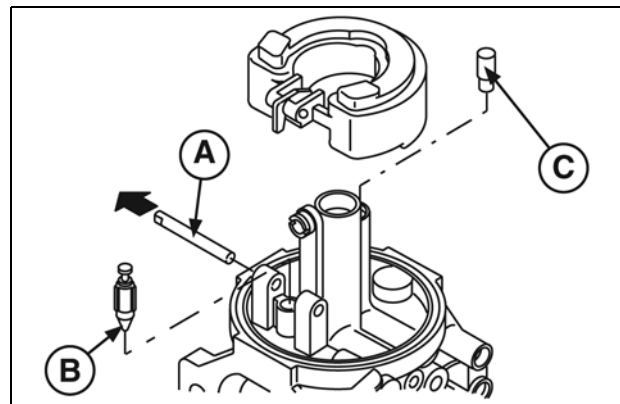

Figure 29

4. Remove rubber float bowl gasket (A, Figure 30).

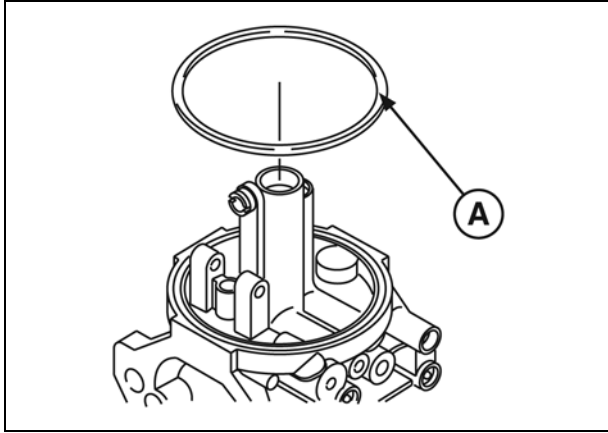

Figure 30

5. Remove fixed main jet (A, Figure 31) and gasket (B). Discard gasket.

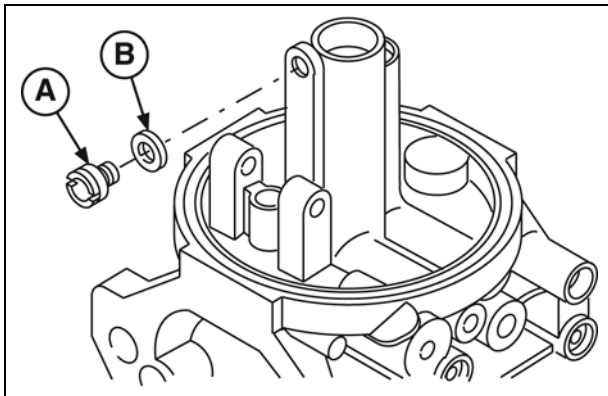

Figure 31

6. Remove three screws, thermostat retainer (A, Figure 32) and ground wire (B). Discard thermostat gasket (C).

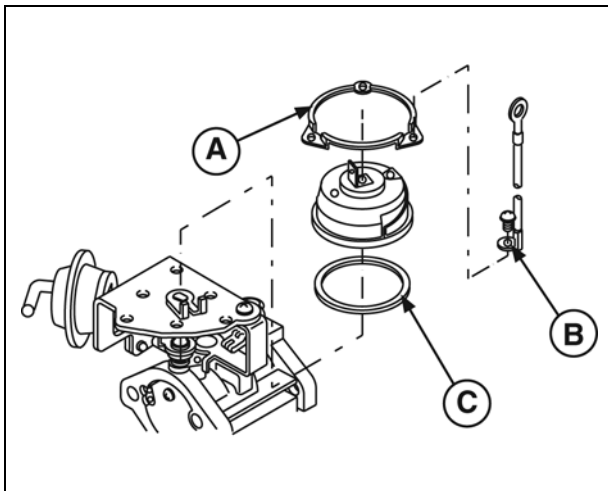

Figure 32

7. Remove screw and choke pre-load lever (A, Figure 33).

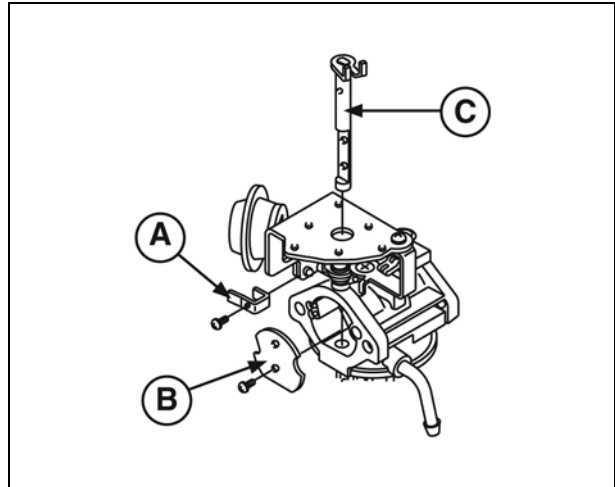

Figure 33

8. Remove two screws, choke plate (B) and choke shaft (C).

9. Remove two screws and vacuum choke break (A, Figure 34).

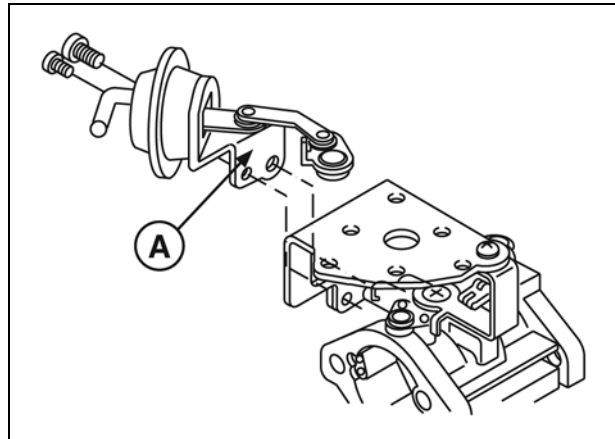

Figure 34

10. Remove idle jet plug (A, Figure 35) and idle jet (B).

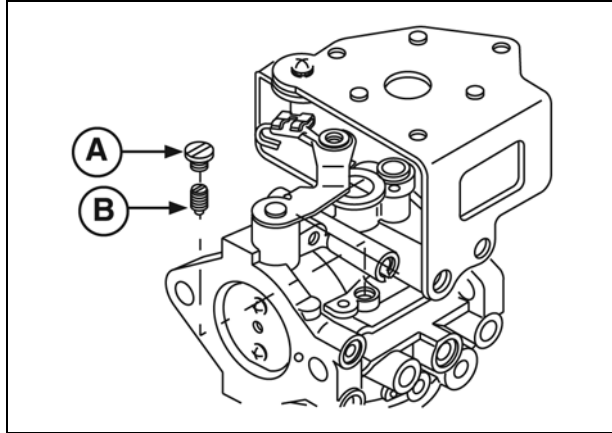

Figure 35

11. Remove idle mixture screw (A, Figure 36) and o-ring (B). Discard o-ring.

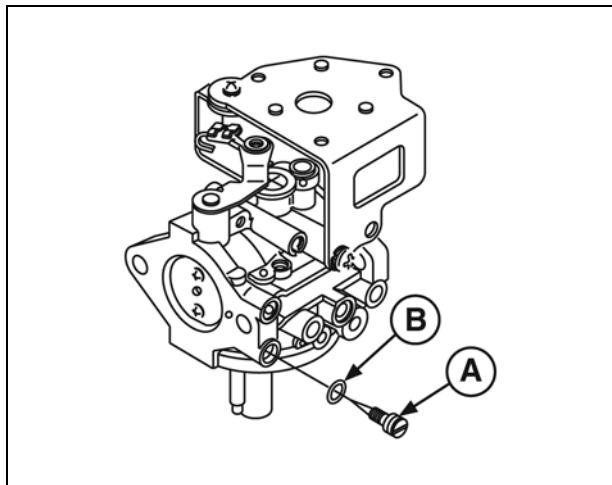

Figure 36

NOTE: If engine is equipped with an electronic governor system, DO NOT remove throttle plate or throttle shaft. This is a precision assembly and should not be disassembled.

If engine is not equipped with an electronic governor, proceed to Step 12.

12. Mark throttle plate (A, Figure 37) before removing so that it may be reinstalled in the same position. The sides of the throttle plate are beveled.
13. Remove two screws, throttle plate, throttle shaft (B), and seal (C). Discard seal.

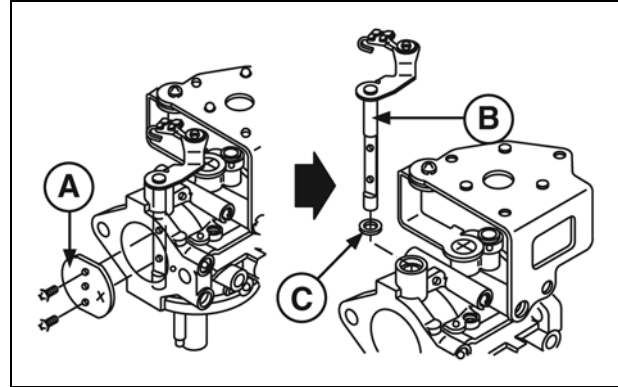

Figure 37

Clean Carburetor

Remove gasket material from mounting surfaces. Gummy or dirty carburetors should be cleaned in a carburetor cleaner. DO NOT soak rubber, neoprene, or plastic parts in cleaner.

NOTICE: If engine is equipped with an electronic governor system, DO NOT clean carburetor in carburetor cleaner. The carburetor is equipped with sealed ball bearings for the throttle shaft, which will be damaged if the carburetor is immersed in carburetor cleaner. Ball bearings are not replaceable.

Inspect Carburetor

Inspect all parts for wear, cracks, nicks, and burrs. Inspect float for leaks. Replace all damaged parts.

Inspect Throttle, Choke Shaft, and Body

1. Lay carburetor on flat surface and check throttle and choke shaft clearance (Figure 38).

NOTE: Throttle shaft and choke shaft clearance must not exceed 0.010 in. (0.25 mm).

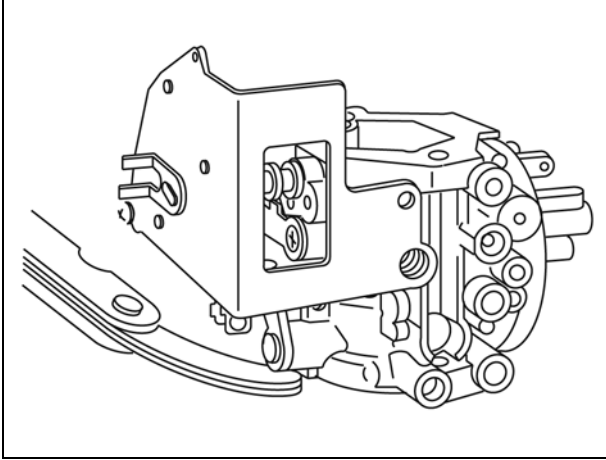

Figure 38

2. Inspect throttle shaft and choke shaft for wear (Figure 39).

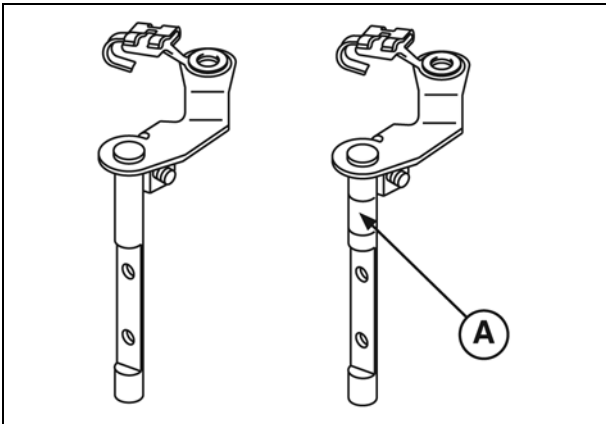

Figure 39

- Replace if worn.
- If carburetor body is worn, replace carburetor.

Assemble Carburetor

When assembling the carburetor, use new seals and gaskets.

1. Install throttle shaft (A, Figure 40) and new seal (B). Install throttle plate and screws (C).

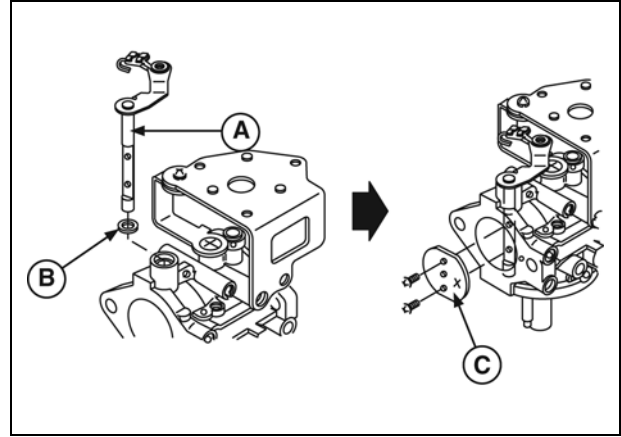

Figure 40

2. Install idle mixture screw (A, Figure 41) with new o-ring (B).

NOTE: Do not tighten idle mixture screw.

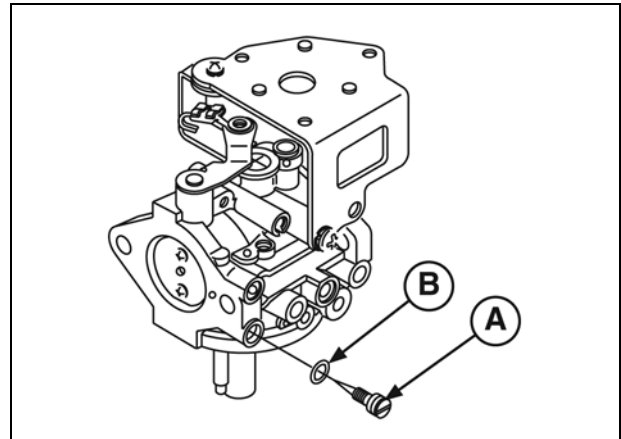

Figure 41

3. Install idle jet (A, Figure 42) and plug (B).

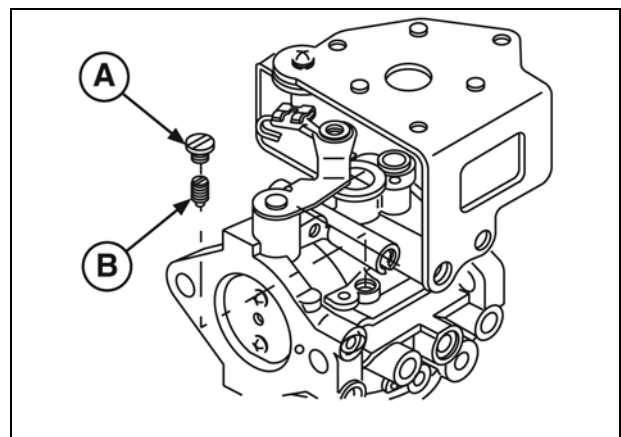

Figure 42

4. Assemble vacuum choke break (A, Figure 43) to bracket. Note correct position of pivot arm (B).

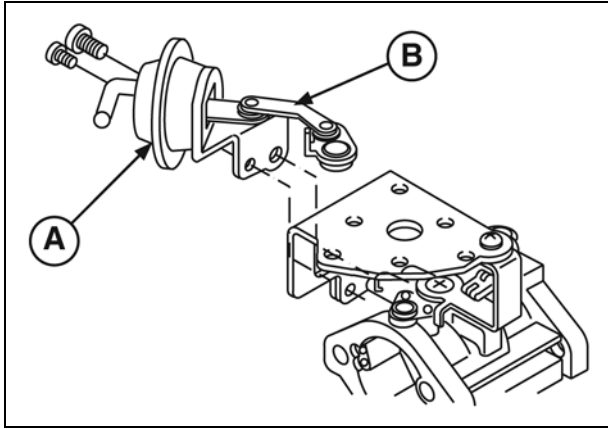

Figure 43

5. Install choke shaft through pivot arm bushing and into carburetor body (Figure 44).

NOTE: Specification between arms: 0.094 in. (2.5 mm).

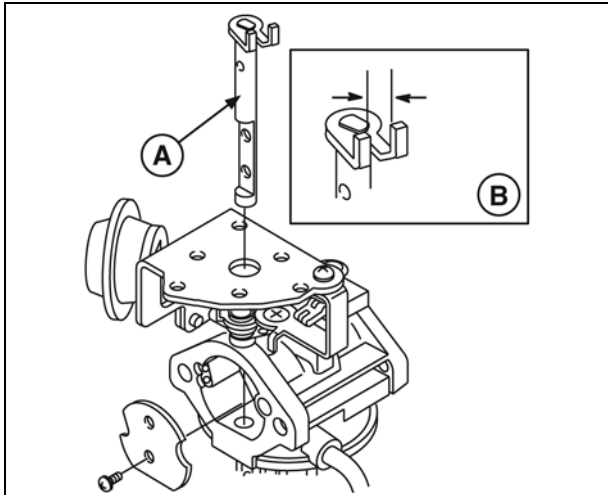

Figure 44

6. Install choke plate.
7. Install thermostat with new gasket (A, Figure 45).
8. Insert hook (B) on thermostat spring between arms on choke shaft.
9. Assemble thermostat retainer leaving screws loose.

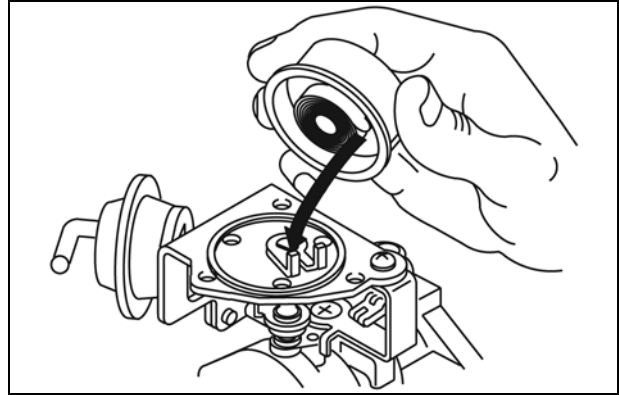

Figure 45

10. Hold choke plate closed and rotate thermostat until match marks are aligned (Figure 46). Tighten screws.

NOTE: Make sure choke plate remains closed while pre-loading thermostat spring.

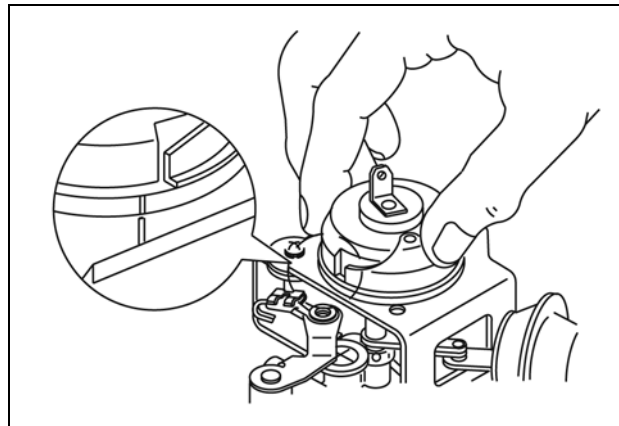

Figure 46

11. Assemble choke pre-load lever (A, Figure 47) to choke shaft.

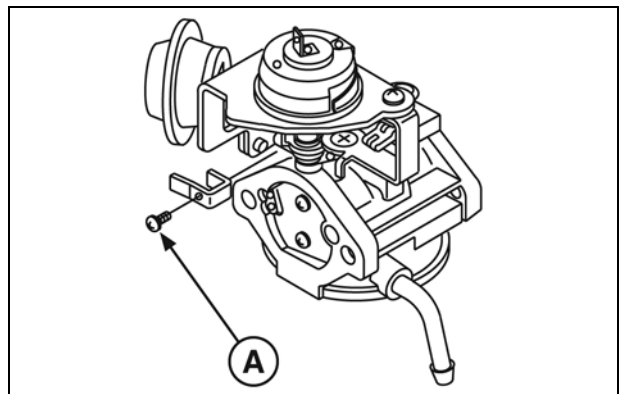

Figure 47

12. Install float. Assemble inlet valve to float (A, Figure 48).
13. Install float hinge pin (B), idle passage plug (C), fixed main jet with new gasket (D), and new bowl gasket (E).

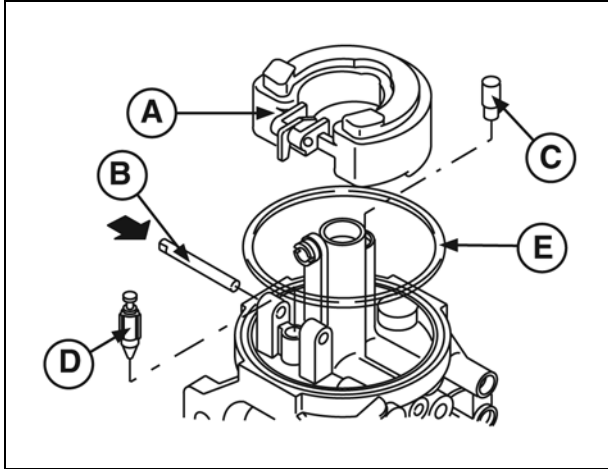

Figure 48

14. Install float bowl with new gaskets (Figure 49).

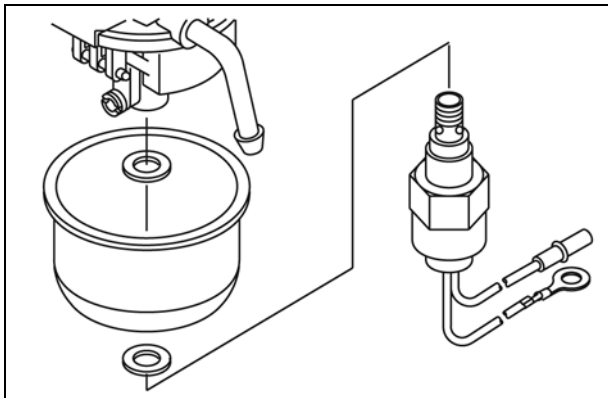

Figure 49

Check Vacuum Choke Break

A Mityvac® vacuum pump or equivalent is required when checking and adjusting the vacuum choke break.

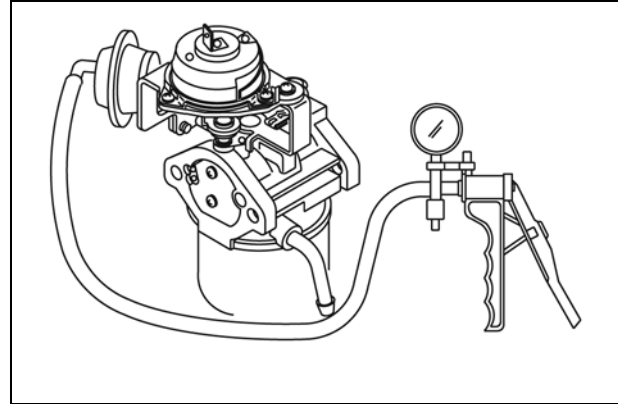

Figure 50

1. Connect vacuum pump to choke break and activate pump to specification shown.
 - Specification - 4.0 -5.5 in. Hg. vac. (10.0-14.0 cm. Hg. vac.).

Choke plate should partially open and pump gauge should maintain vacuum.

2. Check dimension from edge of choke plate to edge of carburetor throat (Figure 51).

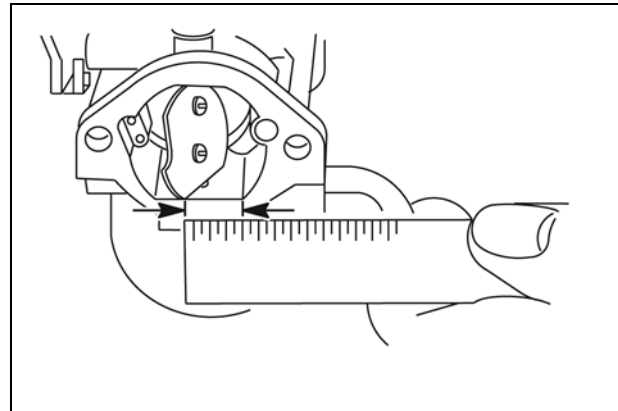

Figure 51

- Specification - 0.550-.590 in. (14.0-15.0 mm).

If dimension is not to specification, the choke pre-load lever must be adjusted.

Adjust Choke Pre-Load Lever

1. Release vacuum pump so that the choke closes.
2. Manually open choke to end of travel and hold in this position.
3. Carefully bend pre-load lever (A, Figure 52).
 - Bend lever to left in increase dimension (B).

- Bend lever to right to decrease dimension (C).
4. Recheck and adjust as necessary.

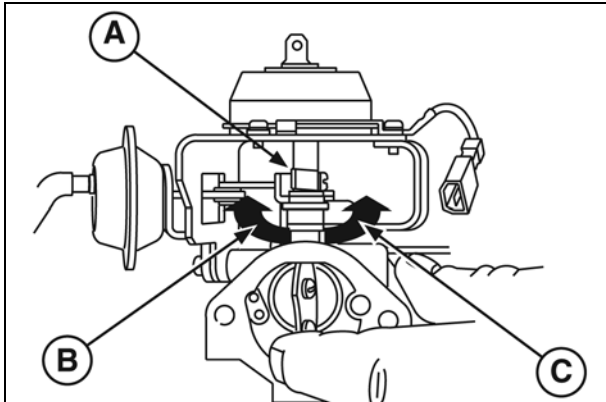

Figure 52

Check P.T.C. Heater

The Digital Multimeter # 19464 is required to test the P.T.C. heater.

1. Set the multimeter to the Ω position.
2. Check resistance between tab terminal on thermostat and ground wire as shown (Figure 53).
 - Specification - 2.0-4.0 Ω @ (70° F)
3. Replace thermostat if not to specification.

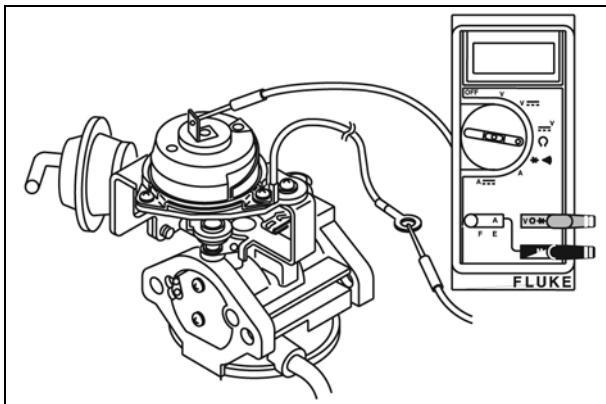

Figure 53

Install Carburetor

1. Assemble insulator with gaskets, carburetor and air horn to intake manifold.

NOTE: Attach thermostat ground wire (A, Figure 54) to air horn.

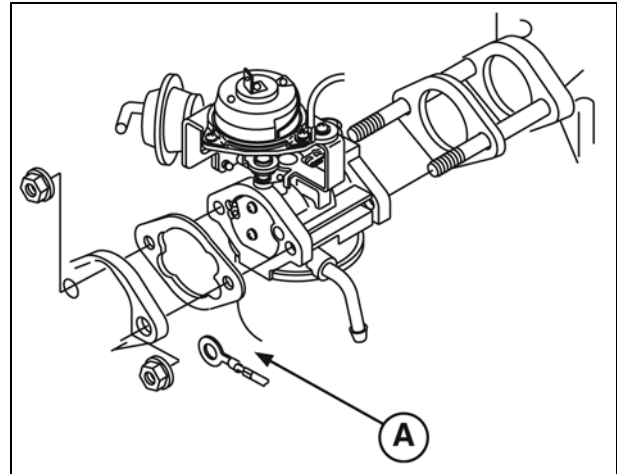

Figure 54

2. Torque nuts to specifications shown in Section 14 - Engine Specifications.
3. Install governor link and governor link spring.
4. Reinstall air cleaner tube, vacuum line, harness connectors, and fuel line.

Install Vacuum Limiter

To install a vacuum limiter on engines not originally equipped with one, proceed as follows:

1. Cut vacuum line approximately 2.0 in. (50 mm) from vacuum break side and install vacuum limiter with blue end facing intake manifold (Figure 55).

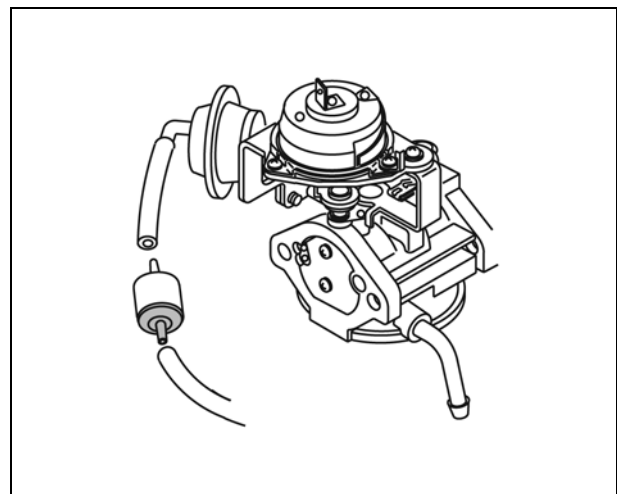

Figure 55

Initial Carburetor Adjustment

1. Turn idle mixture screw clockwise until it just seats. **DO NOT FORCE**. Turn screw counter-clockwise 1/2 turn (Figure 56). This setting will permit engine to start.

NOTE: Final adjustment will be made with engine running.

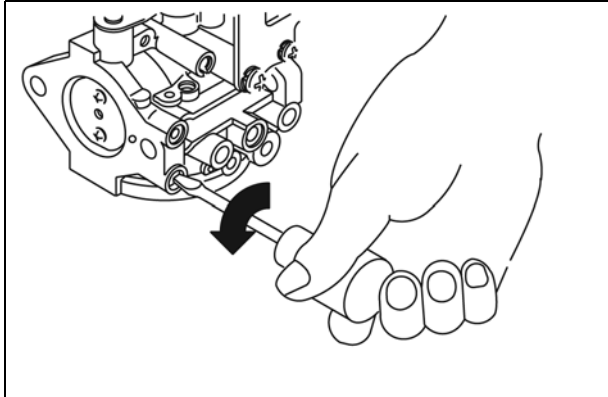

Figure 56

Final Carburetor Adjustment

NOTICE: All carburetor adjustments must be made with the air cleaner installed.

1. Start and run engine at low speed for approximately five minutes. Or, if equipped with a temperature gauge, until needle moves from C or COLD position.
2. With control lever on equipment in SLOW position, hold throttle lever (A, Figure 57) against idle speed screw and adjust idle speed to 1200 RPM.

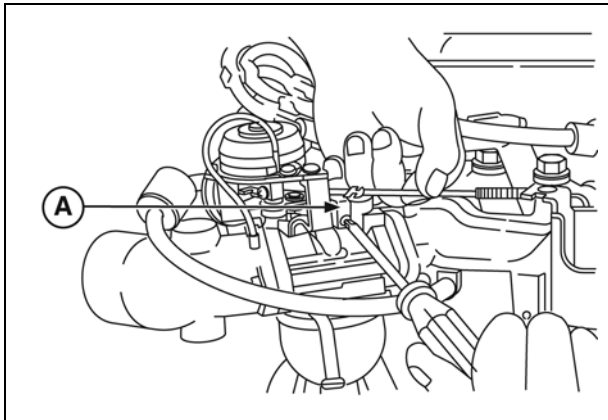

Figure 57

3. SLOWLY turn idle mixture screw clockwise until engine speed just starts to slow (lean mixture).
4. Then SLOWLY turn idle mixture screw counter-clockwise until engine speed just starts to slow (rich mixture).
5. Turn idle mixture screw to mid point between rich and lean (Figure 58).

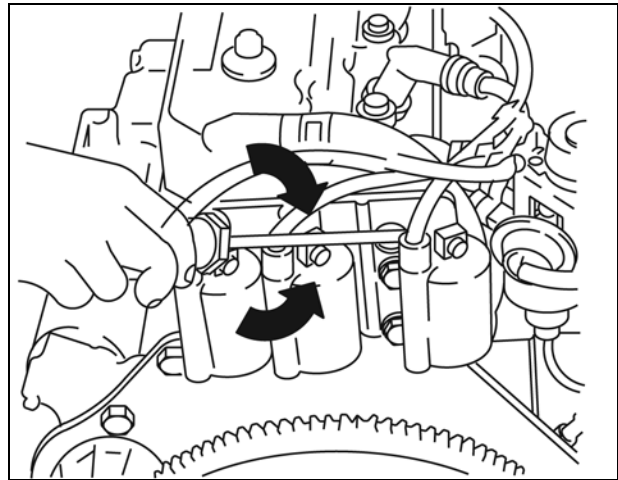

Figure 58

6. Hold throttle lever against idle speed screw and readjust idle speed to 1500 RPM, or equipment manufacturer's specification.

NOTE: If carburetor is equipped with an idle mixture limiter cap, install at this time.

7. Position limiter cap so that stop(s) on the limiter cap are at mid point between stop(s) on carburetor body and press into position.

Electric Fuel Pump

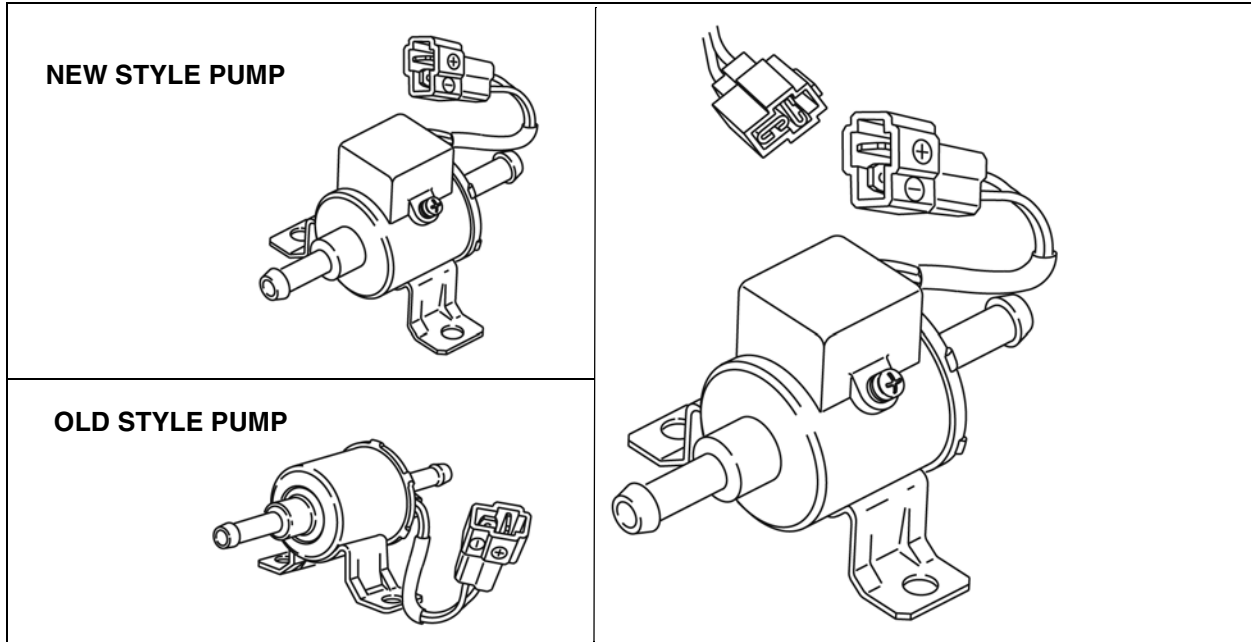

Check Fuel Pump Output

NOTE: A graduated container is required when testing the fuel pump.

1. Disconnect fuel line at carburetor.
2. Turn ignition switch to ON position and note fuel flow into graduated container.

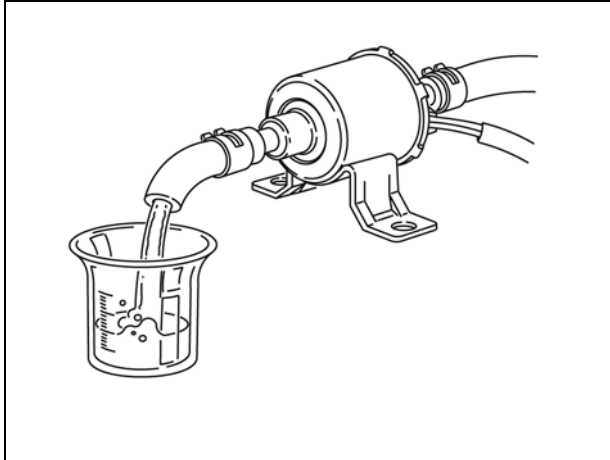

Figure 59

3. If fuel flow is less than specification, replace fuel pump.

NOTE: A plugged fuel filter and/or low battery voltage may cause insufficient fuel flow.

4. If there is no fuel flow when keyswitch is in ON position, check fuel pump wiring.

Test Equipment

The Digital Multimeter #19464 is required to test the fuel pump.

The fuel pump test will be performed with the meter in the V== (DC Volts) position (Figure 60).

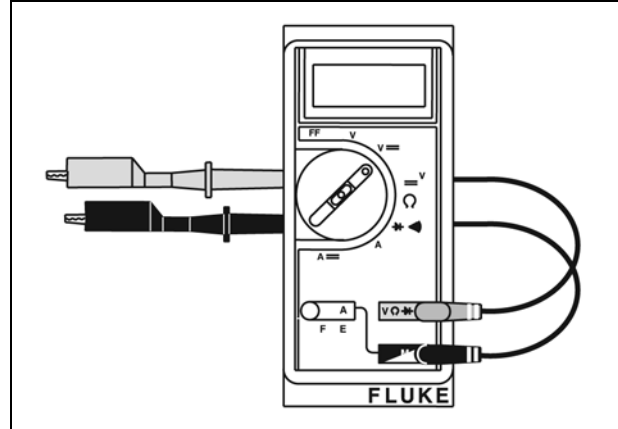

Figure 60

Test Fuel Pump Wiring

1. With keyswitch in OFF position, disconnect fuel pump equipment wiring harness connector.
2. Insert meter test leads into wiring harness connector (Figure 61).

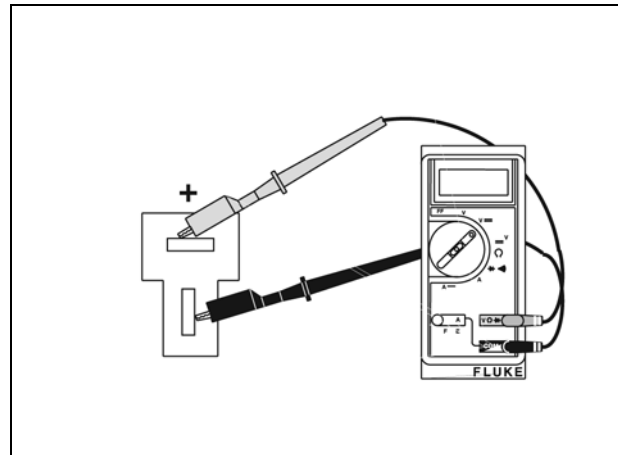

Figure 61

3. Turn the keyswitch to the ON position.
4. Meter should display battery voltage at connector.
5. If meter does not display battery voltage, problem is with wiring harness and/or fuel pump relay (as supplied by equipment manufacturer), and/or ignition module. Check for loose or broken wires.

Anti-Afterfire Solenoid

Some carburetors are equipped with an anti-afterfire solenoid controlled by the equipment ignition switch. When the equipment switch is in the OFF position, the solenoid valve plunger closes, stopping fuel flow through the fixed main jet or high speed nozzle. When the switch is in the ON and START position, the solenoid valve opens, allowing normal fuel flow. The solenoid is operating properly if a click is heard when equipment ignition switch is turned ON and OFF. If solenoid is not working (defective solenoid or equipment wiring), the engine will not start or run.

NOTE: Anti-afterfire solenoid requires a minimum of 9 volts DC to function.

NOTICE: Engines equipped with an anti-afterfire solenoid are equipped with an air horn gasket with a ground clip imbedded in the gasket (A, Figure 62). An Anti-afterfire solenoid will not function if ground clip is removed or damaged.

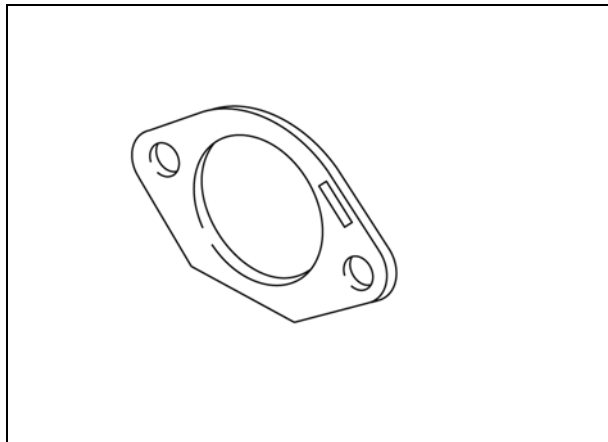

Figure 62

Test Anti-Afterfire Solenoid

If solenoid does not click, the problem may be in the equipment wiring. To determine whether the problem is with wiring, perform this test.

1. Set multimeter to the V== (DC volts) position (Figure 63).

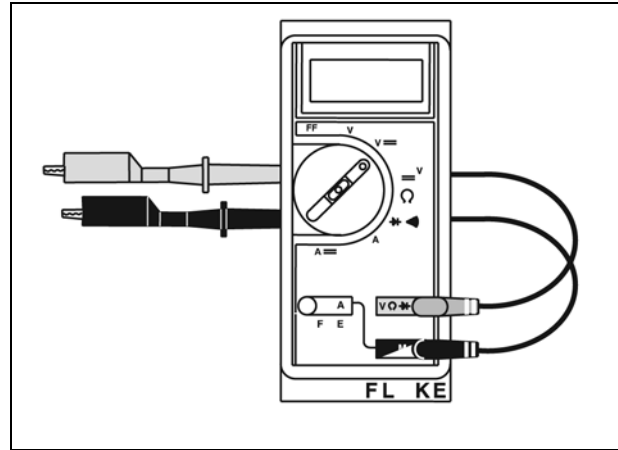

Figure 63

2. With keyswitch in OFF position, disconnect equipment wiring harness connector from solenoid.
3. Insert red meter test lead into wiring harness connector and attach black test lead to ground (Figure 64).

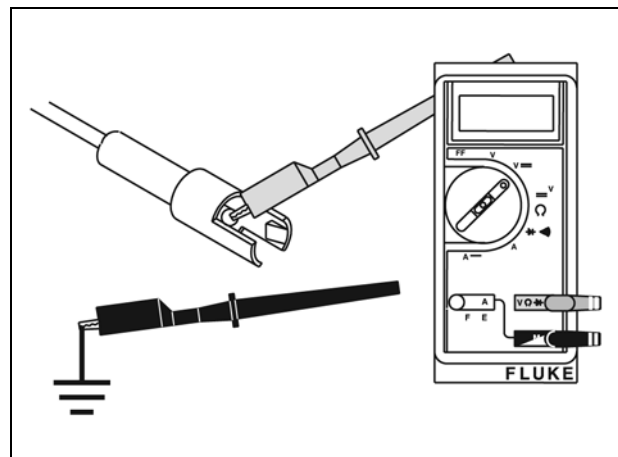

Figure 64

4. Turn keyswitch to ON position.
5. Meter should display battery voltage at connector. Test solenoid.
6. If meter does not display battery voltage, problem is with wiring harness, Check for loose or broken wires.

Test Solenoid

1. Remove solenoid from carburetor.
2. Place either terminal of a 9 volt transistor battery on the solenoid connector and other terminal on body of solenoid or ground wire (Figure 65).
3. Plunger should retract freely.

4. When battery is removed, plunger should return freely.
5. Replace solenoid if plunger sticks or doesn't move.

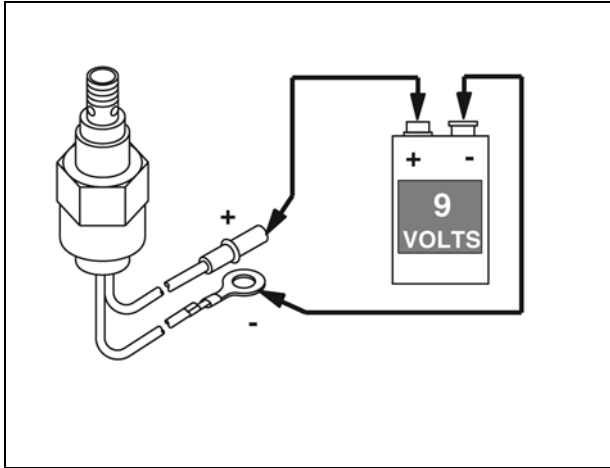

Figure 65

Carburetor Main Jets

The carburetor main jet orifice size is stamped in the body of the jet (Figure 67).

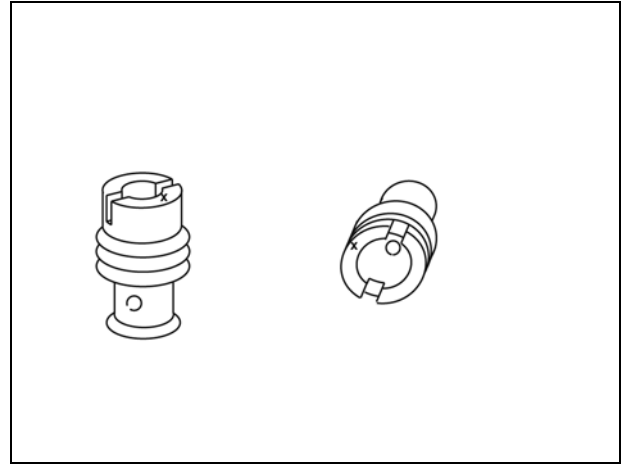

Figure 67

Fuel Filter

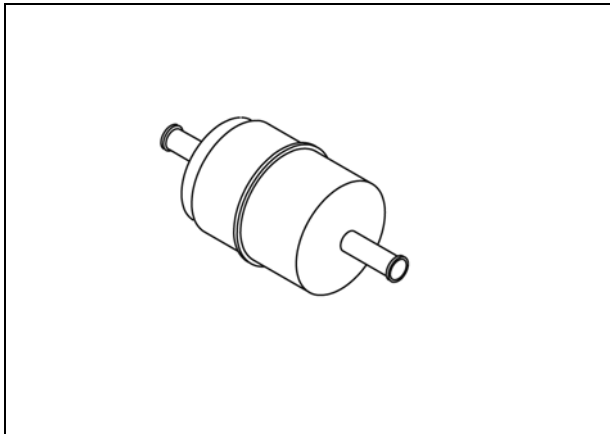





Figure 66

- Replace in-line fuel filter every 600 hours.
- In-line fuel filter has an arrow to indicate fuel flow direction, Always install arrow towards carburetor.

ELECTRONIC FUEL INJECTION (EFI) SYSTEM

	WARNING
	The EFI fuel system remains under high pressure, even when the engine has stopped.
	Failure to release pressure before servicing could result in fire or explosion.
<ul style="list-style-type: none">• Before attempting to service any part of the fuel system, the pressure must be relieved.• Remove the spark plug.• Disconnect negative battery cable.• Ensure the engine is cold.	

The EFI system controls two aspects of engine operation:

- The amount of fuel delivered to the engine
- The amount of ignition timing advance

The end result is optimum engine performance and maximum fuel economy while maintaining exhaust emission standards.

The Kiehn EFI system is equipped with an engine control unit (ECU) with a self-diagnostic function. If a malfunction in the system occurs, the ECU will identify the source and store the corresponding fault code(s).

A malfunction indicator lamp (MIL) will illuminate, indicating that the system needs service. The MIL will remain illuminated until the fault code(s) are read and the memory is reset.

The EFI system also employs a fail-safe function (limp home mode). If a major system malfunction were to occur, the engine would continue running at reduced capacity, based on parameters within the ECU, to prevent damage and avoid leaving the operator stranded.

NOTICE: If an abnormal crankshaft pulse is detected, the ECU will shut the engine down to prevent damage from occurring.

EFI Components

The system includes the following components:

- Air Temperature Sensor
- Crankshaft Position Sensor
- Crankshaft Reluctor Wheel
- Engine Control Unit (ECU)
- Engine Coolant Temperature Sensor
- Fuel Pump
- Fuel Filter
- Fuel Rail
- Fuel Injectors
- Heated Oxygen Sensor
- Ignition Coils
- Malfunction Indicator Light (MIL)
- Manifold Absolute Pressure (MAP) Sensor

Air Temperature Sensor

The air temperature sensor (Figure 1) provides continuous updates to the ECU on the air temperature entering the intake manifold. The ECU makes small corrections, based on certain temperature ranges, to increase or decrease the amount of fuel injected above the base injection time.

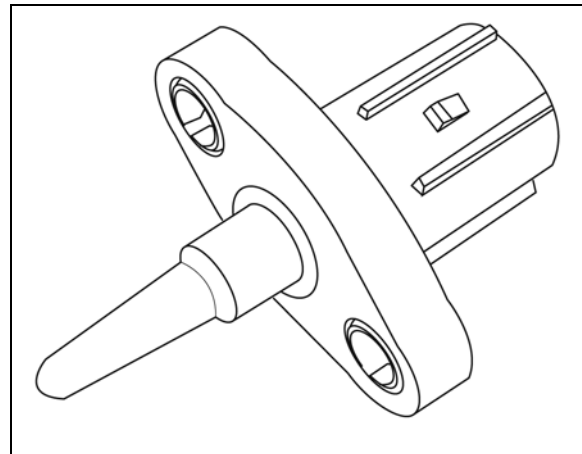

Figure 1

Crankshaft Position Sensor

The crankshaft position sensor (Figure 2) provides the ECU the signals needed to calculate RPM. This sensor controls the timing for the system to inject fuel as each intake valve opens, and controls when to apply voltage to the spark plug for the proper ignition-timing advance.

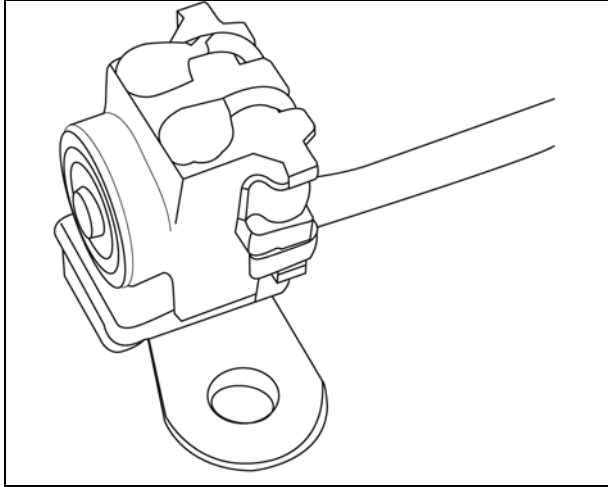

Figure 2

Crankshaft Reluctor Wheel

The reluctor wheel (Figure 3) is attached to the back of the crankshaft accessory drive pulley. This wheel works with the Crankshaft Position Sensor to provide a momentary interruption in the magnetic field, producing the voltage spike used by the ECU to determine RPM. The large gap in the reluctor wheel identifies top dead center on the number 1 cylinder. The ECU sequences through the firing order until the last injector has been opened.

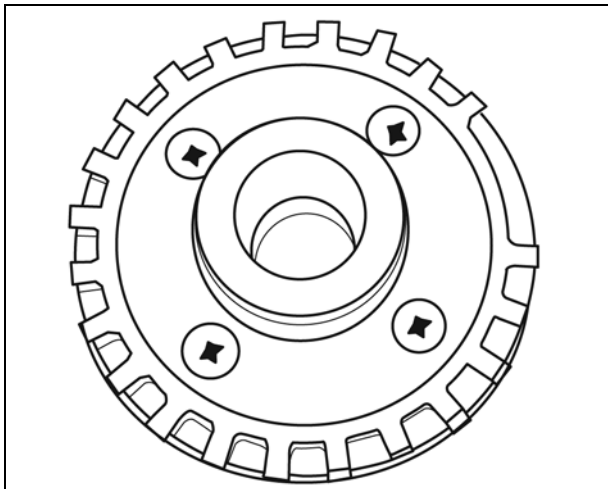

Figure 3

Engine Control Unit (ECU)

The Engine Control Unit (ECU) (Figure 4) collects information from the intake manifold pressure sensor, engine RPMs and various other sensors to determine the amount of compensation needed to the base injection time.

The ECU ensures the proper amount of fuel and ignition timing advance is delivered under various engine loads and RPMs. The fuel injection time is synchronized to the intake valve opening sequence.

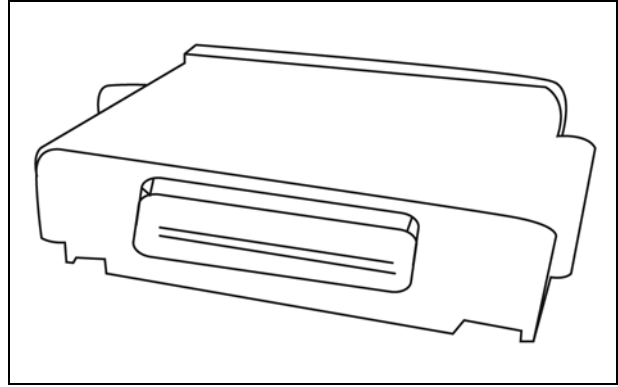

Figure 4

Engine Coolant Temperature Sensor

The coolant temperature sensor (Figure 5) provides the engine's current operating temperature to the ECU. Under cold start conditions, the ECU makes corrections to the base injection time to keep the injectors open longer, delivering more fuel during warm up.

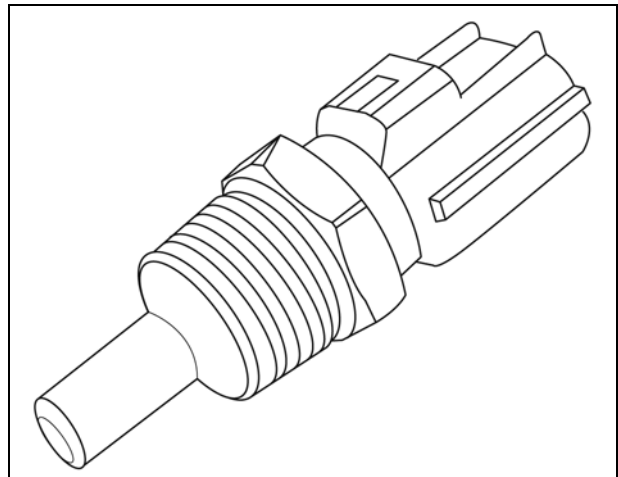

Figure 5

Fuel Pump

An electric fuel pump (Figure 6) transfers fuel in the EFI system. Depending on the application, the pump may be inside the fuel tank, or in the fuel line near the tank. Through a relay, the ECU activates the fuel pump to pressurize the system. The fuel pump remains on while the engine is running.

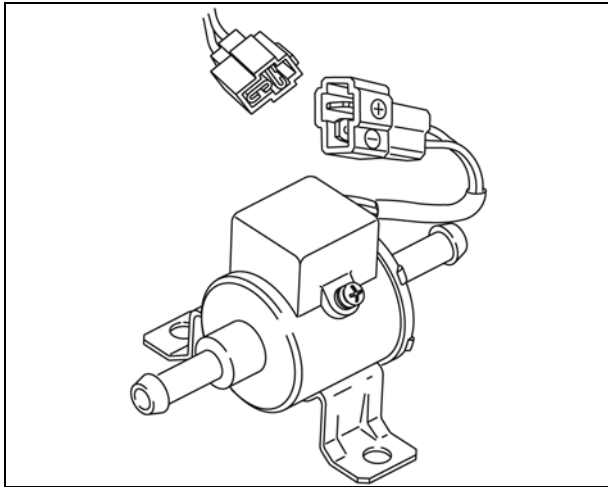

Figure 6

Fuel Filter

EFI engines use a high volume, high-pressure, in-line fuel filter (Figure 7).

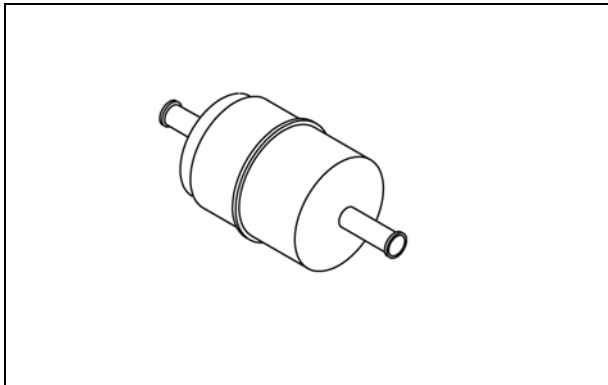

Figure 7

Fuel Rail

The fuel rail (Figure 8) is a formed tube assembly that feeds fuel to the top of the injectors. A valve in the rail allows for testing the operating pressure or relieving fuel system pressure when servicing. When the rail is assembled to the manifold, formed cups in the rail lock the injectors into place. A small retaining clip provides a secondary lock.

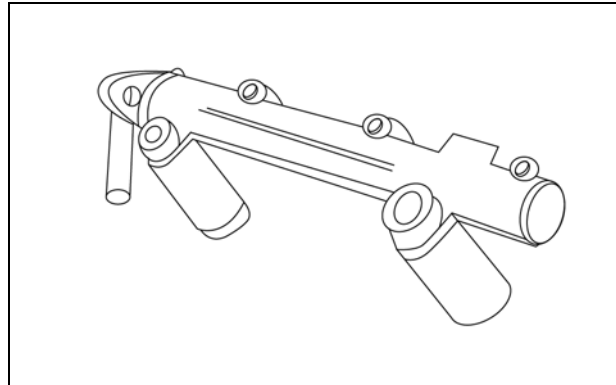

Figure 8

Fuel Injectors

The fuel injector (Figure 9) is an electromagnetic device that opens when voltage is delivered from the ECU. The longer the voltage is applied, the longer the injector will stay open. The injector sprays a fine mist of highly atomized fuel at the back of the intake valve through the intake port.

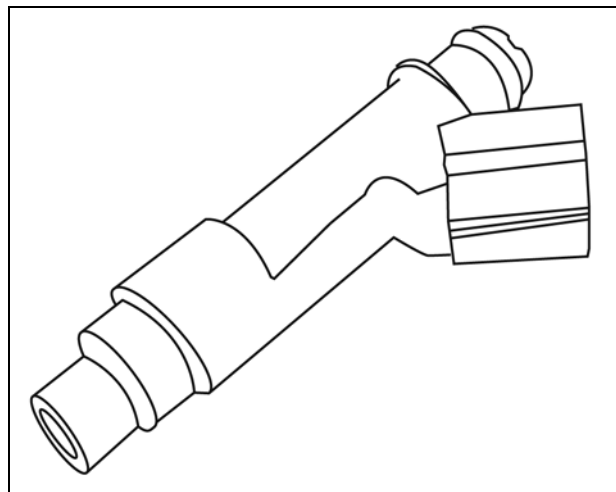

Figure 9

Heated Oxygen Sensor

The oxygen sensor (Figure 10) is the last in-line device to the ECU, providing information about the effectiveness of the ECU's output commands. The oxygen sensor is placed in the exhaust system to detect whether the engine is operating in a rich or lean state.

The sensor creates an electrical signal when it senses a difference in the level of oxygen in the exhaust compared to the outside atmosphere.

An integral heating element brings the sensor up to operating temperature quickly.

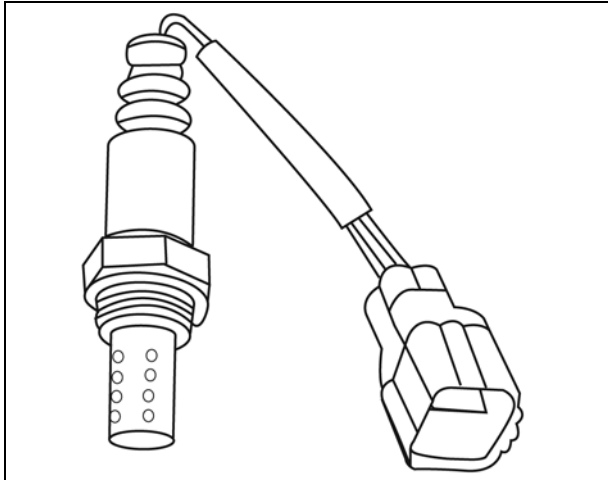

Figure 10

Ignition Coil

The ECU triggers the ignition coil (Figure 11) to fire, sending voltage to each spark plug when needed.

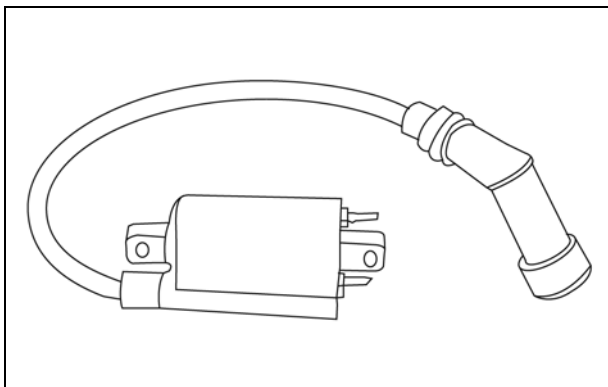

Figure 11

Malfunction Indicator Light (MIL)

If the self-diagnostic feature detects a fault, the fault code is displayed on the malfunction indicator lamp (MIL) (Figure 12) and is recorded in the ECU. The fault is stored until the memory is reset.

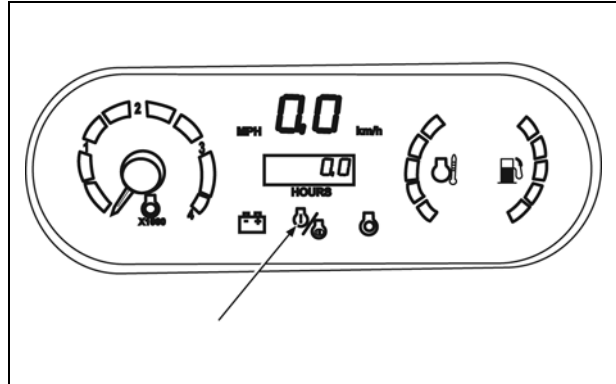

Figure 12

Manifold Absolute Pressure (MAP) Sensor

The manifold absolute pressure (MAP) sensor (Figure 13) measures the amount of vacuum in the intake manifold. This sensor uses a constant absolute pressure to eliminate the effects of changing atmospheric conditions.

The sensor uses a 5 volt input reference and, as pressure changes, it increases or decreases the amount of voltage returned to the ECU, which mathematically determines the engine load and regulates the amount of fuel to be injected.

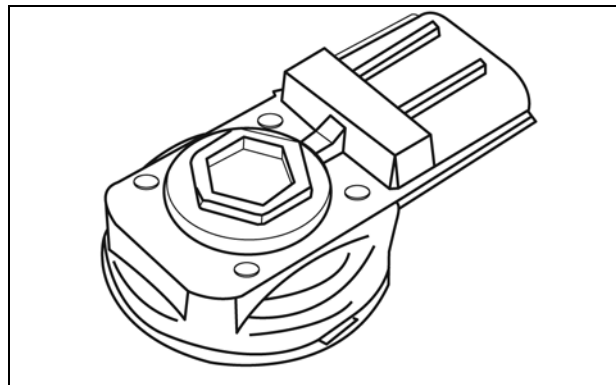

Figure 13

Troubleshooting

When troubleshooting an engine with EFI, basic engine operating problems must be addressed before turning to the EFI system components.

Engine starts hard or fails to start when cold

1. Fuel pump inoperative
2. Engine temperature sensor inoperative
3. Insufficient fuel pressure
4. Crankshaft position sensor inoperative
5. Crankshaft position sensor offset incorrect
6. Old/stale fuel
7. Low system voltage
8. Injectors clogged or restricted
9. Coils inoperative
10. Spark plugs fouled, worn, or damaged

Engine starts hard or fails to start when hot

1. Fuel pressure low
2. Fuel pump inoperative
3. Insufficient fuel pressure
4. Crankshaft position sensor inoperative
5. Crankshaft position sensor offset incorrect
6. Injectors clogged or restricted
7. Spark plugs fouled, worn, or damaged

Engine misses, hesitates, or stalls under load

1. Fuel injectors/fuel filter/fuel line dirty or restricted
2. Air cleaner dirty
3. Fuel pressure or fuel volume insufficient
4. Vacuum (intake air) leak
5. Governor setting incorrect
6. Spark plugs fouled, worn or incorrect gap
7. Plug wires loose or worn

Low Power

1. Air cleaner dirty
2. Fuel pressure insufficient
3. Governor setting incorrect
4. Exhaust system plugged or restricted
5. Injector(s) dirty or clogged































Electrical System

The EFI system is 12VDC with negative ground. A fully-charged 12 volt battery with a minimum of 350 cold cranking amps is required to maintain reliable system operation. Battery condition and state of charge should always be checked first when troubleshooting the EFI system.

EFI-related problems are more likely caused by the wiring harness or connections than by the EFI components. Even small amounts of corrosion or oxidation on the terminals can interfere with the milliamp currents used in system operation. Cleaning the connectors and grounds will solve problems in many cases.

If a fault code indicates a problem with an EFI component, disconnect the ECU connector and test for continuity between the component connector terminals and the corresponding terminals in the ECU connector.

FAULT CODES

FAULT CODE	COMPONENT	MIL Flashes	
		Long Flash	Short Flash
02	Crankshaft Position Sensor		
09	Intake Manifold Pressure Sensor		
12	Water Temperature Sensor		
13	Intake Air Temperature Sensor		
17	Oxygen Sensor		
24	Battery Voltage		
27	VCC Circuit		
33	Fuel Injector #1		
34	Fuel Injector #2		
35	Fuel Injector #3		
37	Ignition Coil #1		
38	Ignition Coil #2		
39	Ignition Coil #3		
41	Fuel Pump Relay		
45	Heated Oxygen Sensor		
58	Water Temperature Warning Lamp		

Fault Code on MIL Indicator

The MIL will display sequences of flashes that indicate a fault within the EFI system.

The number of flashes represents the number of the code.

For example, if there was an issue with battery voltage, the fault code 24 would be displayed on the MIL. This is represented by two long flashes followed by four short flashes, as shown below.

If more than one fault condition has occurred, a two-second pause will occur between each of the code flashes.

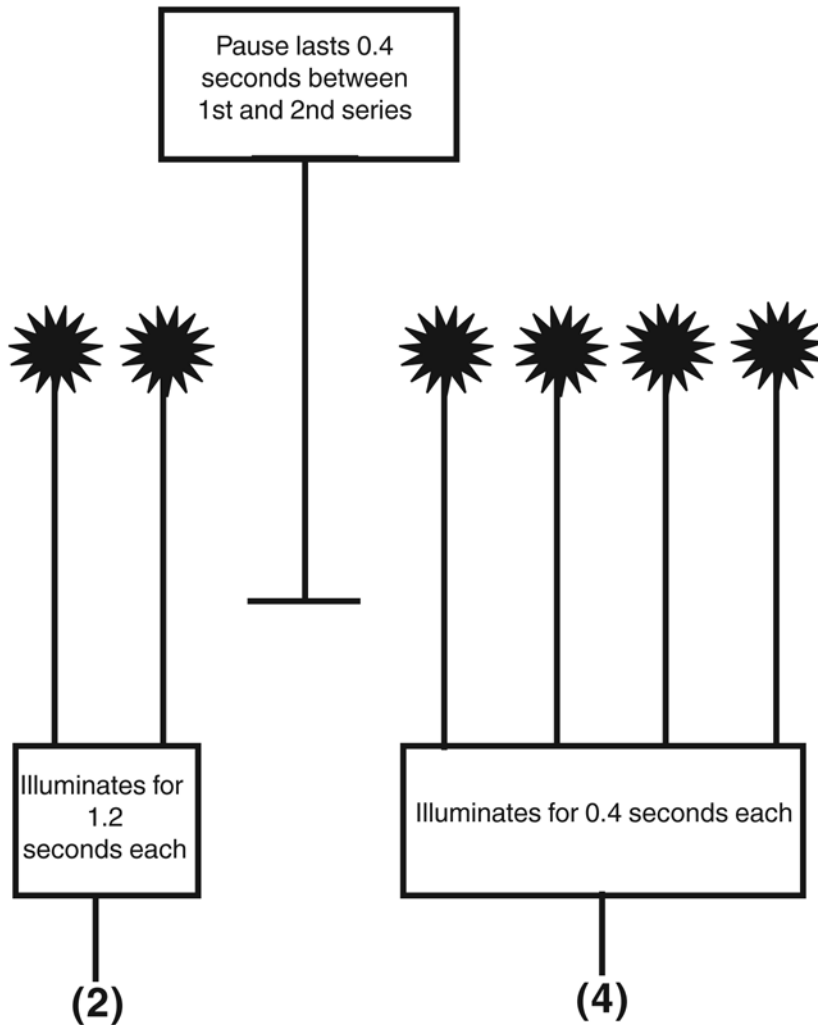

TROUBLESHOOTING ENGINE PERFORMANCE ISSUES

Black Smoke

10

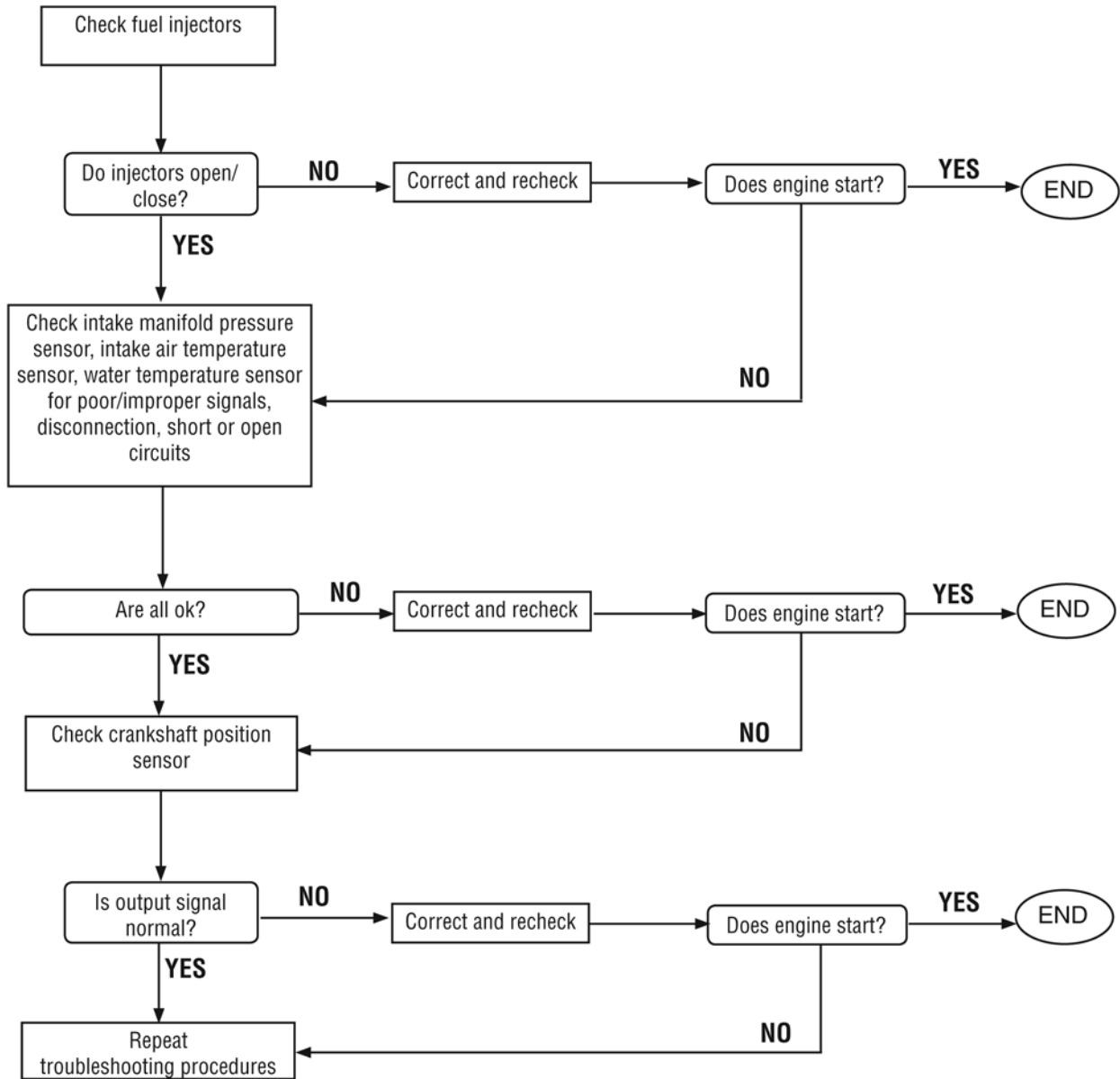

Detonation / Ping

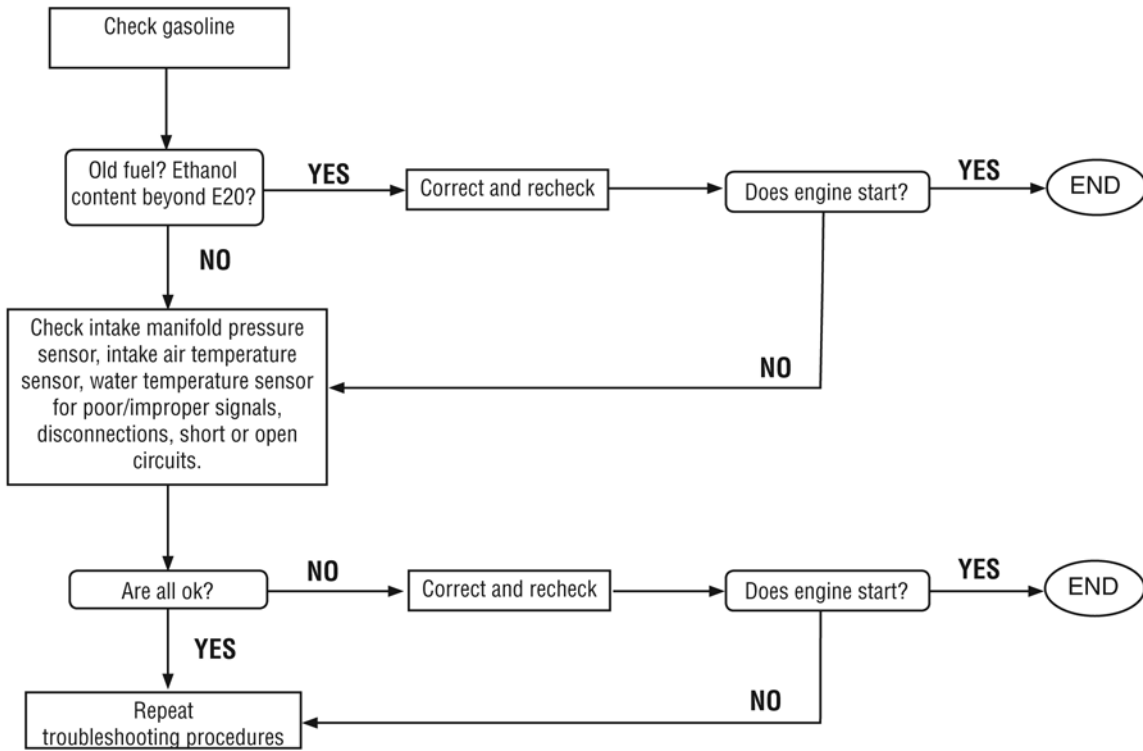

Engine Backfire / Afterfire

10

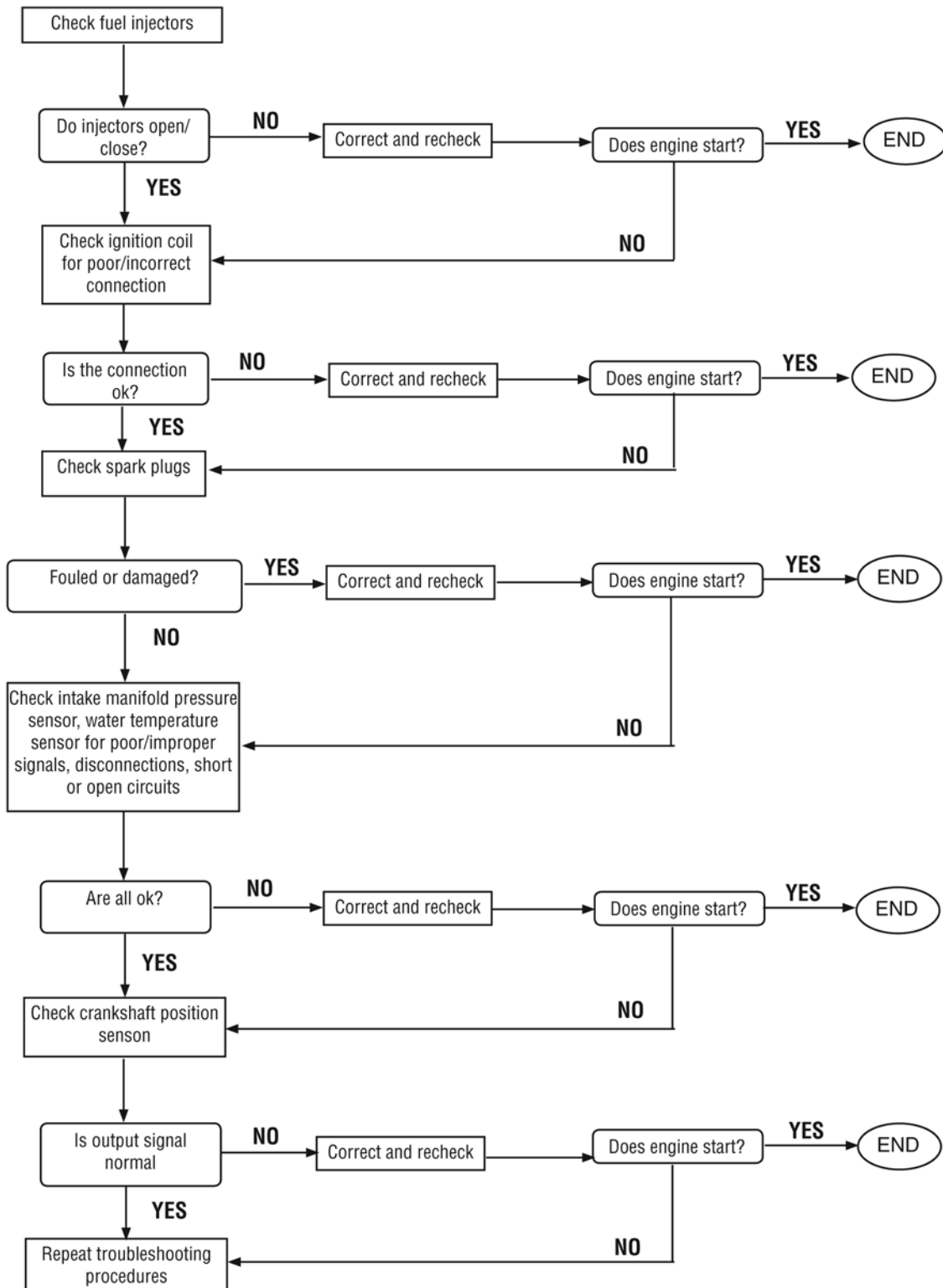

Engine Stalls During Acceleration

10

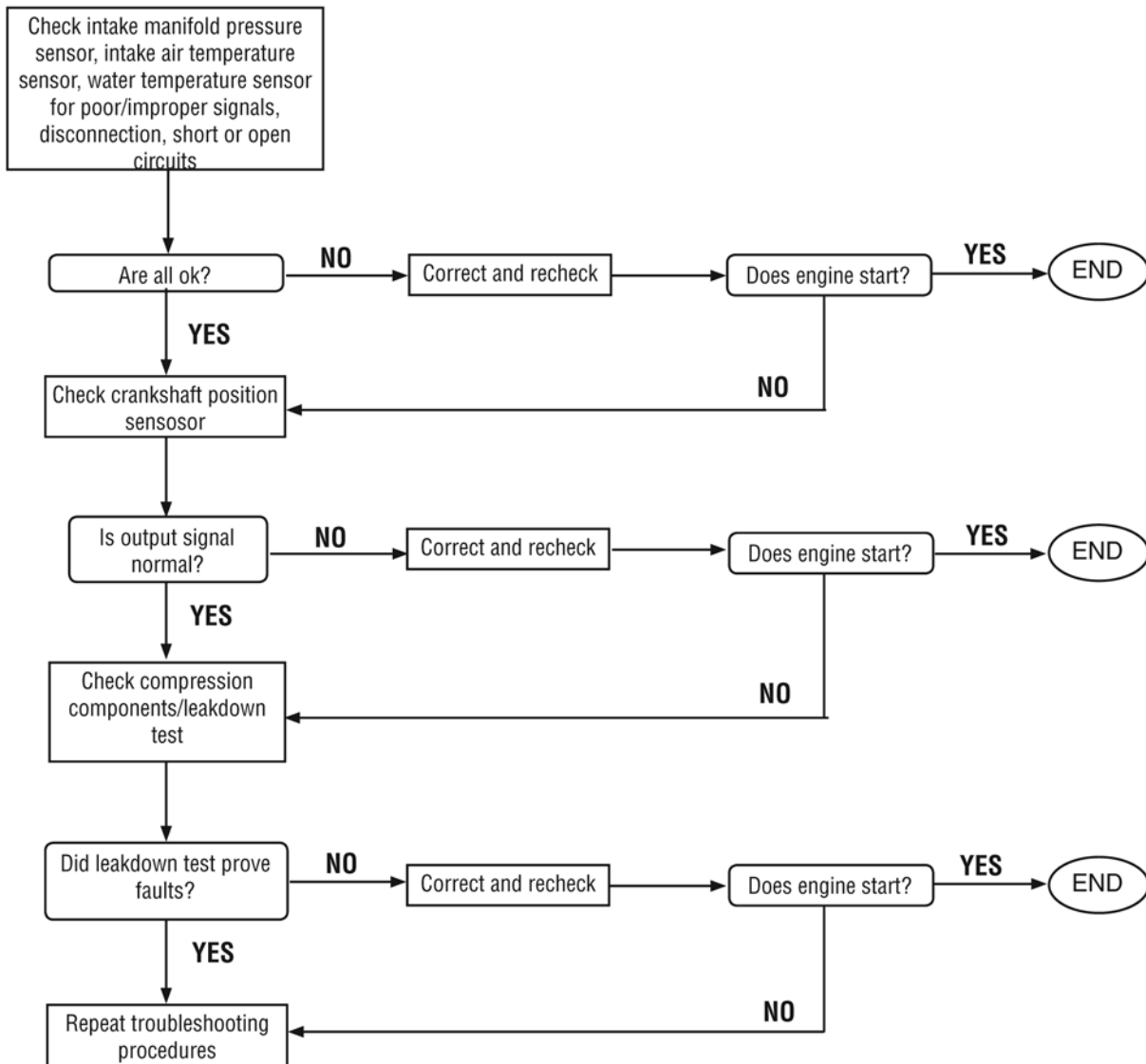

Engine Does Not Start

10

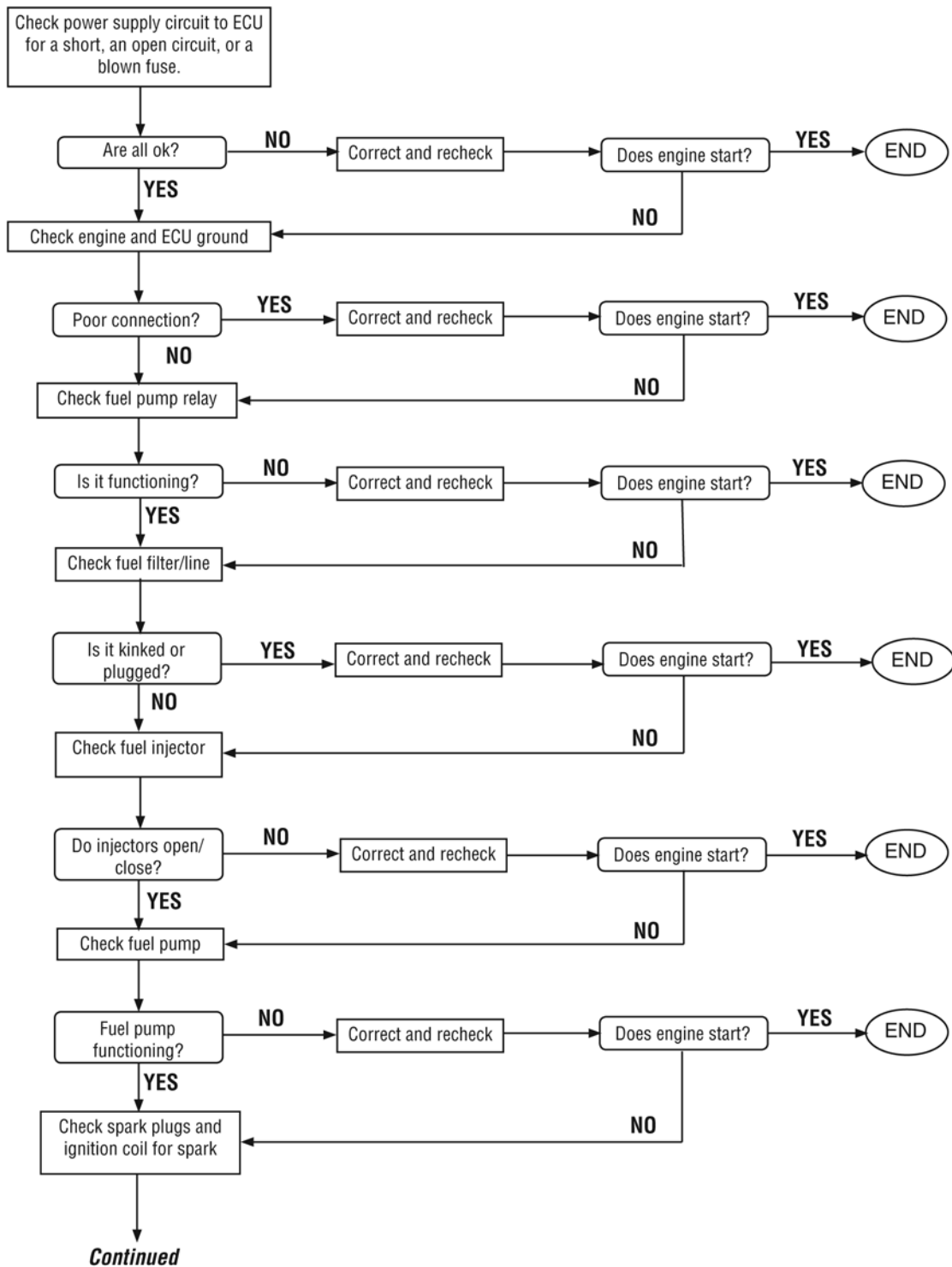

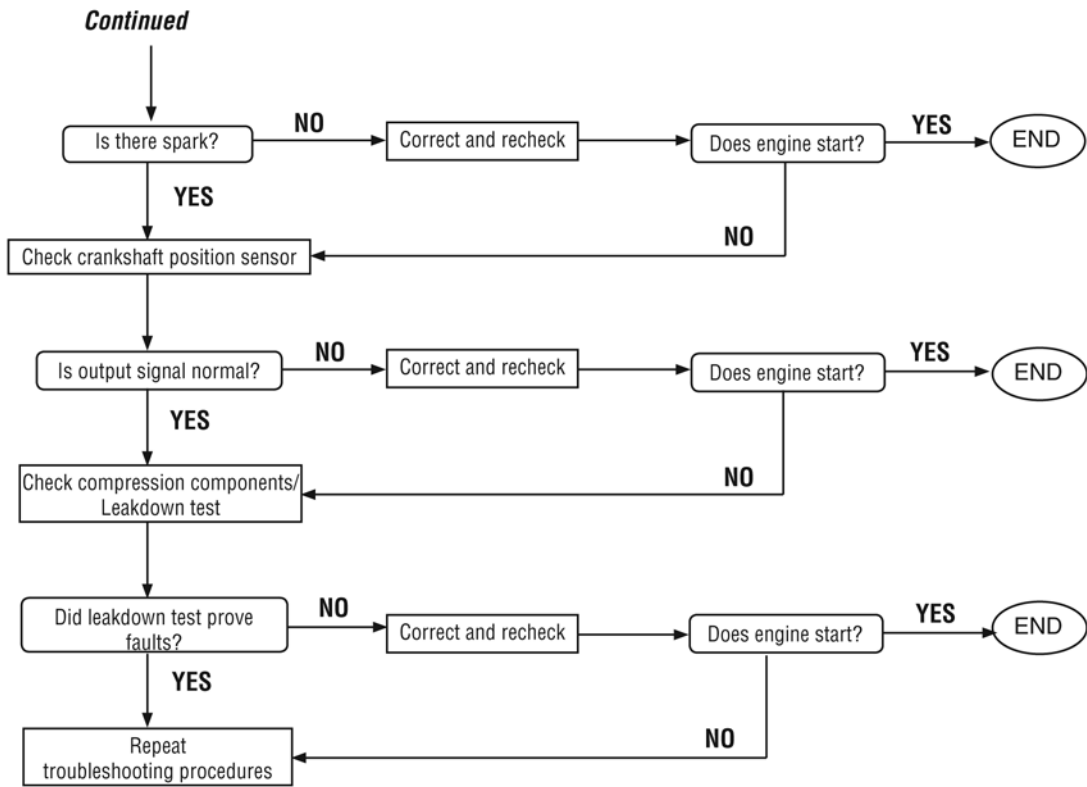

Engine Is Hard To Start

10

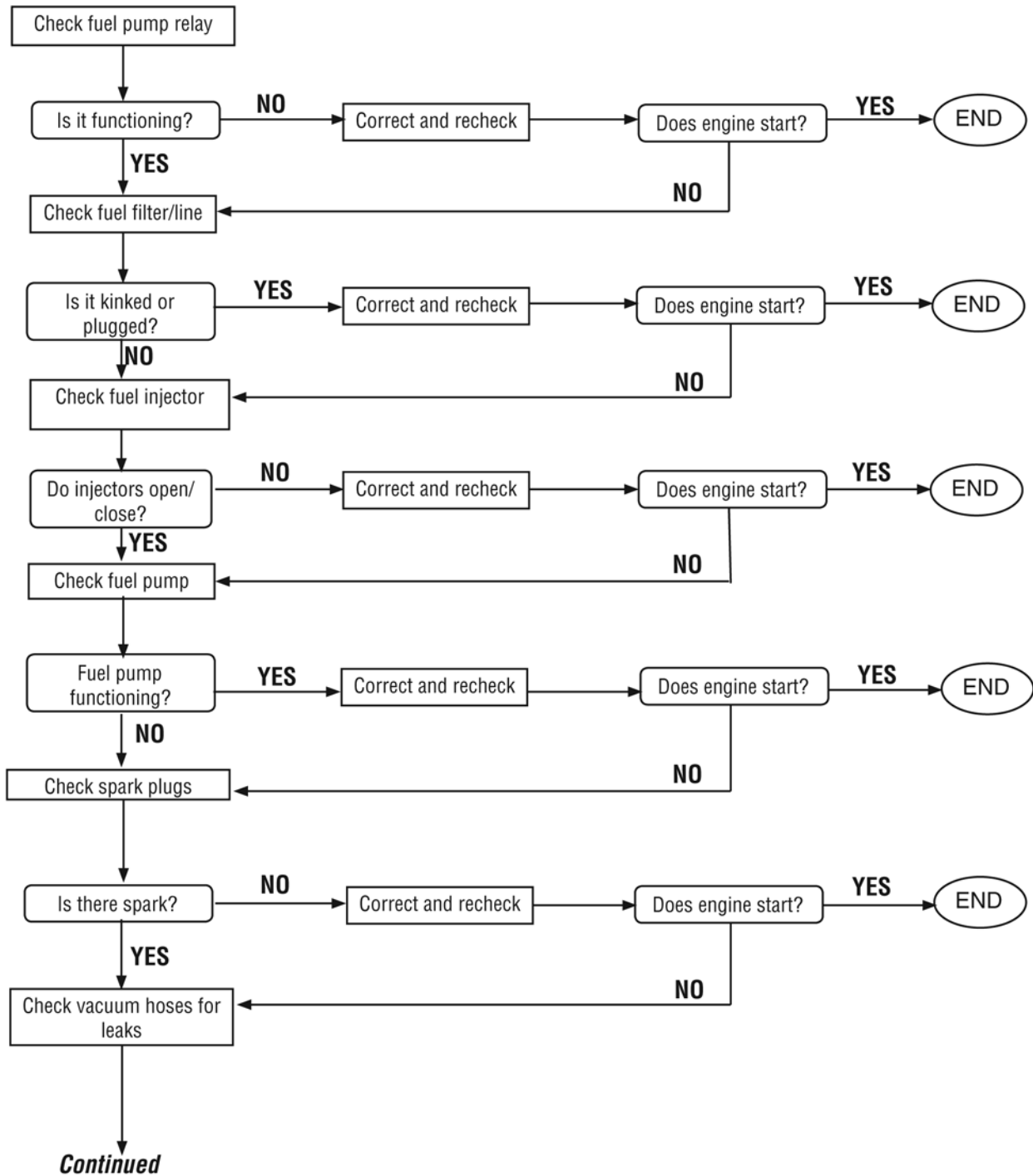

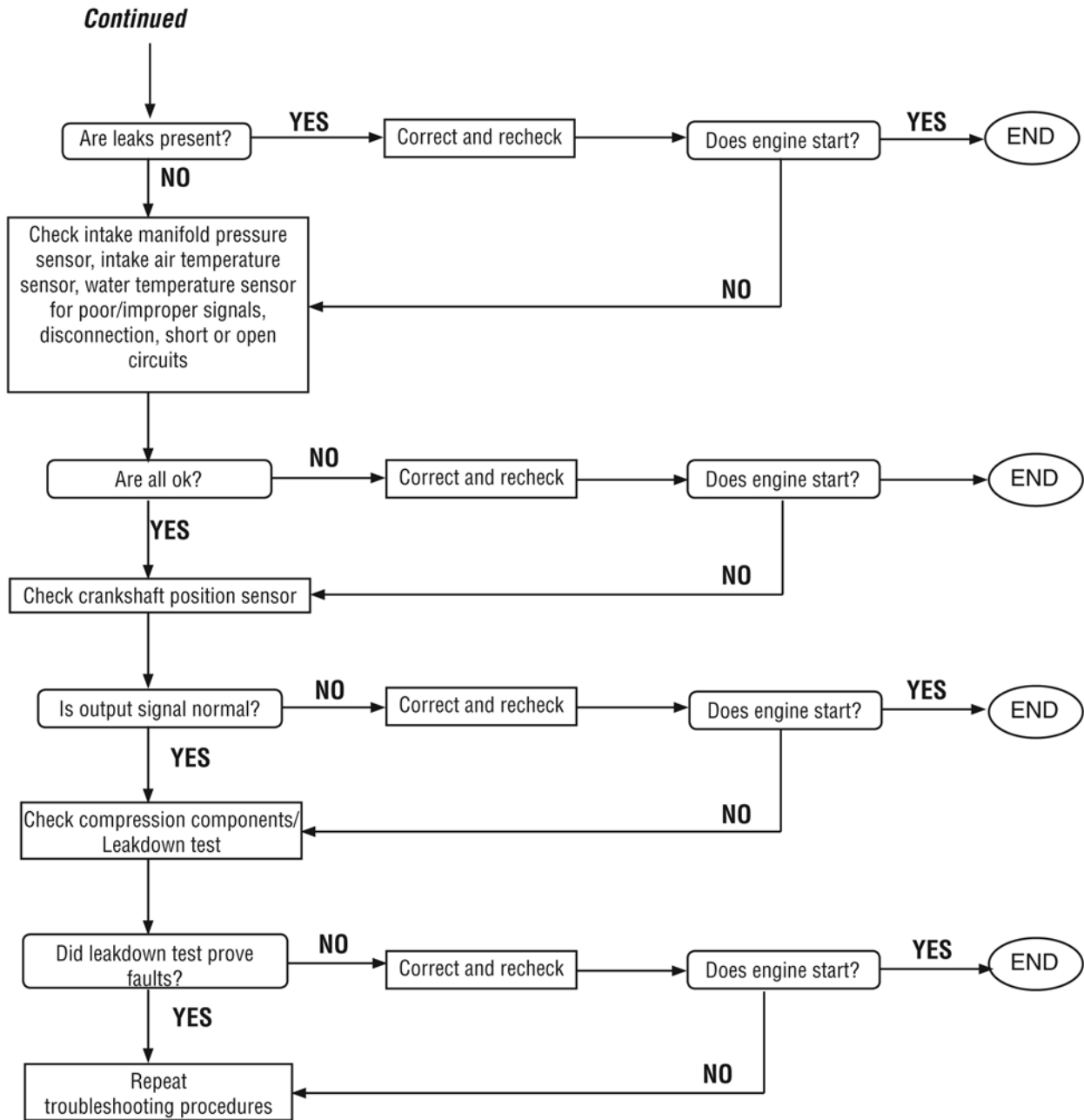

Hesitation During Acceleration

10

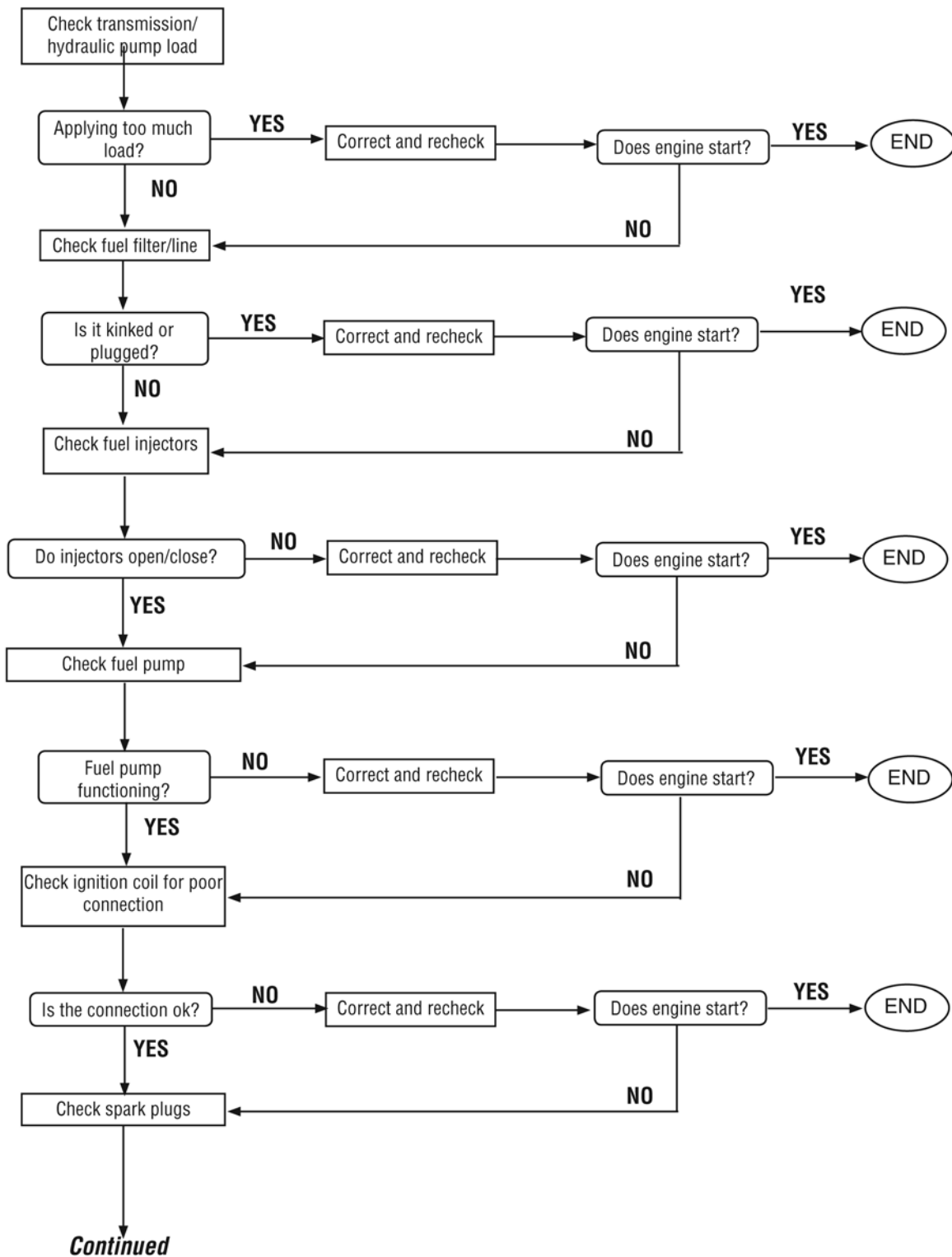

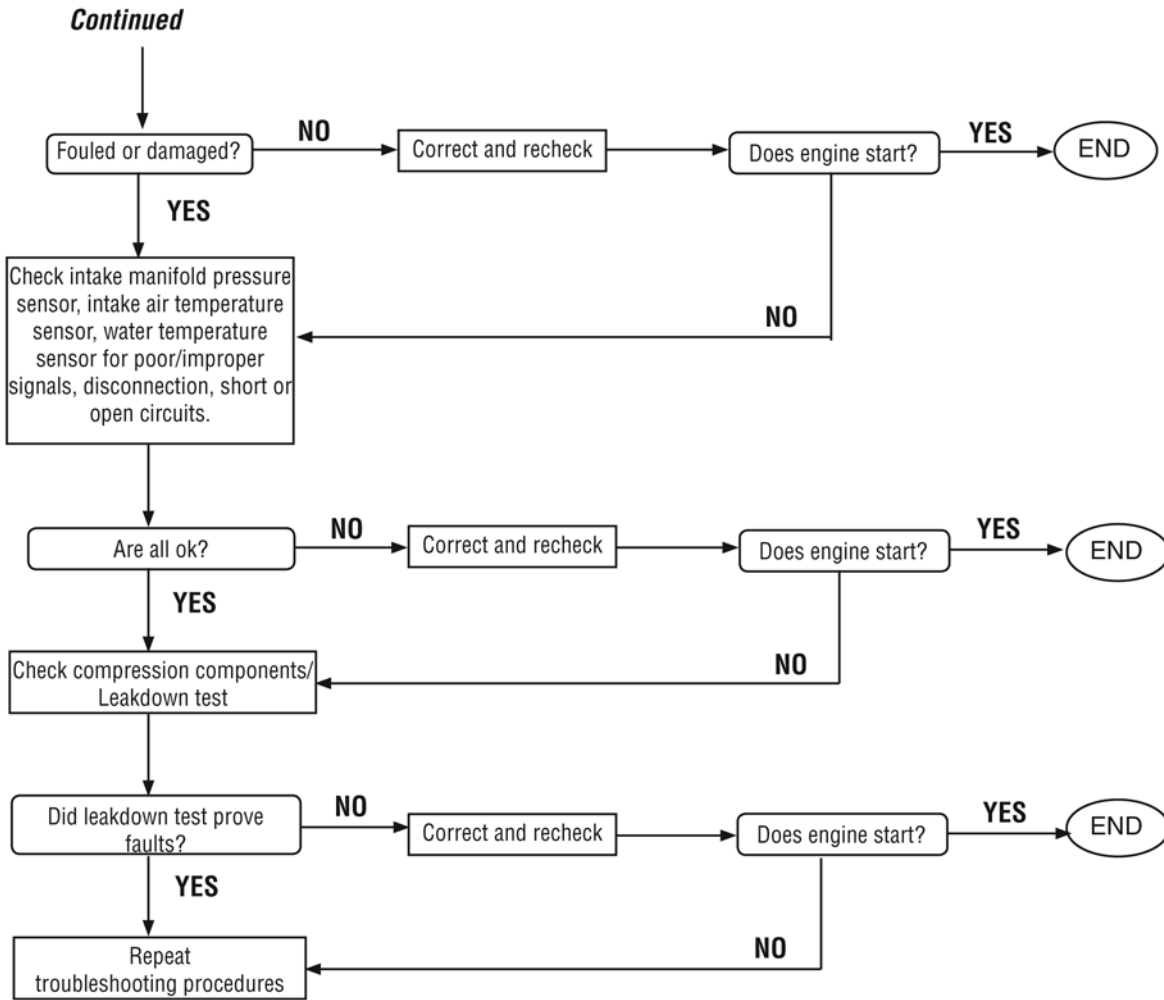

Low Power

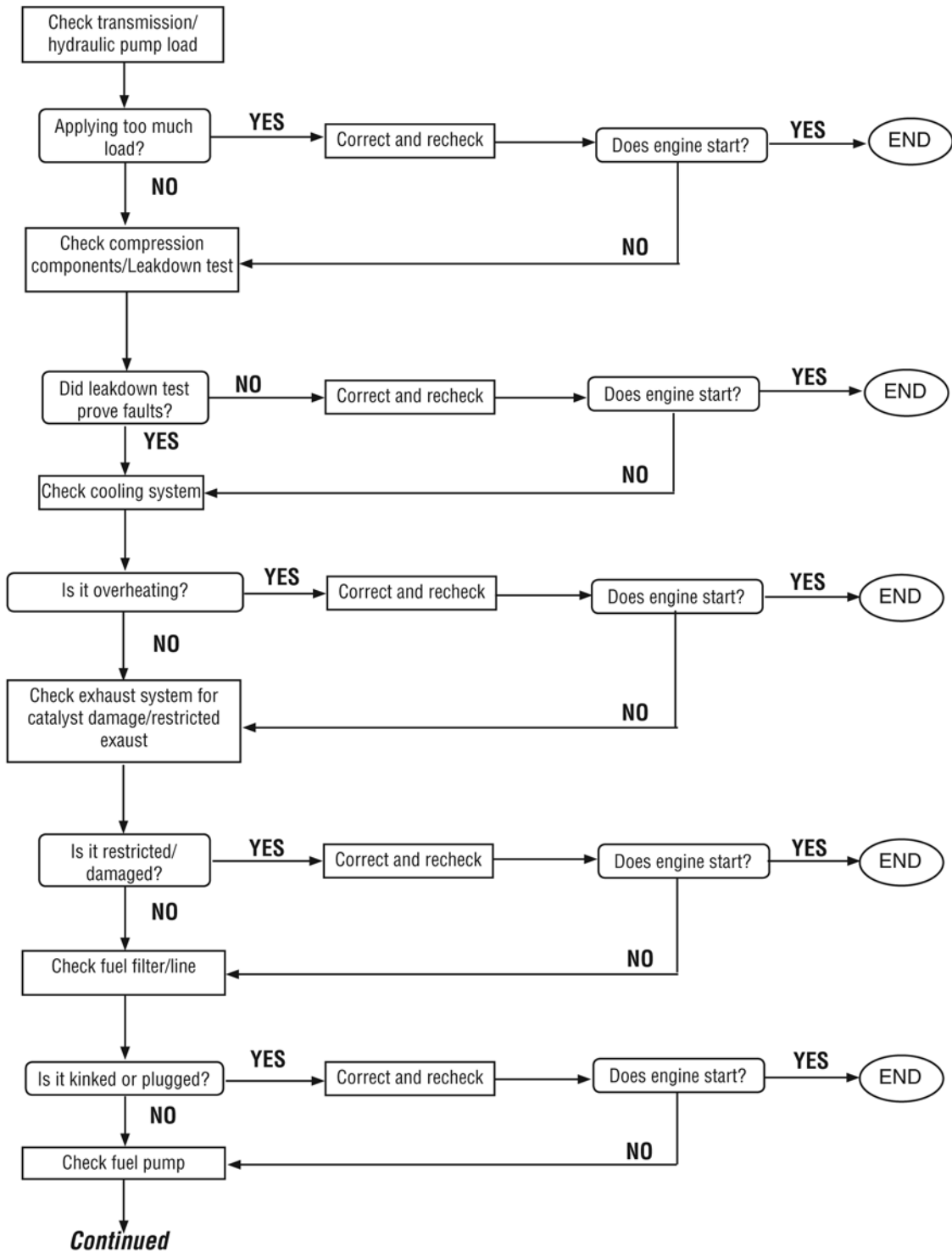

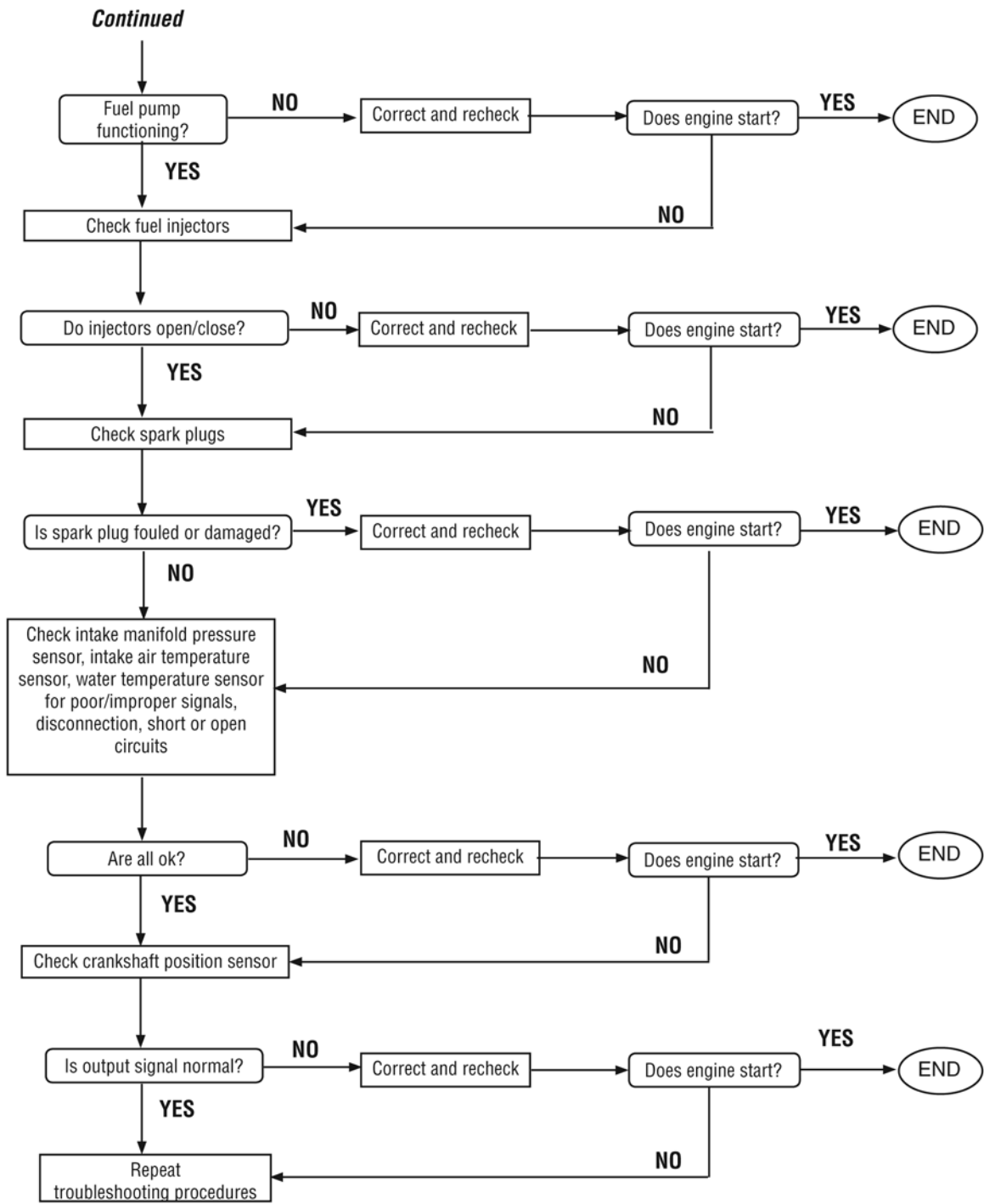

Idling Speed is Rough

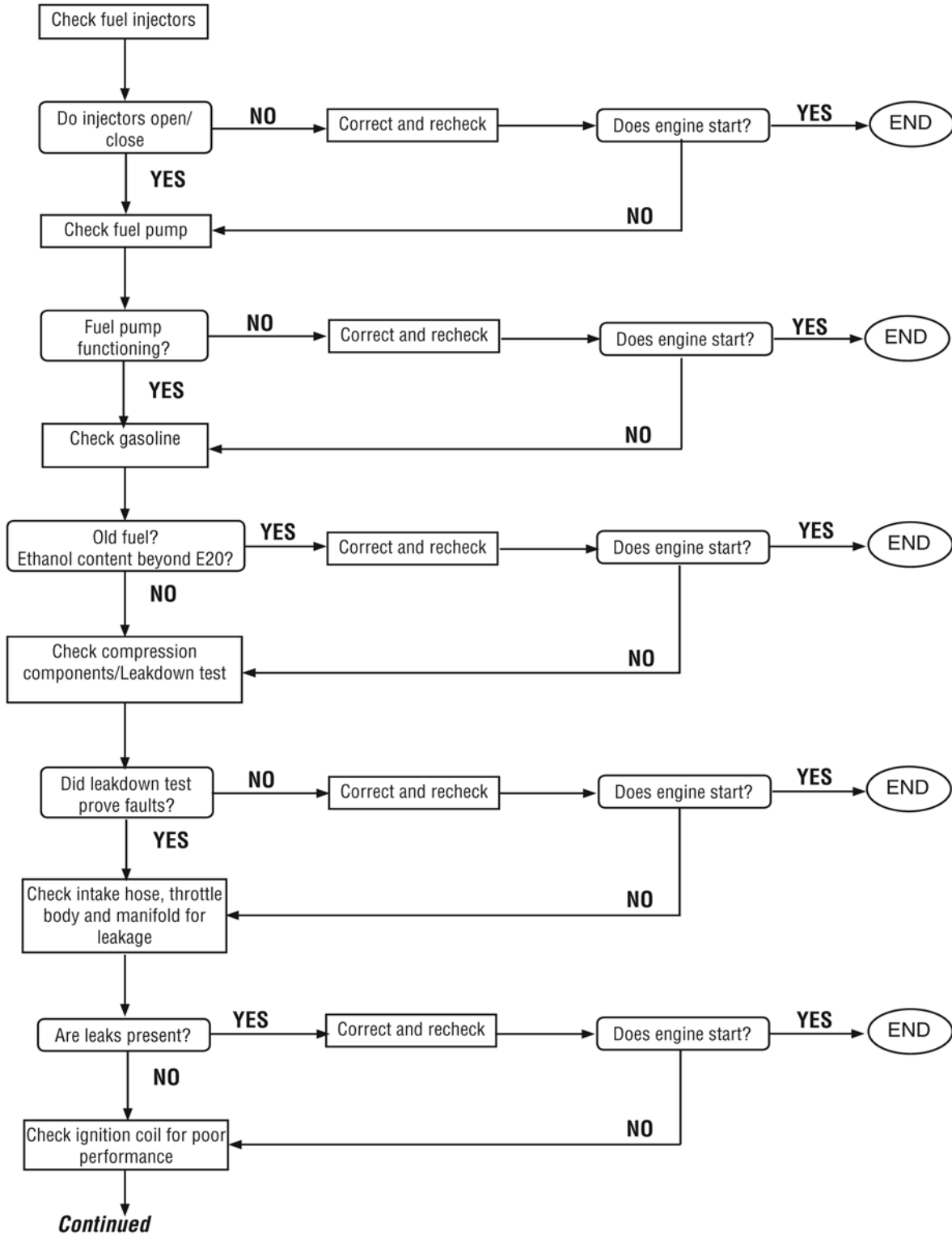

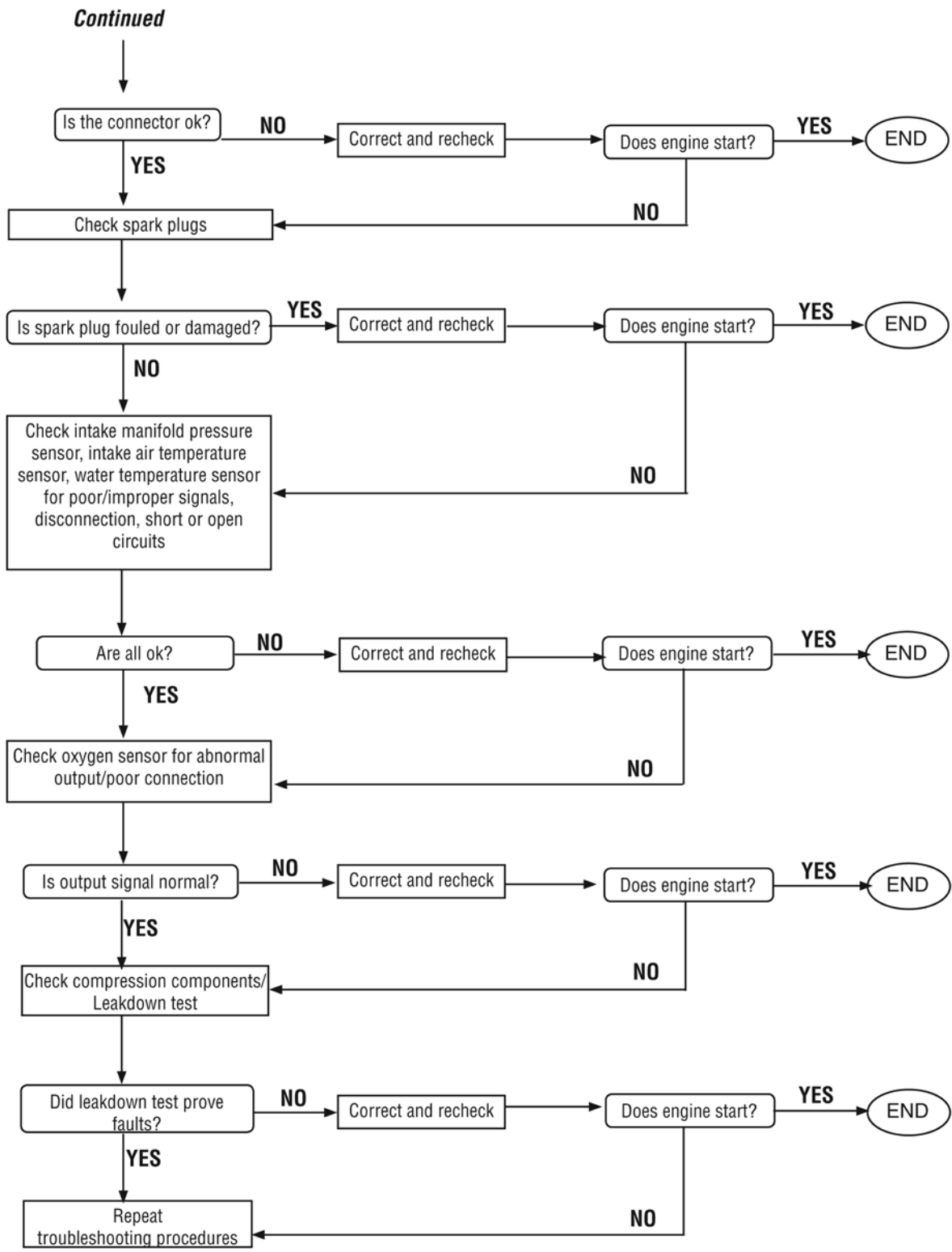

Hunting and Surging

10

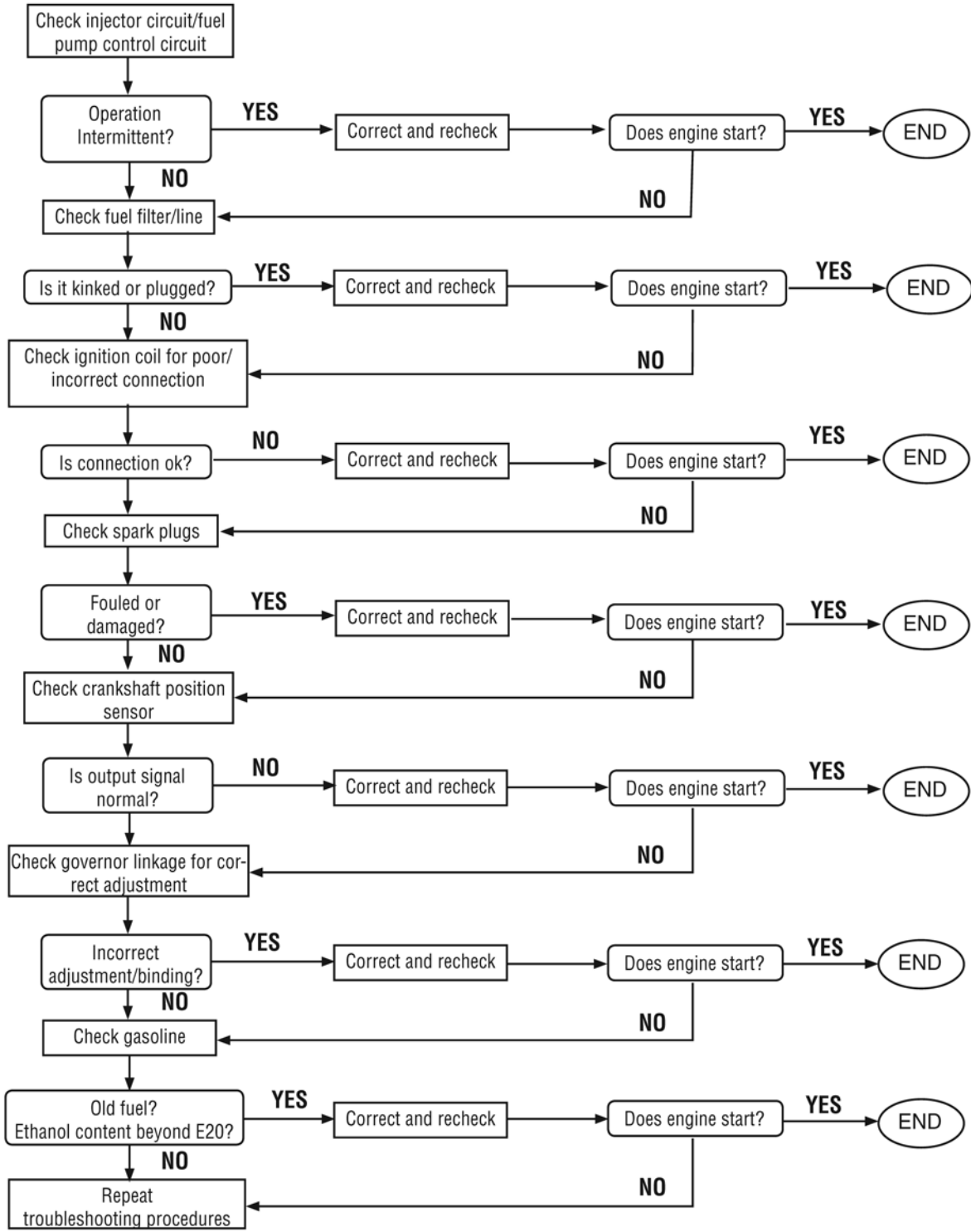

Hunting At Idle

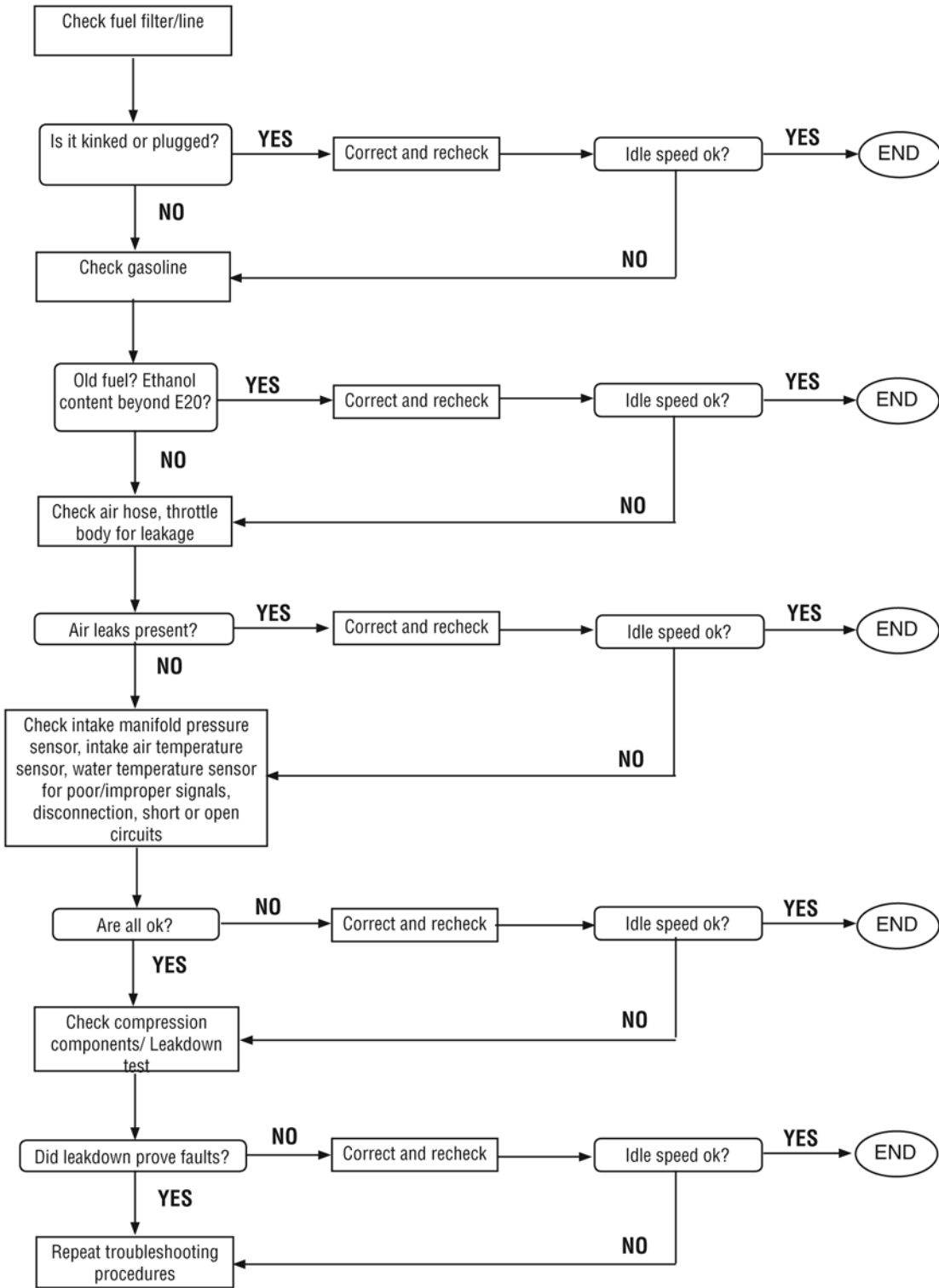

Engine Stalls at Idle

10

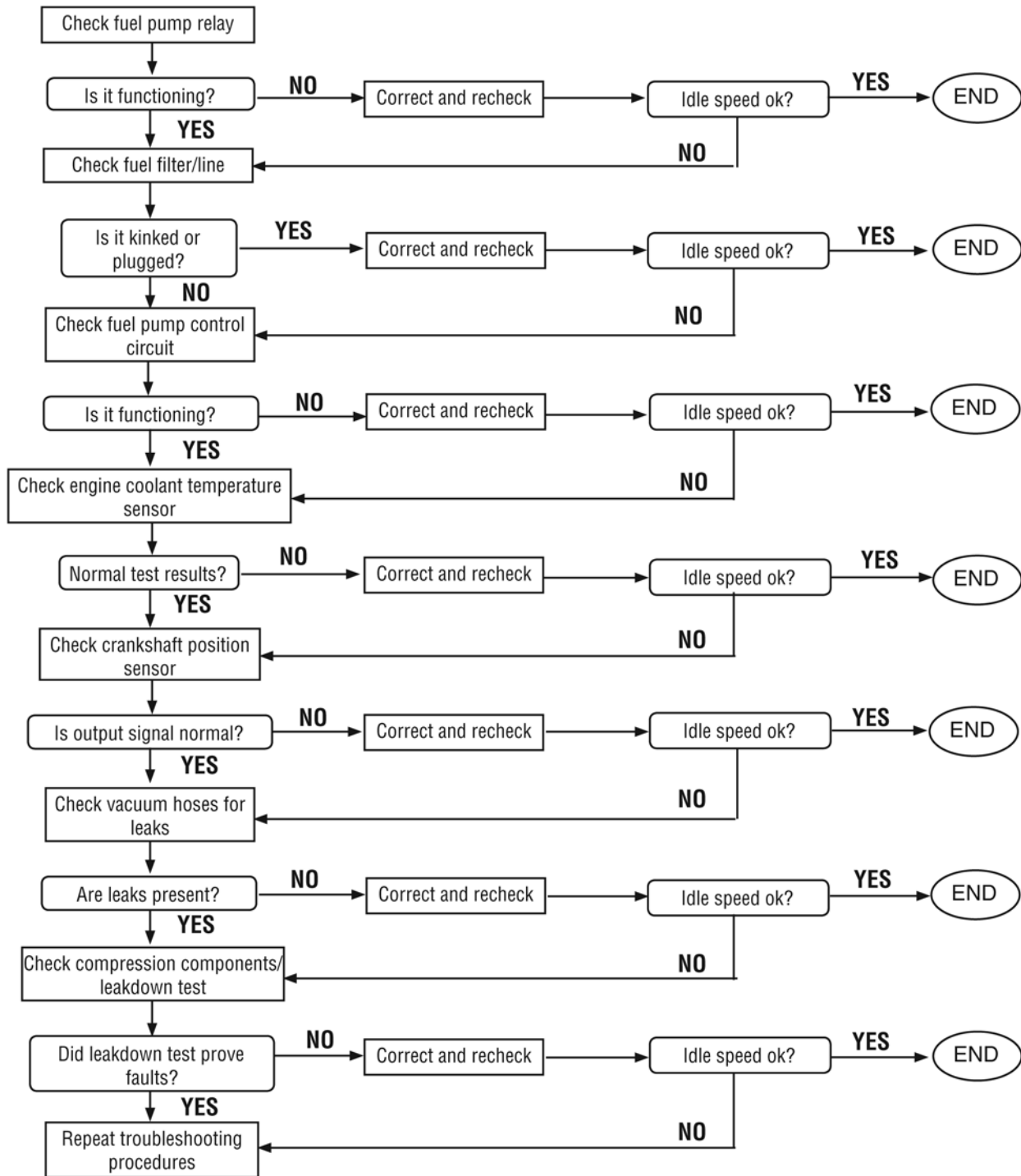

Engine Will Not Turn Over

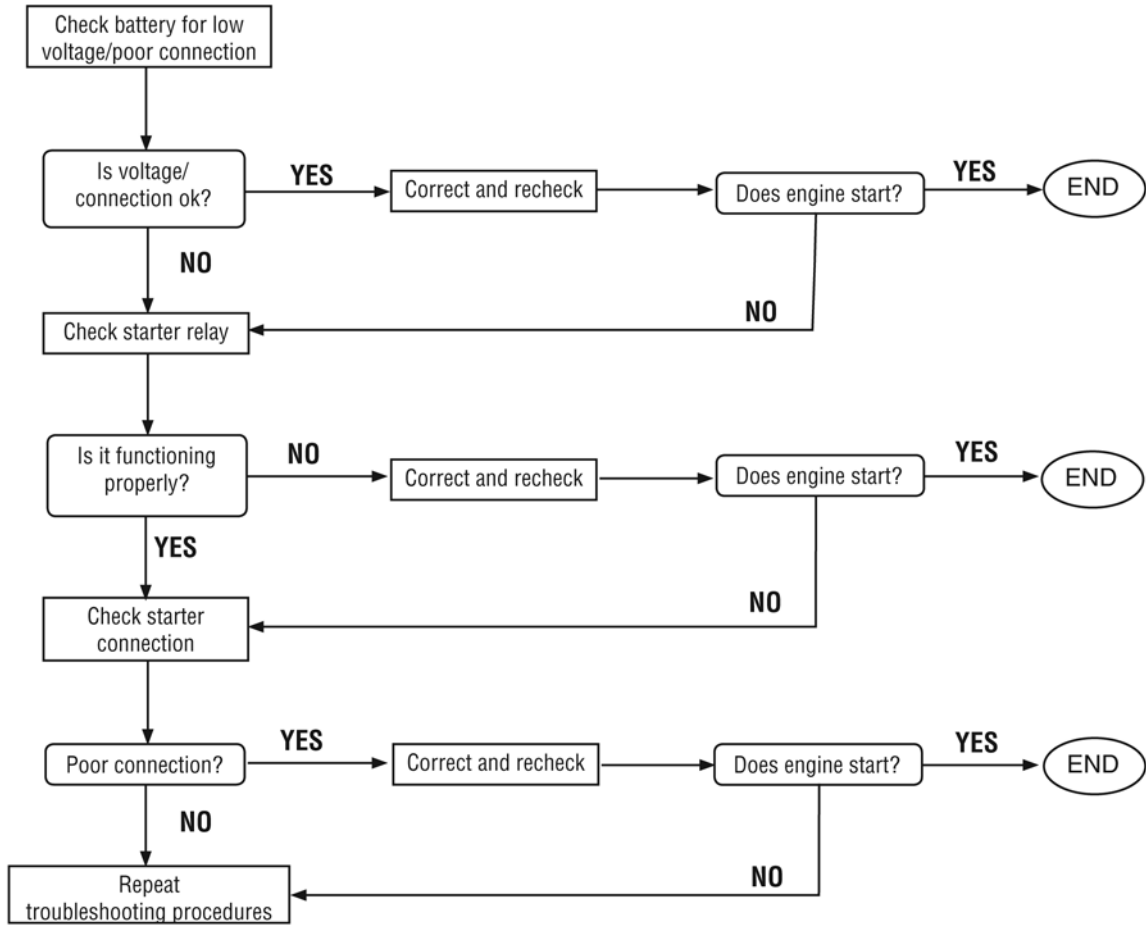

High Idle Speed

10

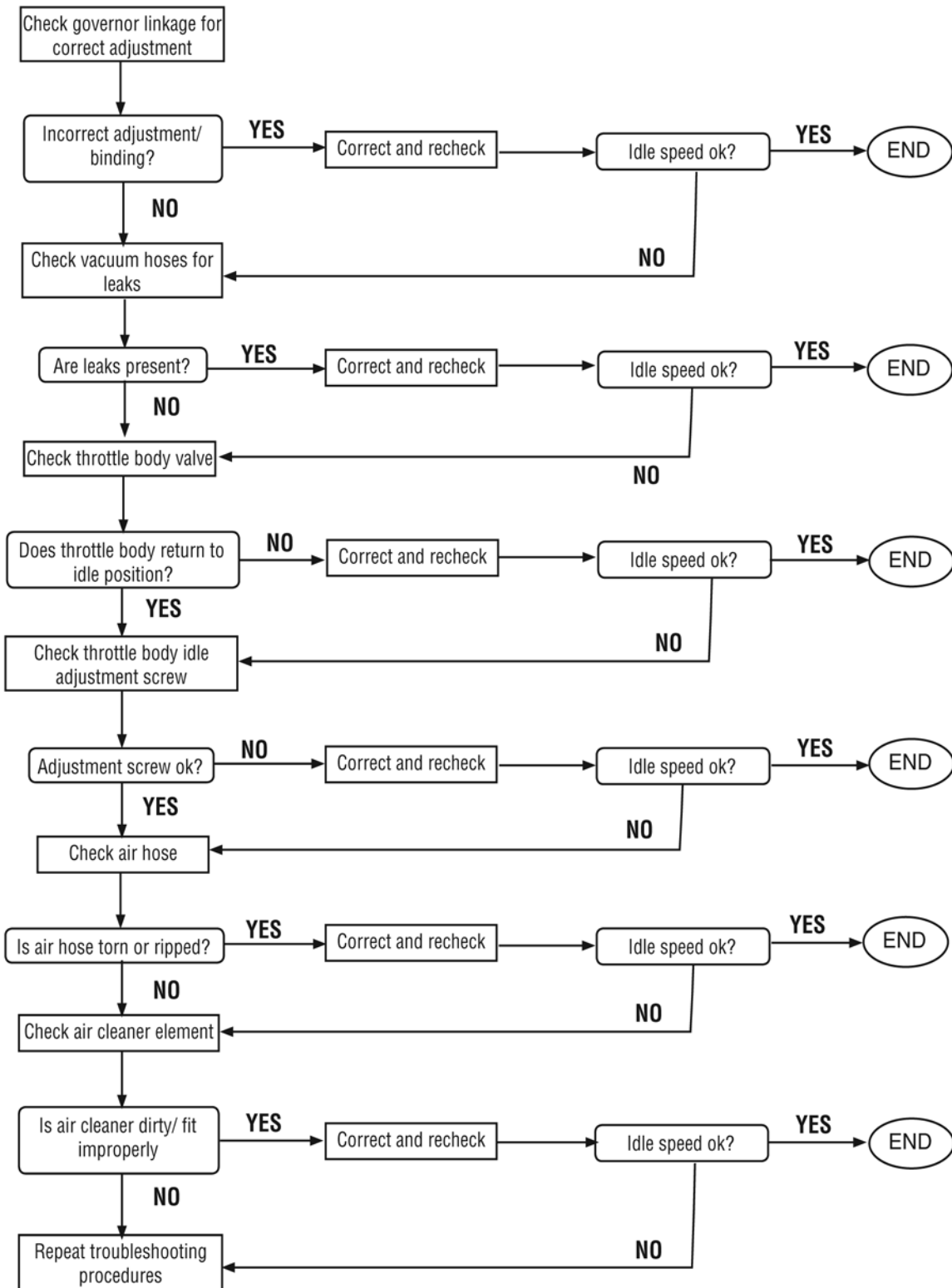

SECTION 11 - ELECTRICAL SYSTEMS

IGNITION SYSTEM COMPONENTS	113
TEST EQUIPMENT	114
TEST TRIGGER	114
IGNITION MODULE	114
TEST IGNITION MODULE ID 19200-87801	115
TEST IGNITION MODULE ID 19200-87804	116
TEST IGNITION COILS	117
14 AMP CHARGING SYSTEM	117
TEST EQUIPMENT	118
TEST ALTERNATOR - AC OUTPUT	118
TEST REGULATOR-RECTIFIER - DC OUTPUT	118
CHARGING INDICATOR CIRCUIT	119
40 AMP CHARGING SYSTEM	120
TEST EQUIPMENT	120
TEST ALTERNATOR-DC OUTPUT	120
DISASSEMBLE ALTERNATOR	120
INSPECT BEARINGS	122
REMOVE BALL BEARING	122
INSTALL BALL BEARING	122
INSPECT ROTOR	122
INSPECT BRUSHES	123
INSPECT REGULATOR	123
INSPECT RECTIFIER	123
ASSEMBLE ALTERNATOR	124
STARTER SYSTEM	126

STARTER CURRENT DRAW TEST	126
TEST STARTER	126
TEST STARTER (NO LOAD)	126
TEST SOLENOID	127
REPLACE SOLENOID	128
INSTALL SOLENOID	128
REMOVE PINION GEAR ASSEMBLY	128
INSTALL PINION GEAR ASSEMBLY	129
DISASSEMBLE STARTER MOTOR	130
INSPECT ARMATURE COMMUTATOR	131
INSPECT BRUSHES	131
ASSEMBLE STARTER	133

Ignition System Components

The ignition system consists of three major components (Figure 1):

1. A permanent trigger and signal rotor integral with the crankshaft pulley.
2. A transistorized ignition module which advances and retards the ignition timing electronically.
3. A battery powered ignition coil for each cylinder.

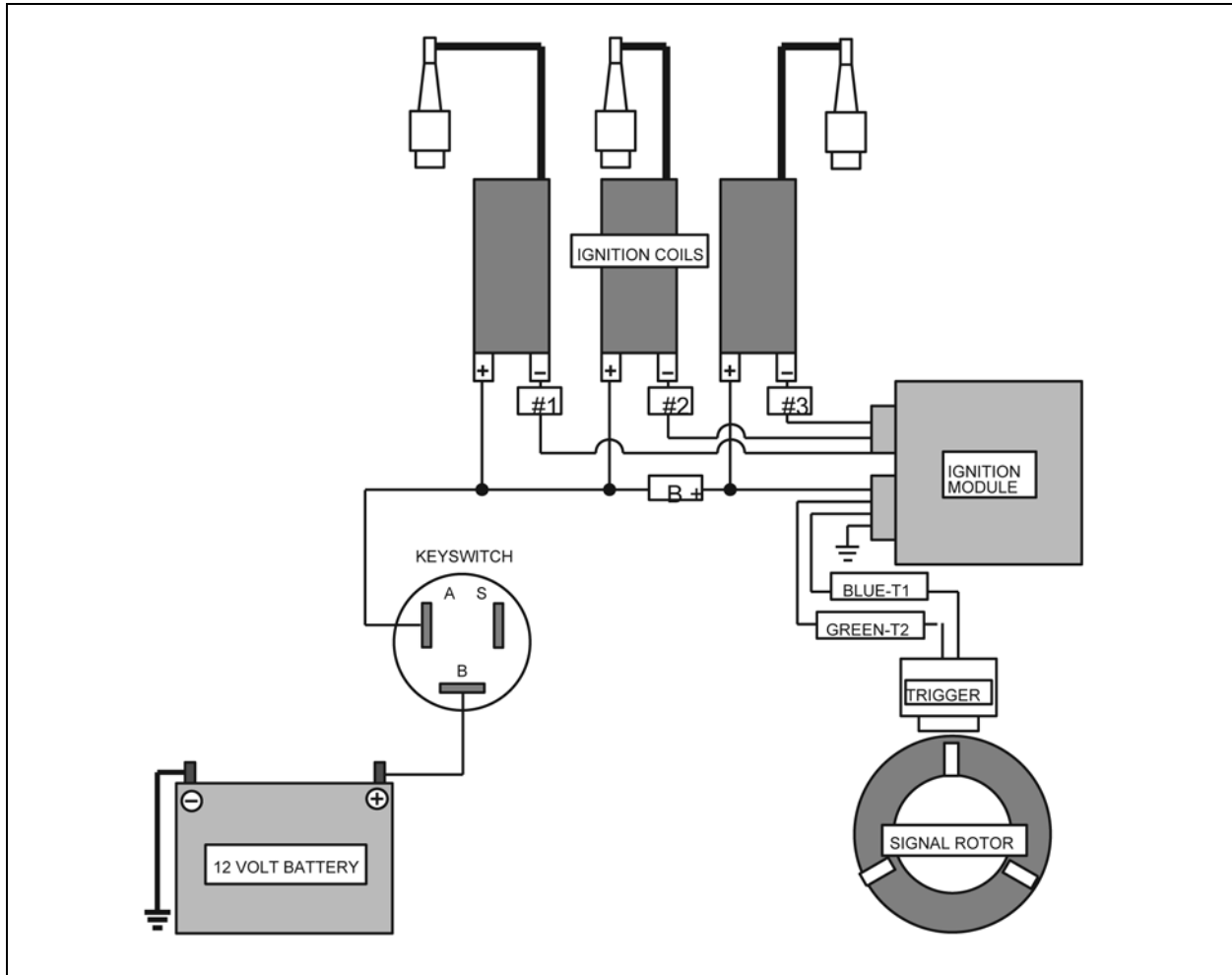

Figure 1

Test Equipment

1. The Digital Multimeter #19390 is required to test the ignition components (Figure 2).

NOTE: All ignition tests are performed with engine NOT running.

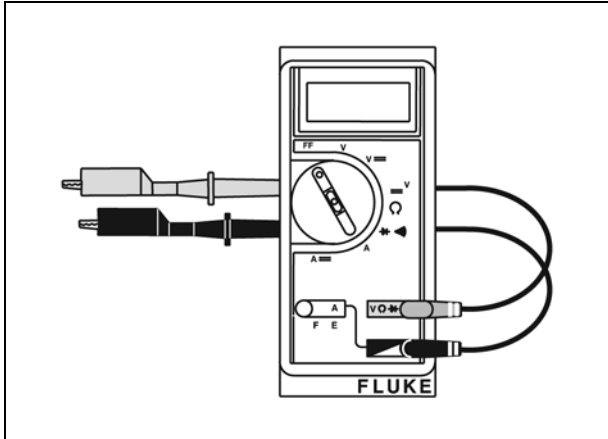

Figure 2

Ignition Module

Two different ignition modules are used. The test specifications are different depending upon the identification number on the ignition module (Figure 4).

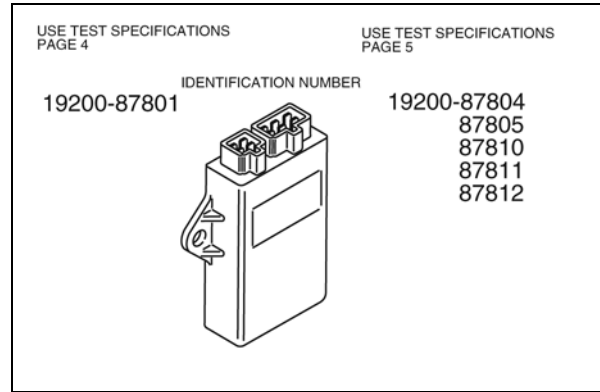

Figure 4

1. Locate the identification number on the ignition module.
2. Refer to correct figure for specifications.

Test Trigger

1. Set the meter to the +)))))) position (Diode Test Position).
2. Attach a meter test lead to each trigger terminal in the connector (Figure 3).

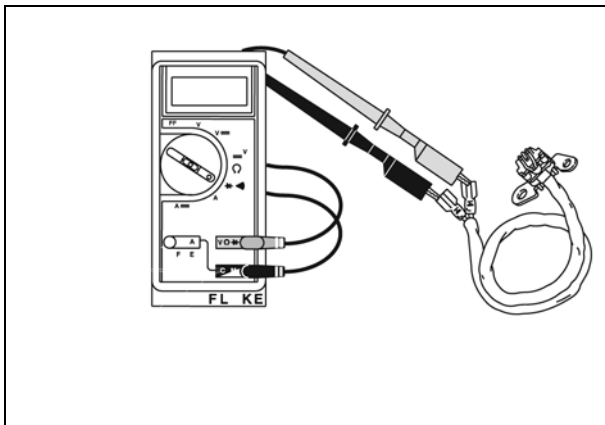

Figure 3

3. Meter should “Beep” once. If meter makes a continuous tone or displays OL, trigger is defective. Replace trigger.
4. Reverse test leads.
5. Meter should “Beep” once. If meter makes a continuous tone or displays OL, trigger is defective. Replace trigger.

Test Ignition Module - Identification NO. 19200-87801

The following test will be made with the meter in the Ω position.

The ignition module test is performed by measuring the resistance (Ω) between the terminals shown in Figure 5. Specifications are shown in the chart below.

Attach red meter test lead to the terminal shown at the top of the column. Attach the black test lead to the terminal shown in the vertical column below and note reading. Then move the black test lead to the next terminal below. Proceed until all the terminals in the vertical column have been tested. Now move the red test lead to the terminal shown at the top of the next vertical column. Proceed until all terminals have been tested.

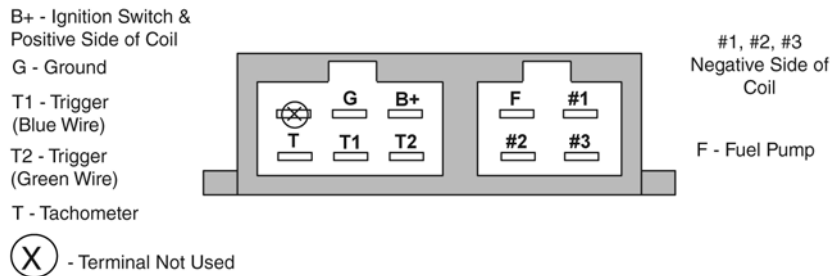

Figure 5

		Red Meter Test Lead									
		B+	G	T1	T2	#1	#2	#3	T	F	I
Black Meter Test Lead	B+	×	1.5 M to OL	1.5 M to OL	1.5 M to OL	1.5 M to OL	1.5 M to OL	1.5 M to OL	1.5 M to OL	1.5 M to OL	1.5 M to OL
	G	1 to 25M	×	5 to 20K	Less than 1W	1.5 M to OL	1.5 M to OL	1.5 M to OL	1 to 5K	1.5 M to OL	0.5 to 2.5K
	T1	1 to 25M	5 to 20K	×	5 to 20K	1.5 M to OL	1.5 M to OL	1.5 M to OL	5 to 25K	1.5 M to OL	5 to 25K
	T2	1 to 25M	Less than 1W	5 to 20K	×	1.5 M to OL	1.5 M to OL	1.5 M to OL	1 to 5K	1.5 M to OL	0.5 to 2.5K
	#1	1.5 M to OL	1 to 25M	1 to 25M	1 to 25M	×	1.5 M to OL	1.5 M to OL	1 to 25M	1.5 M to OL	1 to 25M
	#2	1.5 M to OL	1 to 25M	1 to 25M	1 to 25M	1.5 M to OL	×	1.5 M to OL	1 to 25M	1.5 M to OL	1 to 25M
	#3	1.5 M to OL	1 to 25M	1 to 25M	1 to 25M	1.5 M to OL	1.5 M to OL	×	1 to 25M	1.5 M to OL	1 to 25M
	T	1 to 25M	1 to 5K	5 to 25K	1 to 5K	1.5 M to OL	1.5 M to OL	1.5 M to OL	×	1.5 M to OL	1 to 5K
	F	1.5 M to OL	1 to 25M	1 to 25M	1 to 25M	1.5 M to OL	1.5 M to OL	1.5 M to OL	1.5 M to OL	×	1 to 25M
	I	1 to 25M	0.5 to 2.5K	5 to 25K	0.5 to 2.5K	1.5 M to OL	1.5 M to OL	1.5 M to OL	1 to 5K	1.5 M to OL	×

Values Shown Are Resistance In Ohms (W)

OL = Incomplete Circuit (Infinity)

× = No Test

Test Ignition Module - Identification NO. 19200-87804

The following test will be made with the meter in the Ω position.

The ignition module test is performed by measuring the resistance (Ω) between the terminals shown in Figure 6. Specifications are shown in the chart below.

Attach red meter test lead to the terminal shown at the top of the column. Attach the black test lead to the terminal shown in the vertical column below and note reading. Then move the black test lead to the next terminal below. Proceed until all the terminals in the vertical column have been tested. Now move the red test lead to the terminal shown at the top of the next vertical column. Proceed until all terminals have been tested.

- B+ - Ignition Switch & Positive Side of Coil
- G - Ground
- T1 - Trigger (Blue Wire)
- T2 - Trigger (Green Wire)
- T - Tachometer
- I - Fuel Select Switch

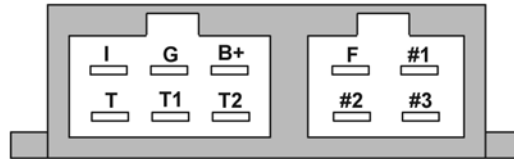

- #1, #2, #3 Negative Side of Coil
- F - Fuel Pump

Figure 6

		Red Meter Test Lead									
		B+	G	T1	T2	#1	#2	#3	T	F	I
Black Meter Test Lead	B+	×	1.5 M to OL	1.5 M to OL	1.5 M to OL	1.5 M to OL	1.5 M to OL	1.5 M to OL	1.5 M to OL	1.5 M to OL	1.5 M to OL
	G	1 to 25M	×	5 to 20K	Less than 1W	1.5 M to OL	1.5 M to OL	1.5 M to OL	1 to 5K	1.5 M to OL	0.5 to 2.5K
	T1	1 to 25M	5 to 20K	×	5 to 20K	1.5 M to OL	1.5 M to OL	1.5 M to OL	5 to 25K	1.5 M to OL	5 to 25K
	T2	1 to 25M	Less than 1W	5 to 20K	×	1.5 M to OL	1.5 M to OL	1.5 M to OL	1 to 5K	1.5 M to OL	0.5 to 2.5K
	#1	1.5 M to OL	1 to 25M	1 to 25M	1 to 25M	×	1.5 M to OL	1.5 M to OL	1 to 25M	1.5 M to OL	1 to 25M
	#2	1.5 M to OL	1 to 25M	1 to 25M	1 to 25M	1.5 M to OL	×	1.5 M to OL	1 to 25M	1.5 M to OL	1 to 25M
	#3	1.5 M to OL	1 to 25M	1 to 25M	1 to 25M	1.5 M to OL	1.5 M to OL	×	1 to 25M	1.5 M to OL	1 to 25M
	T	1 to 25M	1 to 5K	5 to 25K	1 to 5K	1.5 M to OL	1.5 M to OL	1.5 M to OL	×	1.5 M to OL	1 to 5K
	F	1.5 M to OL	1 to 25M	1 to 25M	1 to 25M	1.5 M to OL	1.5 M to OL	1.5 M to OL	1.5 M to OL	×	1 to 25M
	I	1 to 25M	0.5 to 2.5K	5 to 25K	0.5 to 2.5K	1.5 M to OL	1.5 M to OL	1.5 M to OL	1 to 5K	1.5 M to OL	×

Values Shown Are Resistance In Ohms (W)
 OL = Incomplete Circuit (Infinity)
 X = No Test

Test Ignition Coils

The following test will be performed with the meter in the position.

1. Check coil primary resistance between + and - terminals (Figure 7).

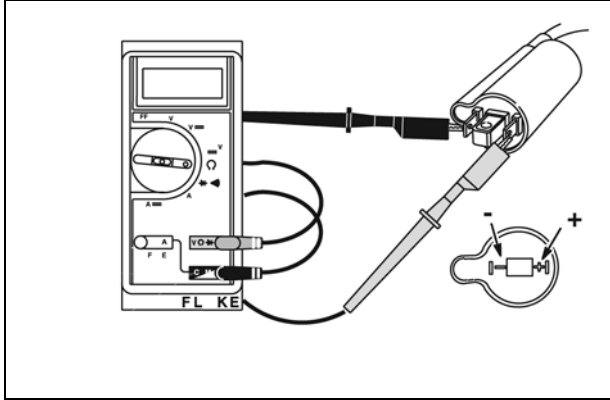

Figure 7

- Specification: $3.4 \Omega - 4.6 \Omega$
 - If ignition coil is not within specification, it must be replaced.
2. Check coil secondary resistance between + terminals and spark plug lead (Figure 8).

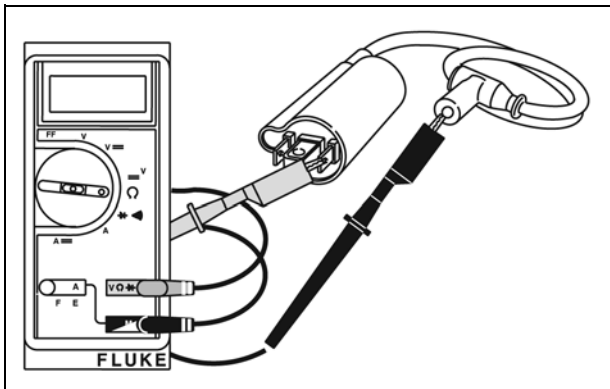

Figure 8

- Specification: $10.4 \Omega - 24.6 \Omega$
- Check spark plug leads for damage (brittleness, crack, etc.).
- If ignition coil is not with specification, or spark plug lead is damaged, it must be replaced.

14 Amp Charging System

The 14 Amp charging system consists of two components:

1. The belt driven permanent magnet alternator produces AC voltage (Figure 9). AC output will vary with engine RPM, from approximately 7 volts AC at 1000 RPM to 32 volts AC at 3000 RPM.
 - A loose V-belt will cause low AC output.
 - Belt deflection limit is $3/8-1/2\text{in}/22\text{lb.}$ ($10.0-12.0 \text{ mm}/10 \text{ kg}$).

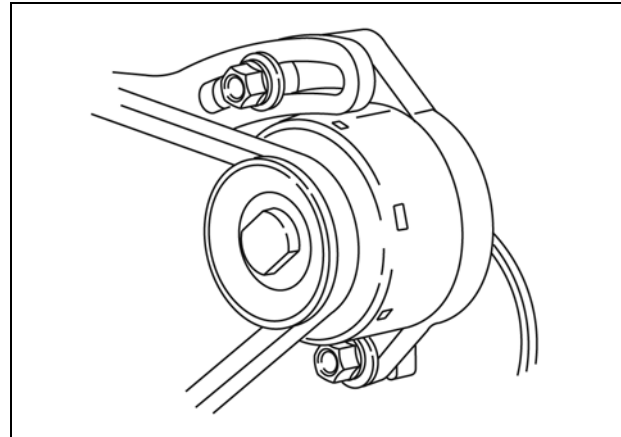

Figure 9

2. The regulator-rectifier converts the AC current to DC and regulates current to the battery (Figure 10). The charging rate will vary with engine RPM. The regulator-rectifier is equipped with a charging indicator light circuit.

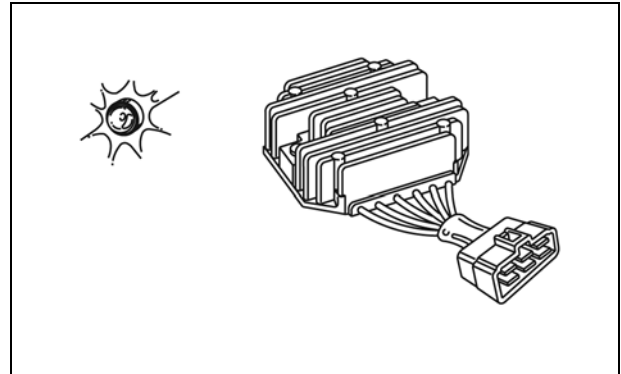

Figure 10

- The regulator-rectifier requires a minimum battery voltage of 6 volts to function. There will be NO charging output if the battery voltage is below 6 volts.

Test Equipment

The Digital Multimeter #19390 and the DC Shunt, #19468 (Figure 11), are required to test the charging system.

NOTE: The digital multimeter will withstand DC input of 10-20 amps for up to 30 seconds. To avoid blowing the fuse in the meter, the DC shunt is required.

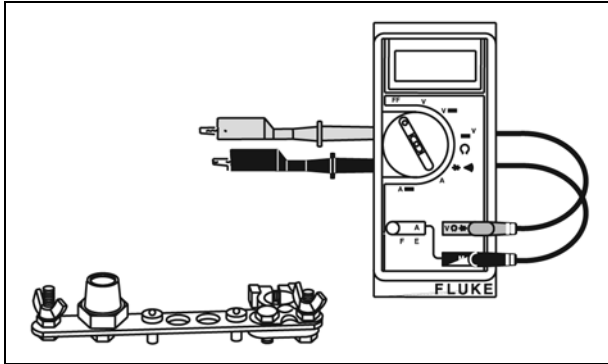

Figure 11

Test Alternator - AC Output

1. The alternator output test will be performed with the meter in the V~ (AC volts) position.
2. Disconnect the alternator wires at the connector.
3. Attach meter test leads to alternator output connectors BEFORE starting the engine (Figure 12).

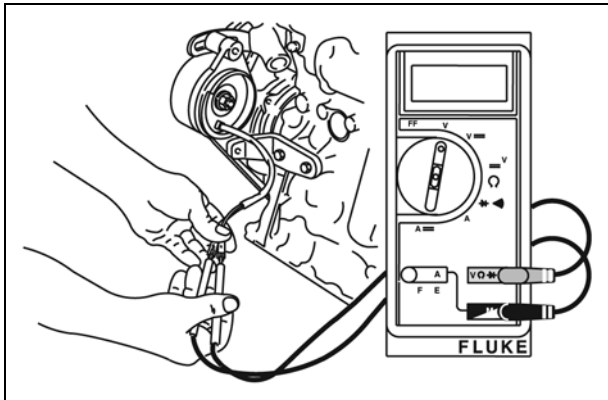

Figure 12

4. With the engine running at 3300 RPM the output should be no less than 28 volts AC.
 - If no output or low output is found, replace the alternator.

- If alternator output is within specification, reconnect alternator wires and test regulator-rectifier.

Test Regulator-Rectifier - DC Output

NOTE: The DC shunt must be installed on the negative (-) terminal of the battery (Figure 13). All connections must be clean and tight for correct amperage readings.

1. Attach meter test leads before starting engine.
2. The regulator-rectifier test will be performed in the **300mV** position.
3. Attach RED meter test lead to the RED post terminal on shunt.
4. Attach BLACK meter test lead to BLACK post terminal on shunt.

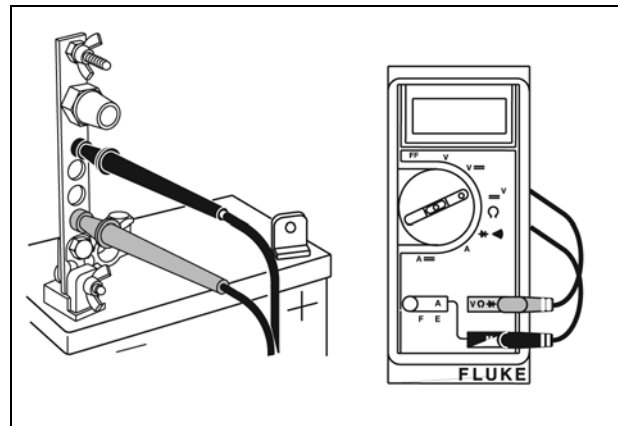

Figure 13

- With engine running at 3300 RPM, the output should be 4-14 Amps.
- If no or low output is found, be sure that the regulator-rectifier is grounded properly and connections are clean and secure. If there is still no or low output, replace the regulator-rectifier.

Charging Indicator Circuit

The green wire from the regulator-rectifier is used to activate the charging indicator light. With the keyswitch in the ON position and the engine not running, the charge indicator light should light (Figure 14). With the engine running, the light should go out, indicating that the battery is being charged.

If the charge indicator light does not light when the keyswitch is in the ON position (engine not running), check the bulb and wiring.

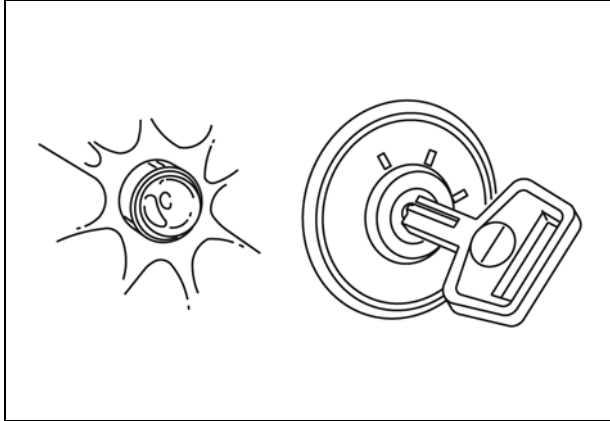

Figure 14

Test Charging Indicator Bulb and Wiring

The following test will be made with the meter in the +))))) position (Diode Test) (Figure 15).

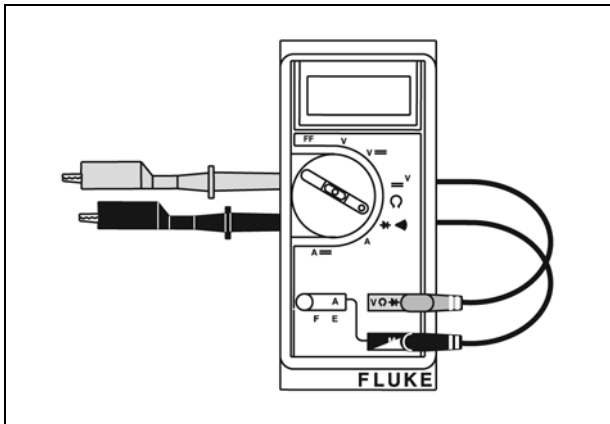

Figure 15

- A continuous tone indicates continuity (complete circuit).
- No tone indicates no continuity (incomplete circuit). An incomplete circuit will be displayed as "OL."

1. Place keyswitch in OFF position.

2. Disconnect output harness at regulator-rectifier.
3. Check continuity between charging indicator wire (green) and ground (Figure 16).

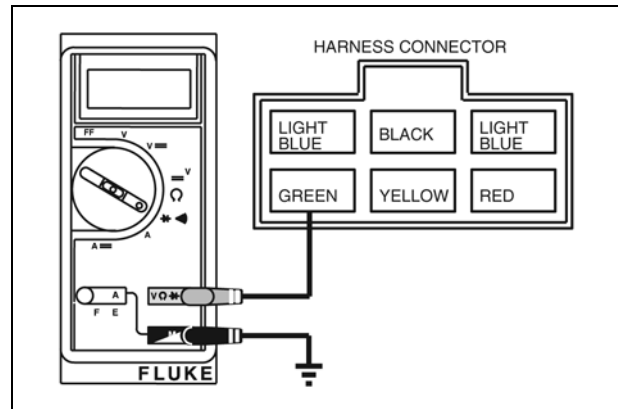

Figure 16

- If meter indicates continuity, bulb and wiring are OK. Replace regulator-rectifier.
 - If meter indicates NO continuity, replace bulb and re-test.
 - If meter indicates NO continuity with new bulb, the problem must be a broken wire (open circuit) in the charging indicator circuit.
4. If the charge indicator light remains on with the engine running, test the regulator-rectifier DC output. If output is within specification and charge indicator light remains on, replace the regulator-rectifier.

40 Amp Charging System

The 40 Amp charging system consists of a belt driven, internally regulated alternator (Figure 17).

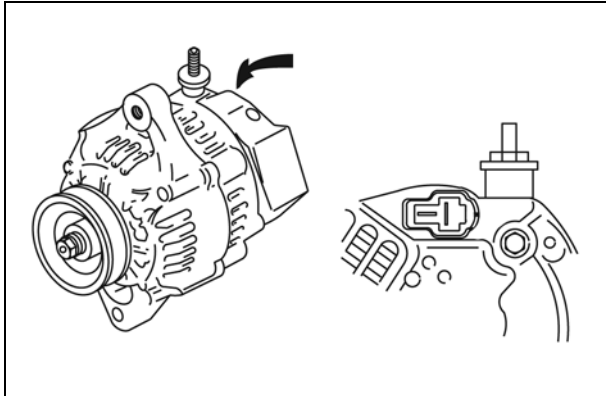

Figure 17

The alternator contains a charge light circuit ("L" terminal). With the keyswitch in the ON position and the engine not running the charge indicator light should light. With the engine running the light should go out, indicating that the battery is being charged.

If the charge indicator light does not light when the keyswitch is in the ON position (engine not running), check the bulb and wiring.

- A loose V-belt will cause low AC output.
- Belt deflection limit is 3/8-1/2in./22lb. (10.0-12.0 mm/10 kg).

Test Equipment

The Digital Multimeter #19390 and the DC Shunt #19468, are required to test the charging system.

NOTE: The digital multimeter will withstand DC input of 10-20 amps for up to 30 seconds. To avoid blowing the fuse in the meter, the DC shunt is required.

Test Alternator - DC Output

NOTE: The DC shunt must be installed on the negative (-) terminal of the battery (Figure 18). All connections must be clean and tight for correct amperage readings.

1. Attach meter test leads before starting engine.

2. The regulator-rectifier test will be performed in the **300mV==** position.
3. Attach RED meter test lead to the RED post terminal on shunt.
4. Attach BLACK meter test lead to BLACK post terminal on shunt.

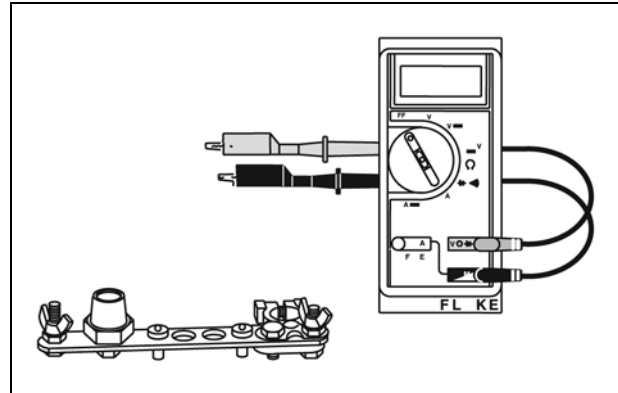

Figure 18

- With engine running at 2000 RPM, the output should be 4-14 Amps.
- If no or low output is found, be sure that the regulator-rectifier is grounded properly and connections are clean and secure. If there is still no or low output, replace the alternator.

Disassemble Alternator

1. Remove pulley nut using tool #SST and 10 mm deep socket (Figure 19).

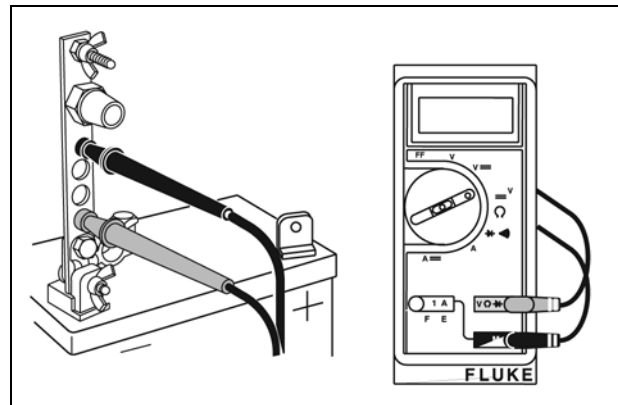

Figure 19

2. Remove pulley and spacer. Replace pulley if damaged or worn.
3. Remove nut and insulator at "B" terminal (A, Figure 20). Remove three screws and brush cover (B).

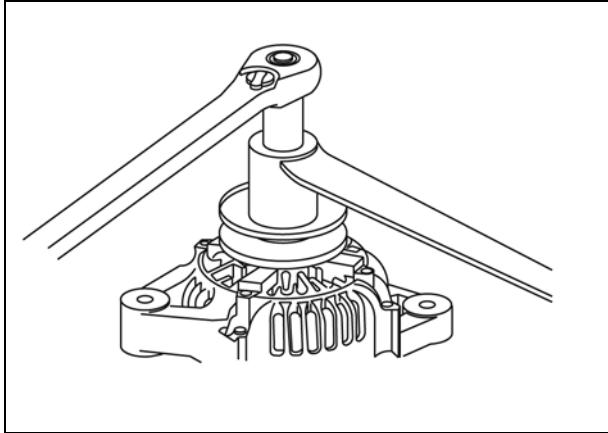

Figure 20

4. Remove two screws and brush retainer assembly (A, Figure 21).

NOTE: Length of brush retainer screws is different. DO NOT mix.

- Screw #1 - 0.45 in. (11.5 mm) (B).
- Screw #2 - 0.35 in. (9.0 mm) (C).

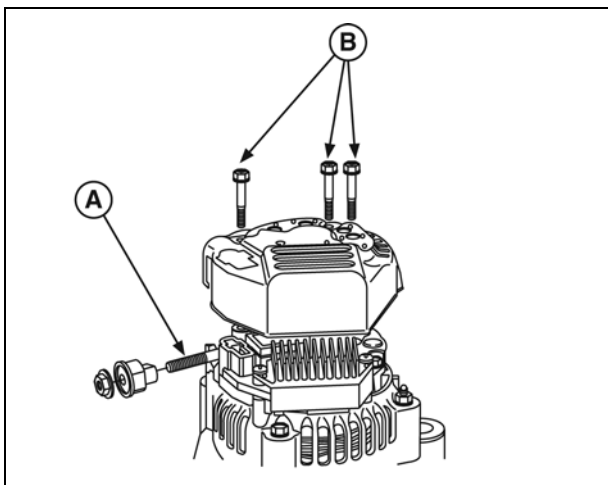

Figure 21

5. Remove three screws and regulator (A, Figure 22).

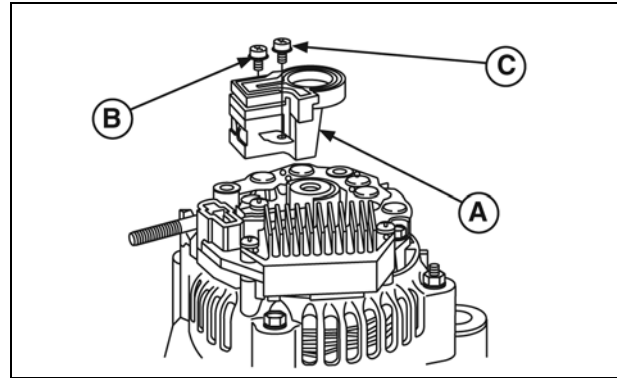

Figure 22

6. Remove stator lead screws from rectifier (A, Figure 23).
7. Carefully straighten stator leads (B) and remove rectifier.

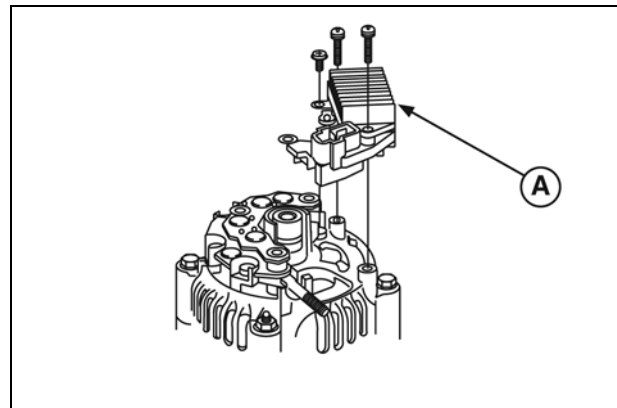

Figure 23

8. Place a reference mark on the drive end and brush end housing so that they may be reassembled in original position.
9. Remove two nuts and two thru bolts (A, Figure 24).
10. Remove brush end housing being careful not to damage stator leads.

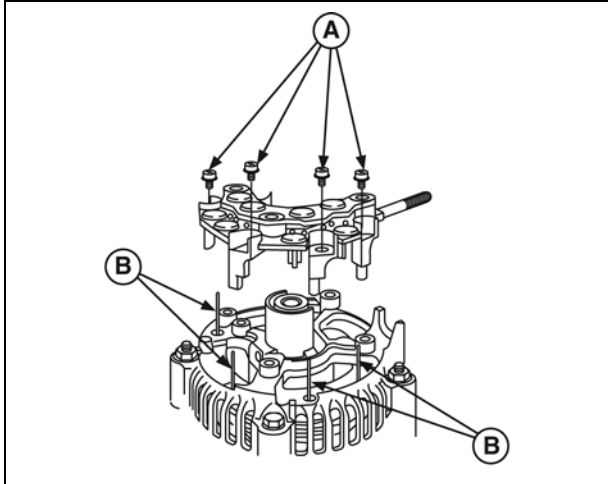

Figure 24

11. Remove rotor from drive end housing (Figure 25).

NOTE: Stator is NOT removable.

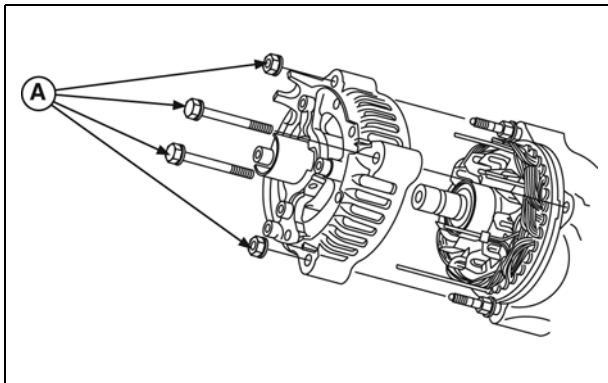

Figure 25

Check Bearings

Ball bearings must rotate freely. If any rough spots are felt, the ball bearing must be replaced.

NOTE: Rotor and ball bearing are an assembly. If bearing is worn, replace rotor assembly.

Remove Ball Bearing

1. Remove four screws and bearing retainer.
2. Support drive housing on blocks.
3. Press out bearing from pulley side of drive end housing using Driver #19416 (Figure 26).

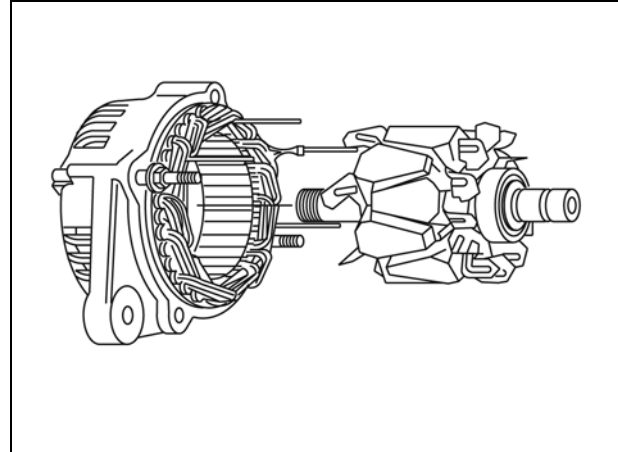

Figure 26

NOTE: DO NOT reuse ball bearings that have been removed from drive end housing. The bearing races are usually damaged during removal.

Install Ball Bearing

1. Lightly lubricate bearing O.D. with engine oil.
2. Press in new bearing using Bearing Drive #19226 (Figure 27).

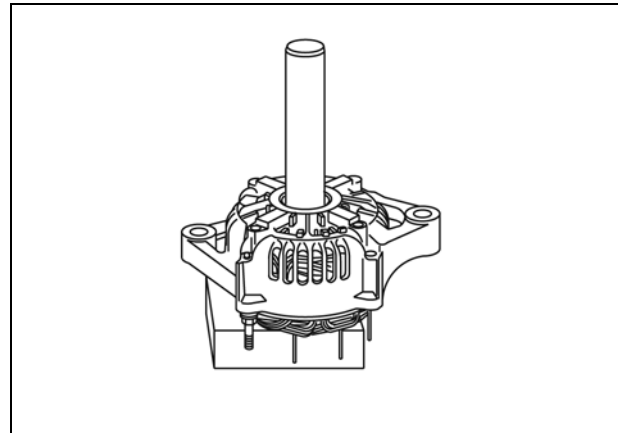

Figure 27

3. Install retainer and four screws.

Check Rotor

1. Set the meter to the +))))) position and check for continuity between slip rings (Figure 28).
 - Meter should make continuous tone (continuity).
 - If meter displays "OL," (no continuity) replace rotor.

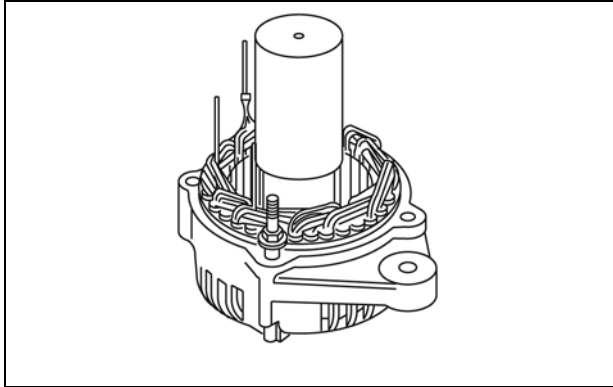

Figure 28

2. Check for continuity between slip ring and rotor shaft.
 - Meter should display “OL,” (no continuity).
3. Measure slip ring diameter (Figure 29).
 - Standard: 0.567 in. (14.4 mm)
 - Reject: 0.551 in. (14.0 mm)

NOTE: Slip rings may be cleaned with fine sandpaper (#300 - 500 grit).

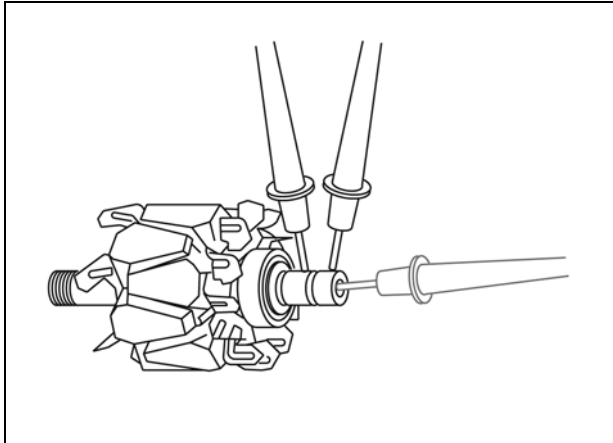

Figure 29

Check Brushes

Measure length of brushes protruding from brush holder (Figure 30).

- Standard: 0.413 in. (10.5 mm)
- Reject: 0.315 in. (8.0 mm)

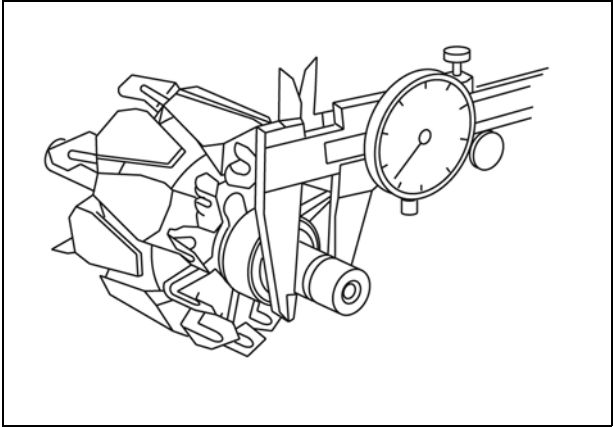

Figure 30

Check Regulator

1. Set the meter to the +))))) position.
2. Attach BLACK meter test lead to terminal (A, Figure 31).
3. Contact Red meter to terminal (B).

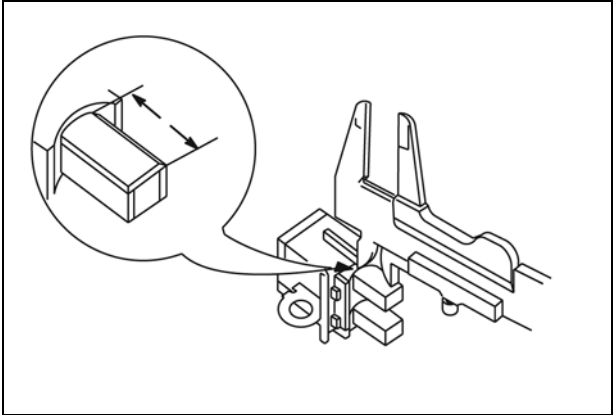

Figure 31

- Meter should “beep” once.
- If meter displays “OL” or makes a continuous tone, regulator is defective. Replace regulator.

Check Rectifier

1. Set meter to the +))))) position.
2. Attach BLACK meter test lead to “B” terminal (Figure 32). Leave attached through Step 4.
3. Contact (A) terminal with red meter test lead.
 - Meter should “beep” once.

- If meter displays “OL” or makes a continuous tone, diode is defective. Replace rectifier.
4. Repeat test at (B,C, and D) terminals.
 - Results must be the same.

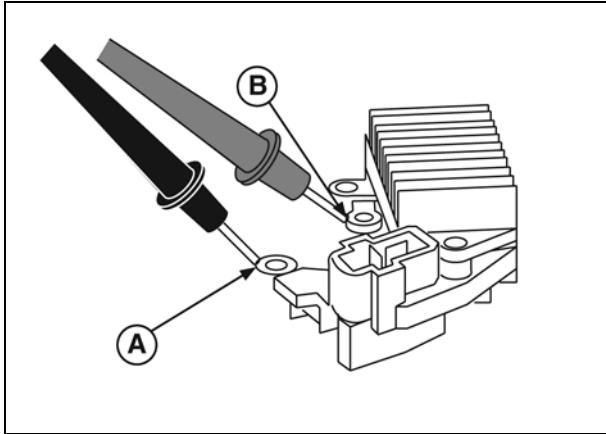

Figure 32

5. Attach RED test lead to one of the three rectifier mounting holes (Figure 33). Leave attached through Step 7.
6. Contact (A) terminal with BLACK meter test lead.
 - Meter should “beep” once.
 - If meter displays “OL” or makes a continuous tone, diode is defective. Replace rectifier.
7. Repeat test at (B, C, and D) terminals.
 - Results must be the same.

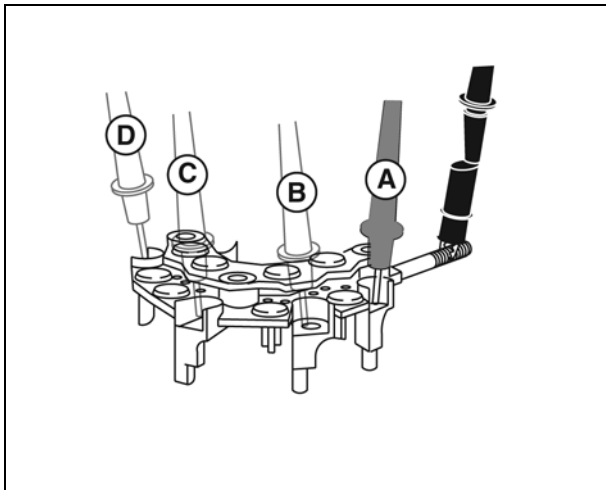

Figure 33

Assemble Alternator

1. Assemble rotor to drive end housing (Figure 34).
2. Assemble spacer, pulley, and nut to rotor shaft. Do not tighten nut at this time.
3. Place pulley side down on work surface.

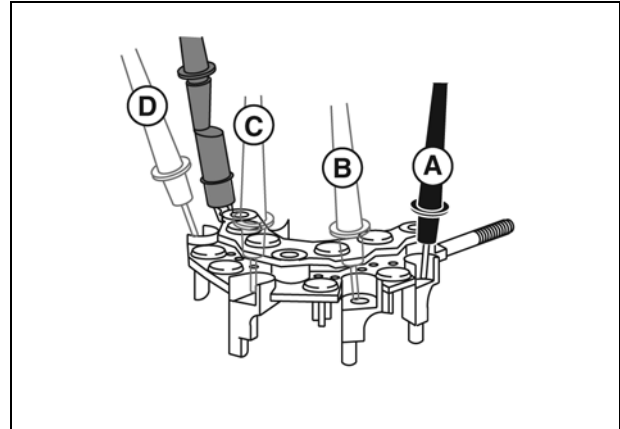

Figure 34

4. Assemble brush end housing to drive end housing with reference marks aligned (Figure 35).

NOTE: Do not damage stator leads.

5. Install thru bolts and nuts and torque to values listed in Section 14 - Engine Specifications.

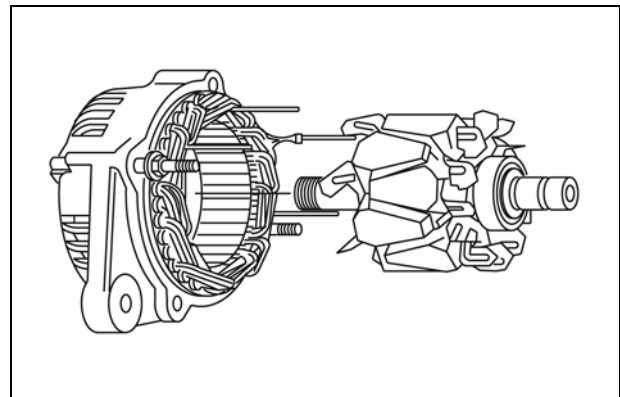

Figure 35

6. Align stator wires with holes in rectifier and assemble rectifier to brush end housing (Figure 36).
7. Carefully form a “U” bend in stator wires. Install screws and tighten securely.

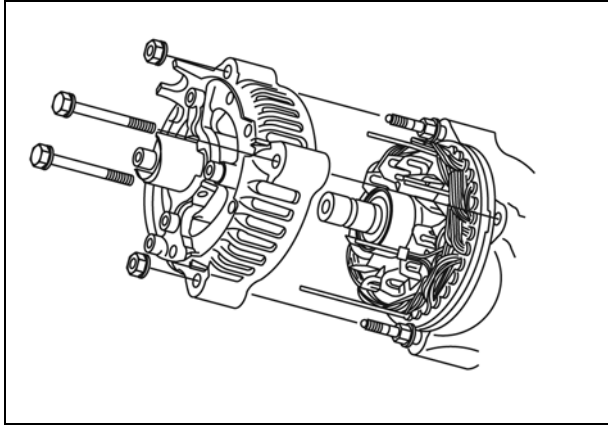

Figure 36

8. Install regulator with screws (**A**, Figure 37).

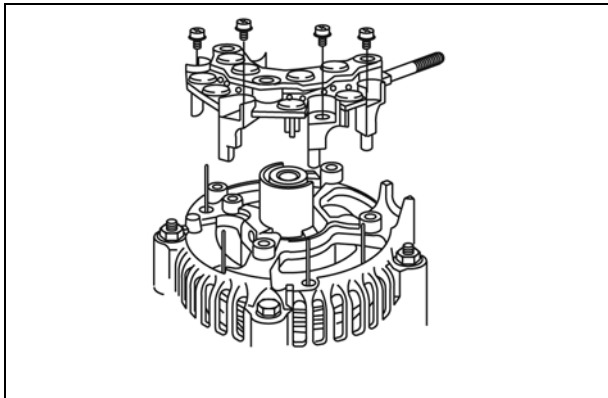

Figure 37

9. Assemble cover (**A**, Figure 38) to brush holder.

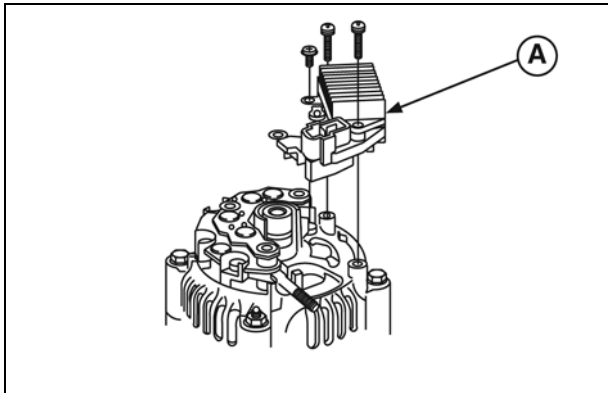

Figure 38

10. Install brush holder.

NOTE: Length of brush retainer screws are different.

- Screw #1 - 0.45 in. (11.5 mm) (**A**, Figure 39).
- Screw #2 - 0.35 in. (9.0 mm) (**B**).

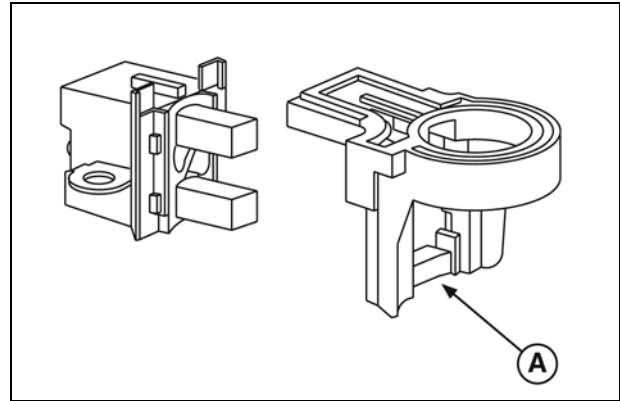

Figure 39

11. Install rear cover and screws (**A**, Figure 40). Torque to values listed in Section 14 - Engine Specifications.
12. Install insulator and nut (**B**) and torque to value listed in Section 14 - Engine Specifications.

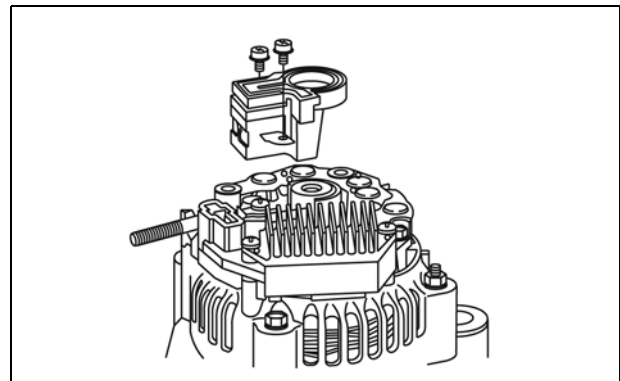

Figure 40

13. Torque drive pulley using the following procedures:
 - Hold nut (**A**, Figure 41) with SST#.
 - With torque wrench, turn 10 mm deep socket **COUNTERCLOCKWISE**. Torque to value listed in Section 14 - Engine Specifications.

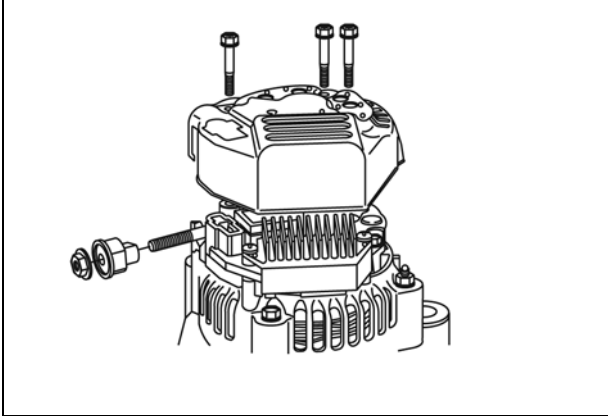

Figure 41

Starter System

The starter system consists of a 12 volt automotive type electric starter with a solenoid (Figure 42). When the solenoid is activated, the drive lever moves the pinion gear into engagement with the flywheel ring gear and allows battery current to flow to the starter motor and crank the engine.

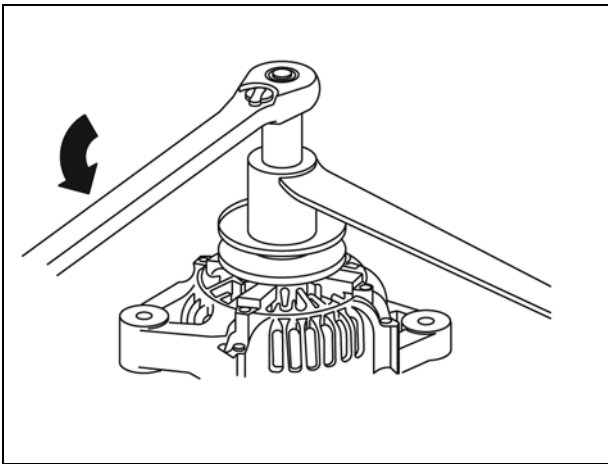

Figure 42

Starter Current Draw Test

NOTE: When making the starter current draw test make sure that all parasitic load is removed from the engine.

Ensure the battery and solenoid connections are clean and tight. Battery voltage must not be below 11.7 volts.

Test Starter

NOTE: To prevent engine from starting, remove spark plug wires from spark plugs. Leave spark plugs installed.

1. Set meter to the **300mV==** position.
2. The DC Shunt must be installed on the negative (-) terminal of the battery (Figure 43).

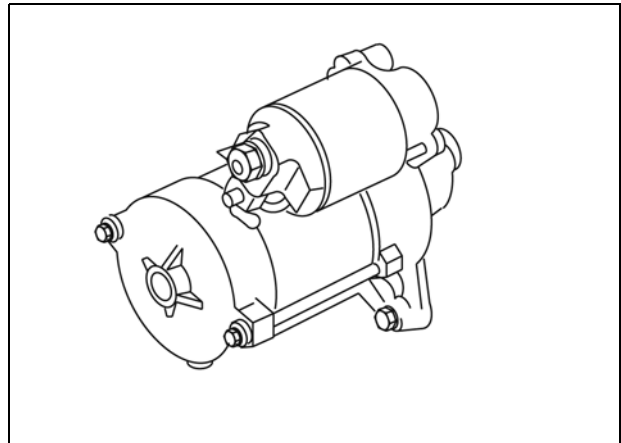

Figure 43

3. Attach RED meter test lead to RED post terminal on shunt.
4. Attach BLACK meter test lead to BLACK post terminal on shunt.
5. Activate starter and allow three seconds for the meter reading to stabilize.
6. Current draw should not exceed 80 amps DC.
7. If amperage exceeds specification, remove starter from engine and perform the No Load starter current draw test.

Test Starter (No Load)

1. Remove starter.

NOTE: To hold starter securely while testing, clamp starter mounting bracket in a vise (Figure 44). DO NOT clamp starter housing in a vise or field windings or magnets may be damaged.

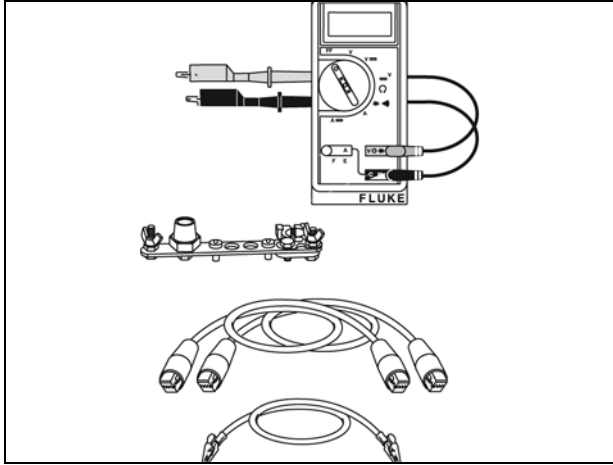

Figure 44

2. Place meter in the 300mV== position.
3. Ensure the DC Shunt is installed on the negative terminal of the battery.
4. Attach RED meter test lead to RED post terminal on shunt.
5. Attach BLACK meter test lead to BLACK post terminal on shunt.
6. Attach negative battery cable to a good ground, such as a driver housing.
7. Attach positive battery cable to battery terminal on solenoid.
8. Attach one end of jumper wire to solenoid tab terminal.
9. Activate starter by contacting positive battery terminal with other end of jumper wire. Allow three seconds for meter reading to stabilize.
10. Current draw should not exceed 50 amps DC.
11. If amperage draw exceeds specification, replace starter.

Test Solenoid

The solenoid test is performed with the starter removed from the engine. The following equipment is recommended to test the solenoid:

- One battery cable with alligator clips (A, Figure 45).
- A jumper wire (B).
- A fully charged 12 volt battery.

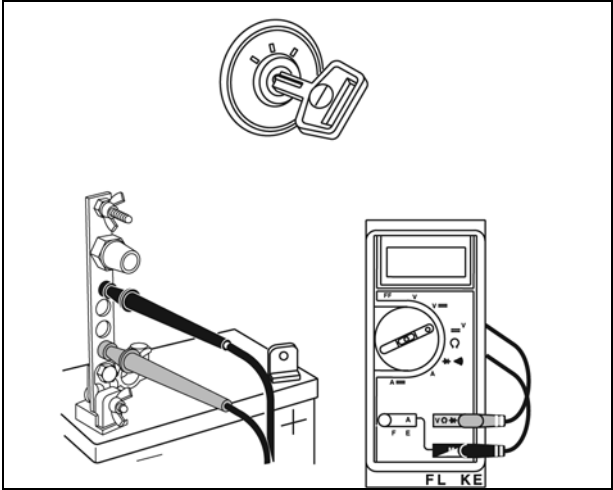

Figure 45

1. Attach one end of battery cable to negative battery terminal and other end of cable to a good ground such as the drive housing (Figure 46).

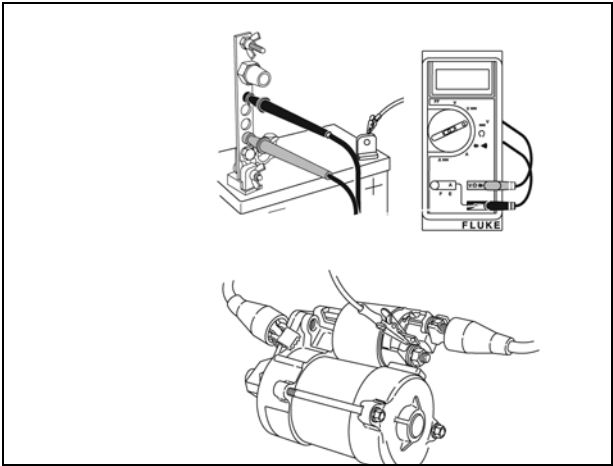

Figure 46

2. Attach jumper wire tab terminal on solenoid.
3. Activate solenoid by contacting positive battery terminal with other end of jumper wire.
 - Pinion must move outward quickly (engage).
4. Remove jumper wire from positive battery cable.
 - Pinion must return quickly (disengage).
5. If the pinion does not move, replace the solenoid. If pinion moves slowly, check for dirty or damaged helix.

Replace Solenoid

1. Remove nut and field coil wire from stud terminal (Figure 47).
2. Remove solenoid mounting nuts and solenoid.
3. Lift solenoid to disengage drive lever from plunger.

NOTE: Hold starter in vertical position with drive housing side down when removing and installing solenoid.

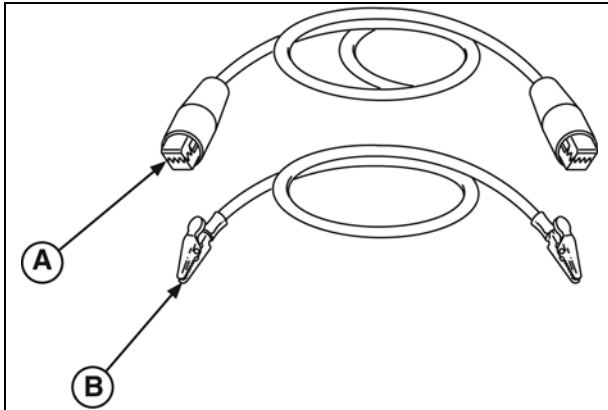

Figure 47

Install Solenoid

NOTE: Small hole in rubber dust cover must face starter.

1. Engage flats on plunger with fork in drive lever and assemble solenoid to starter (Figure 48). Torque nuts to values listed in Section 14 - Engine Specifications.
2. Install field coil wire and nut. Torque to values listed in Section 14 - Specifications.
3. Install starter motor. Torque screws to values listed in Section 14 - Specifications.

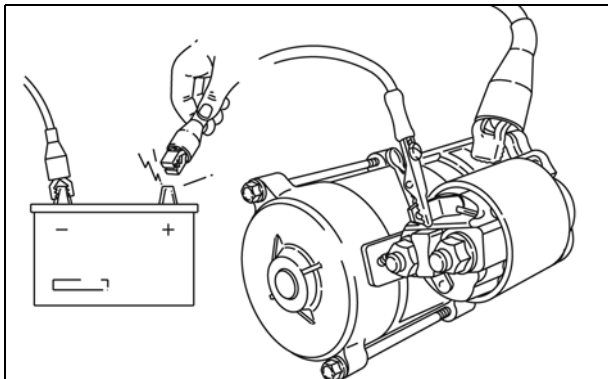

Figure 48

Remove Pinion Gear Assembly

1. Remove solenoid.
2. Remove starter thru bolts (A, Figure 49).

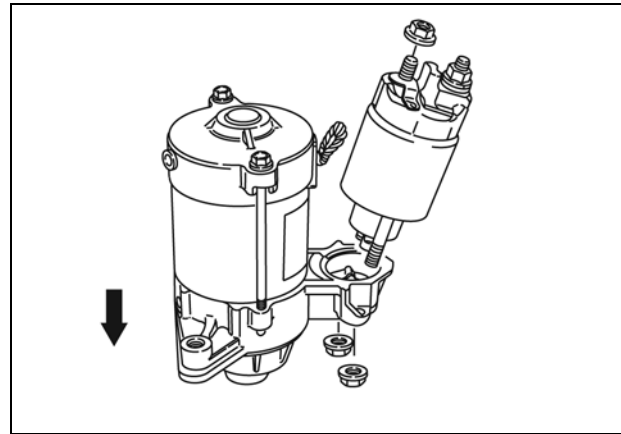

Figure 49

3. Place starter on bench with drive housing up.
4. While holding starter housing, lift off drive end housing with drive lever.

NOTE: DO NOT separate housing from brush end cap or allow armature to move up or it will be necessary to reassemble brushes.

5. Separate split retainer using small screw driver and remove upper retainer (A, Figure 50).
6. Use a 14 mm deep socket and drive lower retainer from snap ring (B).

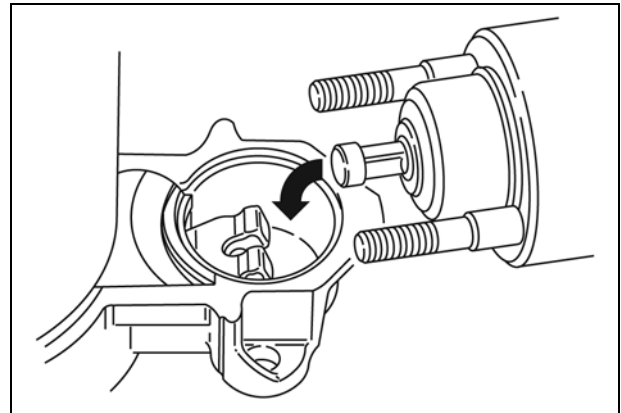

Figure 50

7. Pry off snap rings using small screwdriver (Figure 51).

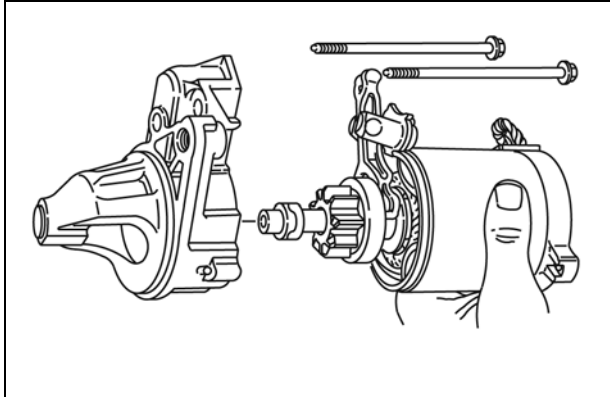

Figure 51

8. Remove and discard lower and upper retainer and snap ring.

NOTE: Always use a new snap ring and split retainer.

9. Remove pinion gear and clutch assembly (A, Figure 52).
10. Clean and inspect helix. If helix is damaged, replace armature.

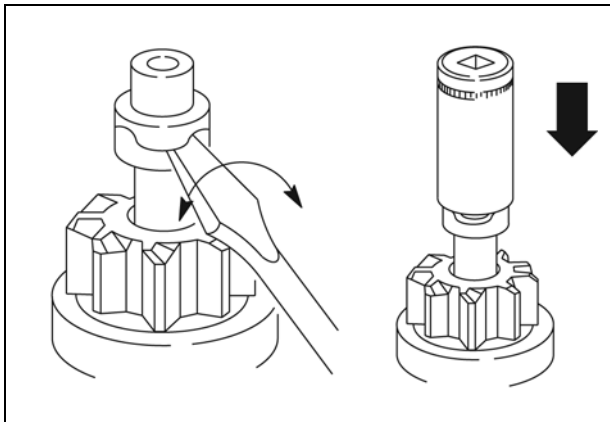

Figure 52

Install Pinion Gear Assembly

1. Lubricate helix with a light coat of grease and assemble pinion gear and clutch.
2. Assemble new lower retainer to shaft (Figure 53).
3. Install new snap ring.

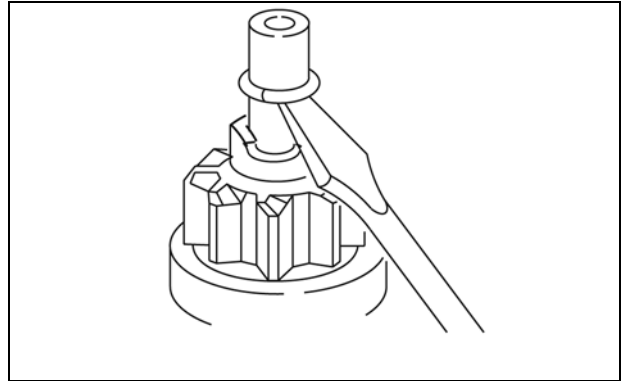

Figure 53

4. Pull up on lower retainer until snap ring snaps into groove in retainer.
5. Install new upper retainer. Push on upper retainer until snap ring snaps into groove into retainer (Figure 54).

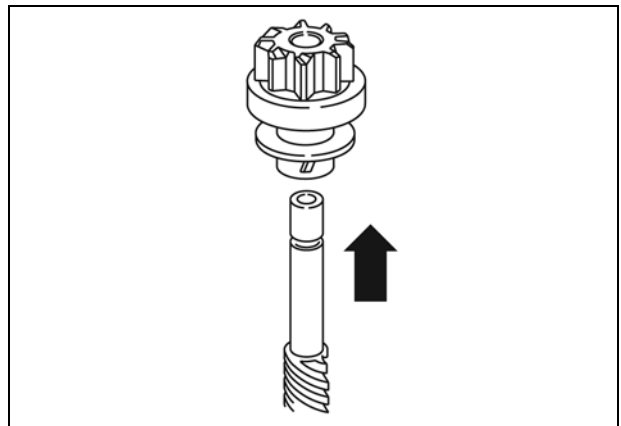

Figure 54

6. Align tab on drive lever with notch in housing (Figure 55).

NOTE: Rubber seal on drive lever support must face end cap.

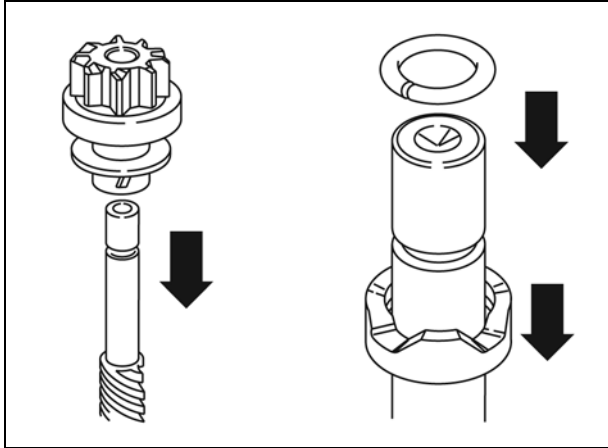

Figure 55

7. Install drive housing (Figure 56).
8. Install thru bolts and torque to value listed in Section 14 - Engine Specifications.
9. Install solenoid.

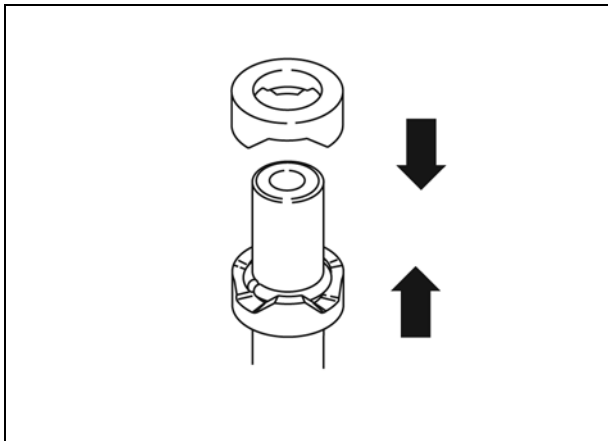

Figure 56

Disassemble Starter Motor

If starter motor is to be disassembled to inspect brushes or commutator, DO NOT remove drive housing.

1. Remove solenoid.
2. Place drive housing in a vise (Figure 57).

NOTE: Take care not to damage drive housing or mounting surface.

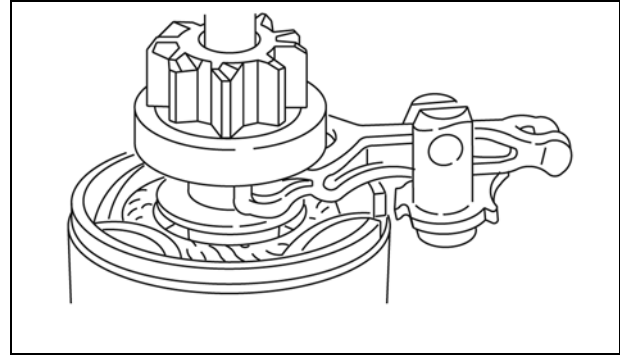

Figure 57

3. Remove thru bolts and lift off end cap.
4. Remove brush retainer plate (**A**, Figure 58).
5. Remove brushes and springs from brush holder (**B**).
6. Remove brush holder. If brush holder or retainer plate are damaged they must be replaced.

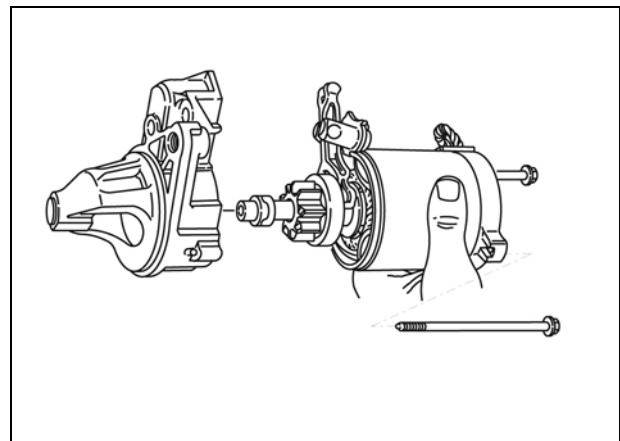

Figure 58

7. Remove starter housing (**A**, Figure 59).
8. Remove armature (**B**) and drive lever (**C**).

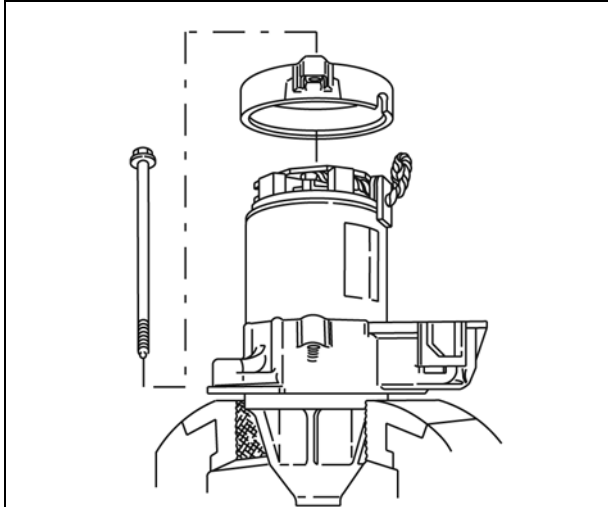

Figure 59

Inspect Armature Commutator

The armature commutator may be cleaned with fine sandpaper (#300-500 grit). DO NOT use emery cloth. Commutator may be machined to no less than 27.0 mm (1.062 in.).

Slots between the commutator bars should be cleaned with a hack saw blade after cleaning and machining (Figure 60).

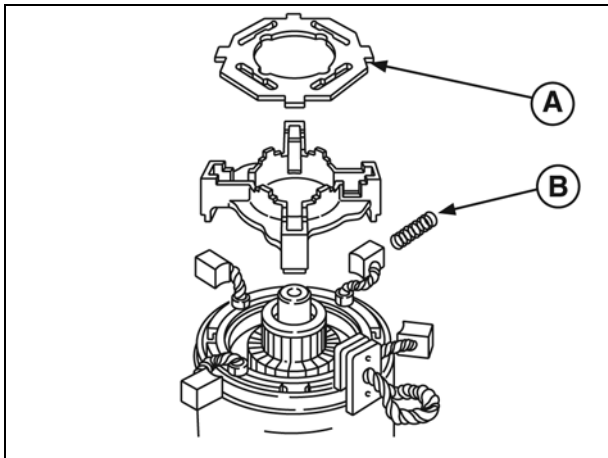

Figure 60

The armature should be checked for shorts with a growler.

Inspect Brushes

Minimum brush dimension is 2.95 in. (7.5 mm) (Figure 61). If brushes are worn less than specification, replace the brushes or stator housing.

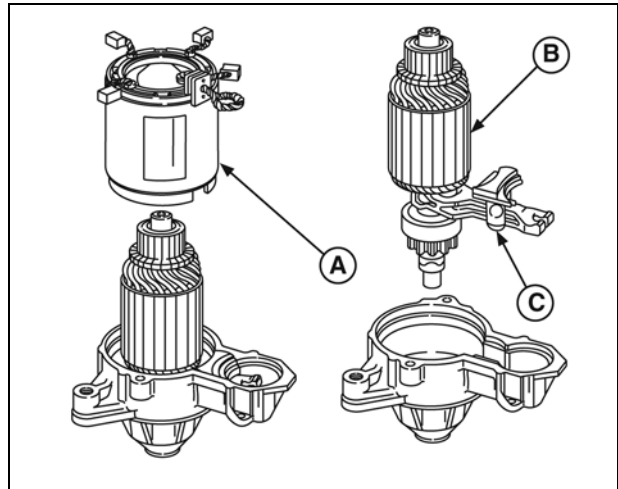

Figure 61

1. Use a digital multimeter to check for continuity between field coil wire and brushes (Figure 62).
2. Set the meter to the +))))) position.
3. Attach either meter test lead to field coil wire.
4. Contact first one, then other brush with other test lead.

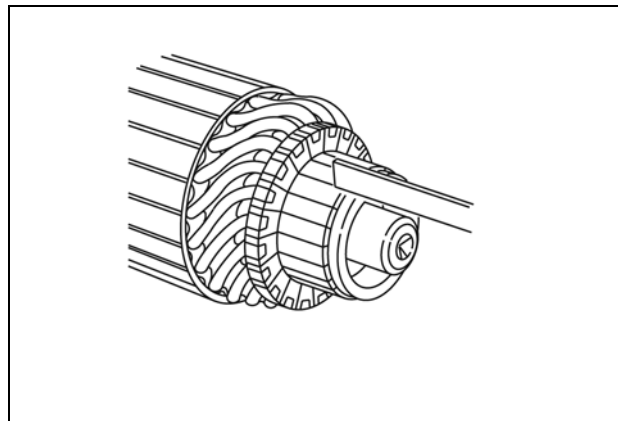

Figure 62

- Meter should make continuous tone (continuity).
 - If meter does not make a tone, (no continuity), replace starter housing.
5. Attach either test lead to starter housing (Figure 63).
 6. Contact first one, then other brush with other test lead.

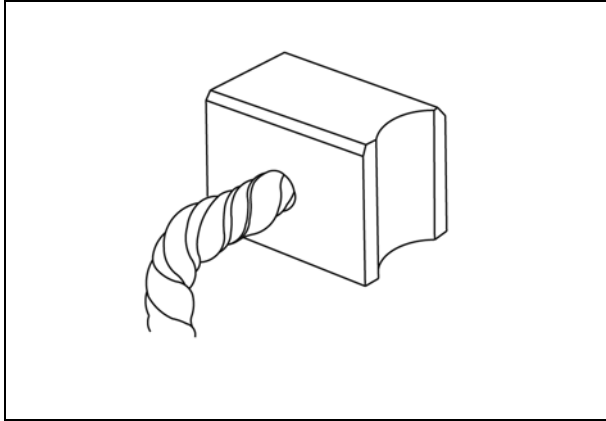

Figure 63

- Meter should make continuous tone (continuity).
- If meter does not make a tone, (no continuity), replace starter housing.

Replace Brushes

1. Cut off brush lead wires at terminals (Figure 64).

NOTE: Terminals are lettered **A**, **B**, **C**, and **D** for easy identification.

NOTE: DO NOT remove field wire from terminal **A**.

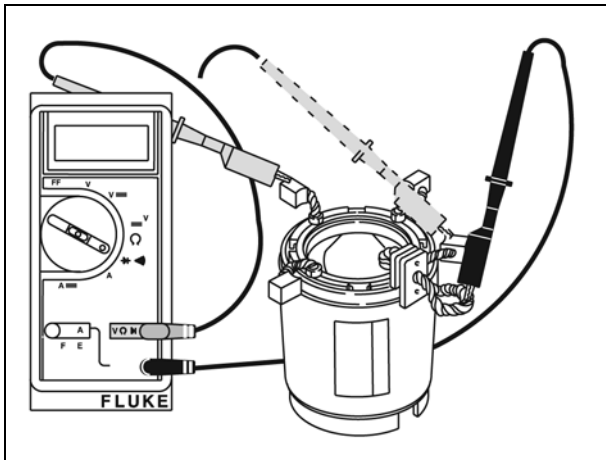

Figure 64

2. Use a fine file and carefully remove remaining lead wire from terminals.

NOTE: Terminals **B** and **D** must be no less than the following specifications (Figure 65):

- L: 0.063 - 0.070 in. (1.6 - 1.8 mm)
- W: 0.255 - 0.295 in. (6.5 - 7.5 mm)

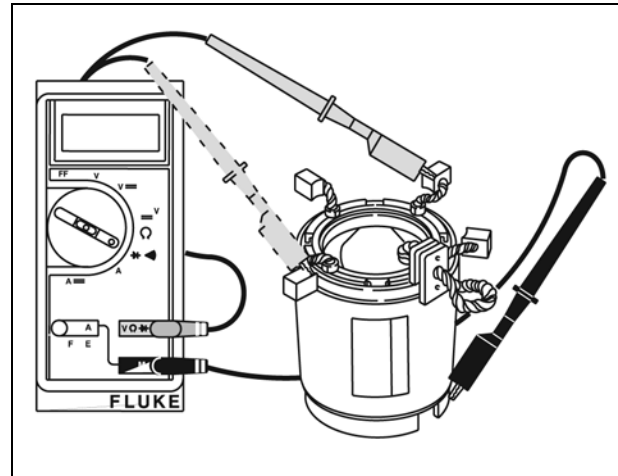

Figure 65

3. Crimp replacement brushes over terminals so that wires face in counterclockwise direction (Figure 66).

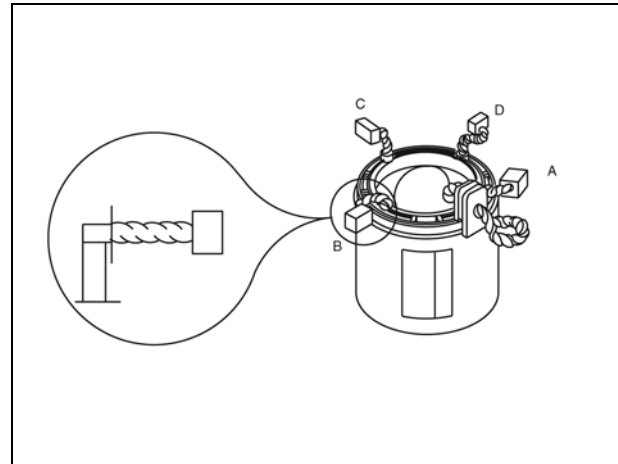

Figure 66

4. Solder brush lead wires to terminals (Figure 67).

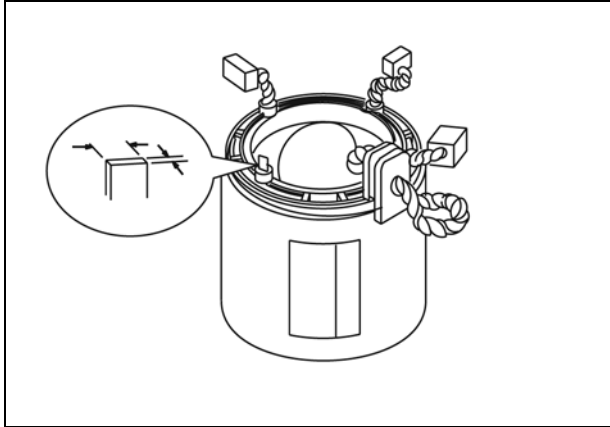

Figure 67

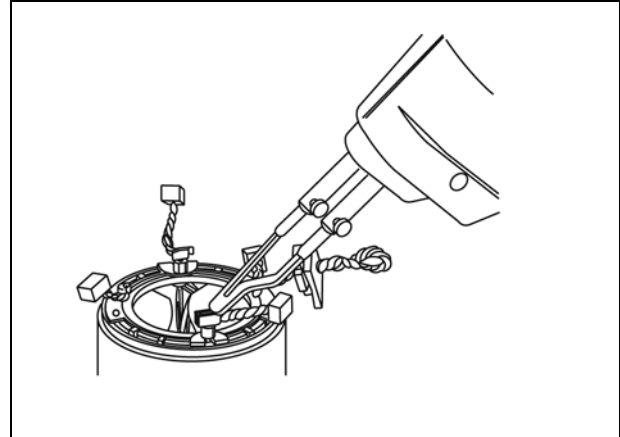

Figure 69

Assemble Starter

1. Assemble drive lever to pinion and install armature and drive lever into drive housing (Figure 68).

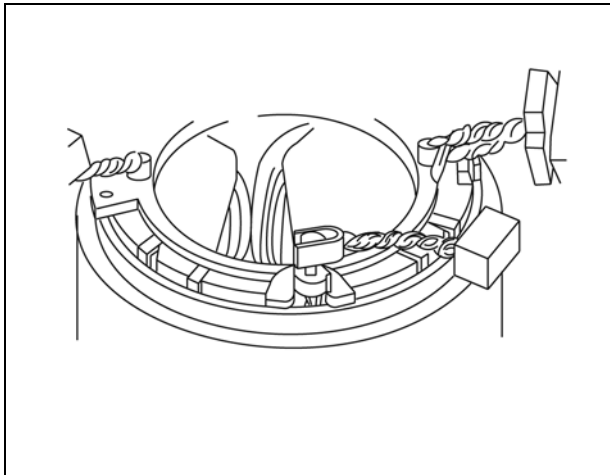

Figure 68

2. Assemble starter housing to drive housing, aligning notch in housing with tab on drive lever support (Figure 69).

3. Install brush holder, inserting tabs on brush holder into slots in starter housing (Figure 70).

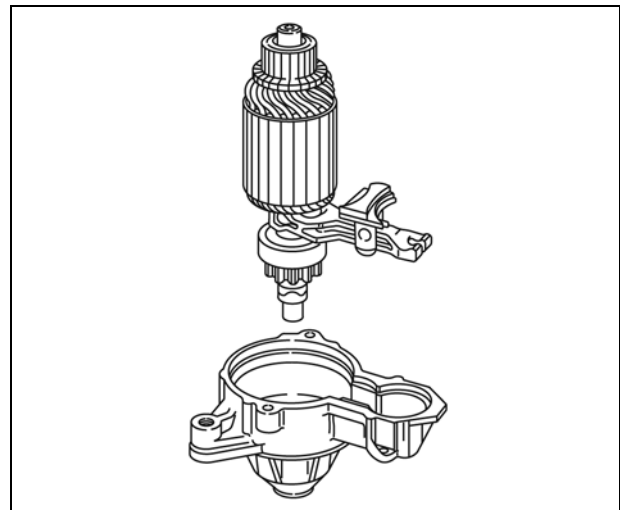

Figure 70

4. Insert brush springs.
5. install brushes (Figure 71).
 - Use a small screwdriver to compress spring.

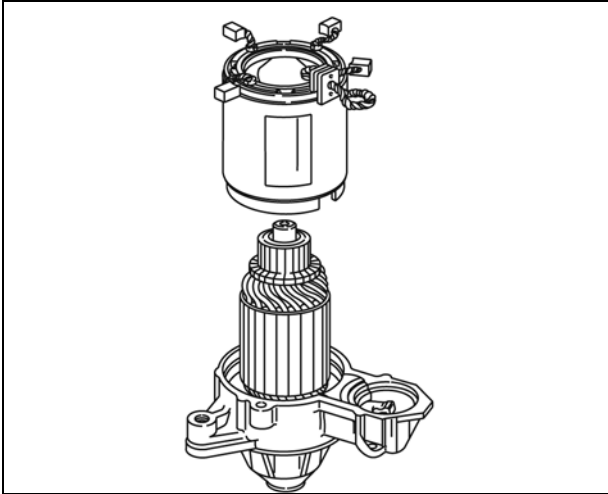

Figure 71

6. Install brush retainer plate.
7. Assemble rubber seal to starter housing (Figure 72).
 - Be sure notch in rubber seal is inserted over tab on housing.

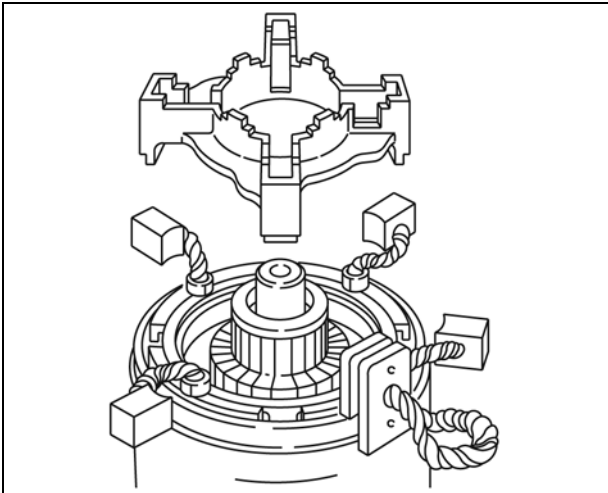

Figure 72

8. Install end cap (Figure 73) and torque thru bolts to values listed in Section 14 - Engine Specifications.
9. Install solenoid.
10. Install starter motor and torque screws to values listed in Section 14 - Engine Specifications.

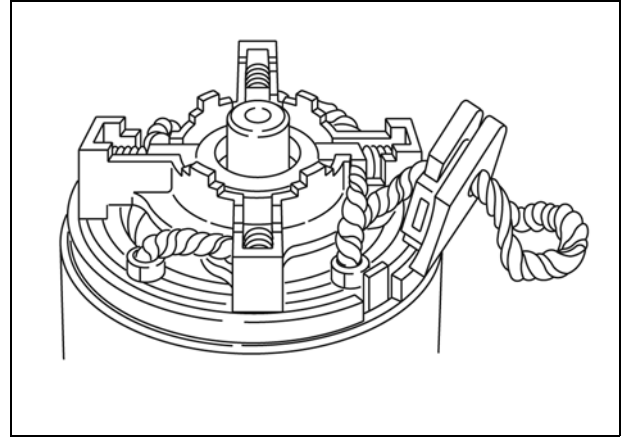
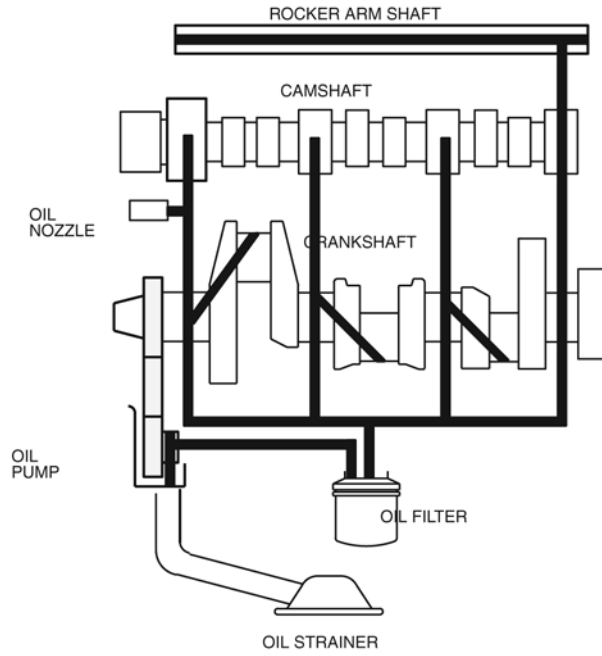

Figure 73

SECTION 12 - LUBRICATION SYSTEM

CHANGE OIL-	137
CHANGE OIL FILTER-	137
CHECK OIL PRESSURE	138
DISASSEMBLE GEAR CASE	138
REMOVE OIL PUMP	138
REMOVE GEAR CASE-	140
ASSEMBLE TIMING GEAR CASE AND GEARS-	140
ADJUST GOVERNOR	143

LUBRICATION SYSTEM



Description

Briggs & Stratton Daihatsu gasoline and diesel engines use a full pressure lubrication system with an oil filter. The gear driven oil pump draws oil from a screened oil pickup in the oil pan and pumps the oil through the oil filter.

The filtered oil flows through oil galleries in the cylinder block and is distributed to the main bearings, connecting rod bearings, camshaft bearings, and rocker arm shaft.

A pressure relief valve limits the maximum oil pressure in the system.

Change Oil

Change oil and filter after first 50 hours of operation. Thereafter, change oil and filter every 200 hours of operation. Change oil and filter more often if engine is operated in dusty or dirty conditions or if engine is operated under heavy loads or high ambient air temperatures.

1. Remove oil drain plug (A, Figure 1) and drain oil while engine is still warm.

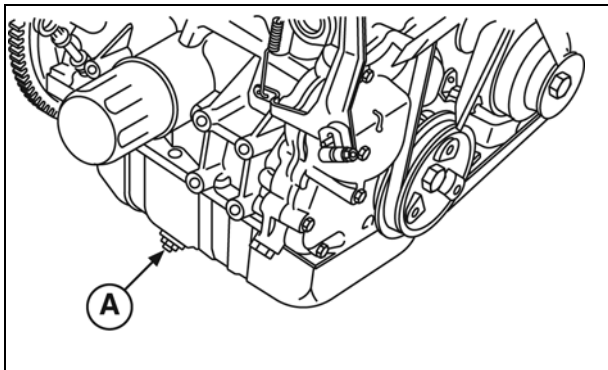

Figure 1

2. Check oil drain plug gasket and replace if necessary. Install and torque drain plug to value listed in Section 14 - Engine Specifications.
3. Remove oil fill cap (A, Figure 2) and refill with oil of recommended grade and viscosity.

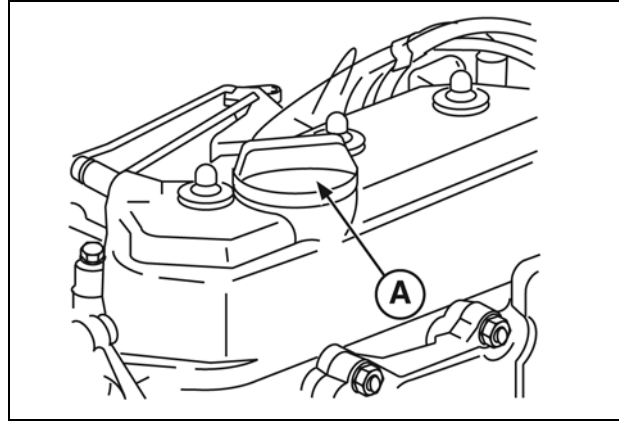

Figure 2

- Oil capacity: 3.3 liters (3.5 quarts)
- Fill to FULL mark on dipstick.

Change Oil Filter

1. Change oil filter every 200 hours of operation.
2. Before installing new filter, lightly oil filter gasket with fresh engine oil.

NOTE: Hand tighten 1/2 turn (Figure 3) after gasket contacts mounting surface.

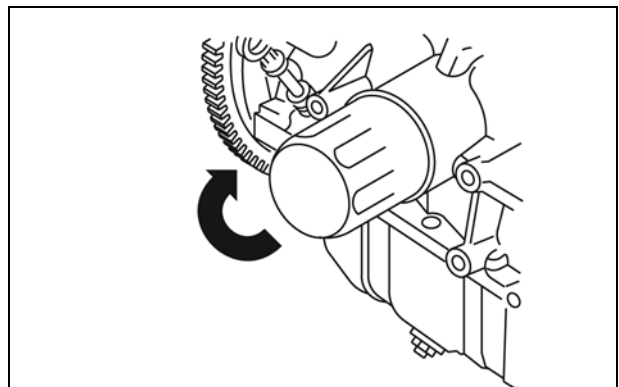

Figure 3

Check Oil Pressure

1. Oil level should be between the LOW and FULL mark on the dipstick (Figure 4). If oil level is low, check for leaks and add to FULL mark.

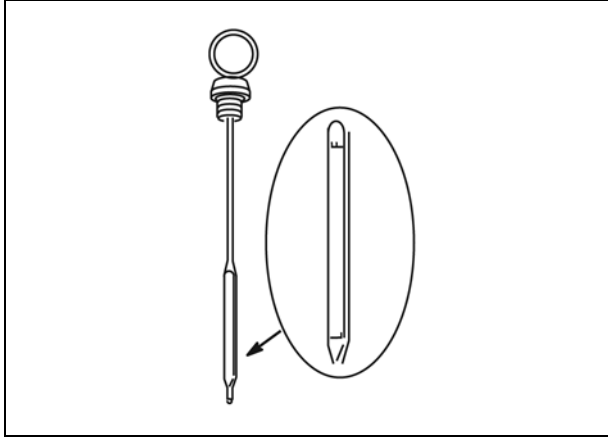

Figure 4

2. Remove oil pressure switch (**A**, Figure 5).
3. Install oil pressure gauge (**B**).

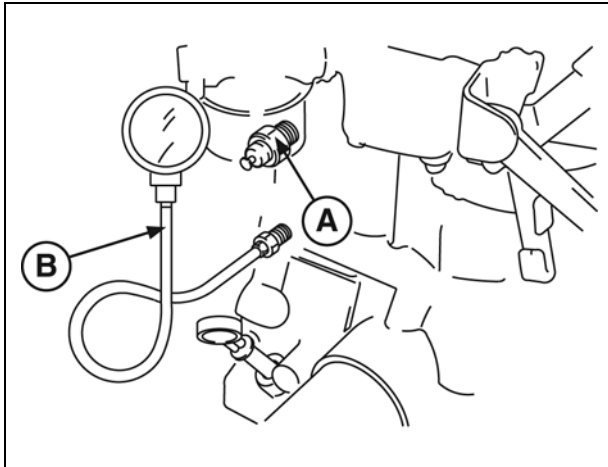

Figure 5

4. Start the engine and allow it to reach normal operating temperature.
5. Check oil pressure at 3000 RPM.
 - Oil Pressure: 2.0 ~ 4.8 Bar (28 ~ 70 psi)
 - See chart below for troubleshooting:

Low Oil Pressure
Engine RPM Too Low
Wrong Viscosity or Diluted Oil
Low Oil Level
Broken Pressure Relief Spring
Missing Pressure Relief Plunger
Worn Bearings
Damaged or Defective Oil Pump
High Oil Pressure
Wrong Viscosity Oil
Plugged Oil Galleries

Disassemble Gear Case

Remove Oil Pump

1. Remove spark plugs, V belt and fan (if equipped), and drain oil from engine.

NOTE: Make sure the Number 1 cylinder is at Top Dead Center (TDC), compression stroke. See Section 2.

NOTE: Before removing governor spring, note hole position of governor spring in governor lever.

2. Remove governor link spring (**A**, Figure 6) and governor link from carburetor.
3. Remove governor spring from governor lever (**B**).
4. Loosen nut (**C**) and remove governor lever from governor shaft.

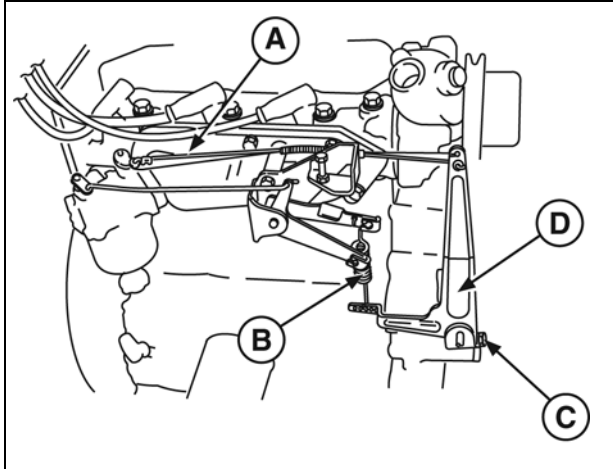

Figure 6

- 5. Remove oil pan screws and nuts.
- 6. Remove oil pan and discard gasket.
- 7. Remove oil pick-up tube (A, Figure 7) and strainer. Discard gasket.

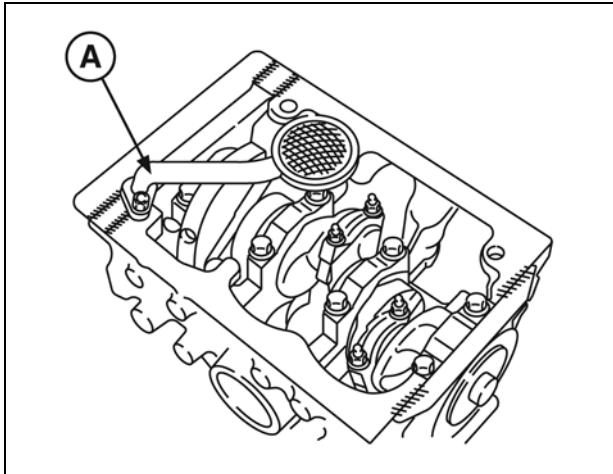

Figure 7

- 8. Remove bell housing adapter screw (if equipped) and install Flywheel Holder #19418 (A, Figure 8).

NOTE: Leave tool installed.

- 9. Remove crankshaft pulley using Crankshaft Puller #19420 (B).

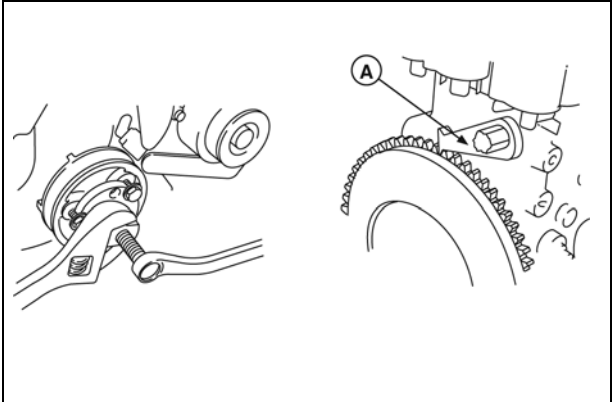

Figure 8

- 10. Remove trigger (Figure 9) and wire. Remove timing gear cover and discard timing gear gasket.

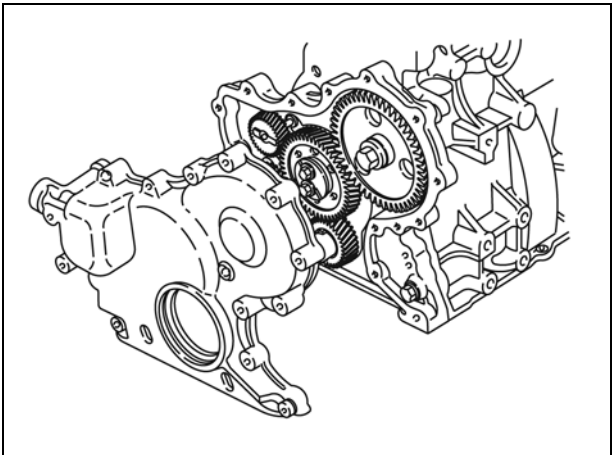

Figure 9

- 11. Remove camshaft timing gear (A, Figure 10).
- 12. Remove idler gear (B).

NOTE: It is not necessary to remove idler gear shaft.

- 13. Check that oil pump turns freely by rotating gear (C) by hand.
- 14. Remove oil pump drive gear.
- 15. Disengage flywheel holder.

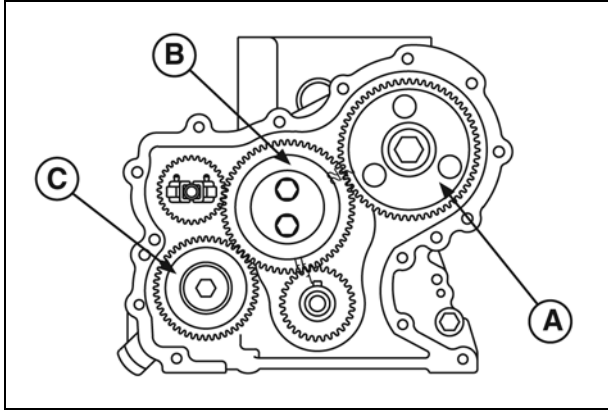

Figure 10

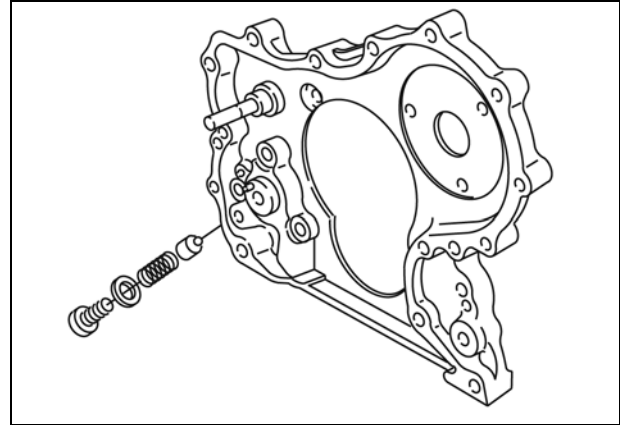

Figure 12

Remove Gear Case

1. Remove three screws (**A**, Figure 11) and camshaft retainer.
2. Remove remaining five screws (**B**).

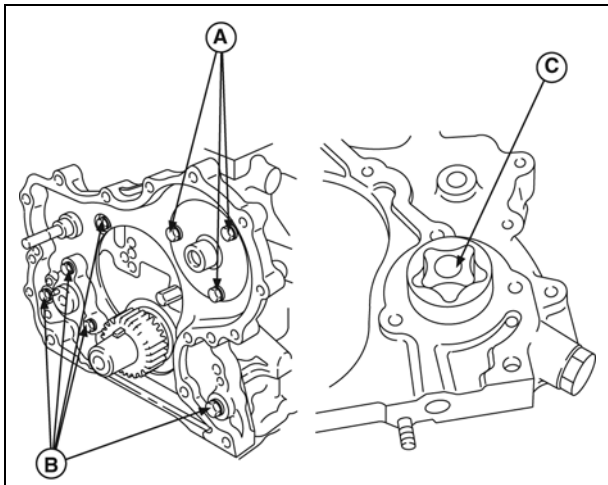

Figure 11

3. Remove timing gear case and discard gasket.
4. Inspect rotors for wear or damage.

NOTE: If pump rotors are worn or damaged, replace the gear case.

5. Remove and check pressure relief valve assembly (Figure 12).
 - Make sure plunger has no nicks or burrs.
 - Check pressure relief valve spring length.
 - Spring free length: 35.5 +/- 1.0 mm (1.4 +/- .040 in.)

Assemble Timing Gear Case and Gears

1. Clean and lubricate oil pump rotor (**A**, Figure 13) with engine oil and install in cylinder block.

NOTE: ID mark (**B**) on rotor must face cylinder block.

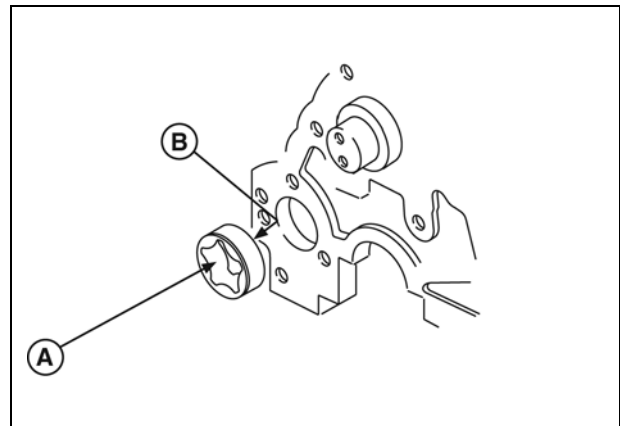

Figure 13

2. Install timing gear case with new gasket. Install camshaft retainer (Figure 14).

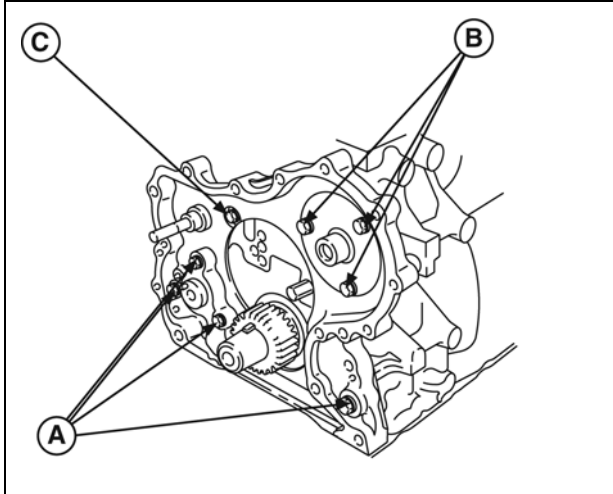

Figure 14

NOTE: It may be necessary to rotate oil pump drive to engage oil pump rotors.

NOTE: Position camshaft retainer so that the center hole does not interfere with the camshaft.

3. Note position, length, and number of screws (Figure 15).
 - M6 x 1.1 in. (M6 x 28 mm): 4 (A)
 - M6 x 0.7 in. (M6 x 18 mm): 3 (B)
 - M6 x 0.6 in. (M6 x 16 mm): 1 (C)
4. Torque screws to values listed in Section 14 - Engine Specifications.
5. Make sure crankshaft key is at the 12 o'clock position (A, Figure 15).

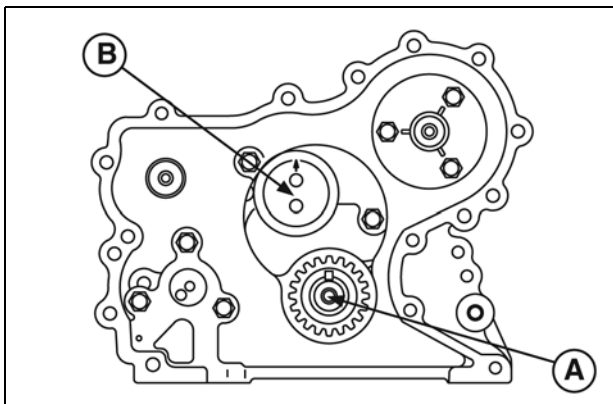

Figure 15

6. Assemble idler gear shaft with arrow up (B, Figure 16).

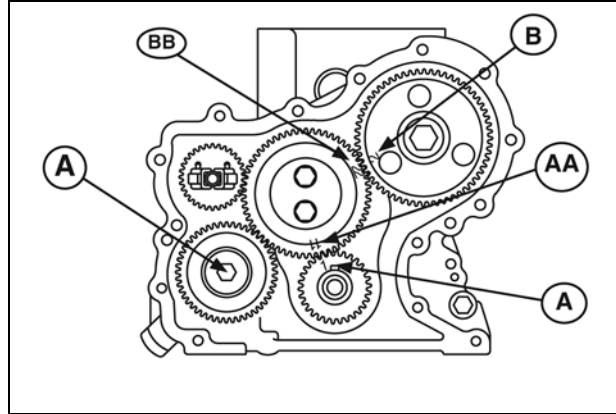

Figure 16

Engine models 430000 and 580000 built after date code 990111007 are equipped with right angle helical timing gears. Timing marks are identified by letters (A, AA, B, BB, etc.), instead of numbers. The timing procedure is the same.

7. With crankshaft key at the 12 o'clock position, assemble idler gear so that timing mark 11 (AA) is aligned with timing mark 1 (A) on crankshaft gear, timing mark 22 (BB) is aligned with timing mark 2 (B) on camshaft gear (Figure 17).

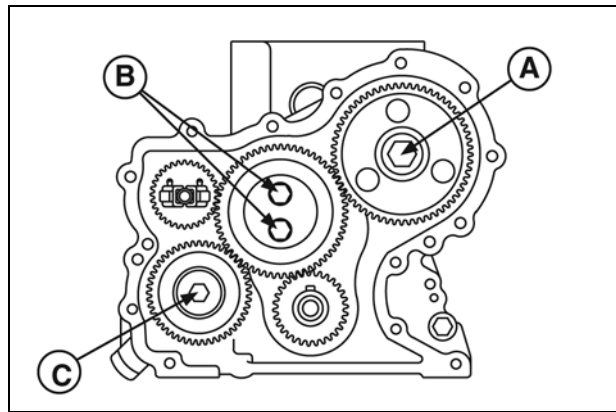

Figure 17

8. Install oil pump gear.
9. Torque screws to values listed in Section 14 - Engine Specifications. Camshaft gear (A, Figure 18), idler gear (B), and oil pump gear (C).

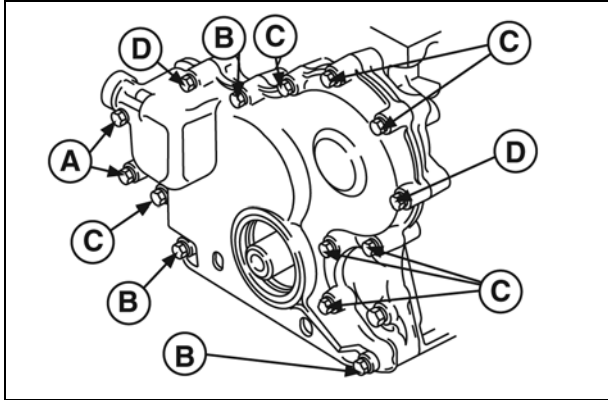

Figure 18

10. Install timing gear cover with new gasket.

Note position, length, and number of screws (Figure 19). Torque screws to values listed in Section 14 - Engine Specifications.

- M6 x 2.5 in. (M6 x 65 mm): 2 (A)
- M6 x 2.1 in. (M6 x 55 mm): 3 (B)
- M6 x 1.1 in. (M6 x 30 mm): 7 (C)
- M6 Nut: 2 (D)

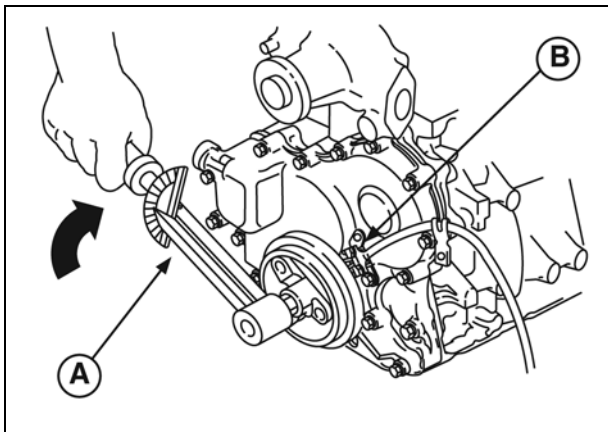

Figure 19

11. Install crankshaft pulley with timing mark at 12 o'clock position (No. 1 cylinder) (Figure 19).

NOTE: Ensure alignment pin in crankshaft gear is seated in hole in pulley.

12. Remove flywheel holder (A, Figure 20) AND install trigger assembly and wire (B).

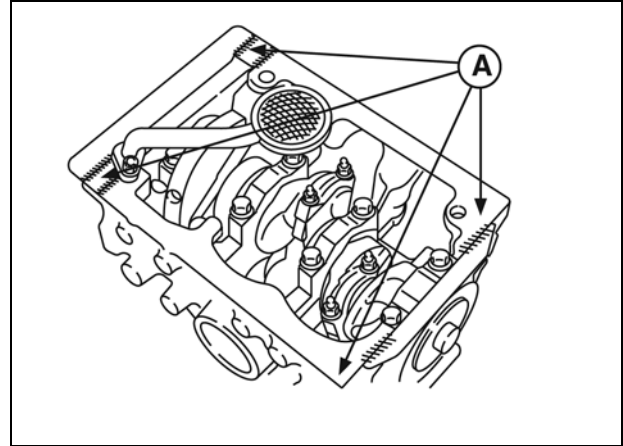

Figure 20

13. Install oil pick-up tube and strainer with new gasket.

14. Apply a small bead of Permatex® No. 2 or other similar sealant (A, Figure 21).

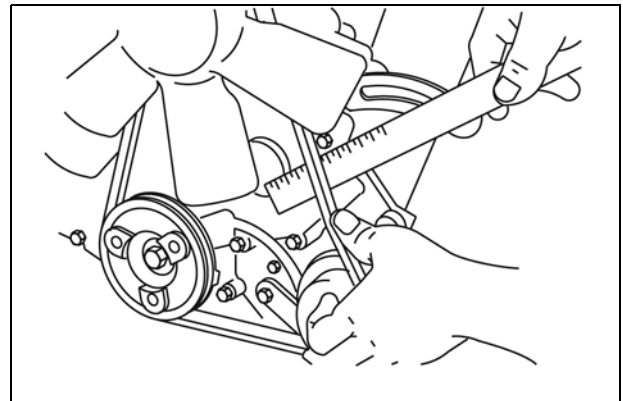

Figure 21

15. Install oil pan with new gasket. Torque screws and nuts to values shown in Section 14 - Engine Specifications.

16. Install V-belt and fan (if equipped).

17. Install governor lever (A, Figure 22) on to governor shaft. Do not tighten governor nut at this time.

18. Install governor link with spring (B).

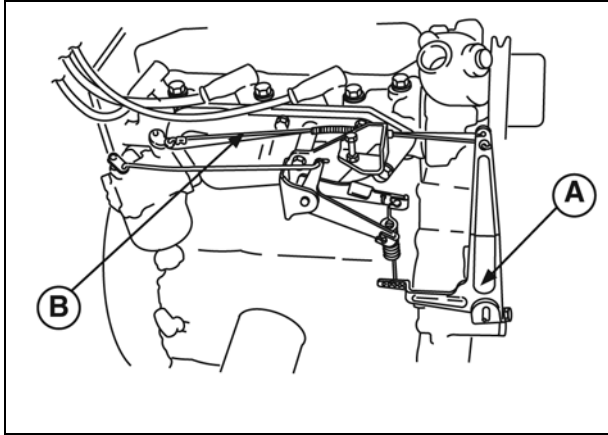

Figure 22

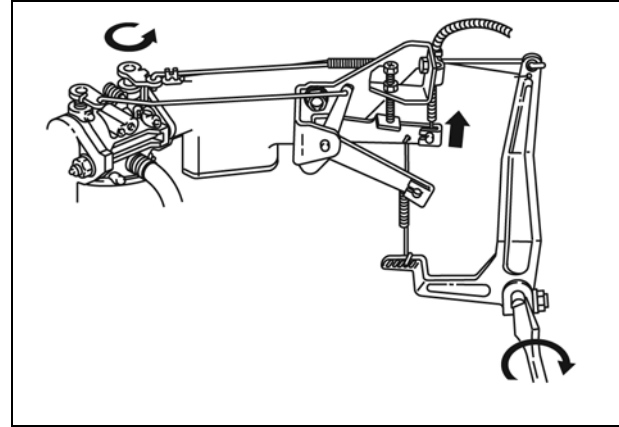

Figure 24

19. Insert governor spring into original hole in governor lever.

NOTICE: Governor spring must be installed in correct hole in governor control lever by engine model (Figure 23).

- Model 430400 - Top Hole
- Model 580400 - Bottom Hole

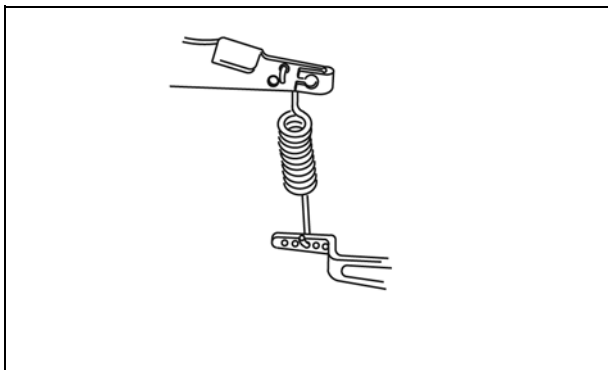

Figure 23

Adjust Governor

1. Move governor control lever (Figure 24) up to end of travel and hold in this position (throttle wide open).
2. Rotate governor shaft clockwise to end of travel.
3. Torque governor nut to value listed in Section 14 - Engine Specifications.

SECTION 13 - COOLING SYSTEM

GENERAL INFORMATION - - - - -	146
PRESSURE TEST COOLING SYSTEM - - - - -	147
CHANGE COOLANT - - - - -	147
TEST RADIATOR CAP - - - - -	147
REMOVE THERMOSTAT - - - - -	147
INSPECT THERMOSTAT - - - - -	148
INSTALL THERMOSTAT - - - - -	148
INSPECT WATER PUMP - - - - -	148
REMOVE WATER PUMP - - - - -	149
INSTALL WATER PUMP - - - - -	149

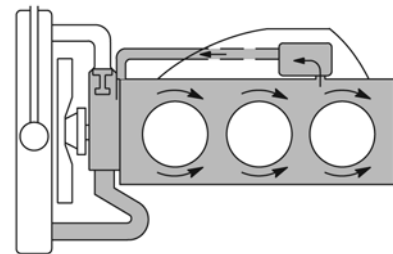

THERMOSTAT CLOSED

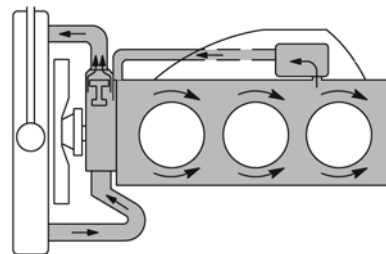

THERMOSTAT OPEN

General Information

Briggs & Stratton Daihatsu gasoline and diesel engines use a pressurized, forced circulation cooling system.

The water pump circulates coolant through the cylinder block, cylinder head, intake manifold, and radiator. The thermostat maintains optimum engine temperature.

The thermostat is equipped with a by-pass valve which permits coolant to re-circulate through the cylinder block, cylinder head, and pre-heat the intake manifold. Pre-heating the intake manifold promotes fuel and air mixture efficiency when the engine is cold.

As the engine warms, the by-pass valve closes as the thermostat opens, permitting complete circulation through the radiator.

Always maintain a 50% solution of phosphate free antifreeze at all times for adequate heat dissipation, lubrication, and protection from freezing.



WARNING

The cooling system is pressurized. Do not remove the radiator cap while the engine is hot. To avoid scalding hot coolant or steam blowing out of the radiator, use extreme care when removing the radiator cap. If possible, wait for engine to cool. Wrap a thick rag around the cap while removing. To release pressure, slowly turn cap counterclockwise to the first stop. When all pressure has been released, press down on cap and continue turning.

Pressure Testing Cooling System

1. Remove radiator cap and make sure coolant is at correct level.

NOTE: Coolant level must be no more than 25 mm (1 in.) below bottom of filler neck.

2. Install cooling system pressure tester on radiator and pressurize system to 0.75 Bar (11 psi).

NOTE: System must maintain pressure during test

3. Check the following for any signs of leaking:
 - Hoses and connections (also check hoses for excessive bulging).
 - Radiator
 - Water Pump
 - Intake manifold and by-pass hose.
 - Freeze plugs (cylinder block and cylinder head)
4. If system does not maintain pressure and no leaks are evident externally, check for an internal leak such as a blown head gasket, warped cylinder head or cylinder block.

Change Coolant

NOTE: Coolant should be changed once a year. Change coolant with engine cold.

1. Remove radiator cap. Remove radiator drain plug (A, Figure 1) and drain the system.

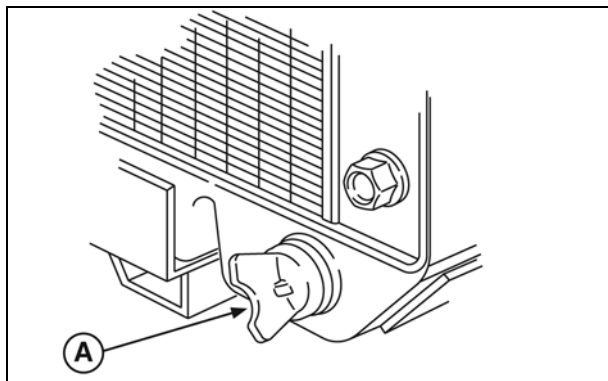

Figure 1

2. Tighten drain plug.

NOTE: Follow state or federal laws regarding the proper procedure for disposing of antifreeze.

Test Radiator Cap

1. Ensure that the rubber seal on the radiator cap is not damaged or distorted. Rubber seals must be clean and free of debris to seal properly.
2. Install radiator cap on pressure tester and pressurize the cap.
 - Specification: 1.03 ~ 0.75 Bar (15 ~ 11 psi). Recommended pressure cap capacity is 0.9 Bar (13 psi).
3. Replace cap if not within specifications.
4. Fill radiator with 50% solution of phosphate free antifreeze.
5. Start and run engine until thermostat opens (when coolant level drops, thermostat is open).
6. Check coolant level in radiator (A, Figure 2) and add coolant as required.

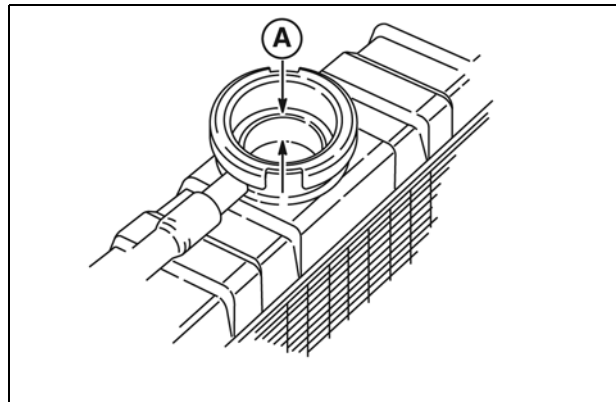

Figure 2

7. Install radiator cap.

Remove Thermostat - Engine Cold

1. Drain engine coolant.
2. Remove screws and coolant outlet housing (A, Figure 3).
3. Remove locating screw (B) and thermostat (C).
4. Remove all traces of gasket material.

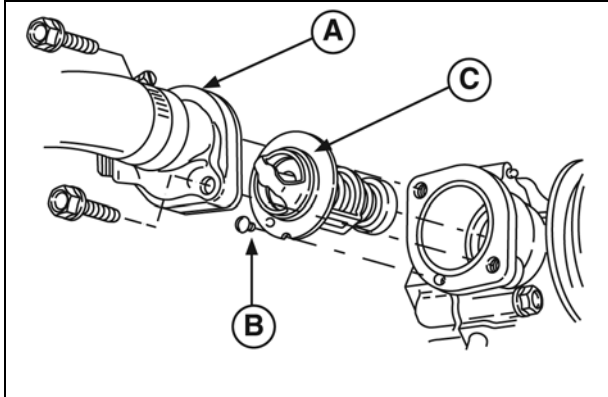

Figure 3

Inspect Thermostat

NOTE: A thermostat capable of reading 210 °F (100 °C) or more is required.

1. Check to make sure thermostat valve is fully closed.
2. Immerse thermostat in water and heat water gradually (Figure 4).

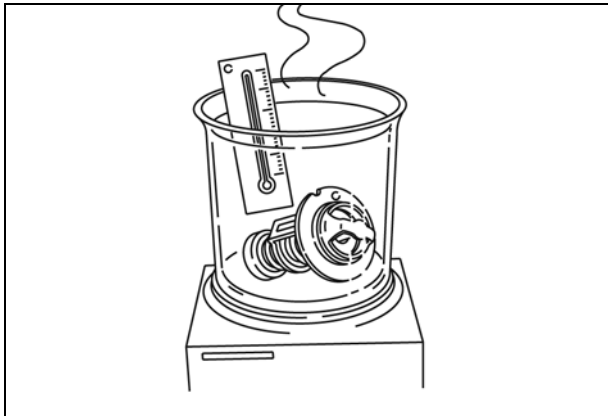

Figure 4

3. Note temperature when thermostat starts to open.
 - 178 ~ 183° F (81~84 °C)
4. Note temperature when thermostat is fully open.
 - 203 °F (95 °C)
5. Remove thermostat from water and allow to cool.
6. Thermostat should close fully.

Install Thermostat

1. Insert thermostat in housing and install locating screw (A, Figure 5).

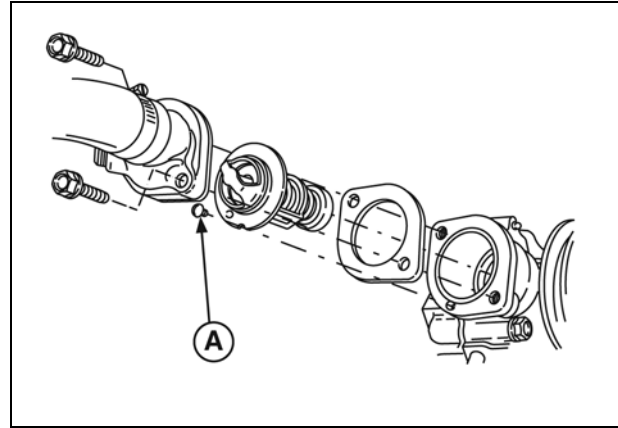

Figure 5

2. Install coolant outlet housing with new gasket.
3. Torque screws to values listed in Section 14 - Specifications.
4. Refill with coolant.

Inspect Water Pump

1. Inspect water pump for signs of leaking at vent holes (A, Figure 6), mounting surfaces, and water pump pulley shaft.

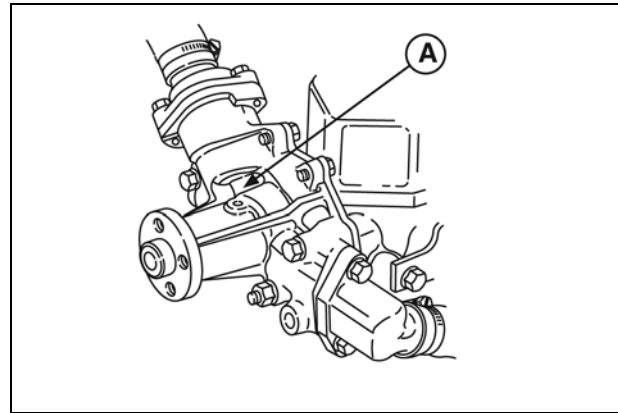

Figure 6

2. Remove V belt, alternator adjustment bracket, fan (if equipped), and water pump pulley. Replace pulley if bent or damaged.
3. Check water pump bearings by rotating pulley flange by hand (Figure 7). Make sure pulley rotates smoothly.

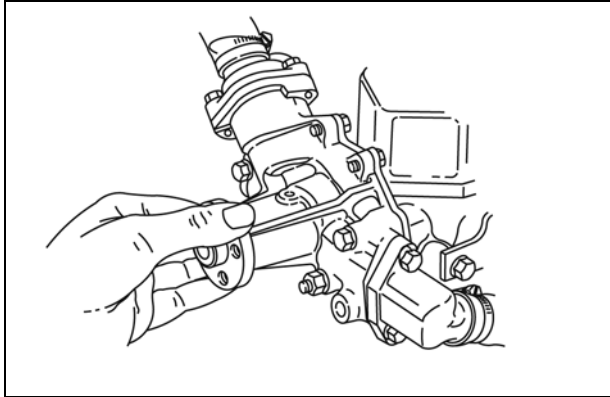

Figure 7

4. If water pump shows evidence of leaking or if the bearings are rough, replace the water pump.

NOTE: Most water pump and cooling system failures result from using straight water as a coolant. Without water pump lubricant and corrosion inhibitors, the water pump will fail prematurely.

Remove Water Pump

1. Drain engine coolant.
2. Disconnect radiator hoses (Figure 8).

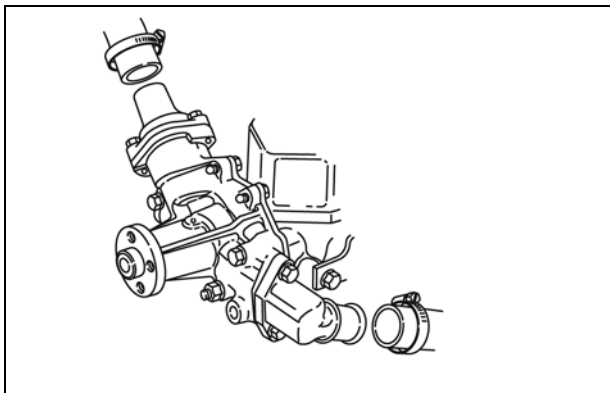

Figure 8

3. Remove the following parts (Figure 9):
 - (A) By-pass hose
 - (B) Temperature gauge wire (if equipped)
 - (C) Coolant outlet
 - (D) Coolant inlet
 - (E) Water pump

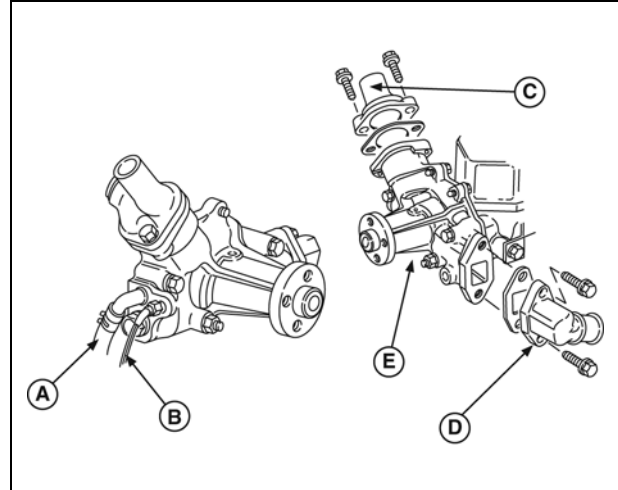

Figure 9

4. Clean all traces of gasket material from mounting surfaces and inspect mounting surfaces for damage.

Install Water Pump

1. Install water pump with new gasket (Figure 10). Torque screws to values listed in Section 14 - Specifications.

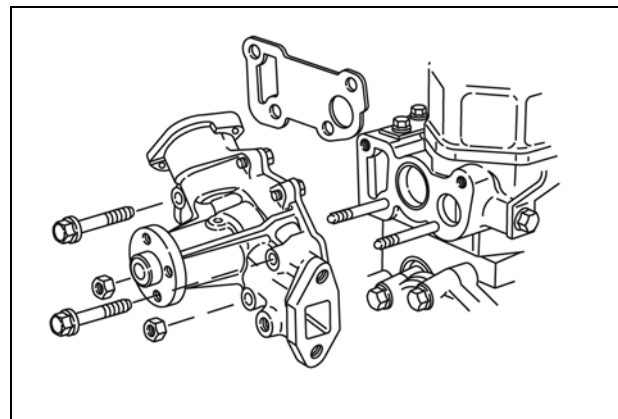

Figure 10

2. After installing water pump, ensure that pump rotates smoothly.
3. Install coolant inlet with new gasket (Figure 11). Torque screws to values listed in Section 14 - Engine Specifications.
4. Install thermostat and coolant outlet with new gasket. Torque screws to values listed in Section 14 - Engine Specifications.
5. Install bypass hose.
6. Install temperature gauge wire (if equipped).

7. Install radiator hoses.

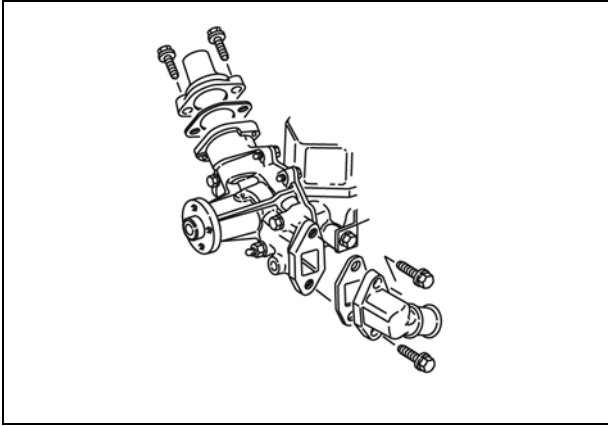

Figure 11

8. Install fan (Figure 12) (if equipped) and water pump pulley. Torque screws to values listed in Section 14 - Engine Specifications.

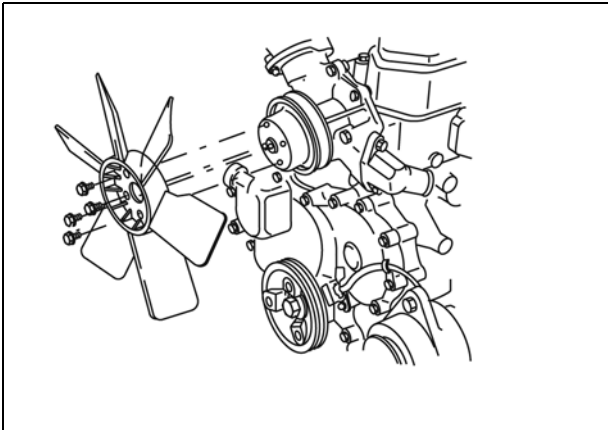

Figure 12

9. Install V belt (Figure 13).

- Belt tension adjustment: 3/8 - 1/2 in./22lb. (10.0 - 12.0 mm/10 kg).

10. Refill cooling system.

SECTION 14 - ENGINE SPECIFICATIONS

MODEL 430000	152
MODEL 580000	154

MODELS 430000

ENGINE SPECIFICATIONS	
Spark Plug Gap	0.030 in. (0.76 mm)
Valve Clearance – Intake	0.007 in. (0.18 mm)
Valve Clearance – Exhaust	0.007 in. (0.18 mm)
FASTENER TORQUE SPECIFICATIONS	TORQUE
Alternator Adjustment Bracket	170 in. lbs. (19 Nm)
Alternator (to bracket)	170 in. lbs. (19 Nm)
Alternator Bracket (to block)	170 in. lbs. (19 Nm)
Camshaft Gear	30 ft. lbs. (41 Nm)
Camshaft Retainer	70 in. lbs. (8 Nm)
Carburetor (to manifold)	70 in. lbs. (8 Nm)
Coil Bracket	180 in. lbs. (20 Nm)
Connecting Rod Nuts	320 in. lbs. (36 Nm)
Crankshaft Pulley	65 ft. lbs. (88 Nm)
Cylinder Head Bolts (8 mm diameter)	25 ft. lbs. (34 Nm)
Cylinder Head Bolts (9 mm diameter)	26 ft. lbs. (35 Nm)
Exhaust Manifold	170 in. lbs. (19 Nm)
Fan Pulley	60 in. lbs. (7 Nm)
Flywheel	35 ft. lbs. (47 Nm)
Governor Actuator	70 in. lbs. (8 Nm)
Governor Control Bracket	70 in. lbs. (8 Nm)
Governor Nut	90 in. lbs. (10 Nm)
Governor Paddle	8 in. lbs. (1 Nm)
Idler Gear	220 in. lbs. (25 Nm)
Intake Manifold	60 in. lbs. (7 Nm)
Main Bearing Screws	45 ft. lbs. (61 Nm)
Oil Drain Plug	220 in. lbs. (25 Nm)
Oil Pan	70 in. lbs. (8 Nm)
Oil Pressure Relief Valve	25 ft. lbs. (34 Nm)
Oil Pump Gear	170 in. lbs. (19 Nm)
Oil Pump Pickup	70 in. lbs. (8 Nm)
Rear Seal Support	50 in. lbs. (6 Nm)
Rocker Arm Assembly	170 in. lbs. (19 Nm)
Rocker Arm Adjustment	95 in. lbs. (11 Nm)
Rocker Arm Studs	180 in. lbs. (20 Nm)
Spark Plugs	180 in. lbs. (20 Nm)
Starter	30 ft. lbs. (40 Nm)
Starter Bracket	25 ft. lbs. (34 Nm)
Starter Solenoid	70 in. lbs. (8 Nm)
Starter Thru Bolts	70 in. lbs. (8 Nm)
Timing Gear Case	70 in. lbs. (8 Nm)
Timing Gear Cover (3 different lengths)	70 in. lbs. (8 Nm)
Valve Cover	50 in. lbs. (6 Nm)
Valve Adjustment Screws	95 in. lbs. (11 Nm)
Water Pump	170 in. lbs. (19 Nm)

REJECT DIMENSIONS	STANDARD SIZE	REJECT SIZE
Camshaft Journals		
Front	1.415 - 1.416 in. (35.96 - 35.98 mm)	1.413 in. (35.89 mm)
Center	1.413 - 1.415 in. (35.91 - 35.96 mm)	1.411 in. (35.84 mm)
Rear	1.413 - 1.415 in. (35.91 - 35.96 mm)	1.411 in. (35.84 mm)
Camshaft Lobe Height		
Intake	1.183 - 1.186 in. (30.07 - 30.14 mm)	1.179" (29.97 mm)
Exhaust	1.183 - 1.186 in. (30.07 - 30.14 mm)	1.179" (29.97 mm)
Connecting Rod Bearing Clearance	0.0008 - 0.0017 in. (0.020 - 0.044 mm)	0.0028 " (0.07 mm)
Crankshaft		
End Play	0.0008 - 0.009 in. (0.020 - 0.23 mm)	0.0028 in. (0.07 mm)
Main Bearing	1.653 - 1.654 in. (41.98 - 42.00 mm)	
Crankpin	1.456 - 1.457 in. (36.98 - 37.00 mm)	
Cylinder		
Main Bearing	0.0008 - 0.0017 in. (0.020 - 0.044 mm)	0.0028 in. (0.07 mm)
Bore Diameter	2.67 - 2.68 in. (68.00 - 38.03 mm)	
Bore Out-of-Round	N/A	.0015 in. (.04 mm)
Cylinder Head		
Valve Guide	0.435 in. (11.05 mm)	
Intake Valve Stem Diameter		0.2343 in. (5.95 mm)
Exhaust Valve Stem Diameter		0.2342 in. (5.948 mm)
Idler Gear		1.345 in. (34.17 mm)
Piston		
Piston Pin		0.708 in. (17.98 mm)
Piston Pin Bearing		0.708 in. (17.98 mm)
Rotor Slip Ring Diameter	0.567 in. (14.40 mm)	0.551 in. (14.0 mm)
Rotor Brushes	0.413 in. (10.5 mm)	0.315 in. (8.0 mm)
Valve Lifter	0.708 in. (17.98 mm)	0.705 in. (17.91 mm)
Valve Lifter Bore	0.710 in. (18.02 mm)	0.711 in. (18.05 mm)

MODELS 580000

14

ENGINE SPECIFICATIONS	
Spark Plug Gap	0.030 in. (0.76 mm)
Valve Clearance – Intake	0.007 in. (0.18 mm)
Valve Clearance – Exhaust	0.007 in. (0.18 mm)
FASTENER TORQUE SPECIFICATIONS	TORQUE
Alternator Adjustment Bracket	170 in. lbs. (19 Nm)
Alternator (to bracket)	170 in. lbs. (19 Nm)
Alternator Bracket (to block)	170 in. lbs. (19 Nm)
Camshaft Gear	30 ft. lbs. (41 Nm)
Camshaft Retainer	70 in. lbs. (8 Nm)
Carburetor (to manifold)	70 in. lbs. (8 Nm)
Coil Bracket	180 in. lbs. (20 Nm)
Connecting Rod Nuts	320 in. lbs. (36 Nm)
Crankshaft Pulley	65 ft. lbs. (88 Nm)
Cylinder Head Bolts (8 mm diameter)	25 ft. lbs. (34 Nm)
Cylinder Head Bolts (9 mm diameter)	26 ft. lbs. (35 Nm)
Exhaust Manifold	170 in. lbs. (19 Nm)
Fan Pulley	60 in. lbs. (7 Nm)
Flywheel	35 ft. lbs. (47 Nm)
Governor Actuator	70 in. lbs. (8 Nm)
Governor Control Bracket	70 in. lbs. (8 Nm)
Governor Nut	90 in. lbs. (10 Nm)
Governor Paddle	8 in. lbs. (1 Nm)
Idler Gear	220 in. lbs. (25 Nm)
Intake Manifold	60 in. lbs. (7 Nm)
Main Bearing Screws	45 ft. lbs. (61 Nm)
Oil Drain Plug	220 in. lbs. (25 Nm)
Oil Pan	70 in. lbs. (8 Nm)
Oil Pressure Relief Valve	25 ft. lbs. (34 Nm)
Oil Pump Gear	170 in. lbs. (19 Nm)
Oil Pump Pickup	70 in. lbs. (8 Nm)
Rear Seal Support	50 in. lbs. (6 Nm)
Rocker Arm Assembly	170 in. lbs. (19 Nm)
Rocker Arm Adjustment	95 in. lbs. (11 Nm)
Rocker Arm Studs	180 in. lbs. (20 Nm)
Spark Plugs	180 in. lbs. (20 Nm)
Starter	30 ft. lbs. (40 Nm)
Starter Bracket	25 ft. lbs. (34 Nm)
Starter Solenoid	70 in. lbs. (8 Nm)
Starter Thru Bolts	70 in. lbs. (8 Nm)
Timing Gear Case	70 in. lbs. (8 Nm)
Timing Gear Cover (3 different lengths)	70 in. lbs. (8 Nm)
Valve Cover	50 in. lbs. (6 Nm)
Valve Adjustment Screws	95 in. lbs. (11 Nm)
Water Pump	170 in. lbs. (19 Nm)

REJECT DIMENSIONS	STANDARD SIZE	REJECT SIZE
Camshaft Journals		
Front	1.415 - 1.416 in. (35.96 - 35.98 mm)	1.413 in. (35.89 mm)
Center	1.413 - 1.415 in. (35.91 - 35.96 mm)	1.411 in. (35.84 mm)
Rear	1.413 - 1.415 in. (35.91 - 35.96 mm)	1.411 in. (35.84 mm)
Camshaft Lobe Height		
Intake	1.183 - 1.186 in. (30.07 - 30.14 mm)	1.179" (29.97 mm)
Exhaust	1.183 - 1.186 in. (30.07 - 30.14 mm)	1.179" (29.97 mm)
Connecting Rod Bearing Clearance	0.0008 - 0.0017 in. (0.020 - 0.044 mm)	0.0028 " (0.07 mm)
Crankshaft		
End Play	0.0008 - 0.009 in. (0.020 - 0.23 mm)	0.0028 in. (0.07 mm)
Main Bearing	1.653 - 1.654 in. (41.98 - 42.00 mm)	
Crankpin	1.456 - 1.457 in. (36.98 - 37.00 mm)	
Cylinder		
Main Bearing	0.0008 - 0.0017 in. (0.020 - 0.044 mm)	0.0028 in. (0.07 mm)
Bore Diameter	2.83 - 2.84 in. (72.00 - 72.03 mm)	
Bore Out-of-Round	N/A	.0015 in. (.04 mm)
Cylinder Head		
Valve Guide	0.435 in. (11.05 mm)	
Intake Valve Stem Diameter		0.2343 in. (5.95 mm)
Exhaust Valve Stem Diameter		0.2342 in. (5.948 mm)
Idler Gear		1.345 in. (34.17 mm)
Piston		
Piston Pin		0.708 in. (17.98 mm)
Piston Pin Bearing		0.708 in. (17.98 mm)
Rotor Slip Ring Diameter	0.567 in. (14.40 mm)	0.551 in. (14.0 mm)
Rotor Brushes	0.413 in. (10.5 mm)	0.315 in. (8.0 mm)
Valve Lifter	0.708 in. (17.98 mm)	0.705 in. (17.91 mm)
Valve Lifter Bore	0.710 in. (18.02 mm)	0.711 in. (18.05 mm)

