

Parts Manual

Mfg. No: 5902056
500S Series w/ 61" Mower Deck
(500SKAV2461)



5601077 - Service Jack Mount Kit (10").....

5601080 - Service Jack Kit.....

5601381 - Mulch Kit for 500s ZTR w/ 61" Deck.....

5601392 - Kit, 2-Bag Clean Sweep, Turbo, 500-61.....

Not For
Reproduction

Model Components	Page
61" Mower Deck - Housing, Arbors & Blade Group.....	4
61" Mower Deck - Pulleys, Belt, and Idler Arm.....	6
Body & Fuel Tank Group.....	8
Controls Group.....	10
Decal Group - Brand and Model.....	12
Decal Group - Safety and Operation.....	14
Electrical Group.....	16
Electrical Schematic - Charging Circuit - Kawasaki FR730V.....	18
Electrical Schematic - Cranking Circuit - Kawasaki FR730V.....	20
Electrical Schematic - Ignition Grounding Circuit/Op. Pres. - Kawasaki FR730V.....	22
Electrical Schematic - PTO Clutch Circuit - Kawasaki FR730V.....	24
Engine and PTO Group.....	26
Evap Group.....	28
Frame, Pivoting Front Axle, Floor Pan, and Bumper Group.....	30
Lift Group.....	32
Parking Brake Group.....	34
Rear Suspension Group.....	36
Seat Group.....	38
Transmission Group - Suspension.....	40
Wheel & Tire Group.....	42
Torque Specification Chart.....	44

Not For
Reproduction

61" Mower Deck - Housing, Arbors & Blade Group

Note: Unless noted otherwise, use the standard torque specifications

Mfg. No: 5902056

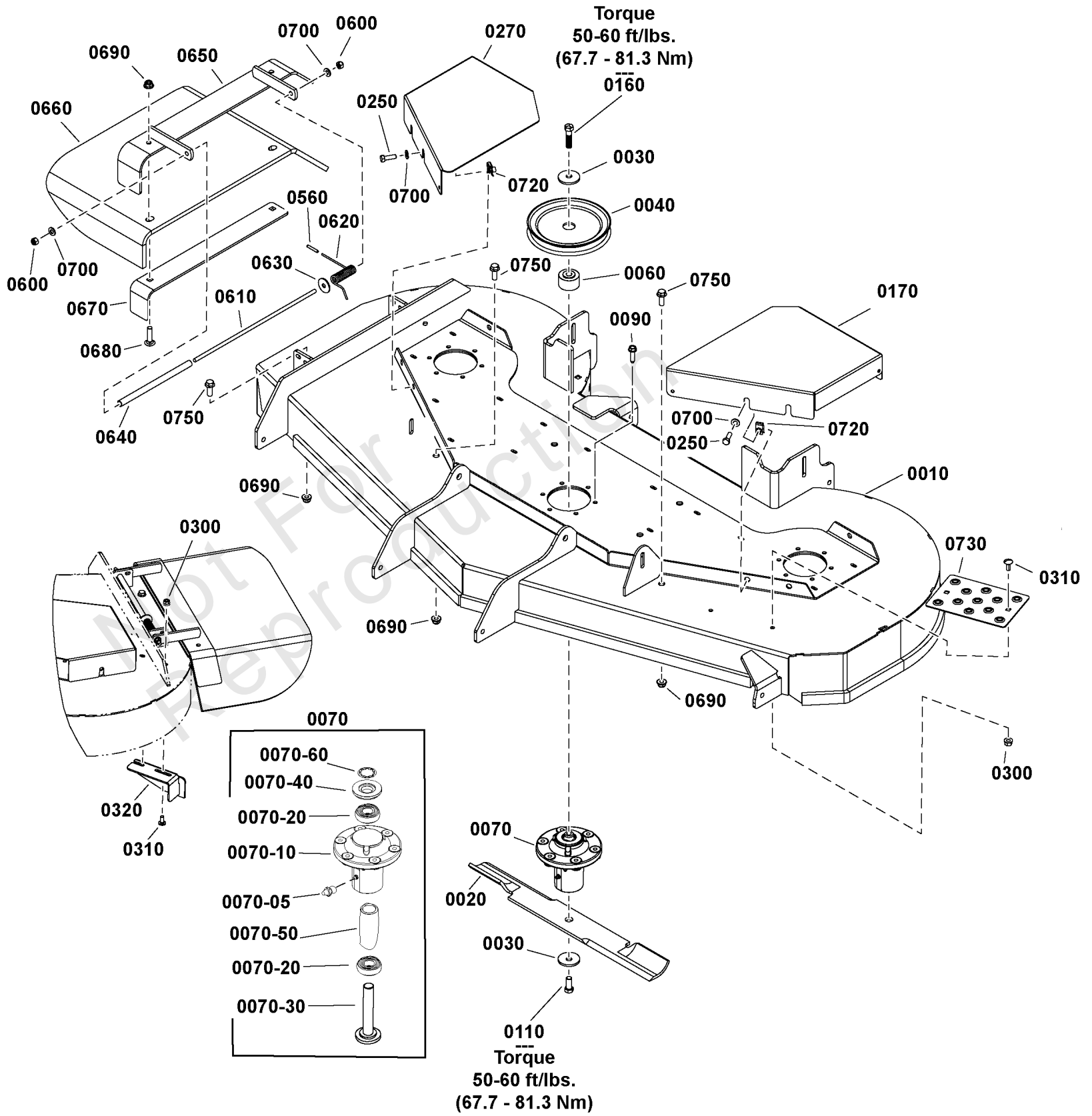

61" Mower Deck - Housing, Arbors & Blade Group

REF NO	PART NO	QTY	DESCRIPTION
0010	5601357	1	DECK SHELL W/DECALS, 500S-61 (80091751B)
0020	5104045S	1	BLADE SET, 61 DECK, 3/16 (3) -(Set of 3 blades)
0030	1656916	6	WASHER, .475 ID x 1.75 OD x .156 Thick Spring, Black
0040	80092024	3	PULLEY, SPINDLE, 7.000 OD
0060	1758624	3	SPACER, HUB
0070	1761761	3	ARBOR ASSEMBLY 52 FAB
0070-05	1704314	1	LUBE FITTING, 1/4 Drive , Check Ball -(One per arbor)
0070-10	1761739	1	HOUSING, SPINDLE - CAST ALUM W/ ZERK -(One per arbor)
0070-20	1735399	2	BEARING, BALL, 20MM 46" MWR -(Two per arbor)
0070-30	1761746	1	SHAFT, MOWER SPINDLE-.620 BLADE PILOT -(One per arbor)
0070-40	1761742	1	SHIELD-ARBOR 2.050 OD -(One per arbor)
0070-50	1761743	1	SPACER - BEARING MIDDLE -(One per arbor)
0070-60	1960766	1	RING, Self-Locking, 46" Mower -(One per arbor)
0090	80003681	18	SCREW, Hex Washer Head Taptite 5/16-18 x 1-1/4
0110	80004484	3	HHCS, 7/16-14 X 1.250
0160	80100544	3	CAPSCREW, Hex Head, 7/16-14 X 2
0170	80097542AA	1	COVER, LH ARBOR (61 HOZ-XT) BLK TXTRD
0250	5025011X6	6	BOLT, 5/16-18 X 3/4 GD5
0270	80097541AA	1	COVER, RH ARBOR (61 HOZ-XT) BLK TXTRD
0300	5025392	4	NUT, 5/16-18 HEX NYLOCK FLANGE NUT
0310	5025145X6	4	BOLT, 5/16-18 X 3/4, CARRIAGE, GD5, CZ
0320	5401344AA	1	PLATE, DEFLECOR - BLK
0560	5023489	1	CAP, PROTECTOR, .120 ID
0600	5025045	2	NUT, 5/16-24 HEX NYLON LOCK
0610	5042555	1	ROD, 5/16 X 13.75, TBE, CZ
0620	5023385	1	SPRING, TORSION
0630	5025164	1	WASHER, 5/16" Fender
0640	5050086X8	1	TUBE, 1/2 X 3/8 BLACK POLY, 8.00 LG
0650	5413404AA	1	WELD, MOUNT, DISCHARGE CHUTE - BLK
0660	5413498	1	CHUTE, RUBBER DISCHARGE CHUTE (5104441)
0670	5413401AA	1	NLA - SUPPORT, DISCHARGE CHUTE - BLK
0680	5025146X12	2	BOLT, 3/8-16 X 1-1/2, CARRIAGE, GD5, CZ
0690	5025394	4	NUT, 3/8 - 16 HEX NYLOCK FLANGE
0700	5025155	8	WASHER, 5/16" SAE
0720	5022308	6	BODY CLIP, 5/16-18-7GA MATERIAL
0730	80096682AA	1	STEP, MOWER DECK, BLACK
0750	80003585	2	BOLT,3/8-16X.75,GR5,CARRIAGE,ZC/CL

61" Mower Deck - Pulleys, Belt, and Idler Arm

Note: Unless noted otherwise, use the standard torque specifications

Mfg. No: 5902056

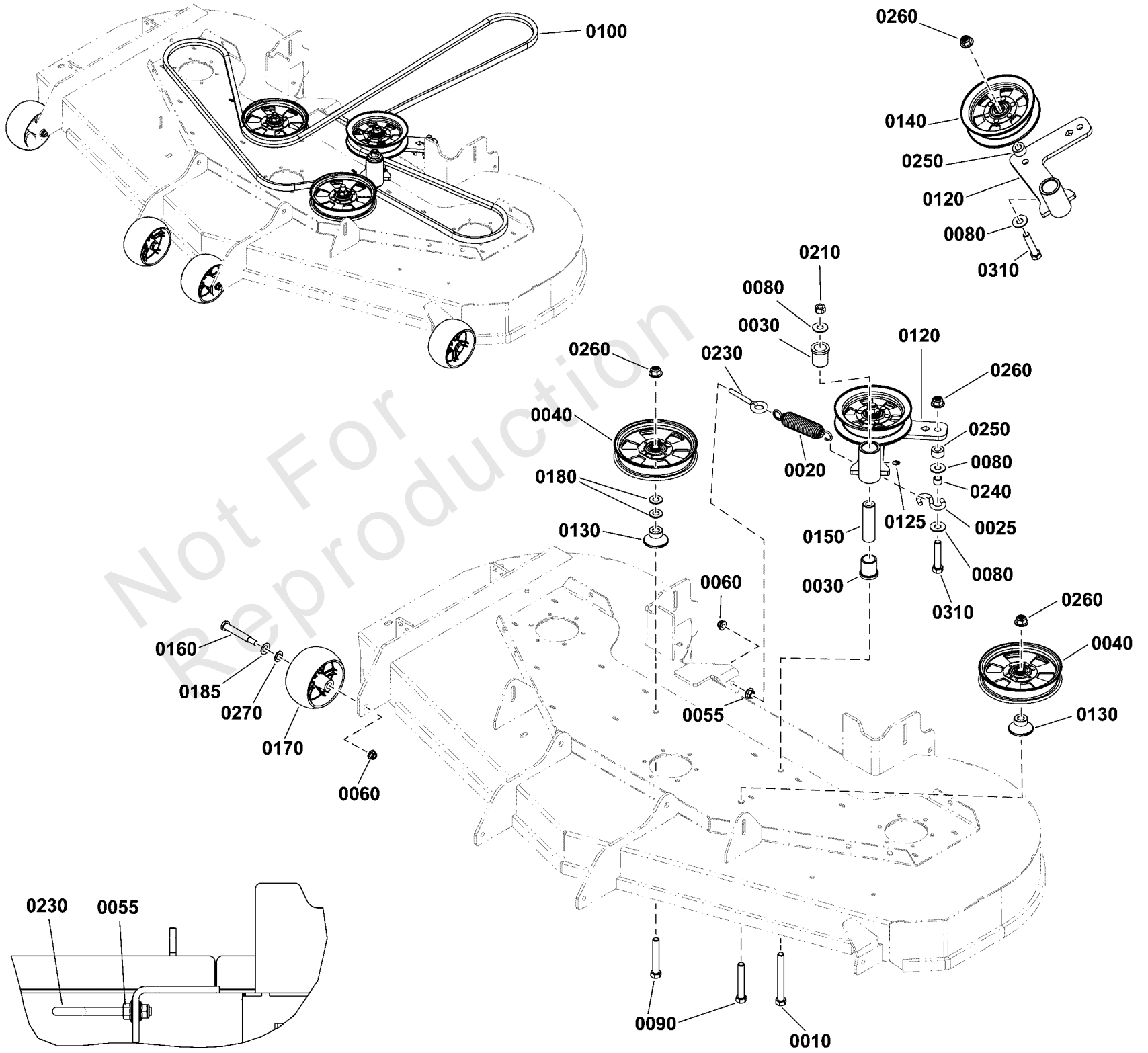

61" Mower Deck - Pulleys, Belt, and Idler Arm

REF NO	PART NO	QTY	DESCRIPTION
0010	5025017X36	1	BOLT, 1/2-13 X 4-1/2" GD5 YZ
0020	5100633	1	SPRING-EXT, 1.25 ODX5.70LGX.142WR, BLK
0025	5104011	1	HOOK, 5/16 S-HOOK, OPEN END, CZ
0030	5021541	2	BUSHING, FLANGE
0040	5104717	2	PULLEY, FLT IDLR, 6.0 X 1.0 X .50, CZ
0055	5025128	1	NUT, 3/8-16 Hex Large Serrated Flange
0060	5025394	5	NUT, 3/8 - 16 HEX NYLOCK FLANGE
0080	-----	4	WASHER, Flat
0090	5025017X26	2	BOLT, 1/2-13 X 3-1/4, HEX HD, GD5, CZ (SV)
0100	80093909	1	BELT, B-SECT, 164.2" EFL-ARAMID
0120	80098296AA	1	WELDMENT, IDLER ARM 61", BLACK
0125	5020095	1	GREASE FITTING, 1/4-28 Straight
0130	5103430	2	IDLER MOUNT
0140	5104716	1	PULLEY, IDLER, BACKSIDE, NOSEAM 6.25ODX.5ID
0150	5045022	1	SPACER, .52 x 1.00 x 3.50
0160	1736539	4	SHOULDER BOLT, 3/8-16 x 3.41" .750 Thread Yellow
0170	1736896	4	GAUGE WHEEL, Black Poly 5" Dia.
0180	5025158	2	WASHER, 1/2 SAE
0185	720035	4	WASHER, Spring, .30" ID
0210	5025332	1	NUT, 1/2-13 Hex Side Lock
0230	5025429	1	EYEBOLT, 3/8-16 X 4, 2.13THRD, .75EYE, C
0240	5020870	1	INSERT, Bearing
0250	5101162	2	SPACER, .52 X 1.00 X .56, PM, CZ
0260	5025396	4	NUT, Hex Flange, Nylock, 1/2-13
0270	80003590	4	WASHER, .516IDX.875ODX.06, FLAT, ZC/CL
0310	5025017X20	2	BOLT, 1/2-13 X 2-1/2" GD5 CZ

Body & Fuel Tank Group

REF NO	PART NO	QTY	DESCRIPTION
0010	1758077	1	FENDER, RH ZT (BLACK)
0020	1759369	1	ROD, UPPER FENDER SUPPORT
0030	7090999	1	SCREW, 1/4-20 x 5/8" Pan Head Self-Tap (Torx)
0045	80086902	1	ASSEMBLY, ZT FUEL TANK (W/ GAUGE) -(Includes item Nos. 0045-10 thru 0045-90)
0045-10	-----	1	TANK, Fuel -(Order item 0045)
0045-20	-----	1	NECK, Fuel Filter -(Order item 0045)
0045-30	1758314	1	CAP, FUEL (NON-VENTED) W/ 11.25" TETHER
0045-40	209043	1	GROMMET (SV)
0045-50	80019626	1	ASSY., REMOTE VENT - NO VALVE
0045-60	1758927	1	ASSY, FUEL PICKUP TUBE
0045-70	1726400	1	BUSHING-FUEL TANK RED RUBBER
0045-80	1758928	1	GAUGE, FUEL, 7.25"
0045-90	80089102	1	GROMMET, FUEL GAUGE
0050	197546	5	MNT, VBRTN, RBBR
0060	1758076	1	FENDER, LH ZT (BLACK)
0070	84007754	2	SUPPORT, Fender
0080	1761722A	1	BRACKET, SEAT SPRING MOUNT (BLACK)
0090	5022308	18	BODY CLIP, 5/16-18-7GA MATERIAL
0100	5025394	2	NUT, 3/8 - 16 HEX NYLOCK FLANGE
0110	5025390X8	2	BOLT, 3/8-16 X 1, FLANGE, GD 5, CZ
0120	1960044	4	WASHER, Plain, 21/64 x 1-1/4
0130	1759140A	1	BRKT, FUEL TANK STRAP (BLACK)
0140	1760244	2	SUPPORT, FUEL TANK
0150	80004190	2	SCREW, Hex Washer Head, Thread Roll, 1/4-20 x 5/8



Controls Group

REF NO	PART NO	QTY	DESCRIPTION
0010	1758372	2	HANDLE, CONTROL W/ GRIP
0020	5025392	4	NUT, 5/16-18 HEX NYLOCK FLANGE NUT
0030	80004473	4	BOLT,5/16-18X1.000,ROUND HD CRRG,ZC/CL
0040	1757965	2	ARM, UPPER CONTROL
0050	80012294	2	BOLT,SHLDR,5/16-18X.375DIA,GR5,ZINC/CLEA
0060	1757964	2	ARM, LOWER CONTROL
0070	2176440	4	BUSHING-0.765ID 0.885OD 0.877LG NYLON
0080	80005404	10	SCREW,5/16-18X0.625,WSHR,THD-ROLL,ZC/CL
0090	1758087AA	2	BRKT, INNER CONTROL PIVOT
0100	5022308	2	BODY CLIP, 5/16-18-7GA MATERIAL
0110	1758373	2	KNOB, 5/16-18 X 2.50" STUD
0120	1650347	2	SPRING-COMP 0.50 IDX 02.328LG .063WIRE D
0130	5025211	4	PIN, HAIR, .0585 X 1-1/8, 1/4 EYE, YZ
0140	1758463	2	ROD, DAMPNER MNT
0150	5105587	2	DAMPENER, 18MM X 70MM
0160	1759182	2	LATCH, CONTROL ARM
0170	80003579	4	BOLT,1/4-20X.75,GR5,RH SH SQ NK,ZNC/CLR
0180	5025391	4	NUT, 1/4-20 Hex Nylock Flange
0190	80012410	2	WASHER, 3 WAVE, .750" ID
0200	5025057	2	NUT, Hex, Nylon Locking, 5/16-18

Decal Group - Brand and Model

Note: Unless noted otherwise, use the standard torque specifications

Mfg. No: 5902056

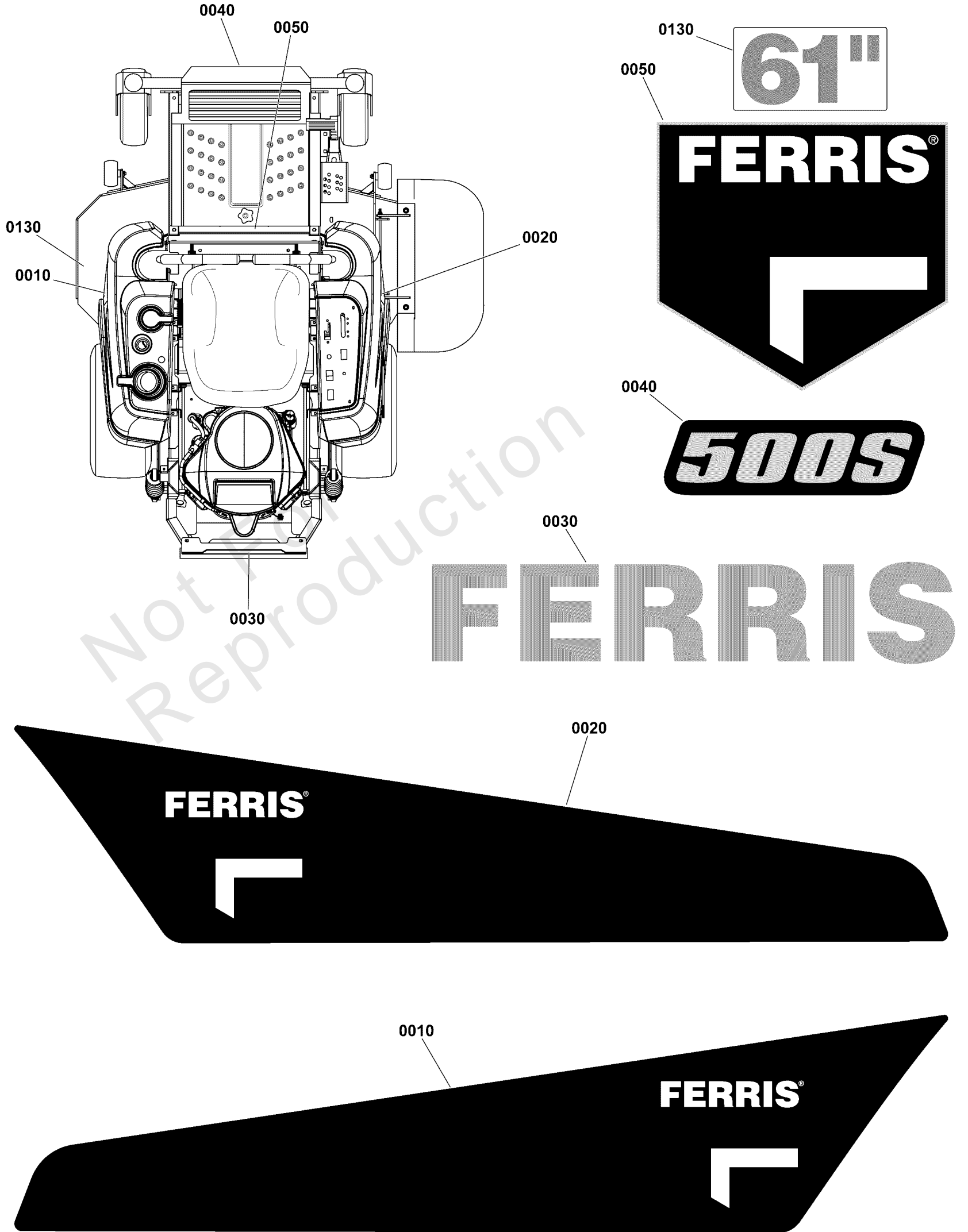

Decal Group - Brand and Model

REF NO	PART NO	QTY	DESCRIPTION
0010	80106105FS	1	DECAL, BRAND
0020	80106106FS	1	DECAL, BRAND
0030	80106081FS	1	DECAL, BRAND
0040	80106107FS	1	DECAL, Model
0050	5104724FS	1	DECAL, BRAND
0130	5022813SM	1	DECAL, 61

Not For Reproduction

Decal Group - Safety and Operation

Note: Unless noted otherwise, use the standard torque specifications

Mfg. No: 5902056

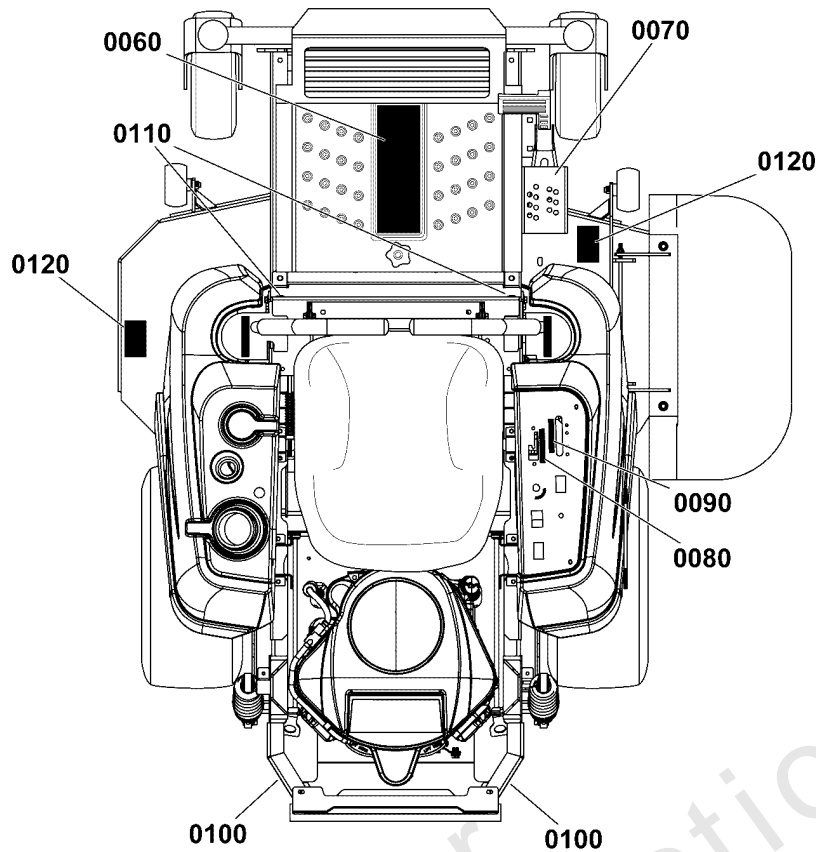

⚠ DANGER

Amputation hazard
Rotating blades cut off arms and legs.

- Stop the mower when children or others are near.
- Do not carry riders (especially children) even with the blades off. They may fall off or return for another ride when you are not expecting it.
- Look down, behind and to the side before changing directions.

Loss of control and roll-over hazard
Operating on slopes can be hazardous and cause loss of control and roll-overs.

- Do not operate on slopes over 10 degrees.
- Avoid sudden turns or rapid speed changes.
- Reduce speed and use extreme caution on slopes.
- Avoid turning down slopes; if possible turn up slopes.
- If machine stops forward motion on a slope, stop the blades and drive slowly off the slope.

Water, retaining walls and drop-off hazards
Wheels dropping over edges may result in serious injury, death or drowning.

- Do NOT operate down slope towards or near water, retaining walls or drop-offs.
- Give yourself a minimum of two mower widths of clearance around these hazards.

⚠ WARNING

Fire hazard
Gasoline is flammable. Yard debris is combustible.

- Allow engine to cool for at least 3 minutes before refueling.
- Keep unit cleaned of debris.
- This equipment may create sparks that can start fires around dry vegetation. A spark arrester may be required. Contact local fire agencies for regulations relating to fire prevention requirements.

Avoid serious injury or death
Read the operator's manual before using this product.

- Do NOT operate this machine unless you are trained.
- Know the location and function of all controls.
- Keep safety devices (guards, shields, switches, etc.) in place and working.
- Remove objects that could be thrown by the blade.
- Be sure blade(s) and engine are stopped before placing hands or feet near blade(s).
- When leaving machine, shut off, remove key, and set parking brake.

CAN ICES-2/NMB-2 510664-A

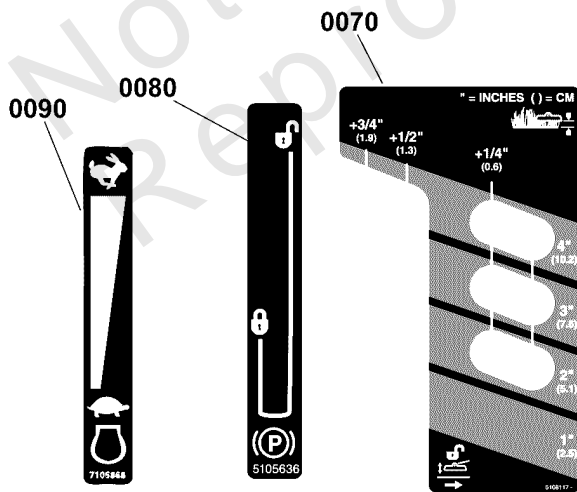

⚠ DANGER

Amputation and thrown objects hazard

- Keep hands and feet away from deck.
- Do not operate mower unless discharge chute or entire grass catcher is in its proper place.

7101666

0150

HYDRAULIC OIL

USE SAE 20W-50 MOTOR OIL

5100957

0140

Belts & Blades

Tractor	
Pump Drive Belt	80103769
48" Mower	
Deck Drive Belt	80105246
Mower Blade (Set)	1759056S
52" Mower	
Deck Drive Belt	80098314
Mower Blade (Set)	1756152S
61" Mower	
Deck Drive Belt	80093909
Mower Blade (Set)	5104045S

8010693 B

0160

The operator's manual is available in Spanish.
La manual del operador está disponible en Español.

CAN ICES-2/NMB-2

510286 B

0100

1

STOP

2

1

STOP

2

1759466

Decal Group - Safety and Operation

REF NO	PART NO	QTY	DESCRIPTION
0060	5106564	1	DECAL, MAIN SAFETY, SML ZTR
0070	5108117	1	DECAL, CUTTING HEIGHT
0080	5105636	1	DECAL, OPERATION, PARK BRAKE
0090	7105868	1	DECAL, ENGINE SPEED - NO CHOKE
0100	1759466	2	DECAL, TOW VALVE RELEASE (SUSP)
0110	1759724	2	DECAL, TRACKING ADJUSTMENT - ZT
0120	7101665	2	DECAL, DANGER DO NOT OPERATE W/O DEFLECT
0140	80106630	1	DECAL, FERRIS SERVICE, 48"/52"/61" ZT -(Located on the bottom of seat plate.)
0150	5100957	1	DECAL, HYDRAULIC OIL, SAE 20W50 -(Located on the bottom of seat plate.)
0160	5104269	1	DECAL, SPANISH MANUAL, IGES, C-TICK -(Located on left frame rail near front of fuel tank.)

Not For Reproduction

Electrical Group

Note: Unless noted otherwise, use the standard torque specifications

Mfg. No: 5902056

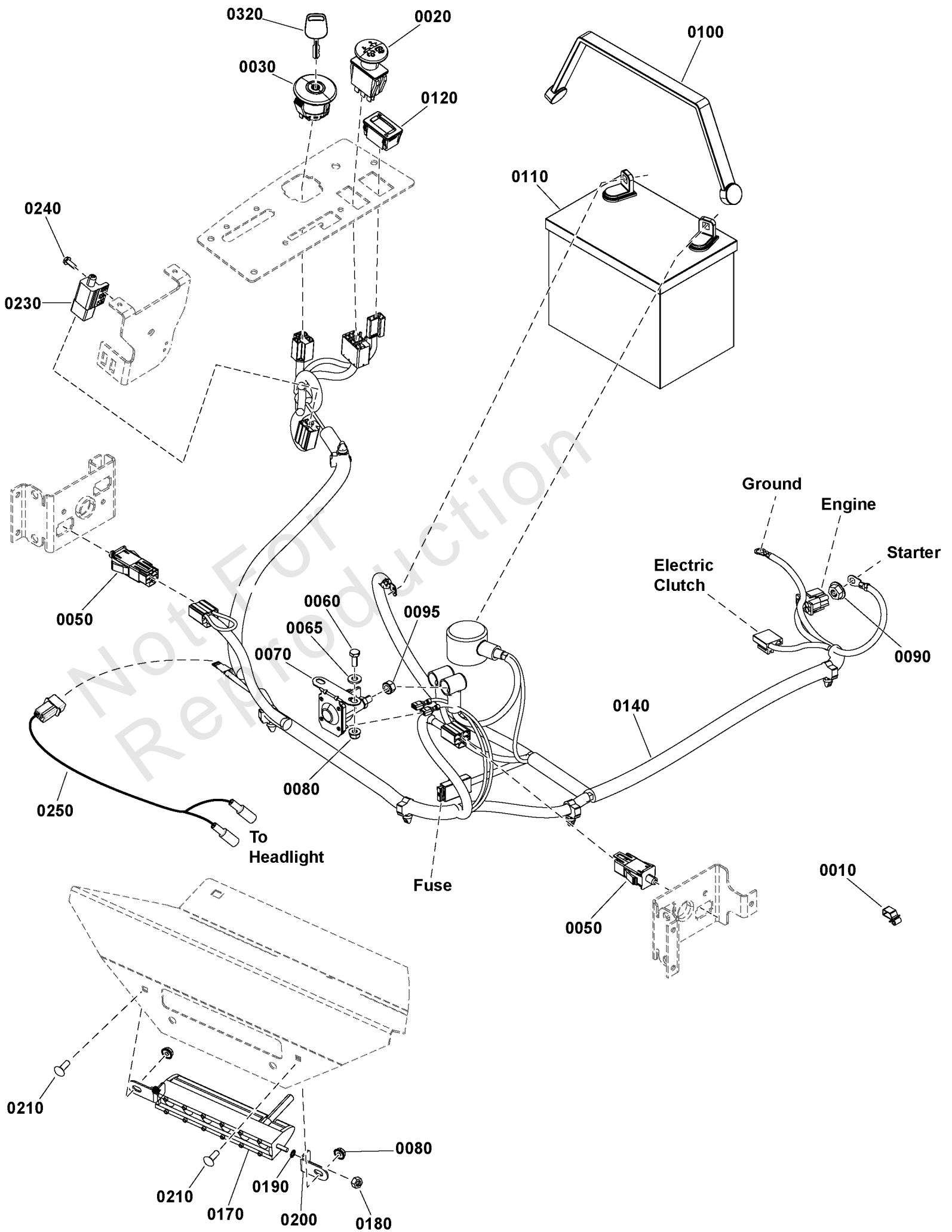

Electrical Group

REF NO	PART NO	QTY	DESCRIPTION
0010	2172434	3	CLIP, Wire
0020	1722887	1	SWITCH-PTO PUSH
0030	7106169	1	SWITCH, IGNITION, DELTA, (3 POSITION)
0050	7022886	2	SWITCH, DP NO/NC SNAP-IN
0060	-----	2	HHCS, 1/4-20 X 0.625, GR5, ZINC/CLEAR
0065	5025154	2	WASHER, 1/4 SAE
0070	1755381	1	SOLENOID, L-BRACKET, 2-SPADE
0080	5025391	4	NUT, 1/4-20 Hex Nylock Flange
0090	80003921	1	NUT,1/4-20,KEPS,CONICAL WSHR,ZC/CL
0095	2860750	2	NUT, Hex Locking, KEPS, 5/16-24
0100	1722009	1	STRAP, BATTERY, 14 LONG, Rubber
0110	-----	1	BATTERY, 12 VOLT, 230 CCA
0120	1731185	1	HOUR METER, Digital, No Alarms
0140	80097605	1	HARNESS, WIRING, XT MAIN (ZT) -(Includes item # 0140-10.)
0140-10	5021603	1	FUSE, ATO-20 (20 AMP)(SV) -(Not illustrated.)
0170	5420644	1	HEADLIGHT ASSY - LED
0180	5025672	2	NUT, HEX, M5X.8MM, NYLON INSERT
0190	5025673	2	WASHER, 5MM, STAR, CZ
0200	5107389AA	2	BRACKET, L HEADLIGHT MOUNT - BLK
0210	80003518	2	BOLT,1/4-20X0.750,GR5,STD NECK,SQ,ZC/CL
0230	1717050	1	SWITCH, PLUNGER, N.O./N.C.
0240	80005972	2	SCREW,#10-24X0.50,HEX WSHR,TORX,TT,ZC/CL
0250	80097608	1	HARNESS, HEADLIGHT JUMPER
0320	7106170	1	BLISTER PACK, SNAP-IN KEY SWITCH U

Electrical Schematic - Charging Circuit - Kawasaki FR730V

Note: Unless noted otherwise, use the standard torque specifications

Mfg. No: 5902056

80097605 MAIN WIRE HARNESS - KAWASAKI FR730V ENGINES

80097605B

(If internal schematic of the switch is not shown, the image of the switch represents the back view of the connector as it is connected to the switch.)

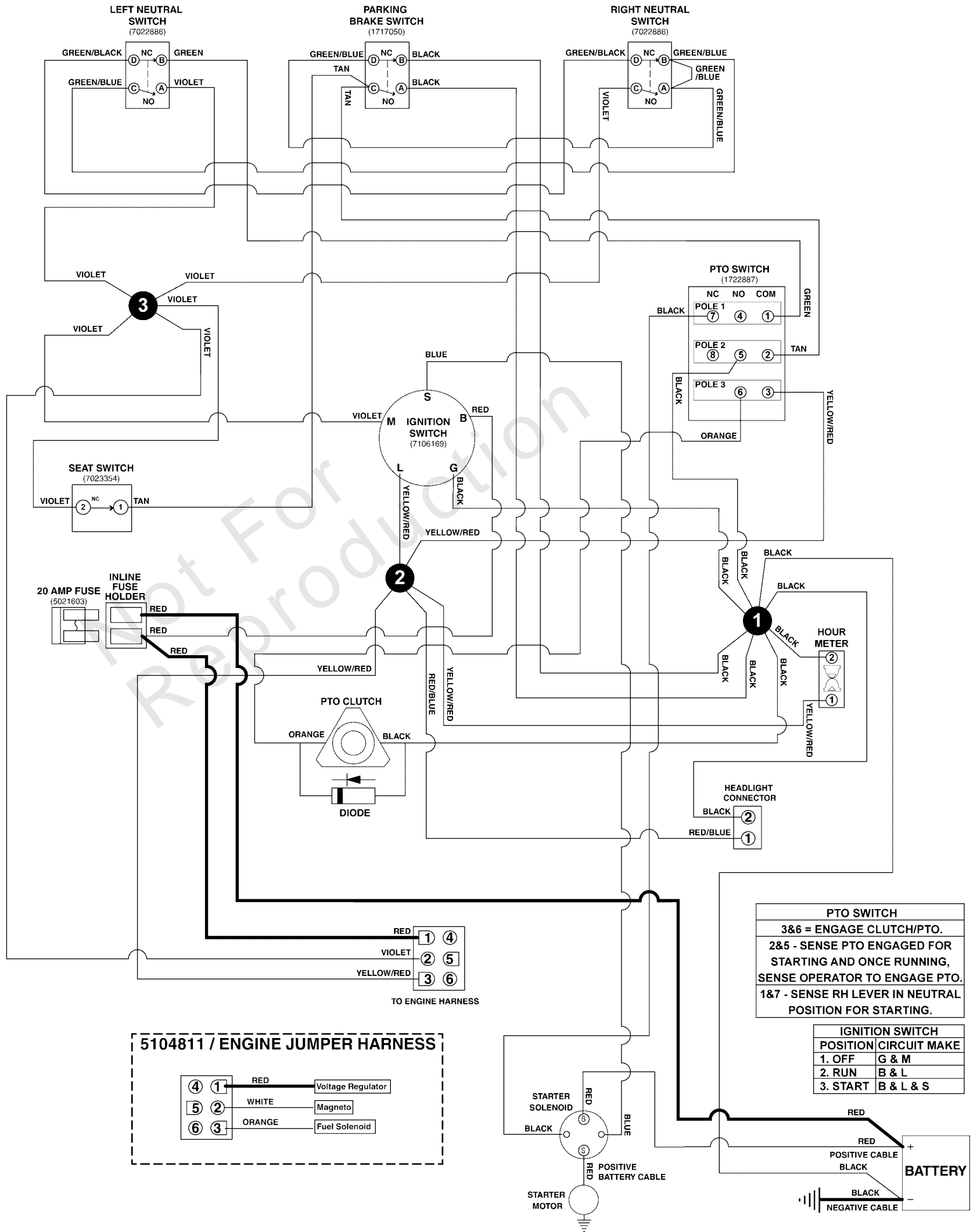

Electrical Schematic - Charging Circuit - Kawasaki FR730V

REF NO	PART NO	QTY	DESCRIPTION
80097605	80097605	1	HARNESS, WIRING, XT MAIN (ZT)
7022886	7022886	2	SWITCH, DP NO/NC SNAP-IN
1717050	1717050	1	SWITCH, PLUNGER, N.O./N.C.
1722887	1722887	1	SWITCH-PTO PUSH
7106169	7106169	1	SWITCH, IGNITION, DELTA, (3 POSITION)
7023354	7023354	1	SWITCH, SEAT
5021603	5021603	1	FUSE, ATO-20 (20 AMP)(SV)
5104811	5104811	1	WIRE HARNESS, JUMPER, KAWI

Not For Reproduction

Electrical Schematic - Cranking Circuit - Kawasaki FR730V

Note: Unless noted otherwise, use the standard torque specifications

Mfg. No: 5902056

80097605 MAIN WIRE HARNESS - KAWASAKI FR730V ENGINES

80097605B

(If internal schematic of the switch is not shown, the image of the switch represents the back view of the connector as it is connected to the switch.)

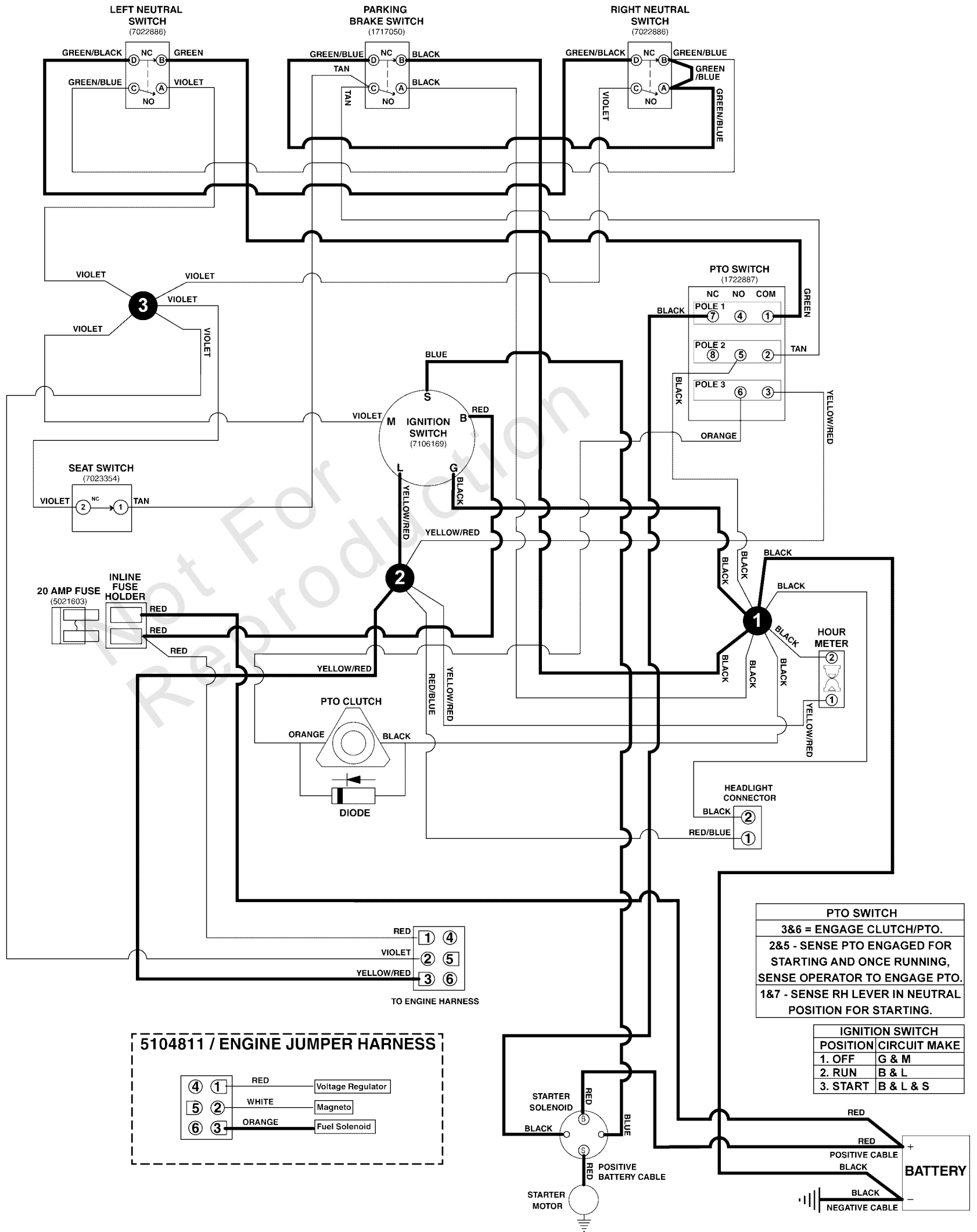

Electrical Schematic - Cranking Circuit - Kawasaki FR730V

REF NO	PART NO	QTY	DESCRIPTION
80097605	80097605	1	HARNESS, WIRING, XT MAIN (ZT)
7022886	7022886	2	SWITCH, DP NO/NC SNAP-IN
1717050	1717050	1	SWITCH, PLUNGER, N.O./N.C.
1722887	1722887	1	SWITCH-PTO PUSH
7106169	7106169	1	SWITCH, IGNITION, DELTA, (3 POSITION)
7023354	7023354	1	SWITCH, SEAT
5021603	5021603	1	FUSE, ATO-20 (20 AMP)(SV)
5104811	5104811	1	WIRE HARNESS, JUMPER, KAWI

Not For Reproduction

Electrical Schematic - Ignition Grounding Circuit/Op. Pres. - Kawasaki FR730V

Note: Unless noted otherwise, use the standard torque specifications

Mfg. No: 5902056

80097605 MAIN WIRE HARNESS - KAWASAKI FR730V ENGINES

80097605B

(If internal schematic of the switch is not shown, the image of the switch represents the back view of the connector as it is connected to the switch.)

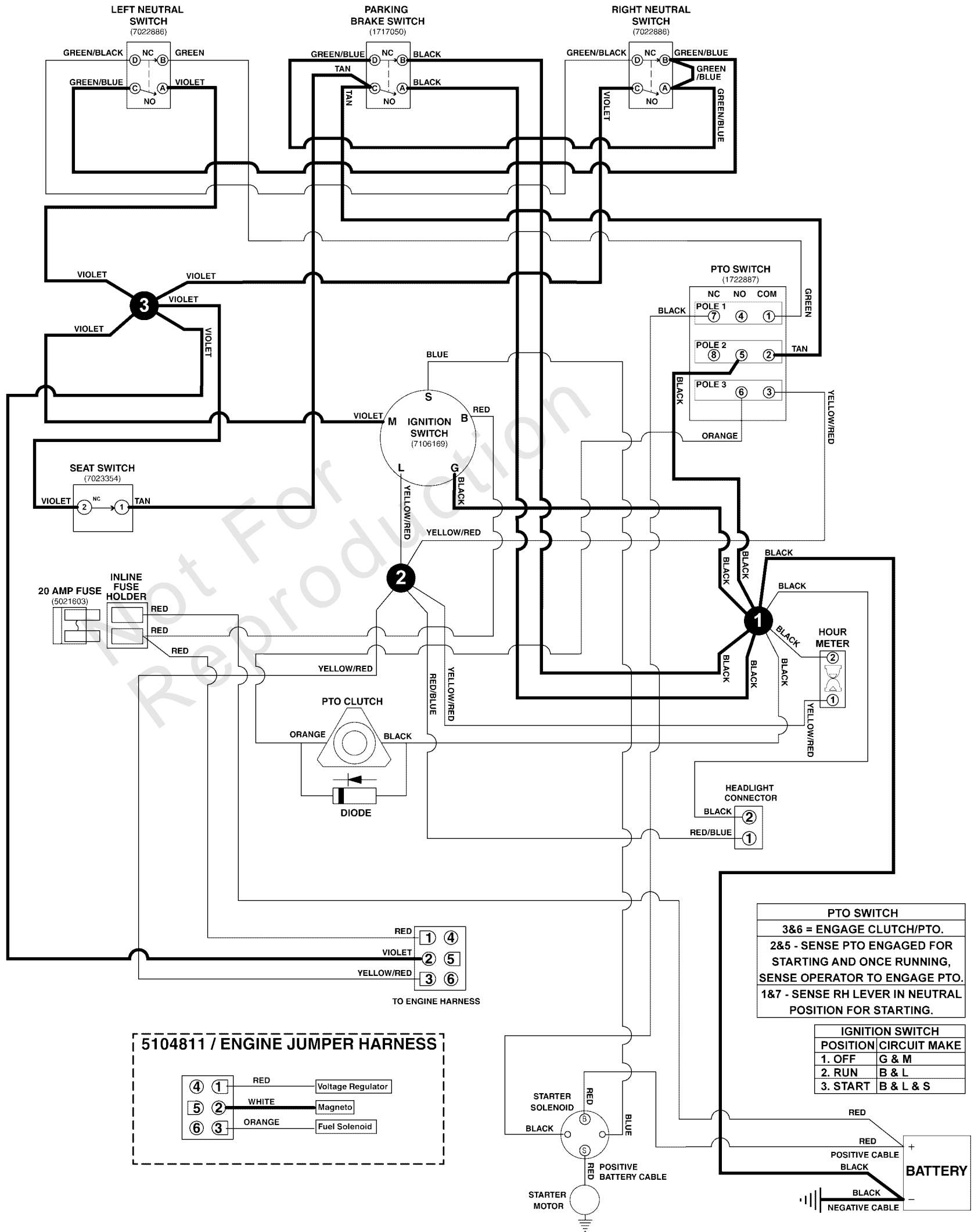

Electrical Schematic - Ignition Grounding Circuit/Op. Pres. - Kawasaki FR730V

REF NO	PART NO	QTY	DESCRIPTION
80097605	80097605	1	HARNESS, WIRING, XT MAIN (ZT)
7022886	7022886	2	SWITCH, DP NO/NC SNAP-IN
1717050	1717050	1	SWITCH, PLUNGER, N.O./N.C.
1722887	1722887	1	SWITCH-PTO PUSH
7106169	7106169	1	SWITCH, IGNITION, DELTA, (3 POSITION)
7023354	7023354	1	SWITCH, SEAT
5021603	5021603	1	FUSE, ATO-20 (20 AMP)(SV)
5104811	5104811	1	WIRE HARNESS, JUMPER, KAWI

Not For Reproduction

Electrical Schematic - PTO Clutch Circuit - Kawasaki FR730V

Note: Unless noted otherwise, use the standard torque specifications

Mfg. No: 5902056

80097605 MAIN WIRE HARNESS - KAWASAKI FR730V ENGINES

80097605B

(If internal schematic of the switch is not shown, the image of the switch represents the back view of the connector as it is connected to the switch.)

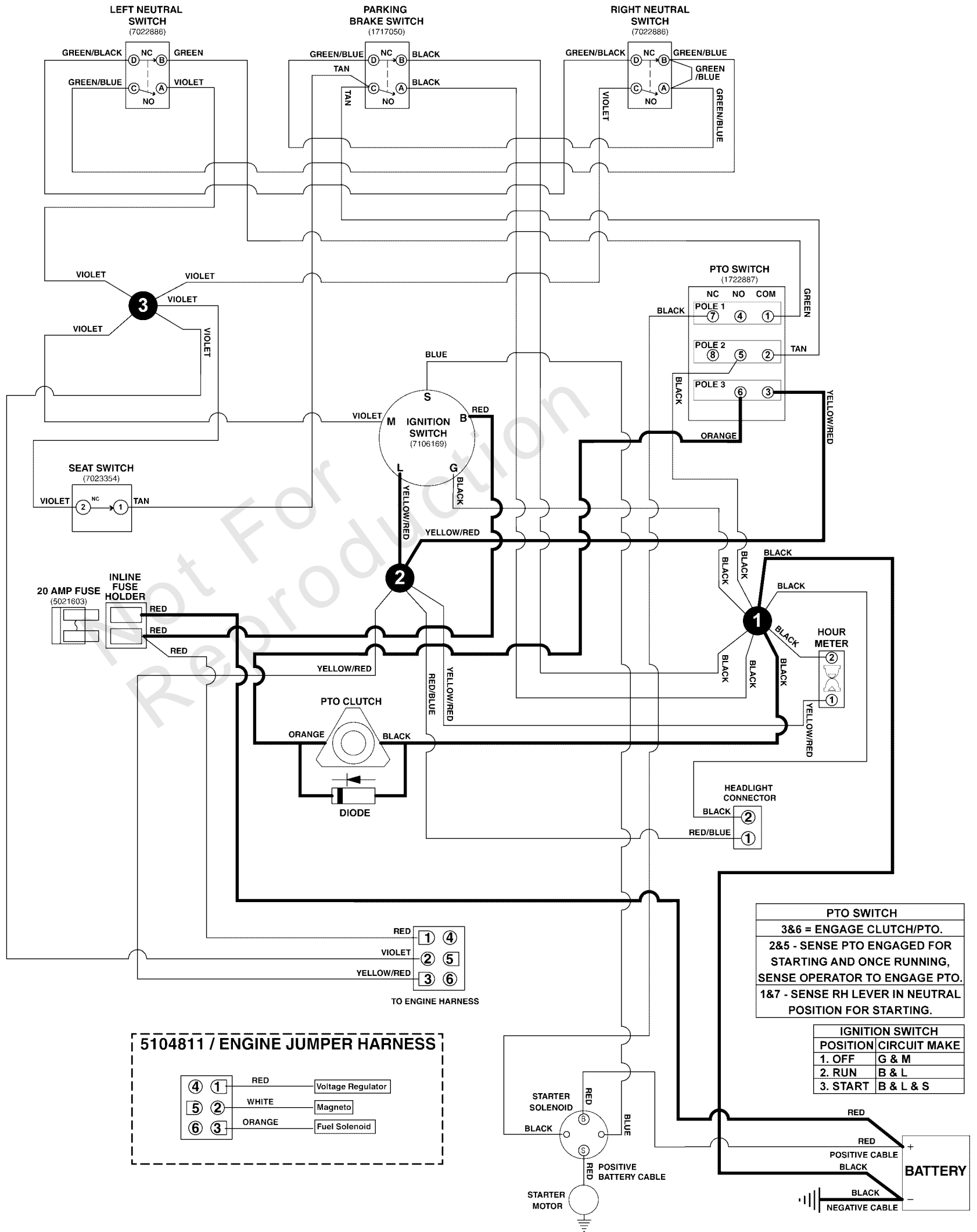

Electrical Schematic - PTO Clutch Circuit - Kawasaki FR730V

REF NO	PART NO	QTY	DESCRIPTION
80097605	80097605	1	HARNESS, WIRING, XT MAIN (ZT)
7022886	7022886	2	SWITCH, DP NO/NC SNAP-IN
1717050	1717050	1	SWITCH, PLUNGER, N.O./N.C.
1722887	1722887	1	SWITCH-PTO PUSH
7106169	7106169	1	SWITCH, IGNITION, DELTA, (3 POSITION)
7023354	7023354	1	SWITCH, SEAT
5021603	5021603	1	FUSE, ATO-20 (20 AMP)(SV)
5104811	5104811	1	WIRE HARNESS, JUMPER, KAWI

Not For Reproduction

Engine and PTO Group

REF NO	PART NO	QTY	DESCRIPTION
0005	-----	1	ENGINE, 24HP, KAWI, FR730V, 1-1/8 CRANK -(Engine Model: FR730V-AS25-R)
0010	80098036	1	PULLEY, CRANKSHAFT
0011	5022726	1	KEY 1/4 SQ X 1 1/2 LONG
0020	80093964	1	CLUTCH, WARNER, 125 FT-LB, 1.13" X 6.324
0025	5021030	1	TIE, SELF-LOCKING, 6"
0050	5102868	1	BOLT, CRANKSHAFT, 7/16-20 X 3-3/4, GD8
0060	80093428AA	1	BRKT, CLUTCH ANCHOR (BLACK)
0061	80093429	1	PAD, CLUTCH ANCHOR
0062	5044617	4	WASHER, .34 X 1.25 X 10 GA
0064	5025055X18	1	BOLT, 5/16-18 X 2-1/4 TFL, GD5 YZ
0065	5025127	1	NUT, 5/16-18 HEX SERRATED FLANGE (SMALL)
0080	5025640	4	BOLT, 3/8-16X1-1/4 SF, GD8, PHOS, SER HD
0110	1758352	1	MUFFLER, ZT (KAWI FR651/691/730)
0120	80096582AA	1	SHIELD, HEAT (BLACK)
0150	80004565	6	BOLT, 5/16-18X1.000, SHORT NECK CRRG, ZC/CL
0160	5025392	8	NUT, 5/16-18 HEX NYLOCK FLANGE NUT
0170	5050831X35	1	1/4" Fuel Line, 35" Long
0180	93807	2	CLAMP, Hose
0190	1759205	1	CONTROL, THROTTLE-THROTTLE ONLY (40.0LG)
0200	5100184	1	CABLE, CHOKE CONTROL, 43.5"
0205	80005209	1	WSHR, 3/8EXT TOOTH LOCK, TYPE A, ZINC/CLR
0206	80004865	1	NUT, 3/8-24, HEX, GR 5, ZINC/CLEAR
0210	1739312	1	KNOB, Throttle
0220	36917	1	SCREW, Pan Head Machine - No. 8-32 x 3/8"
0230	80004411	1	NUT #8-32 HEX ZINC/CLEAR
0240	1726498	1	HOSE-OIL DRAIN .375ID 16.5L
0250	5022234	1	ADAPTER, Oil Drain
0280	80095386AA	1	PANEL, CONTROL (BLACK)
0290	5022665	3	BODY CLIP, 1/4-20 X 1/2" DEEP
0310	7090999	5	SCREW, 1/4-20 x 5/8" Pan Head Self-Tap (Torx)
0320	80005611	1	SCREW, Hex Head, M8 X 20
0330	80003618	1	WSHR 5/16EXT TOOTH LOCK TYPE A ZINC/CLR
0370	5025585	2	BELLEVILLE WASHER, 1.1875 X .442 X .098
0380	5104811	1	WIRE HARNESS, JUMPER, KAWI

Footnotes:

Note:* See your local Kawasaki distributor for parts & service.

Evap Group

Note: Unless noted otherwise, use the standard torque specifications

Mfg. No: 5902056

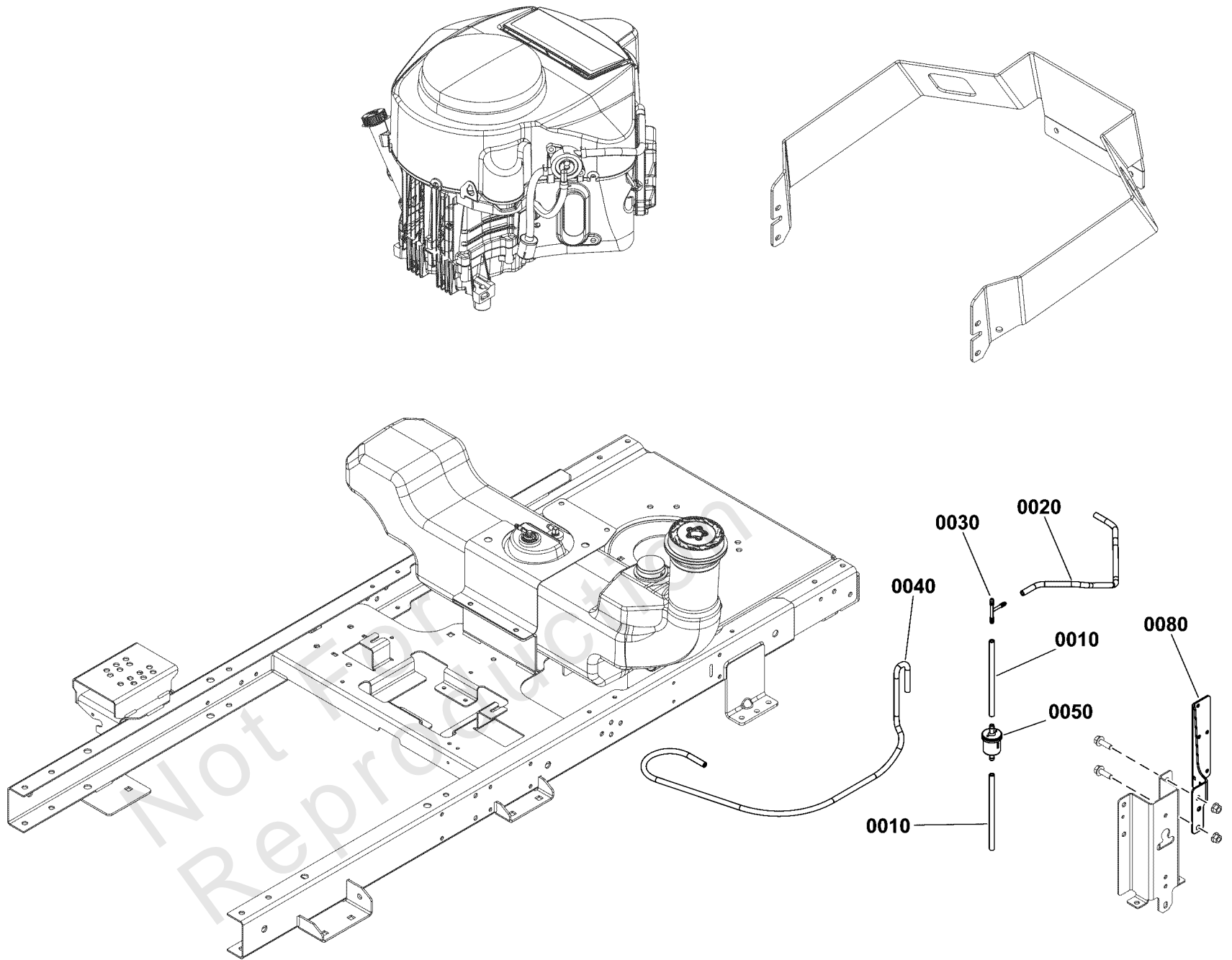

Evap Group

REF NO	PART NO	QTY	DESCRIPTION
0010	7700552X6	2	HOSE, Vapor, 5 MM ID, 6.00 LG
0020	7700552X19	1	HOSE, VAPOR, 5MM ID, 19.00 LG
0030	5103062	1	FITTING, 3/16" TEE, BARB TYPE, HDPE
0040	7700552X43	1	HOSE, VAPOR, 5MM ID, 43.00 LG
0050	80025019	1	FILTER, FUEL
0070	5021030	6	TIE, SELF-LOCKING, 6" -(Not Illustrated)
0080	1760552A	1	BRKT, VENT HOSE MNT - KAW TWIN (BLK)

Not For Reproduction

Frame, Pivoting Front Axle, Floor Pan, and Bumper Group

Note: Unless noted otherwise, use the standard torque specifications

Mfg. No: 5902056

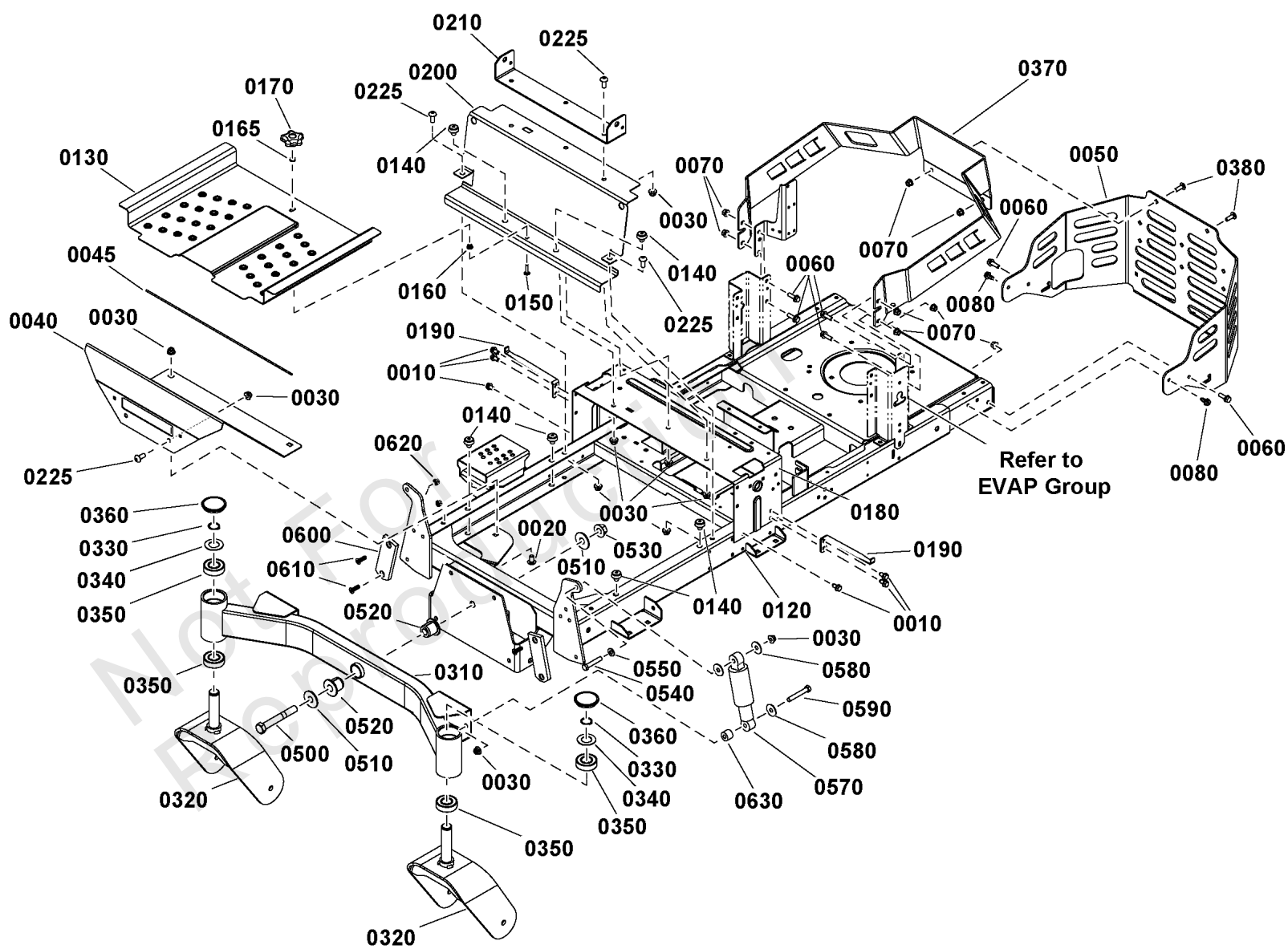

Frame, Pivoting Front Axle, Floor Pan, and Bumper Group

REF NO	PART NO	QTY	DESCRIPTION
0010	80005404	6	SCREW,5/16-18X0.625,WSHR,THD-ROLL,ZC/CL
0020	80003585	2	BOLT,3/8-16X.75,GR5,CARRIAGE,ZC/CL
0030	5025394	13	NUT, 3/8 - 16 HEX NYLOCK FLANGE
0040	80096035B	1	FOOT REST, XT (FER RED)
0045	5101011	1	SAFETY WALK, 8.00 X 15.00
0050	80104055B	1	BUMPER, REAR, XT (FER RED)
0060	-----	6	BOLT,5/16-18X1.000,SRRTD FLANGE,GR5,ZC/C
0070	5025392	8	NUT, 5/16-18 HEX NYLOCK FLANGE NUT
0080	-----	2	SCREW, 5/16-18 x 3/4" Hex Washer Head Self-Tap, Black
0120	-----	1	WELDMENT, ZT XT FRAME-FULL SUSP(FER R) -(Not a serviceable part)
0130	1757813B	1	PAN, BOTTOM FOOT - RED
0140	197546	6	MNT, VBRTN, RBBR
0150	7090496	1	BOLT, 1/4-20 x 1" Grade 2 Short Neck Carriage
0160	5025126	1	NUT, 1/4-20 HEX SERR. FLANGE
0165	80003547	1	NUT 1/4-20 CNTR FLNG ZINC/CLEAR
0170	80008144	1	KNOB, HNDL, 5 PRONG
0180	80096436B	1	BRKT, CONTROL (FER RED)
0190	1758240AFS	2	SUPPORT, FENDER
0200	1757796B	1	BRKT, BRAND PLATE - RED
0210	5416789B	1	PLATE, SEAT PLATE PIVOT
0225	80087701	7	SCREW, 3/8-16 X .88 PAN HD TORX
0310	80096787B	1	WELDMENT, PIVOTING AXLE - 61 (FER RED)
0320	84007952	2	YOKE, Caster
0330	80005606	2	RETAINER,1.000,EXT RING,ZINC/CLEAR
0340	80004282	2	WASHER,1.017IDX1.812ODX0.6THK,FLAT,ZC/CL
0350	1758354	4	BEARING, 25 MM ID
0360	5105524	2	CAP, Caster
0370	80096896B	1	BRACKET, Fascia, Rear (FER RED)
0380	80004565	2	BOLT,5/16-18X1.000,SHORT NECK CRRG,ZC/CL
0500	80012496	1	BOLT, HEX HD 5/8-11 X 4.50 G5
0510	1960035	2	WASHER, 0.64 I.D. x 1.75 O.D. x .11 Thick, Black
0520	1759234	2	BUSHING, FLANGED - AXLE
0530	80026832	1	NUT-HEX FLANGE 5/18-11 TWO WAY LOCK ZC/CL
0540	80003522	2	HHCS, 3/8-16 X 2.00, GR5, ZINC/CLEAR
0550	5025156	2	WASHER, 3/8 SAE
0570	1755279	2	SHOCK ABSORBER, 8" LENGTH
0580	5025165	6	WASHER, 3/8" Fender
0590	5025013X20	2	BOLT, 3/8-16 X 2-1/2" GD5 CZ
0600	1759391	2	PAD, FRICTION - 1.75 X 5.03
0610	5025594	4	SCREW, 5/16-18 X 1, PHILLIPS HD, BZ
0620	5025057	4	NUT, Hex, Nylon Locking, 5/16-18
0630	1667812	2	SPACER-0.390ID 0.90 OD 0.70LG P'MTL

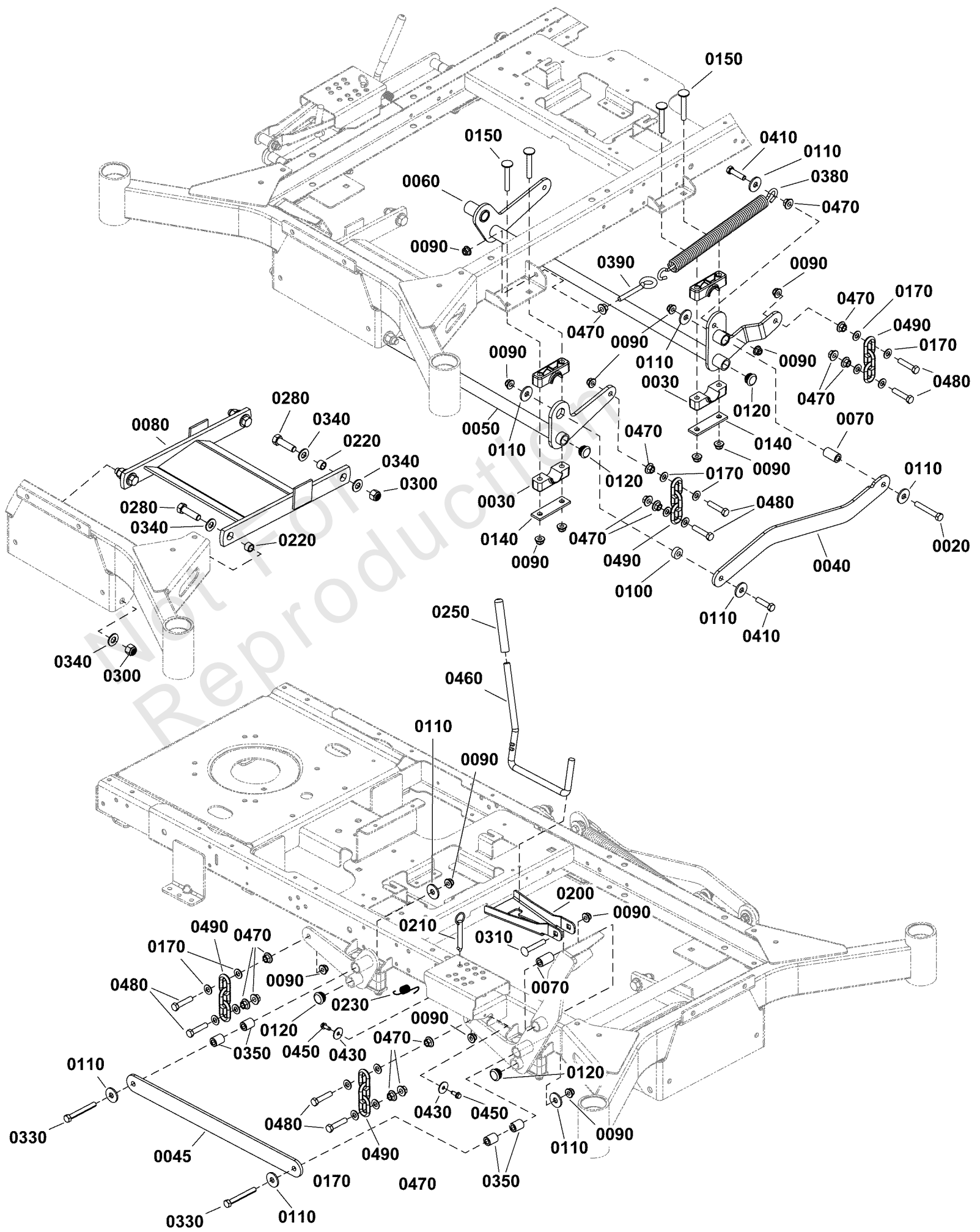

Lift Group

REF NO	PART NO	QTY	DESCRIPTION
0020	5025013X20	1	BOLT, 3/8-16 X 2-1/2" GD5 CZ
0030	5100634	8	PIVOT BLOCK, PLASTIC
0040	80094608AA	1	LINKAGE, LIST ASSIST - LH, BLK
0045	80094609AA	1	LINKAGE, LIFT ASSIST - RH, BLK
0050	80092052AA	1	WELDMENT, MOWER LIFT - FOOTASSIST, BLK
0060	80091744AA	1	WELDMENT, LIFT SHAFT ASSY REAR, BLK
0070	1756612	2	BUSHING, DIFF. LOCK
0080	80092234AA	1	WELD, PULLER BAR, XT-HOZ - BLK
0090	5025394	19	NUT, 3/8 - 16 HEX NYLOCK FLANGE
0100	1667811	1	SPACER-0.390ID 0.90 OD 0.34 LG P'MTL YEL
0110	80022437	9	WASHER-0.375(0.44IDX1.250DX.12THK) ZC/CL
0120	-----	4	PLUG
0140	5403925AA	4	PLATE, PIVOT BLOCK SUPPORT - BLK
0150	1960615	8	CARRIAGE BOLT, 3/8-16 x 2-1/2
0170	5025156	16	WASHER, 3/8 SAE
0200	1758284AA	1	BRACKET, MOWER HOC STOP (BLACK)
0210	5103021	1	HITCH PIN, 3/8 X 2-1/2, COTTERLESS, CZ
0220	5020870	4	INSERT, Bearing
0230	1758283	1	SPRING, EXTENSION
0250	5021880	1	GRIP, FOAM, .475 X 4.35 X .095
0280	5025018X14	4	BOLT, 1/2-20 X 1-3/4" GD8 CZ
0300	5025098	4	NUT, Hex, Nylon Lock, 1/2-20
0310	7900009	1	RHSSNB, 3/8-16 X 2-1/4, GR5
0330	5025013X24	2	BOLT, 3/8-16 X 3" GD5 CZ
0340	5025158	8	WASHER, 1/2 SAE
0350	1733068	4	SPACER
0380	5023355	1	SPRING-EXT, 1.00 ODX13.25LGX.177WR, BLK
0390	5025429	1	EYEBOLT, 3/8-16 X 4, 2.13THRD, .75EYE, C
0410	80004479	2	* CAPSCREW, Hex Head, 3/8-16 X 1-1/2, GR5
0430	5025288	2	WASHER, 1/4" Fender
0450	80004190	2	SCREW, Hex Washer Head, Thread Roll, 1/4-20 x 5/8
0460	5105717	1	ROD, MOWER TRANSPORT RELEASE
0470	5025128	14	NUT, 3/8-16 Hex Large Serrated Flange
0480	5025013X14	8	BOLT, 3/8-16 X 1-3/4" GD5 CZ
0490	5050878X3	4	CHAIN, 5/16" GD30, 3 LINKS

Parking Brake Group

Note: Unless noted otherwise, use the standard torque specifications

Mfg. No: 5902056

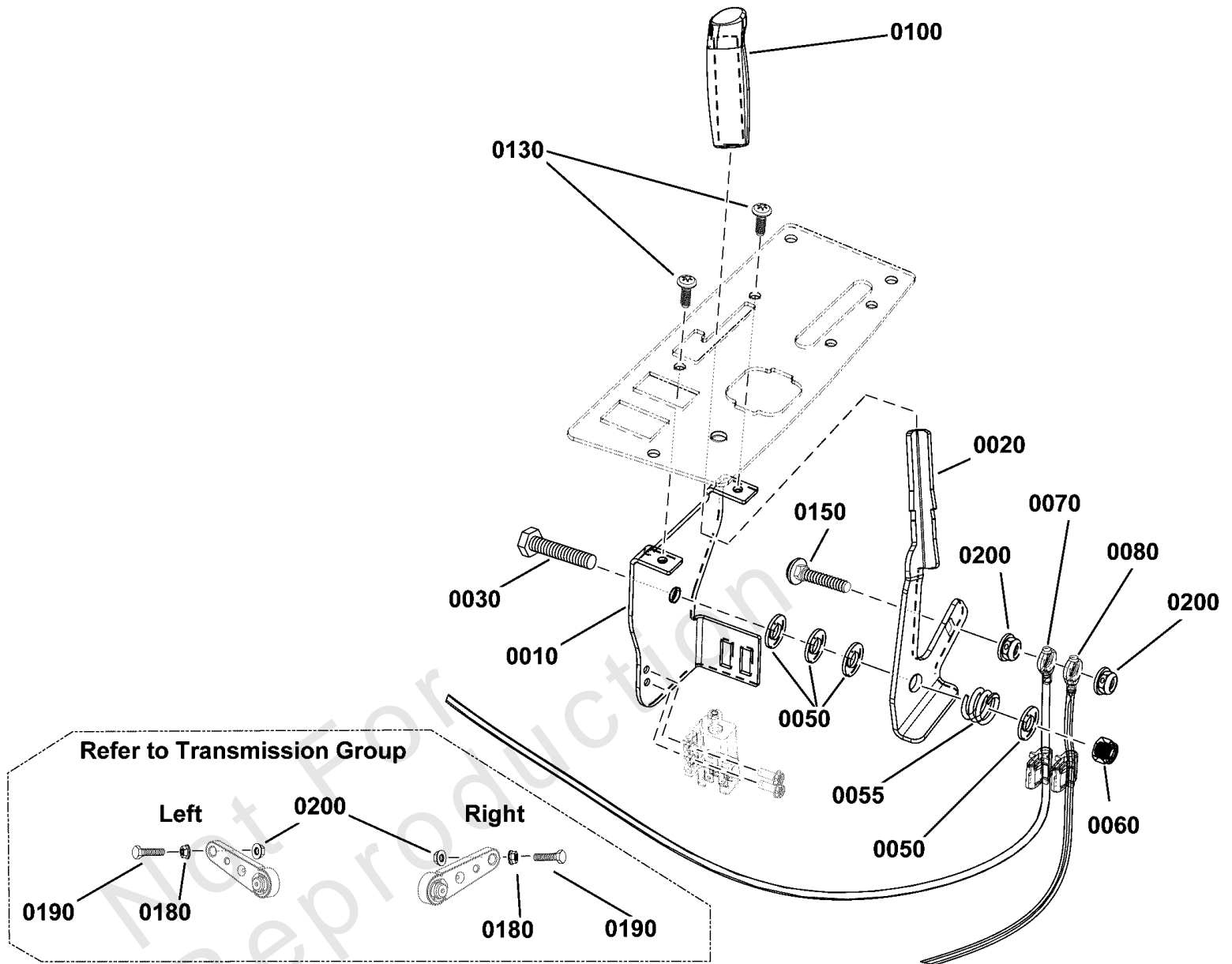

Parking Brake Group

REF NO	PART NO	QTY	DESCRIPTION
0010	80094114AA	1	BRACKET, LEVER, PARK BRAKE (BLK)
0020	80097637AA	1	LEVER, XT PARKING BRAKE (BLK)
0030	80003522	1	HHCS, 3/8-16 X 2.00, GR5, ZINC/CLEAR
0050	80003621	4	WSHR,.406X.875X.083FLT,TYPE A,ZINC/CLEAR
0055	7028036	1	SPRING, Friction Pack
0060	5025096	1	NUT, 3/8-16 HEX NYLON LOCK
0070	80094463	1	CABLE, PARKING BRAKE - LH
0080	80094465	1	CABLE, PARKING BRAKE - RH
0100	1761916	1	GRIP, LATCH
0130	7090999	2	SCREW, 1/4-20 x 5/8" Pan Head Self-Tap (Torx)
0140	-----	3	TIE, 7, Self Lock -(Not Illustrated)
0150	-----	1	BOLT, 5/16-18 x 1-3/4" Round Head Short Square Neck
0180	5025127	2	NUT, 5/16-18 HEX SERRATED FLANGE (SMALL)
0190	5025011X12	2	BOLT, 5/16-18 X 1-1/2" GD5 YZ
0200	5025392	4	NUT, 5/16-18 HEX NYLOCK FLANGE NUT

Rear Suspension Group

Note: Unless noted otherwise, use the standard torque specifications

Mfg. No: 5902056

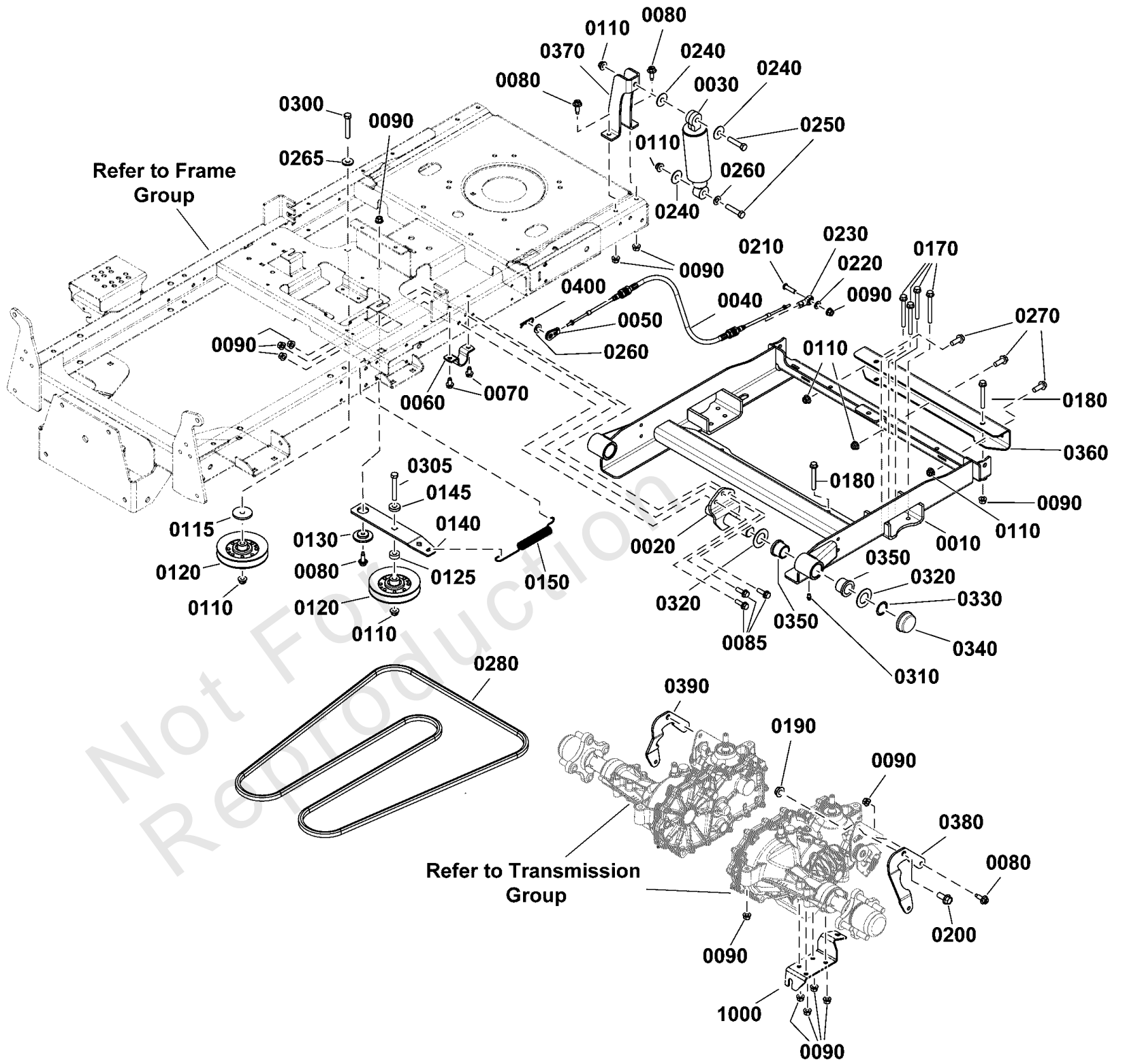

Rear Suspension Group

REF NO	PART NO	QTY	DESCRIPTION
0010	80092995B	1	WELDMENT, TRANSMISSION CARRIER (FER RED)
0020	1758716B	2	WELDMENT, REAR SWING ARM PIVOT - RED
0030	1758705	2	SHOCK ABSORBER, 10.5" LENGTH, RATE 160LB -(Refer to Note:*)
0040	1759206YP	2	CABLE, Push/Pull
0050	1759413	2	END, CABLE
0060	1720147	2	STRAP 1.00 DIA. SHAFT
0070	80005404	4	SCREW,5/16-18X0.625,WSHR,THD-ROLL,ZC/CL
0080	80020384	7	SCREW-HEX WZ LOCK FLNG 5/16-18 X1.00 DOG
0085	-----	6	BOLT,5/16-18X1.000,SRRTD FLANGE,GR5,ZC/C
0090	5025392	27	NUT, 5/16-18 HEX NYLOCK FLANGE NUT
0110	5025394	9	NUT, 3/8 - 16 HEX NYLOCK FLANGE
0115	1757738	1	SPACER IDLER 42
0120	1759212	2	PULLEY, V-IDLER, 4.50"
0125	1667811	1	SPACER-0.390ID 0.90 OD 0.34 LG P'MTL YEL
0130	1727935	1	SPACER, Pivot 0.330ID 1.76OD .37TH Powdered Metal
0140	1761878AA	1	ARM, TRANSMISSION DRIVE IDLER (BLACK)
0145	5044960	1	SPACER, .39 X 1.00 X .25, PM, CZ
0150	1758045	1	SPRING, EXTENSION
0170	80008909	8	SCREW, HEX WASHER HD-5/16-18X3.00
0180	80018048	4	SCREW, HEX WASHER HD-5/16-18X2.50
0190	1930650	2	NUT-HEX FLANGE 7/16-14 TWO WAY LK GA BLK
0200	1960043	2	SCREW-HEX WZ LOCK FLNG7/16-14X1.000 BLK
0210	80003716	2	SCREW BUTTON HEAD CAP ZINC PHOS&OIL
0220	5025155	4	WASHER, 5/16" SAE
0230	5101801	2	ROD END, FEMALE, 10-32 W 5/16" BORE
0240	5025165	6	WASHER, 3/8" Fender
0250	5025013X14	4	BOLT, 3/8-16 X 1-3/4" GD5 CZ
0260	5025156	4	WASHER, 3/8 SAE
0265	80003616	1	WSHR,.406X1.0X.134,FLT,TYPE A,ZINC/CLEAR
0270	5025390X8	3	BOLT, 3/8-16 X 1, FLANGE, GD 5, CZ
0280	80103769	1	V-BELT, HAA, 111.97
0300	5025013X18	1	BOLT, 3/8-16 X 2-1/4" GD5 CZ
0305	5025013X20	1	BOLT, 3/8-16 X 2-1/2" GD5 CZ
0310	1704314	2	LUBE FITTING, 1/4 Drive , Check Ball
0320	80004282	4	WASHER,1.017IDX1.812ODX0.6THK,FLAT,ZC/CL
0330	80004283	2	PUSH NUT, FLAT 1.00 SHAFT, PHOS/OIL
0340	721318	2	CAP, Hub
0350	1758717	4	BUSHING, FLANGE, 1.00 X 1.00 LG, PLASTIC
0360	1759163B	1	BRKT, REAR TRANS SUPPORT - RED
0370	1758778B	2	BRKT, REAR COIL-OVER MNT - RED
0380	1759021A	1	PLATE, TRANS CONTROL ARM LH (BLACK)
0390	1759022A	1	PLATE, TRANS CONTROL ARM RH (BLACK)
0400	-----	2	PIN, 3/32 X 1.600, HAIR, ZINC/CLEAR
1000	-----	1	Refer to: Transmission Group - Suspension

Footnotes:

Note:* Spring Rate 160lbs / 59.7kg +/- 10lbs / 3.7kg

Seat Group

REF NO	PART NO	QTY	DESCRIPTION
0020	1752802	2	BOLT, Shoulder, 5/16-18 x 1
0030	1760194B	1	SLIDE, SEAT (FER RED)
0040	80004473	2	BOLT,5/16-18X1.000,ROUND HD CRRG,ZC/CL
0060	1717051	2	SPRING, Compression
0070	80093738	1	SEAT, NEC1110, SNAPPER
0070-10	80104376	1	COVER, CUSHION, SNP
0070-20	80104374	1	COVER, BACK, SNP
0080	5025392	10	NUT, 5/16-18 HEX NYLOCK FLANGE NUT
0090	80003616	2	WSHR,.406X1.0X.134,FLT,TYPE A,ZINC/CLEAR
0210	80014989	2	CABLE TIE, 8, PUSH-MOUNT (.250 HOLE)
0220	5103767	2	SPACER, .33 X .63 X .36, PM, CZ
0230	5025011X8	2	BOLT, 5/16-18 X 1" GRD5 YZ
0240	80003621	2	WSHR,.406X.875X.083FLT,TYPE A,ZINC/CLEAR

Not For Reproduction

Transmission Group - Suspension

Note: Unless noted otherwise, use the standard torque specifications

Mfg. No: 5902056

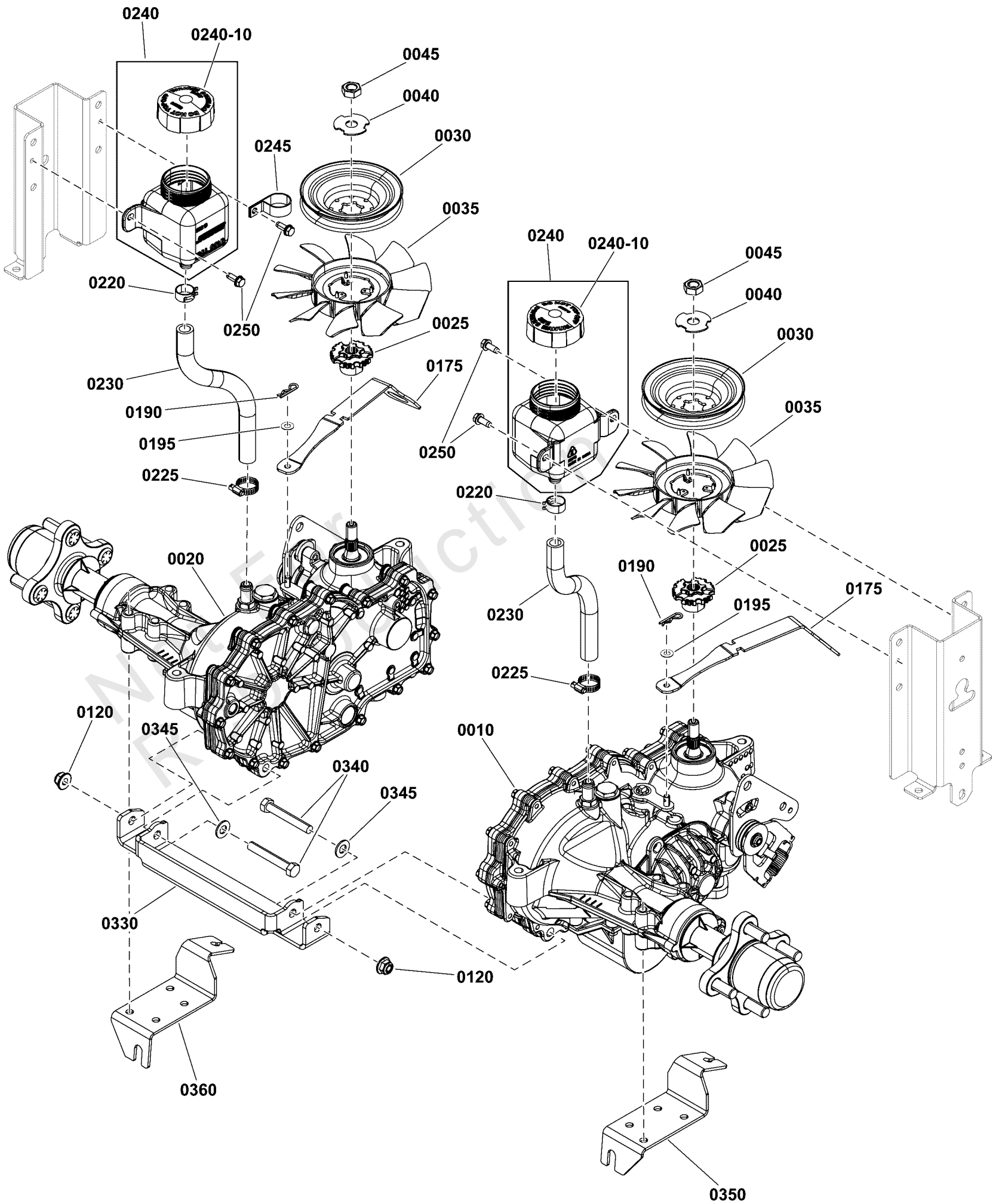

Transmission Group - Suspension

REF NO	PART NO	QTY	DESCRIPTION
0010	80093968	1	TRANSAXLE, ZT3100, ZL-HPHH-UL7B-2XLX -(Left side)
0020	80093967	1	TRANSAXLE, ZT3100, ZL-LPHH-UL7C-3XLX -(Right side)
0025	5107809	2	SPACER, Transmission, 17 Tooth Spline (HG-54759)
0030	1759447	2	PULLEY, TRANSMISSION INPUT (4.50")
0035	84007455	2	FAN
0040	5102914	2	WASHER, ZT5400, SLOTTED
0045	5102916	2	NUT, ZT5400 -(Torque to 45 - 55 ft-lbs (61 - 75,6 Nm))
0120	5025394	2	NUT, 3/8 - 16 HEX NYLOCK FLANGE
0175	1759276A	2	VALVE, TOW (2800 SUSP) (BLACK)
0190	80003663	2	HAIRPIN.080 WIRE 1.19LG.25DIA,ZINC/CLEAR
0195	5025154	2	WASHER, 1/4 SAE
0220	5025474	2	CLAMP, HOSE, .75 FREE DIA.
0225	5021392	2	CLAMP, #6 HOSE, STAINLESS
0230	5050857X10	2	HOSE, 1/2" PUSH-ON, 10.00"
0240	5100473	2	RESERVOIR, HYDRO OIL, 350 ML -(Includes item # 0240-10.)
0240-10	5100778X1	2	RESERVIOR CAP
0245	5021500	1	CLAMP, VINYL INSULATED, 1.00 -(This clamp is mounted on the left side of the unit for Briggs & Stratton powered models.)
0250	80004190	4	SCREW, Hex Washer Head, Thread Roll, 1/4-20 x 5/8
0330	1759172AA	1	NLA -BRKT,FRONT TRANS SUPPORT(2800)(BLK)
0340	5025013X20	2	BOLT, 3/8-16 X 2-1/2" GD5 CZ
0345	5025156	2	WASHER, 3/8 SAE
0350	80093636AA	1	BRKT, TRANSMISSION CABLES - LH (BLK)
0360	80093959AA	1	BRKT, TRANSMISSION CABLES - RH (BLK)

Wheel & Tire Group

Note: Unless noted otherwise, use the standard torque specifications

Mfg. No: 5902056

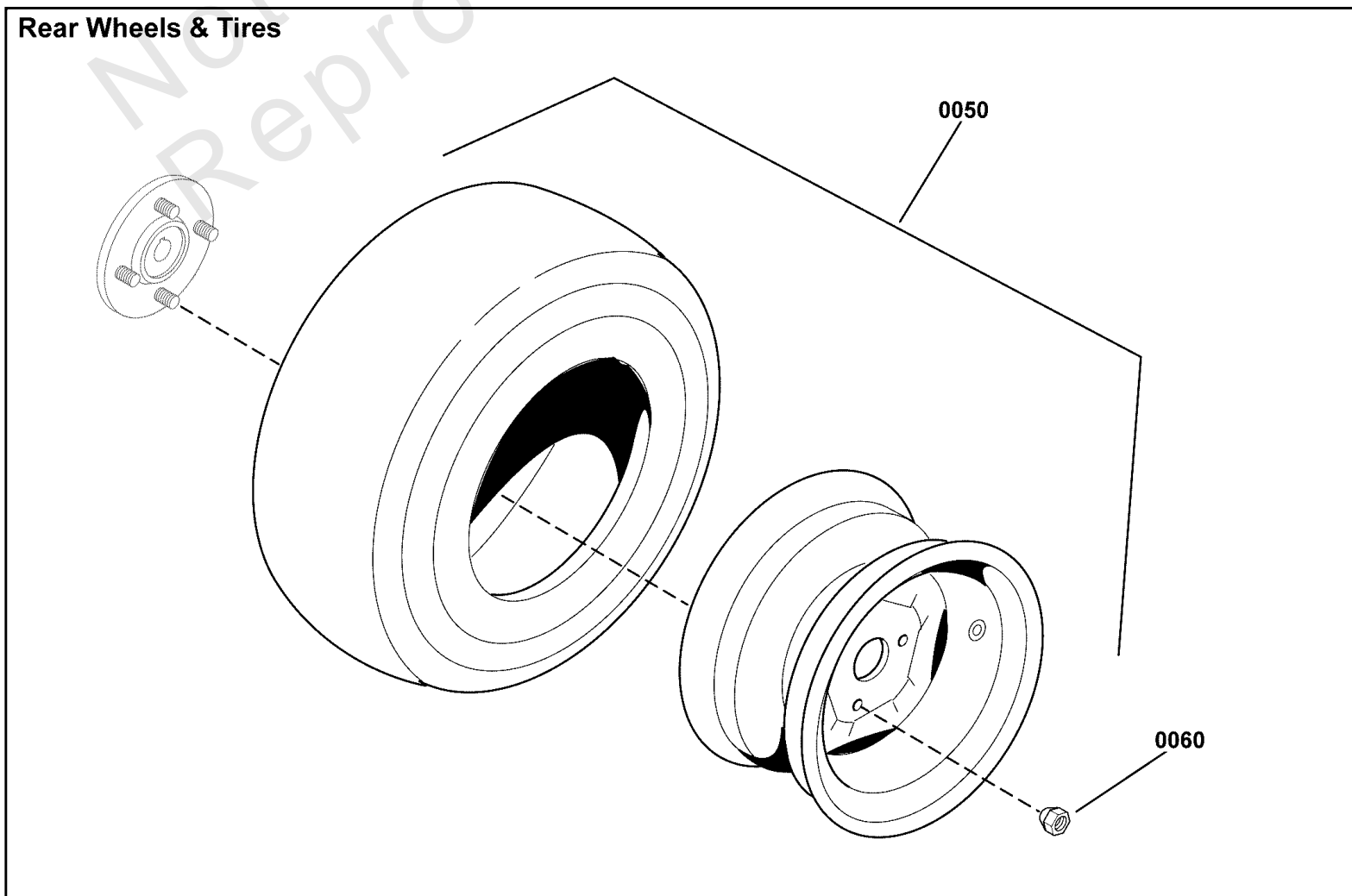
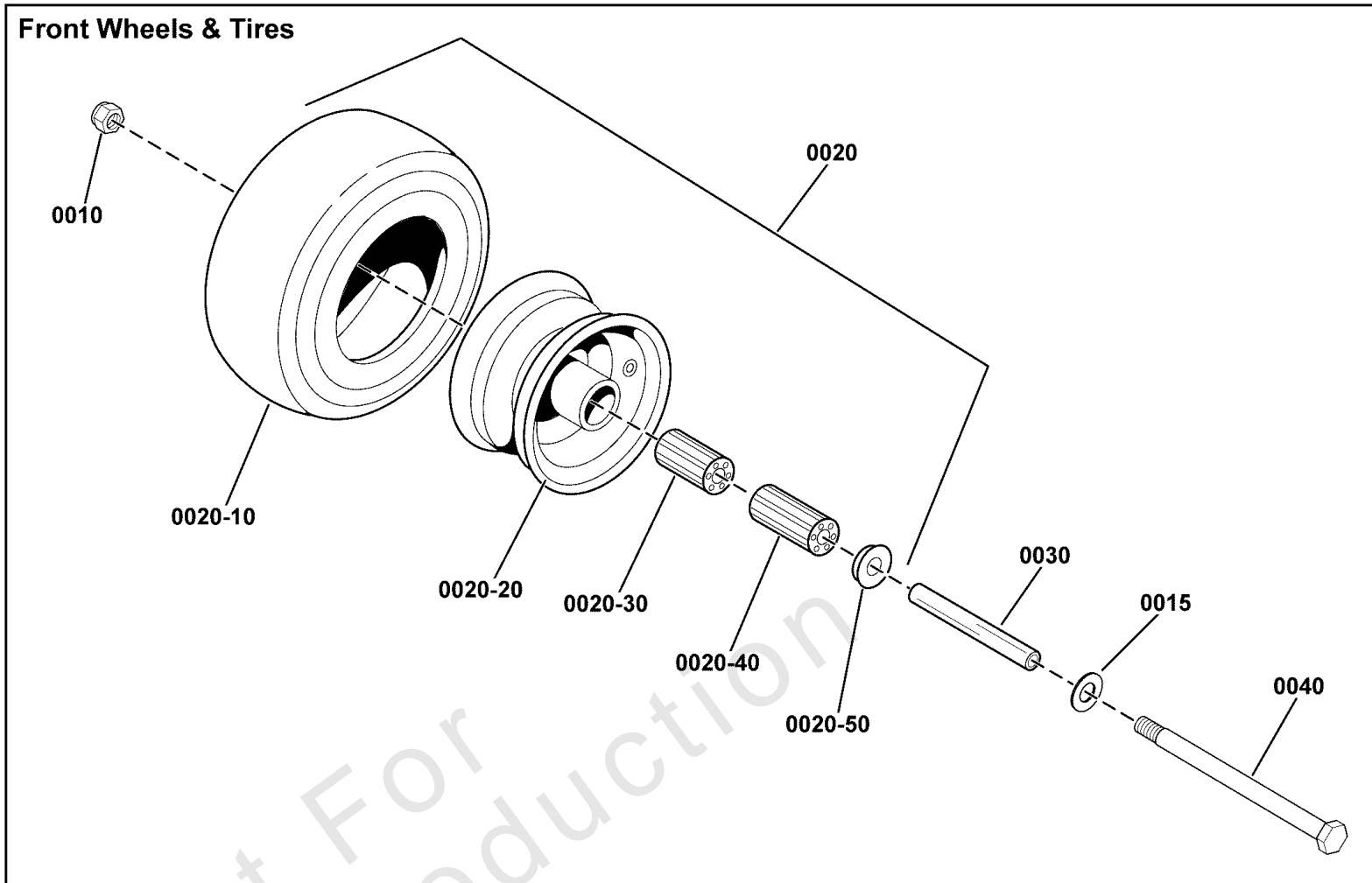

Wheel & Tire Group

REF NO	PART NO	QTY	DESCRIPTION
0010	5025396	2	NUT, Hex Flange, Nylock, 1/2-13
0015	5025158	2	WASHER, 1/2 SAE
0020	5109055FS	2	TIRE ASSEMBLY
0020-10	5022577	2	TIRE, RUBBER ONLY
0020-20	-----	2	WHEEL RIM
0020-30	84008029	2	BEARING
0020-40	5021182	2	BEARING, ROLLER 3/4" ID X 3.25" (ONE PER TIRE)(SV)
0020-50	5021043	2	RETAINER, BEARING (TWO PER TIRE)(SV)
0030	5106587	2	CASTER AXLE SHAFT, .51"ID X .75"OD X7.16
0040	5025017X72	2	BOLT, 1/2-13 X 9" GD5 YZ
0050	80094605	2	WHEEL AND TIRE ASSY, 22X11-10 (BLACK)
0060	5020601	8	NUT, 1/2-20, FOR WHEEL BOLT SILVER

Not For Reproduction

Hardware Identification & Torque Specifications

Torque Specification Chart								
FOR STANDARD METRIC MACHINE HARDWARE (Tolerance ± 20%)								
Property Class	5.6		8.8		10.9		12.9	
	Class 5.6		Class 8.8		Class 10.9		Class 12.9	
Size Of Hardware	in/lbs	Nm.	in/lbs	Nm.	in/lbs	Nm.	in/lbs	Nm.
	ft/lbs		ft/lbs		ft/lbs		ft/lbs	
M3	5.88	.56	13.44	1.28	19.2	1.80	22.92	2.15
M4	13.44	1.28	30.72	2.90	43.44	4.10	52.56	4.95
M5	26.4	2.50	60.96	5.75	5.97	8.10	7.15	9.7
M6	44.64	4.3	7.3	9.9	10.3	14	12.1	16.5
M7	5.2	7.1	12.1	16.5	16.9	23	19.9	27
M8	7.7	10.5	17.7	24	25	34	29	40
M10	15	21	35	48	50	67	59	81
M12	26	36	61	83	86.2	117	103	140
M14	42	58	101	132	136	185	162	220
M16	64	88	147	200	210	285	250	340
M18	89	121	202	275	287	390	346	470
M20	126	171	290	390	405	550	486	660
M22	169	230	390	530	559	745	656	890
M24	217	295	497	375	708	960	840	1140
M27	320	435	733	995	1032	1400	1239	1680
M30	435	590	995	1350	1401	1900	1681	2280
M33	590	800	1349	1830	1902	2580	2278	3090
M36	759	1030	1740	2360	2441	3310	2935	3980
M39	988	1340	2249	3050	3163	4290	3798	5150

Torque Specification Chart						
FOR STANDARD MACHINE HARDWARE (Tolerance ± 20%)						
Hardware Grade	No Marks		SAE Grade 5		SAE Grade 8	
	SAE Grade 2		SAE Grade 5		SAE Grade 8	
Size Of Hardware	in/lbs	Nm.	in/lbs	Nm.	in/lbs	Nm.
	ft/lbs		ft/lbs		ft/lbs	
8-32	19	2.1	30	3.4	41	4.6
8-36	20	2.3	31	3.5	43	4.9
10-24	27	3.1	43	4.9	60	6.8
10-32	31	3.5	49	5.5	68	7.7
1/4-20	66	7.6	8	10.9	12	16.3
1/4-28	76	8.6	10	13.6	14	19.0
5/16-18	11	15.0	17	23.1	25	34.0
5/16-24	12	16.3	19	25.8	29	34.0
3/8-16	20	27.2	30	40.8	45	61.2
3/8-24	23	31.3	35	47.6	50	68.0
7/16-14	30	40.8	50	68.0	70	95.2
7/16-20	35	47.6	55	74.8	80	108.8
1/2-13	50	68.0	75	102.0	110	149.6
1/2-20	55	74.8	90	122.4	120	163.2
9/16-12	65	88.4	110	149.6	150	204.0
9/16-18	75	102.0	120	163.2	170	231.2
5/8-11	90	122.4	150	204.0	220	299.2
5/8-18	100	136	180	244.8	240	326.4
3/4-10	160	217.6	260	353.6	386	525.0
3/4-16	180	244.8	300	408.0	420	571.2
7/8-9	140	190.4	400	544.0	600	816.0
7/8-14	155	210.8	440	598.4	660	897.6
1-8	220	299.2	580	788.8	900	1,244.0
1-12	240	326.4	640	870.4	1,000	1,360.0

The guides and ruler furnished below are designed to help you select the appropriate hardware.



Nut, M8

Thread Diameter (mm)

Inside Diameter (in) Threads per inch

Nut, 1/2-16

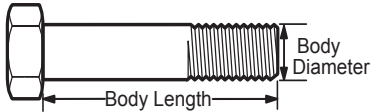

Screw, M8- 1.25 x 25

Thread Diameter (mm) Distance between threads (mm) Body Length (mm)

Body Diameter Threads per inch Body Length (in)

Screw, 1/2- 16 x 2



Standard Hardware Sizing

When a washer or nut is identified as 1/2" (M8), this is the *Nominal size*, meaning the *inside diameter* is 1/2 inch (8mm metric thread diameter); if a second number is present it represents the *threads per inch* (distance between threads).

When bolt or capscrew is identified as 1/2 - 16 x 2" (M8 - 1.25 x 50), this means the *Nominal size*, or body diameter is 1/2 inch (8mm metric thread diameter), the second number, 16, represents the *threads per inch*, (*distance between threads*). The final number is the body length of the bolt or screw, 2 inches (50mm).

NOTES

- These torque values are to be used for all hardware excluding: locknuts, self-tapping screws, thread forming screws, sheet metal screws and socket head setscrews.
- Recommended seating torque values for locknuts:
 - for prevailing torque locknuts - use 65% of grade 5 torques.
 - for flange whizlock nuts and screws - use 135% of grade 5 torques.
- Unless otherwise noted on assembly drawings, all torque values must meet this specification.

Common Hardware Types

Hex Head Capscrew



Washer



Carriage Bolt



Hex Nut

Wrench & Fastener Size Guide

1/4" Bolt or Nut Wrench—7/16"	5/16" Bolt or Nut Wrench—1/2"	3/8" Bolt or Nut Wrench—9/16"	7/16" Bolt or Nut Wrench (Bolt)—5/8" Wrench (Nut)—11/16"	1/2" Bolt or Nut Wrench—3/4"
M6 Bolt or Nut Wrench—10mm	M8 Bolt or Nut Wrench—13mm	M10 Bolt or Nut Wrench—17mm	M12 Bolt or Nut Wrench—19mm	M14 Bolt or Nut Wrench—22mm

