

VALVE & BULKHEAD ASSEMBLY FOR KETTLES

1. Begin by disassembling the valve and bulkhead assembly. Separate the coupler, steel washer, and both silicone O-rings. This will leave you with only the nipple and locknut to remove from the valve.

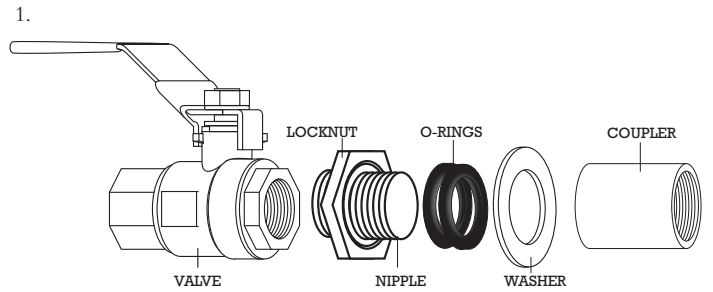

2. Ensure the locknut is threaded on to the nipple as far as it will go. Apply 3 wraps of thread tape to the nipple (on the side where fewer threads are showing), and then thread into the ball valve.

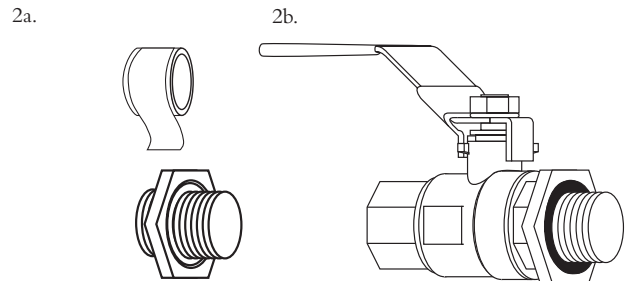

3. Place one O-ring on the nipple and push it all the way into the groove of the locknut, then insert the assembly through the hole in the kettle. The O-ring should be resting on the outside of the kettle.

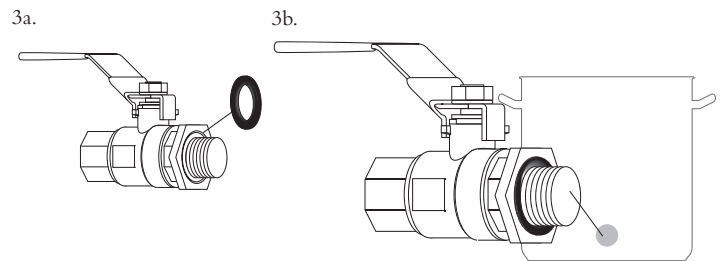

4. On the inside of the kettle, place the other O-ring on the nipple and push it against the inside wall of the kettle.

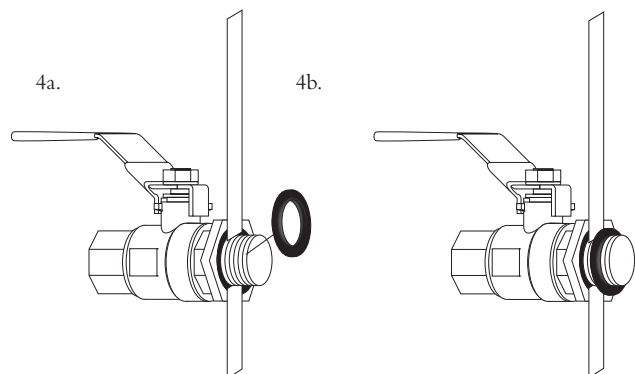

5. Slide the Washer onto the nipple, then thread on the coupler. Hand tighten the coupler until snug, then tighten further by holding the coupler in place and rotating the valve until hand tight.

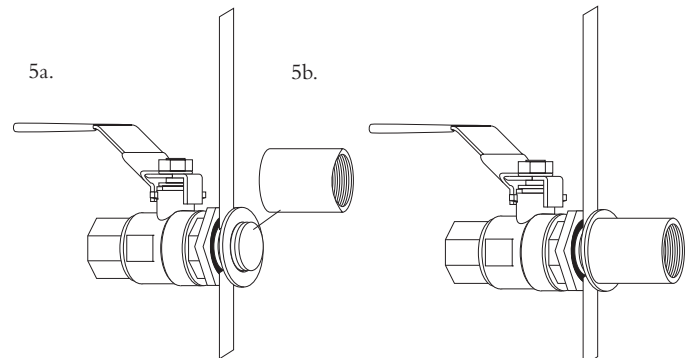

PRO TIP

Fill with water to leak test. If leaking from the O-rings next to the kettle wall, ensure that the O-rings are properly seated and try slightly tightening the locknut. If leaking from the ball valve, remove and apply more thread tape.